

# Servo Drive Series C1200



## Servo Drive C1200

Series C1200 Servo Drives are modular axis controllers, with 32-bit position resolution and an integrated power stage, for linear motors and rotary drives.

The controllers are suitable for simplest, standard, and high-end positioning tasks, across the entire force range of the LinMot product range.



### Connection to Machine Drive

The Series C1200 Servo Drives can be actuated by machine controls from any manufacturer or brand, via digital inputs and outputs, RS232 or RS485 serial interface, CanBus CANopen and DeviceNet interfaces, Profibus DP, or industrial ETHERNET.

### Process and Safety Interfaces

Fast process interfaces for direct processing of sensor signals are available as freely programmable analog and digital inputs, a fast trigger input, and a capture input.

### Logic and Power Supply

The Servo Drives have two separate power supply inputs for the logic and power elements.

In an E-stop and safe stop of the drive, only the power element supply is cut off from the drive. The logic supply and the drive continue to run.

This has the advantage that the drive and linear motor do not need to be reinitialized when the machine is restarted, since all process data, including the current position of the linear motor, are still up to date.

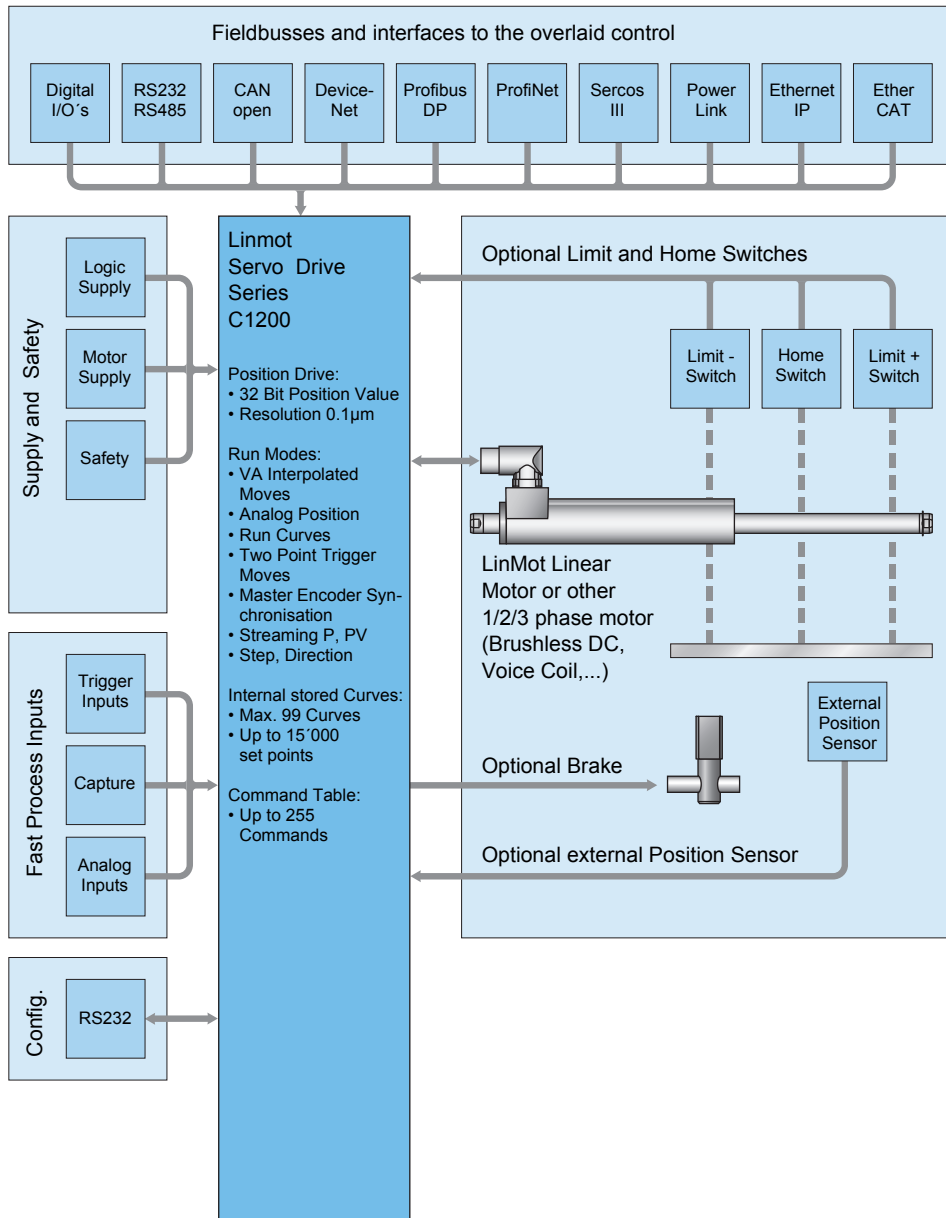

## System Integration

Flexible hardware enables control of any 1/2/3-phase motors. Thus, low-power rotary servomotors, such as brushless DC motors, can be integrated in the same controls concept.

Additionally, the drives can be equipped with optional peripherals, such as reference and end stop switches, high-precision external position sensors, or a mechanical holding brake.

Series C1200 Servo Drives have analog and digital inputs and outputs, serial interfaces, fieldbuses, and ETHERNET connections. The user is therefore not dependent on the selection of the overlaid controller. An appropriate interface is available, with associated protocols, for any PLC or IPC solution.

With flexibility and a compact form factor, LinMot Series C1200 Servo Drives provide a complete solution for a flexible drive concept in single and multiple axis applications, with linear motors and other actuators.

## Technology Functions

Technology functions are functional blocks that provide a complete solution for standard applications and frequently encountered, customer-specific problems. Technology functions can, for example, handle the complete sequence for winding textile yarns or glass fiber cables, or high-precision joining processes with force control can be implemented directly in the drive.

## Motor Interfaces

C1200 Servo Drives provide all necessary interfaces to operate linear or rotary motors with optional external peripherals, such as end position and reference switches, a mechanical brake, or a high-resolution external position sensor.

In special applications, two drives can be synchronized with each other using the synchronization interface in master booster mode.

## Configuration

LinMot Talk user-friendly PC software is available for configuration. In addition to on-line documentation, LinMot Talk provides extensive debugging tools, such as an oscilloscope and an error inspector, for simple and rapid start-up of the Axis.

Fieldbus and ETHERNET drives can also be configured directly by the overlaid control.

## Interpolated Moves

Stroke [mm]

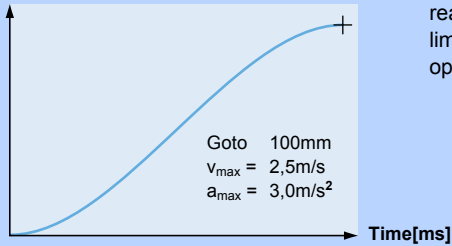

For direct position targets, using absolute or relative positioning, the desired position is reached using acceleration and velocity-limited motion profiles or jerk optimized profiles (jerk limited and Bestehorn). Positioning commands can be invoked via the serial interfaces, CAN-open, DeviceNet, Profibus, Ethernet or a trigger input.

Stroke range:	±100m
Position Resolution:	0.1µm (32Bit)
Velocity Resolution:	1.0µm/s (32Bit)
Velocity Resolution:	10.0µm/s <sup>2</sup> (32Bit)

## Time Curves

Stroke [mm]

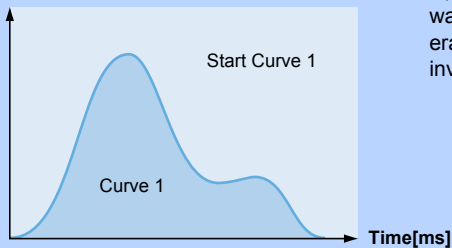

Up to 100 different time curves can be stored Series C1200 drives, with up to 16,000 individual waypoints. The motor can thus travel along time curves of any complexity, such as those generated by CAD programs and stored in the drive (Excel CSV format). The time curves can be invoked via the serial interface, fieldbuses, ETHERNET, or the trigger input.

Stroke range:	±100m
Position Resolution:	0.1µm (32Bit)
Motion profiles:	Max. 100 Time Curves
Curve points:	Max. 16'000 points

## Profiled Moves

Stroke [mm]

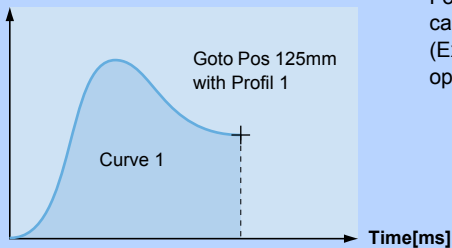

For travel to an absolute position, or shifting by a relative position, any desired motion rules can be stored besides the VA interpolator. They are stored in the drive as motion profiles (Excel CSV format). The positions can be approached, for example, with a sinusoidal motion to optimize power loss, or special reverse optimized motion profiles.

Stroke range:	±100m
Position Resolution:	0.1µm (32Bit)
Motion profiles:	Max. 100 Time Curves
Curve points:	Max. 16'000 points

## Setpoint Streaming

Stroke [mm]

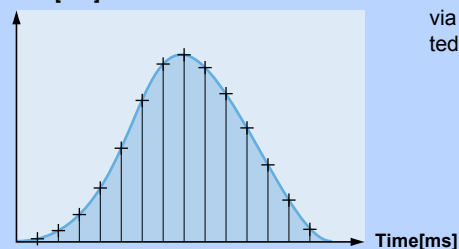

Overlaid NC drives with fieldbus or ETHERNET interfaces communicate with the Servo Drives via "Position Streaming". The position and velocity calculated in the overlaid control is transmitted to the Servo Drive cyclically. The P, PV, or PVT mode is available for this transmission.

Position Resolution:	32 Bit
Velocity Resolution:	32 Bit
Interpolator:	10 kHz
cycle times:	0.4-5ms

## Easy Steps

Input 1	Pos 125mm
Input 2	Pos 250mm
Input 3	Curve 1
Input 4	Pos -30mm
Input 5	Pos +12,5mm
Input 6	Curve 2
Input 7	Pos 2mm
Input 8	Pos -12,5mm

With the Easy Steps function, up to 8 positions or independent travel commands can be stored on the drive, and addressed via 8 digital inputs or fieldbus interfaces/ETHERNET.

Digital inputs: max. 8  
 Interface: X4  
 Scanning rate: 200µsec

## Command Table

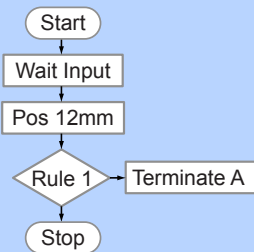

Entire motion sequences with up to 255 individual motion commands can be stored in the Command Table. This is primarily advantageous if complete motion sequences need to be executed very quickly, without dead time from the overlaid drive. In the Command Table, the programmer has access to all motion commands, internal parameters, and digital inputs and outputs.

Commands: max. 255  
 Cycle time: 100µsec

## Analog Position

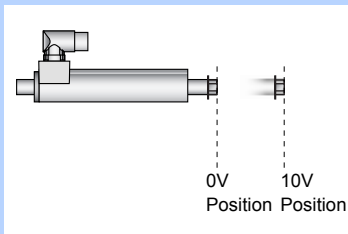

For an analog position target, the linear motor travels to a position proportional to the input voltage. The position is either scanned continuously, or only after a rising edge of the trigger signal. In order to prevent uncontrolled jumps in position, the motor travels to the positions with a programmable maximum acceleration and velocity (VA interpolator).

Inputs: Analog Input X4 or X20  
 Voltage range: 0-10VDC or ±10V  
 Resolution: 12 Bit  
 Scanning rate: >=100µsec (adjustable)

## Easy Steps Parameter Scale

Maximum Force [0...10V => 0...100%]

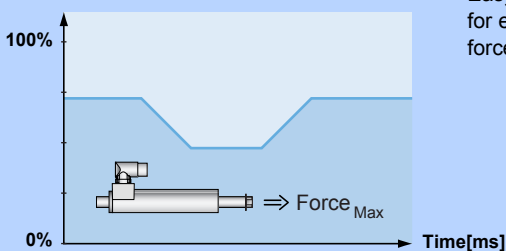

Easy Steps provide the ability to parameterize internal parameters using two analog inputs. If, for example, the maximum motor current is read at an analog input, then the maximum motor force can be provided as analog for freely programmable joining processes.

Inputs: 2 x Analog (X4.4, X4.7)  
 Voltage range: 0-10VDC  
 Resolution: 12 Bit  
 Resolution: 200µsec

## Closed Loop Force Control

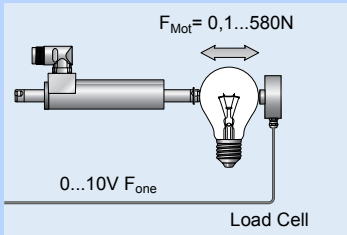

Using the force control technology function, precise joining processes can be implemented reliably and reproducibly with high-precision force control. For force control, the current motor force is measured with a load cell and controlled in the drive. Joining process or quality checks with high requirements for applied force can be implemented.

Analog Input:	0-10V or $\pm 10V$
Resolution:	12 Bit
Min. Force Resolution:	0.1N

## Winding Application

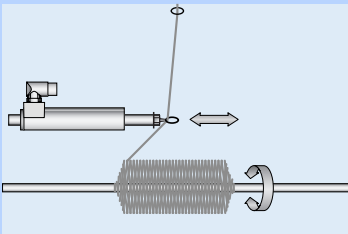

For winding textile yarns, glass fiber optics, or wires, a complete functional block is available that controls the entire sequence of a complete winding process.

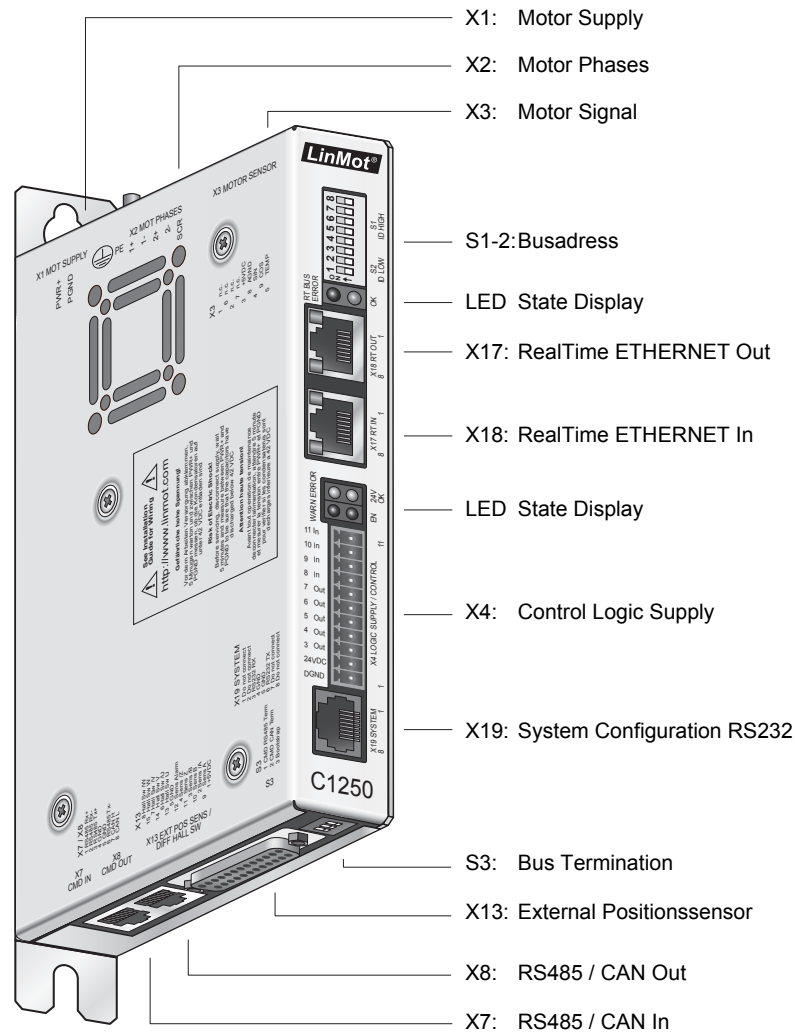

	C1200-GP-XC	C1230-DP-XC	C1250-PL-XC	C1250-EC-XC	C1250-PN-XC	C1250-IP-XC	C1250-SC-XC	C1250-SE-XC
<b>Interfaces</b>								
CANopen	•	•	•	•	•	•	•	•
DeviceNet	•	•	•	•	•	•	•	•
LinRS	•	•	•	•	•	•	•	•
PROFIBUS-DP		•						
POWERLINK			•					
ETHERCAT				•				•
PROFINET					•			
ETHERNET IP						•		
SERCOS III							•	
SERCOS over EtherCAT				•				•
Konfig RS232	•	•	•	•	•	•	•	•

C1200-GP-XC  
 C1230-DP-XC  
 C1250-PL-XC  
 C1250-EC-XC  
 C1250-PN-XC  
 C1250-IP-XC  
 C1250-SC-XC

- ✓ Absolute & Relative Positioning
- ✓ Travel Along Time Curves
- ✓ Positioning using Motion Profiles
- ✓ Internally stored Motion Commands
- ✓ Internally stored Motion Sequences
- ✓ Position Streaming
- ✓ Analog Position Target
- ✓ Analog Parameter Scaling
- ✓ Force Control Technology Function
- ✓ Customer-Specific Functions

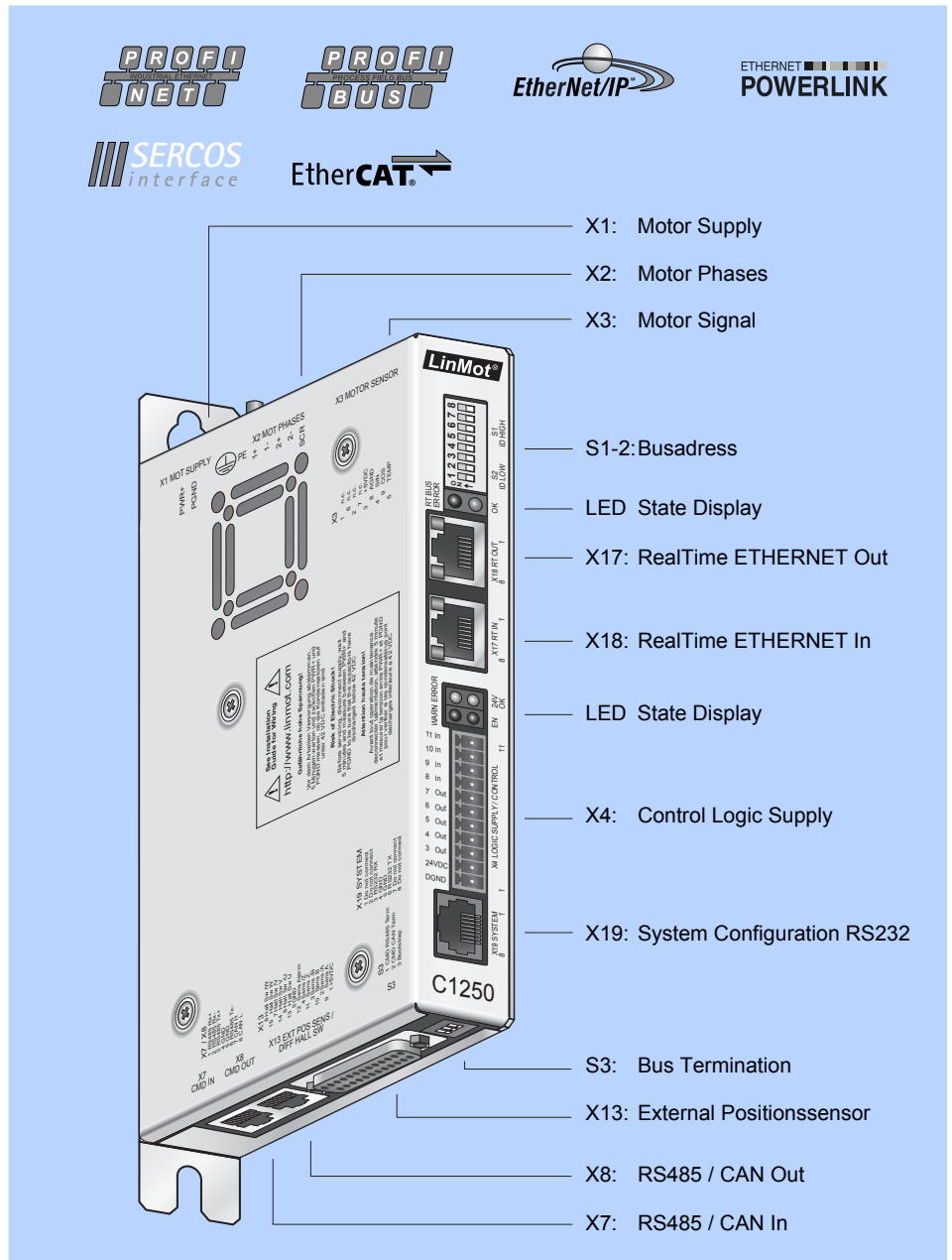

### Industrial ETHERNET

Series C1200 drives allow integration of LinMot linear motors in controls concepts with industrial ETHERNET interfaces. The user can integrate Series C1200 drives regardless of the provider of the overlaid control.

LinMot drives are available with common industrial ETHERNET protocols. Since all ETHERNET drives have the same motion command interface, and the control and status word are identical, software blocks that have been implemented once can be transferred to other drives without a problem.

### Technical Data

Series 1200 Servo Drives support the following industrial ETHERNET protocols:

- Profinet
- Industrial IP
- PowerLink
- EtherCat
- Sercos III

The appropriate drive is available for each protocol.

### Technical Data

Type:	Realtime ETHERNET
Switch/Hub:	Integrated 2-Port Hub/Switch
Transfer rate:	10/100MBit/sec



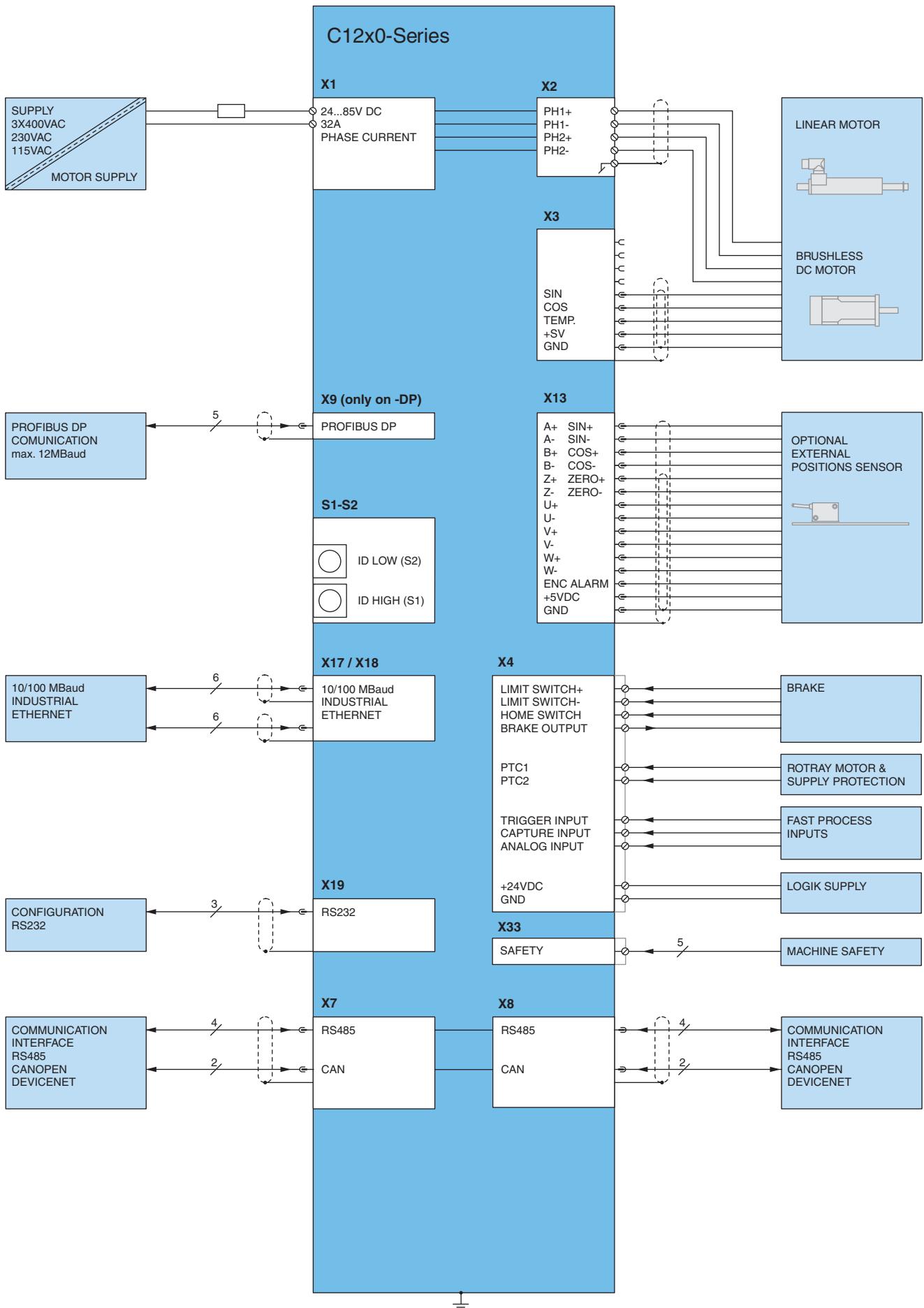

## X1 Motor Supply / Regeneration Resistor



Screw Terminals  
2.5 mm<sup>2</sup> (AWG14)

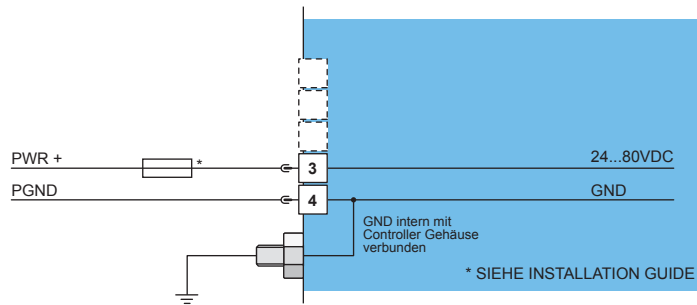

### Motor Supply:

Motor Supply Voltage 24...85VDC.  
Absolute max. Rating 72VDC + 20%



If motor supply voltage is exceeding 90VDC, the controller will go into error state

## X2 Motor Phases

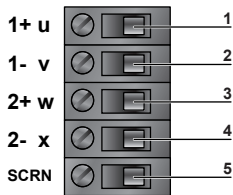

Screw Terminals  
1.5-4mm<sup>2</sup>  
(AWG16-14)

Nr.	Designation	LinMot Linear Motor	Color	3-Phase-Motor
1	PH1+ /U	Motor Phase 1+	red	Motor Phase U
2	PH1- /V	Motor Phase 1-	pink	Motor Phase V
3	PH2+ /W	Motor Phase 2+	blue	Motor Phase W
4	PH2- /	Motor Phase 2-	grey	
5	SCRN	Shield		

## X3 Motor

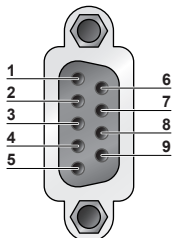

DSUB-9

Nr	LinMot Linear Motor
1	Motor Phase 1+
2	Motor Phase 2+
3	+5VDC
4	Sine
5	Temperature
6	Motor Phase 1-
7	Motor Phase 2-
8	AGND
9	Cosine
Case	Shield

- Use X2 for motor phase wiring if phase current exceeds 5Arms or 7.5Apeak
- Use +5V (X3.3) and AGND (X3.8) only for motor internal Hall Sensor supply (max. 100mA)
- Do NOT connect AGND (X3.8) to ground or earth!

## Motor

## Motor wiring

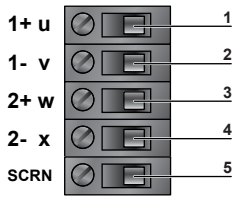

X2: Screw Terminals

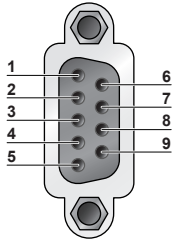

X3: DSUB-9 (f)

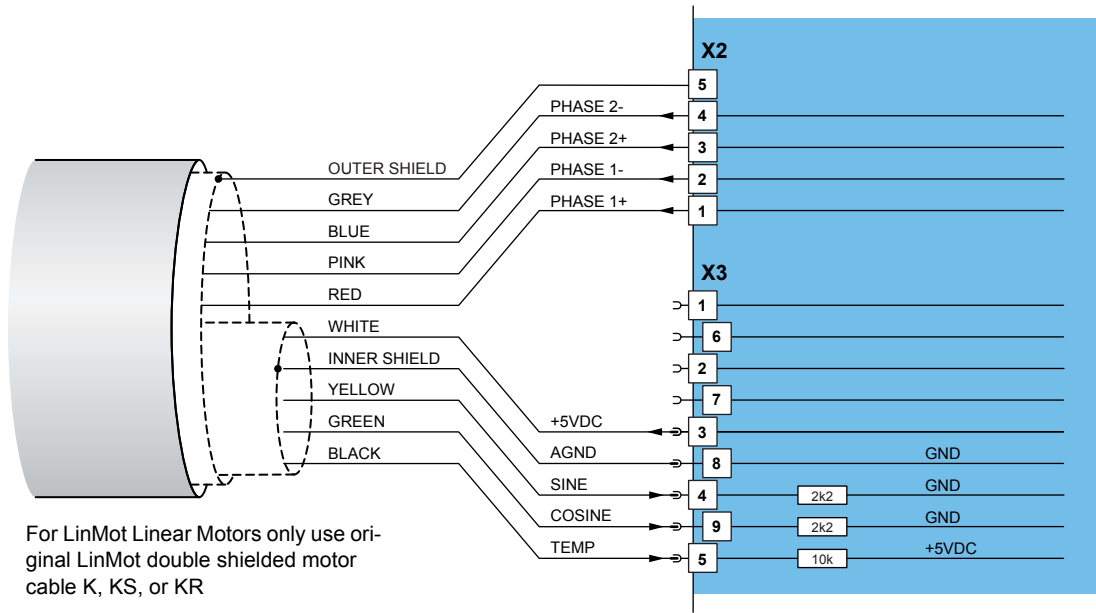

## X4: 11pin

## Control / Supply

- X4. 11 QuickStop, PTC2
- X4. 10 IO, PTC1
- X4. 9 IO, LIM+
- X4. 8 IO, LIM-
- X4. 7 IO, HSW
- X4. 6 IO, TRIG
- X4. 5 IO, CAP
- X4. 4 IO, AN
- X4. 3 IO, /BRK
- X4. 2 +24VDC
- X4. 1 DGND



X14 LOGIC SUPPLY / IO CONNECTION

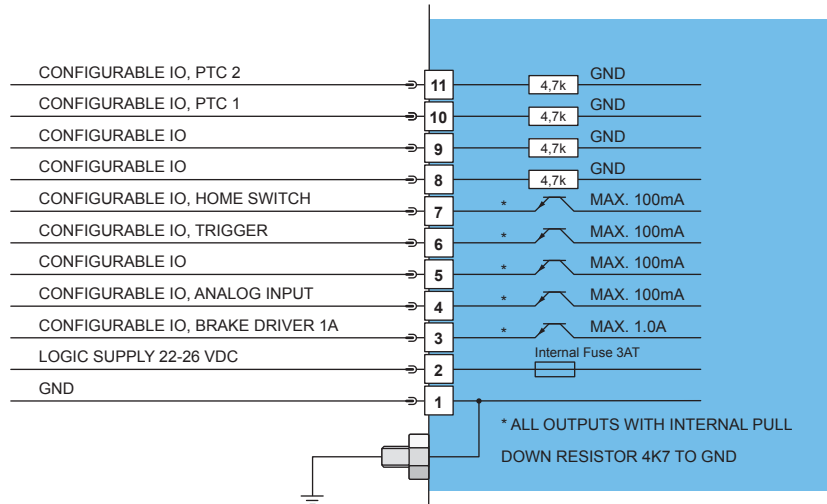

Phoenix MC1,5/12-STF-3,5  
0.25-1.5mm<sup>2</sup> (AWG24-16)

## X7-X8

## RS485/CAN

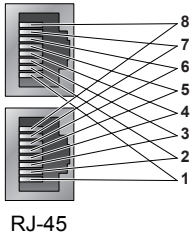

Nr		
1	RS485_Rx+	A
2	RS485_Rx-	B
3	RS485_Tx+	Y
4	GND	
5	GND	
6	RS485_Tx-	Z
7	CAN_H	
8	CAN_L	
Case	Shield	

- X7 internally connected to X8 (1:1 connection)
- Use twisted pair (1-2, 3-6, 4-5, 7-8) cable for wiring.
- The built in CAN and RS485 terminations can be activated by S5.

## X9

## Profibus DP

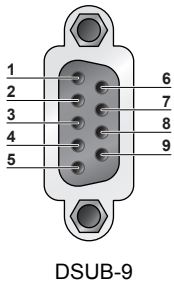

Nr		
1	-	
2	-	
3	RxD/TxD-P	
4	CNTR-P	
5	GND	(galvanically seperated)
6	+5V	(galvanically seperated)
7	-	
8	RxD/TxD-N	
9	-	
Case	Shield	

Max. Baud rate: 12 Mbaud

## S1-2

### Address Selectors / Bus Termination

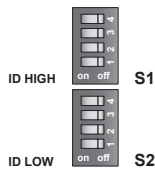

Switch		
S1	Bus ID High (0...F)	HEX-Switches for Bus ID
S2	Bus ID Low(0...F)	address range 0.255

## S3

### Bus Termination



Switch	C1200	
S5	Switch 1: Termination Resistor for RS485 on CMD (120R between pin 1 and 2 on X7/X8) on/off	
	Switch 2: CAN Termination on CMD (120R between pin 7 and 8 on X7/X8) on/off	
	Switch 3: Beostrap	
	Factory settings: all switches "off"	

## X13

### External Position Sensor Commutation

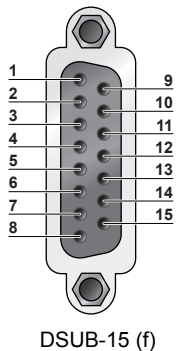

Nr	Description	
1	+5V DC	
9	A+	Encoder
2	A-	Encoder
10	B+	Encoder
3	B-	Encoder
11	Z+	Encoder
4	Z-	Encoder
12	Encoder Alarm	
5	GND	
13	U+	Commutation (Hall Switch)
6	U-	Commutation (Hall Switch)
14	V+	Commutation (Hall Switch)
7	V-	Commutation (Hall Switch)
15	W+	Commutation (Hall Switch)
8	W-	Commutation (Hall Switch)
case	Shield	

Max. Input Frequency:	12MHz (RS422 inkrementell), 40ns edge separation
Sensor Supply Current:	max. 100mA
Position Encoder Inputs:	RS422, Max Input Frequency: 2.5MHz, 5 M counts/s with quadrature decoding, 40ns edge separation
Encoder Simulated Outputs:	RS422, Max Output Frequency: 2.5MHz, 5 M counts/s with quadrature decoding, 200ns edge separation
Differential Hall Switch Inputs:	RS422, Max Input Frequency: <1kHz
Enc. Alarm In:	5V / 1mA
Sensor Supply:	5VDC, max 100mA

## X33: 8pin Safety Relays (only for -1S)

X33. 4/8 Ksr+  
X33. 3/7 Ksr-  
X33. 2/6 Ksr f+  
X33. 1/5 Ksr f-



X33 STO RELAYS

Nr	Bez.	
4 / 8	Ksr +	Safety Relay 1 / 2 Input positive
3 / 7	Ksr -	Safety Relay 1 / 2 Input negative
2 / 6	Ksr f+	Safety Relay 1 / 2 feedback positive
1 / 5	Ksr f-	Safety Relay 1 / 2 feedback negative

## X17-X18 Ethernet RealTime



RJ-45

Nr	Bez.
X17	Specification depends on RT-Bus Type. Please refer to according documentation.
X18	

## X19 RS232 Configuration

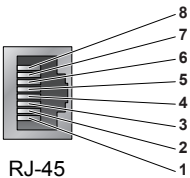

RJ-45

Nr	Bez.
1	Reserved, do not connect
2	Reserved, do not connect
3	RS232 RX
4	GND
5	GND
6	RS232 TX
7	Reserved, do not connect
8	Reserved, do not connect
case	Shield

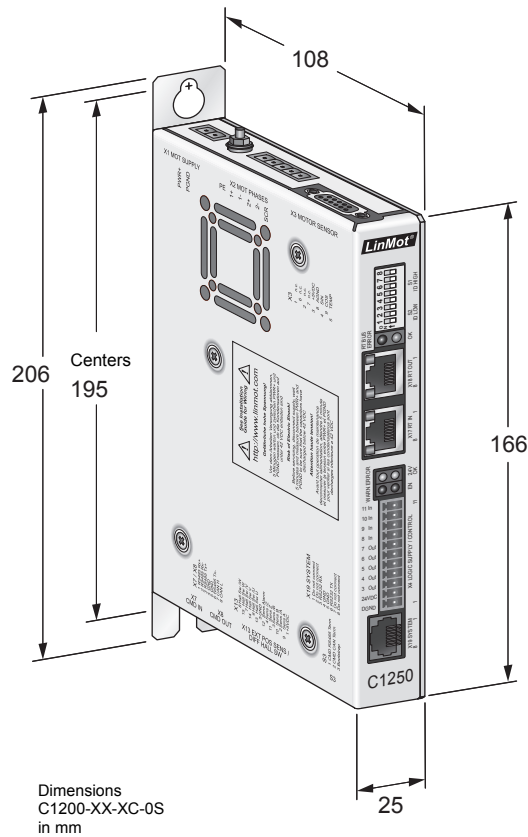

Servo Drives Series		C1200	
Width	mm (in)	25	(1.0)
Height	mm (in)	206	(8.1)
Height without fixings	mm (in)	166	(6.5)
Depth	mm (in)	108	(4.2)
Weight	kg (lb)	1.5	(3.3)
IP Protection class	IP	20	
Storage temperature	°C	-25...40	
Transport temperature	°C	-25...70	
Operating temperature	°C	0...40 at rated date 40...50 with power derating	
Max. case temperature	°C	65	
Max. power dissipation	W	30	
Min. distance between drives	mm (in)	20	(0.8) left/right 50 (2) top/bottom

Item	Description	Part Number
C1200-GP-XC-0S	General Purpose Drive (72V/25A)	0150-1882
C1230-SE-XC-0S	Sercos over EtherCAT Drive(72V/25A)	0150-1897
C1250-EC-XC-0S	EtherCAT Drive (72V/25A)	0150-1884
C1250-PL-XC-0S	PowerLink Drive (72V/25A)	0150-1885
C1250-IP-XC-0S	Ethernet IP Drive (72V/25A)	0150-1886
C1250-PN-XC-0S	Profinet Drive (72V/25A)	0150-1888
C1250-SC-XC-0S	Sercos III Drive (72V/25A)	0150-1887
C1200-GP-XC-1S	General Purpose Drive (72V/25A), STO	0150-2344
C1230-SE-XC-1S	Sercos over EtherCAT Drive(72V/25A), STO	0150-2350
C1250-EC-XC-1S	EtherCAT Drive (72V/25A), STO	0150-2345
C1250-PL-XC-1S	PowerLink Drive (72V/25A), STO	0150-2347
C1250-IP-XC-1S	Ethernet IP Drive (72V/25A), STO	0150-2346
C1250-PN-XC-1S	Profinet Drive (72V/25A), STO	0150-2348
C1250-SC-XC-1S	Sercos III Drive (72V/25A), STO	0150-2349