

LinMot Products	10
Linear Motors	22
Linear Motors High Performance	191
Linear Motors Short Types	199
Linear Motors Stainless Steel IP69K	277
Linear Motors with ATEX	289
Linear Rotary Motors	299
Servo Drives	315
Linear Motors & Servo Drives 3x400VAC	441
MagSpring	467
Linear Guides	479
Accessories	505
Appendix	537
Worldwide Contacts	577

LinMot Products

10



Worldwide Support	11
Industrial Linear Motors	12
Design Element	13
LinMot Fields of Application	14
Innovation & Engineering	16
Production	17
Product Range	18
Examples of use	20

Linear Motors

22

Introduction

22



Mode of Operation	22
Design	22
Variants	24
Sizes	24
Model Description	25
Mounting styles	26
LinMot Sliders	28
Stroke-Force Diagram	30
Performance limits and thermal behavior	30
Stroke-Time Diagram	31
Configuration of Linear Motors	32
Motor Overview	34

Motor Family P01-23x80

39



P01-23x80/10x50	50mm Maximum Stroke, 39N Peak Force	40
P01-23x80/30x90	90mm Maximum Stroke, 44N Peak Force	42
P01-23x80/50x110	110mm Maximum Stroke, 44N Peak Force	44
P01-23x80/80x140	140mm Maximum Stroke, 44N Peak Force	46
P01-23x80/150x210	210mm Maximum Stroke, 44N Peak Force	48
P01-23x80/210x270	270mm Maximum Stroke, 44N Peak Force	50
P01-23x80/280x340	340mm Maximum Stroke, 44N Peak Force	52
P01-23x80/340x400	400mm Maximum Stroke, 44N Peak Force	54
P01-23x80/440x500	500mm Maximum Stroke, 44N Peak Force	56
P01-23x80/620x680	680mm Maximum Stroke, 44N Peak Force	58
P01-23x80/710x770	770mm Maximum Stroke, 44N Peak Force	60

Motor Family P01-23x160

63



P01-23x160/70x70	70mm Maximum Stroke, 49N Peak Force	64
P01-23x160/40x100	100mm Maximum Stroke, 64N Peak Force	66
P01-23x160/0x140	140mm Maximum Stroke, 84N Peak Force	68
P01-23x160/70x210	210mm Maximum Stroke, 84N Peak Force	70
P01-23x160/130x270	270mm Maximum Stroke, 84N Peak Force	72
P01-23x160/200x340	340mm Maximum Stroke, 84N Peak Force	74
P01-23x160/260x400	400mm Maximum Stroke, 84N Peak Force	76
P01-23x160/360x500	500mm Maximum Stroke, 84N Peak Force	78
P01-23x160/540x680	680mm Maximum Stroke, 84N Peak Force	80
P01-23x160/630x770	770mm Maximum Stroke, 84N Peak Force	82

Motor Family P01-37x120

85



P01-37x120/20x100	100mm Maximum Stroke, 163N Peak Force	86
P01-37x120/80x160	160mm Maximum Stroke, 163N Peak Force	88
P01-37x120/180x260	260mm Maximum Stroke, 163N Peak Force	90
P01-37x120/280x360	360mm Maximum Stroke, 163N Peak Force	92
P01-37x120/380x460	460mm Maximum Stroke, 163N Peak Force	94
P01-37x120/480x560	560mm Maximum Stroke, 163N Peak Force	96
P01-37x120/580x660	660mm Maximum Stroke, 163N Peak Force	98
P01-37x120/680x760	760mm Maximum Stroke, 163N Peak Force	100
P01-37x120/780x860	860mm Maximum Stroke, 163N Peak Force	102
P01-37x120/980x1060	1060mm Maximum Stroke, 163N Peak Force	104
P01-37x120/1180x1260	1260mm Maximum Stroke, 163N Peak Force	106
P01-37x120/1380x1460	1460mm Maximum Stroke, 163N Peak Force	108

Motor Family P01-37x240

111



P01-37x240/100x100	100mm Maximum Stroke, 179N Peak Force	112
P01-37x240/40x160	160mm Maximum Stroke, 257N Peak Force	114
P01-37x240/60x260	260mm Maximum Stroke, 308N Peak Force	116
P01-37x240/160x360	360mm Maximum Stroke, 308N Peak Force	118
P01-37x240/260x460	460mm Maximum Stroke, 308N Peak Force	120
P01-37x240/360x560	560mm Maximum Stroke, 308N Peak Force	122
P01-37x240/460x660	660mm Maximum Stroke, 308N Peak Force	124
P01-37x240/560x760	760mm Maximum Stroke, 308N Peak Force	126
P01-37x240/660x860	860mm Maximum Stroke, 308N Peak Force	128
P01-37x240/860x1060	1060mm Maximum Stroke, 308N Peak Force	130
P01-37x240/1060x1260	1260mm Maximum Stroke, 308N Peak Force	132
P01-37x240/1260x1460	1460mm Maximum Stroke, 308N Peak Force	134

Motor Family P01-48x240

137



P01-48x240/30x180	180mm Maximum Stroke, 585N Peak Force	138
P01-48x240/90x240	240mm Maximum Stroke, 585N Peak Force	140
P01-48x240/180x330	330mm Maximum Stroke, 585N Peak Force	142
P01-48x240/300x450	450mm Maximum Stroke, 585N Peak Force	144
P01-48x240/390x540	540mm Maximum Stroke, 585N Peak Force	146
P01-48x240/480x630	630mm Maximum Stroke, 585N Peak Force	148
P01-48x240/600x750	750mm Maximum Stroke, 585N Peak Force	150
P01-48x240/690x840	840mm Maximum Stroke, 585N Peak Force	152
P01-48x240/900x1050	1050mm Maximum Stroke, 585N Peak Force	154
P01-48x240/1080x1230	1230mm Maximum Stroke, 585N Peak Force	156
P01-48x240/1290x1440	1440mm Maximum Stroke, 585N Peak Force	158
P01-48x240/1500x1650	1650mm Maximum Stroke, 585N Peak Force	160
P01-48x240/1680x1830	1830mm Maximum Stroke, 585N Peak Force	162

Motor Family P01-48x360

165



P01-48x360F/60x210	210mm Maximum Stroke, 1024N Peak Force	166
P01-48x360F/180x330	330mm Maximum Stroke, 1024N Peak Force	168
P01-48x360F/270x420	420mm Maximum Stroke, 1024N Peak Force	170
P01-48x360F/360x510	510mm Maximum Stroke, 1024N Peak Force	172
P01-48x360F/480x630	630mm Maximum Stroke, 1024N Peak Force	174
P01-48x360F/570x720	720mm Maximum Stroke, 1024N Peak Force	176
P01-48x360F/780x930	930mm Maximum Stroke, 1024N Peak Force	178
P01-48x360F/960x1110	1110mm Maximum Stroke, 1024N Peak Force	180
P01-48x360F/1170x1320	1320mm Maximum Stroke, 1024N Peak Force	182
P01-48x360F/1380x1530	1530mm Maximum Stroke, 1024N Peak Force	184
P01-48x360F/1560x1710	1710mm Maximum Stroke, 1024N Peak Force	186

Linear Motors High Performance

191



P01-23x80F-HP	780mm Maximum Stroke, 67N Peak Force	192
P01-23x160H-HP	780mm Maximum Stroke, 137N Peak Force	194
P01-37x120F-HP	1480mm Maximum Stroke, 255N Peak Force	196

Linear Motors Short Types

199

Motor Family P02-23Sx80

199



P02-23Sx80/10x50	50mm Maximum Stroke, 39N Peak Force	200
P02-23Sx80/30x90	90mm Maximum Stroke, 44N Peak Force	202
P02-23Sx80/50x110	110mm Maximum Stroke, 44N Peak Force	204
P02-23Sx80/80x140	140mm Maximum Stroke, 44N Peak Force	206
P02-23Sx80/150x210	210mm Maximum Stroke, 44N Peak Force	208
P02-23Sx80/210x270	270mm Maximum Stroke, 44N Peak Force	210
P02-23Sx80/280x340	340mm Maximum Stroke, 44N Peak Force	212
P02-23Sx80/340x400	400mm Maximum Stroke, 44N Peak Force	214
P02-23Sx80/440x500	500mm Maximum Stroke, 44N Peak Force	216
P02-23Sx80/620x680	680mm Maximum Stroke, 44N Peak Force	218
P02-23Sx80/710x770	770mm Maximum Stroke, 44N Peak Force	220

Motor Family P02-23Sx80F-HP

223



P02-23Sx80F/0x60	60mm Maximum Stroke, 67N Peak Force	227
P02-23Sx80F/20x80	80mm Maximum Stroke, 67N Peak Force	228
P02-23Sx80F/40x100	100mm Maximum Stroke, 67N Peak Force	229
P02-23Sx80F/70x130	130mm Maximum Stroke, 67N Peak Force	230
P02-23Sx80F/100x160	160mm Maximum Stroke, 67N Peak Force	231
P02-23Sx80F/140x200	200mm Maximum Stroke, 67N Peak Force	232
P02-23Sx80F/160x220	220mm Maximum Stroke, 67N Peak Force	233
P02-23Sx80F/220x280	280mm Maximum Stroke, 67N Peak Force	234
P02-23Sx80F/290x350	350mm Maximum Stroke, 67N Peak Force	235
P02-23Sx80F/350x410	410mm Maximum Stroke, 67N Peak Force	236
P02-23Sx80F/450x510	510mm Maximum Stroke, 67N Peak Force	237
P02-23Sx80F/630x690	690mm Maximum Stroke, 67N Peak Force	238
P02-23Sx80F/720x780	780mm Maximum Stroke, 67N Peak Force	239

Motor Family P01-37Sx60-HP

241

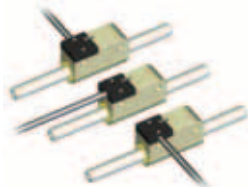

P01-37Sx60/100x120	120mm Maximum Stroke, 122N Peak Force	245
P01-37Sx60/160x180	180mm Maximum Stroke, 122N Peak Force	246
P01-37Sx60/220x240	240mm Maximum Stroke, 122N Peak Force	247
P01-37Sx60/260x280	280mm Maximum Stroke, 122N Peak Force	248
P01-37Sx60/360x380	380mm Maximum Stroke, 122N Peak Force	249
P01-37Sx60/460x480	480mm Maximum Stroke, 122N Peak Force	250
P01-37Sx60/560x580	580mm Maximum Stroke, 122N Peak Force	251
P01-37Sx60/660x680	680mm Maximum Stroke, 122N Peak Force	252
P01-37Sx60/760x780	780mm Maximum Stroke, 122N Peak Force	253
P01-37Sx60/860x880	880mm Maximum Stroke, 122N Peak Force	254
P01-37Sx60/1060x1080	1080mm Maximum Stroke, 122N Peak Force	255
P02-23Sx60/1260x1280	1280mm Maximum Stroke, 122N Peak Force	256
P02-23Sx60/1460x1480	1480mm Maximum Stroke, 122N Peak Force	257

Motor Family P01-37Sx120F-HP

259

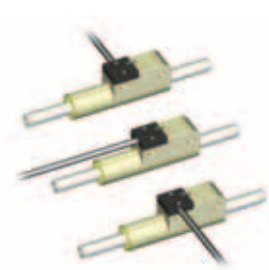

P01-37Sx120F/40x120	40mm Maximum Stroke, 255N Peak Force	263
P01-37Sx120F/100x180	100mm Maximum Stroke, 255N Peak Force	264
P01-37Sx120F/160x240	160mm Maximum Stroke, 255N Peak Force	265
P01-37Sx120F/200x280	200mm Maximum Stroke, 255N Peak Force	266
P01-37Sx120F/300x380	300mm Maximum Stroke, 255N Peak Force	267
P01-37Sx120F/400x480	400mm Maximum Stroke, 255N Peak Force	268
P01-37Sx120F/500x580	500mm Maximum Stroke, 255N Peak Force	269
P01-37Sx120F/600x680	600mm Maximum Stroke, 255N Peak Force	270
P01-37Sx120F/700x780	700mm Maximum Stroke, 255N Peak Force	271
P01-37Sx120F/800x880	800mm Maximum Stroke, 255N Peak Force	272
P01-37Sx120F/1000x1080	1000mm Maximum Stroke, 255N Peak Force	273
P02-37Sx120F/1200x1280	1200mm Maximum Stroke, 255N Peak Force	274
P02-37Sx120F/1400x1480	1400mm Maximum Stroke, 255N Peak Force	275

Linear Motors Stainless Steel IP69K

277



PS01-37x120F-HP-SSC		280
PS01-48x240F-SSC		282
PS01-48x360F-SSC		284

Linear Motors with ATEX

289



PS01-37x120F-HP-ATEX		290
PS01-48x240F-ATEX		292
PS01-48x360F-ATEX		294

Linear Rotary Motors

299



PR01-52x40-R/37x120F-HP-C-80		302
PR01-52x60-R/37x120F-HP-C-100		304
PR01-84x80-C/48x240F-C-100		306
PR01-84x80-C/48x360F-C-100		308

Servo Drives 315

Servo Drive Introduction 316



Introduction	316
Overview	318

Servo Drives Series E100/Series E1001 323



Series E100/E1001-AT	Analog Trigger Drive 1-4 Axis	330
Series E100/E1001-MT	Multi Trigger Drive 1-4 Axis	330
Series E100/E1001-CO	CANOpen Drive 1-4 Axis	332
Series E100/E1001-DN	DeviceNet Drive 1-4 Axis	332
Series E130/E1031-DP	Profibus DP Drive 1-4 Axis	334

Servo Drives E1100 347



Series E1100-RS	RS232/485 Drive	356
Series E1100-DN	DeviceNet Drive	356
Series E1100-CO	CANOpen Drive	356
Series E1130-DP	Profibus DP Drive	358

Servo Drives E1200 371



Series E1200-GP-UC	General Purpose Drive	371
Series E1230-DP-UC	Profibus DP Drive	371
Series E1250-PL-UC	PowerLink Drive	371
Series E1250-EC-UC	EtherCAT Drive	371
Series E1250-PN-UC	Profinet Drive	371
Series E1250-IP-UC	Ethernet IP Drive	371
Series E1250-SC-UC	Sercos III Drive	371

Servo Drives C1200 387



Series C1200-GP-XC	General Purpose Drive	394
Series C1230-DP-XC	Profibus DP Drive	394
Series C1250-PL-XC	PowerLink Drive	394
Series C1250-EC-XC	EtherCAT Drive	394
Series C1250-PN-XC	Profinet Drive	394
Series C1250-IP-XC	Ethernet IP Drive	394
Series C1250-SC-XC	Sercos III Drive	394

Servo Drives B1100 403



Series B1100-PP	Point to Point Drive	408
Series B1100-VF	Force Velocity Drive	410
Series B1100-GP	General Purpose Drive	412

Multi-Axes System B1150 / 8050 423



Series B1150-ML	MC-Link Drive	428
Series B8050-ML	8-Axes Bus Module	430

Linear Motors & Servo Drive 3x400VAC 441

Motor Families P10-70 443



Motor Family PS10-70x80	1770mm Maximum Stroke, 500N Peak Force	447
Motor Family PS10-70x160	1690mm Maximum Stroke, 1000N Peak Force	447
Motor Family PS10-70x240	1610mm Maximum Stroke, 1500N Peak Force	447
Motor Family PS10-70x320	1530mm Maximum Stroke, 2000N Peak Force	447
Motor Family PS10-70x400	1450mm Maximum Stroke, 2500N Peak Force	447

Servo Drives E1400 449



Series E1400-GP-QN	General Purpose Drive	456
Series E1430-DP-QN	Profibus DP Drive	456
Series E1450-PL-QN	PowerLink Drive	456
Series E1450-EC-QN	EtherCAT Drive	456
Series E1450-PN-QN	Profinet Drive	456
Series E1450-IP-QN	Ethernet/IP DP Drive	456
Series E1450-SC-QN	Sercos III Drive	456

MagSpring

467



MagSpring M01-20	50-290mm Stroke and 11-22N Force	470
MagSpring M01-37	50-275mm Stroke and 40-60N Force	472
MagSpring Accessories		474

Linear Guides

479

Linear Guides H01

479



Linear Guides H01-23x86	260mm Maximum Stroke, for P01-23x80	482
Linear Guides H01-23x166	280mm Maximum Stroke, for P01-23x160	484
Linear Guides H01-37x166	280mm Maximum Stroke, for P01-37x120	486
Linear Guides H01-37x286	260mm Maximum Stroke, for SP01-37x240	488
Linear Guides H01-48x250	420mm Maximum Stroke, for P01-48x240	490

Bridge Guides B01

494



Bridge Guides B01-37x166	360mm Maximum Stroke, for P01-37x120	496
Bridge Guides B01-37x286	340mm Maximum Stroke, for P01-37x240	498
Bridge Guides B01-48x250	390mm Maximum Stroke, for P01-48x240	500

Accessories

505



Motor Cables	508
Motor Flanges	518
Slider Mounts	522
Wipers	524
External Position Sensor	526
Switched-Mode Power Supplies	528
Transformer Supplies	532
Regeneration Resistor	534
Connector Cable and Converter	534
Control Box	535

Appendix

537

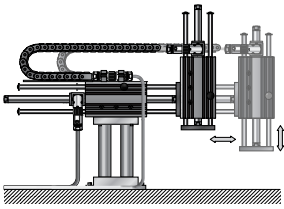

Design Notes	538
Safety Notes	548
AASCII Commands E100/E1001	552
Motion Commands E1100	553
Technology Functions	556
Controlling rotary motors	558
CE-Declaration	561
Product Index	568
Terms and Conditions	576

Worldwide Support

577



America	578
Asia, Far, Middle East & Oceania	578
Europe	579



NTI AG manufactures high-performance linear motors and linear motor systems, focusing on the development, production, and sale of linear direct drives for industrial use.

Our goal is to provide customers with a well-engineered, dedicated linear drive system that can be easily integrated into any industrial control system. Our high level of standardization, delivery from stock, and worldwide sales network ensure immediate availability and local customer support.

The headquarters of NTI AG is in Spreitenbach, near Zurich, in Switzerland. In addition to two production facilities in southern and eastern Switzerland, NTI AG has sales and technical support offices and warehouse (LinMot Inc.) in the USA.

NTI AG

NTI was founded in 1993 as an independent business unit of the internationally active Sulzer Corporation.

In the year 2000, these activities were spun off as the independent company NTI AG.

The goal and purpose of NTI is the development of industrial products, especially direct linear drives for highly dynamic positioning applications.

LinMot

A complete range of industrial linear motors and matching Servo Drives are available under the brand name LinMot.

LinMot products, known for long service life, are used in demanding and highly dynamic positioning applications.

The LinMot product range currently includes over 1000 different drives and linear motors.

MagSpring

NTI produces and sells a second product line, magnetic springs, under the brand name MagSpring.

MagSpring is a new design element, used anywhere that a constant force is required over a long stroke. MagSprings are often used in combination with LinMot linear motors, as counter balances in vertically mounted positioning applications



America

Canada
USA
Brasilia

Europe

Germany
France
England
Switzerland
Holland
Luxembourg
Belgium
Finland
Norway
Sweden
Denmark
Italy
Spain
Portugal
Greece
Turkey
Czech
Repulic
Slovenia
Austria
Hungary

Asia, Far, Middle East & Oceania

Singapore
Thailand
Hongkong
China
Taiwan
Korea
Malaysia
India
Israel
Iran
Syria
Australia
New Zealand

Logistics

LinMot and MagSpring products are standardized products, available worldwide and generally shipped from stock.

Currently, over 1000 different drives and motor combinations are available from stock within 48 hours worldwide.

Warehouse



Worldwide Support

LinMot and MagSpring products are available in over 40 countries, from more than 80 sales facilities.

Our trained sales consultants and applications engineers use modern tools and software to configure the right product to match your application on site.

Industrial Linear Motors LinMot

LinMot linear motors are direct electromagnetic drives. The linear motion is generated without wear, with no intermediary mechanical gearboxes, spindles, or belts. The motor consists of just two parts: the slider and the stator. The slider is made of neodymium magnets, encased in a high-precision stainless steel tube. The stator contains the motor windings, slider bearings, position encoder, and microprocessor circuitry for monitoring motor performance.

LinMot's standard catalog includes different families of motors, with forces up to 2'500N. All models are available with different stroke lengths and features - over 700 different linear motors altogether.



Flexible

LinMot linear motors can be positioned freely along their entire stroke. Travel speed and acceleration can also be precisely defined.

For more complex motions, any number of motion profiles can be stored in the Servo Drive as curves, and the motor can execute the motion at the desired speed.

The motion of the linear motor can also be synchronized with another rotary or linear motion.

Dynamic and precise

Extremely dynamic motions can be achieved with industrial linear motors. Speeds of up to 5,5 m/s and accelerations of well over 500 m/s² provide very short positioning times and high cycle rates.

With the elimination of components afflicted by mechanical play, such as gearboxes or gear racks, linear motors can be positioned as precisely as desired, consistent with the resolution of the measurement system.

Reliable

The internal position sensors measure and monitor the current position of the linear motor, both at rest and in motion. Deviations from desired position are captured immediately and reported to the control system. This guarantees a high level of operational security and reliable error detection.

And, since there are no wearing components, such as gearboxes or spindles for power transmission, even extremely dynamic motions can be achieved with a long operational life.



LinMot Design Element

LinMot industrial linear motors are a design element that offer significant advantages over typical elements such as pneumatic cylinders, servomotors with spindles and belts, or mechanical solutions such as cam, discs or crank designs.

LinMot industrial linear motors are a new design element that enable innovative solutions for completely new functional units, modules, or entire machines that were previously impractical using traditional elements.

The high level of integration (bearings and position sensors are integrated in the motor) and the ability to integrate LinMot systems into a wide range of control systems shorten the design-in time.

Replacement for Pneumatics

Since the form factor of LinMot linear motors is similar to that of pneumatic cylinders, they are often used as replacements for pneumatic cylinders.

This is especially the case when more than two positions are required, if the positions need to be changed via software, or if the dynamics or lifespan of the pneumatic cylinder are not sufficient.

The linear motor also provides the ability to define the speed and acceleration precisely, which makes start-up easier and increases process stability.

Replacement for Servomotors

Linear motors have comparable capabilities and flexibility of rotary servomotors.

The advantages of linear motors are clearly overwhelming, since mechanical accessories such as couplings, gearboxes, belts, spindles, and the extensive design work that they require, can be completely eliminated.

The design-in time and logistical burden are significantly reduced by the elimination of this array of mechanical components.

Replacement for Cam Discs

Mechanical cams allow extremely dynamic motions, but leave much to be desired when it comes to flexibility. Motion profiles can be changed only by extensive mechanical rework.

The very high dynamic capabilities of industrial linear motors, plus the ability to adapt motion profiles in software, have led to the replacement of more and more mechanical cams with LinMot linear motors.

LinMot Fields of Application

LinMot linear motors and Servo Drives are built for use in harsh, demanding industrial environments. Their exceptional technical properties, low-maintenance operation, and extremely long life set them apart.

The enclosed design, with all motor components encased in a solid steel tube, as well as integrated magnetic field position sensors, allow reliable operation even in dirty or wet environments (protection class up to IP69K).

Within the wide Product range, electrical products for complex Servo application and simple pneumatic replacement are available.

All of these properties make linear motors the ideal solution for linear motions in packaging machines, material handling, textile machines, medical equipment, custom machines, and many other applications.



Packaging Machines

- Cartoners
- Tubular bag machines
- Blister packaging
- Wrappers
- Stick packaging machines
- Banderoling machines

- Metering systems
- Weighing systems
- Portioning systems

- Closing machines
- Sealing stations

- Pick & place robots
- Palletizing systems

Assembly & Handling Systems

- Feeders
- Transfer systems
- Pick & place modules
- Palletizing units
- Stacking units
- XY tables
- Precision pressing
- Sorting systems
- Automatic screwdrivers
- Metering units
- Gluing stations
- Quality assurance
- Test fixtures
- Camera positioning
- Lighting positioning

Printing & Labeling

- Screen print machines
- Offset print machines
- Tube printing machines
- Label printing machines
- Laser marking systems
- Film printing machines
- Flexo printing machines
- Inkjet printing
- Embossing machines

- Print head positioning
- Quality control

- Automatic printers
- Automatic labellers
- Label positioning



LinMot linear drives are used in a wide range of applications as solution for various drive tasks that were previously addressed with pneumatic cylinders, servomotors, or mechanical cam drives:

- Feeding
- Insertion
- Escapement
- Folding
- Sealing
- Loading
- Stacking
- Palletizing
- Unloading
- Diverting
- Assembly
- Press joining
- Pressing
- Punching
- Vibration
- Mixing
- Separation
- Lime application
- Flying carpet
- Synchronous insertion
- Fill level metering
- Blister filling
- Pallet filling
- Bottle and tube filling
- Sealer control
- Printer's mark alignment
- Pad printing
- Doctor blade controls
- Label positioning
- Label application
- Camera positioning
- Lighting positioning
- ...

Semiconductor, Electronics, CD/DVD

Front-end machines
Back-end machines

Wafer handling
Die bonding
Wire bonding
Semiconductor handling
Semiconductor testing
Semiconductor packaging

Automatic population
Flying Probe Tester
Blank separators

CD/DVD production systems
CD/DVD packaging machines

Laboratory Automation

Life science research
Chemical analysis
Pharma screening
Laboratory automation

Liquid handling platforms
Flexible robotic workstations

Sample handlers
Plate handlers
Flask dispensers
Storage handling
De-cappers & re-cappers
XYZ robots

Bioreactors, soft mixers

...much more

Specialty machines
Machine tools
Auto industry
Process industry
Textile industry
Tobacco industry
Medical technology
Pharma & cosmetics
Foodstuffs processing

Plastics machinery
Injection molding machines
Stamping machines
Coating systems
Grinders
Motor test stands

Innovation & Engineering

Continuous advancement and active exchange between our sales consultants, engineers, sales partners, and customer's management, and engineering, allow us to provide customer-specific products and marketable new products quickly and at a reasonable cost.

Thanks to standardized, modular construction, LinMot can realize our OEM customer's application specific variables even in moderate quantities.

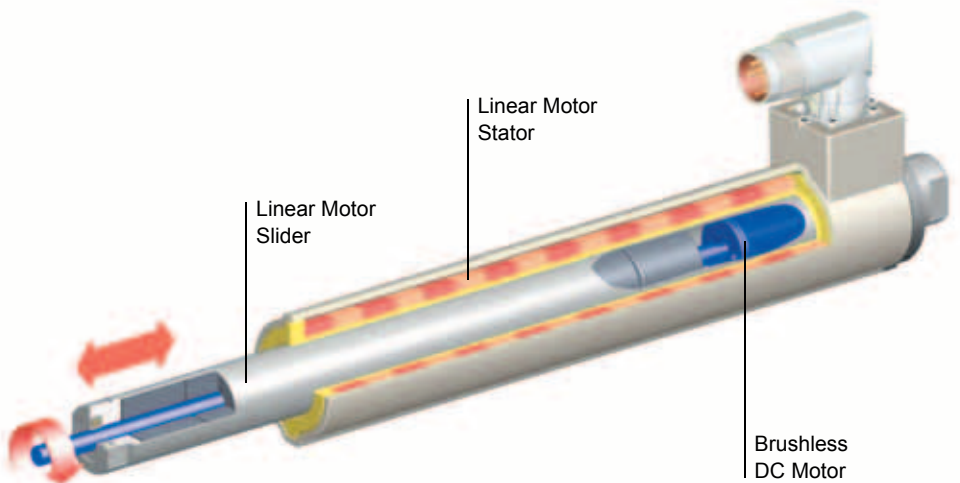

An example of a customer-specific solution: compact linear/rotary unit with linear and rotary motions. The rotary servomotor is directly integrated in the slider of the linear motor.

Expertise

As a provider of industrial linear motors, Servo Drives, and mechanical components, we have acquired a great deal of expertise over the years in the areas of linear direct drives, servo technology, field-busses, and electromechanical systems and modules.

We are happy to offer our expertise in working out innovative solutions and new drive concepts for your application.

Innovation

LinMot and MagSpring products are developed as innovative solutions for drive applications in the industrial environment.

NTI AG works to further advance these innovations, and to bring to market additional solutions and products in the field of linear drive technology.

For this reason, the product range will continue to be expanded with interesting new developments.

You can find the latest information on our new products on the internet at www.LinMot.com.

Customer-Specific Solutions

As the world's leading manufacturer of industrial linear motors, NTI AG applies our acquired expertise and innovation to the implementation of customer-specific solutions as well.

Our application development engineers are available to help our customers find optimal solutions to specific drive problems.

Our customers can rely on our years of production experience for the implementation and manufacture of customer-specific drive solutions.

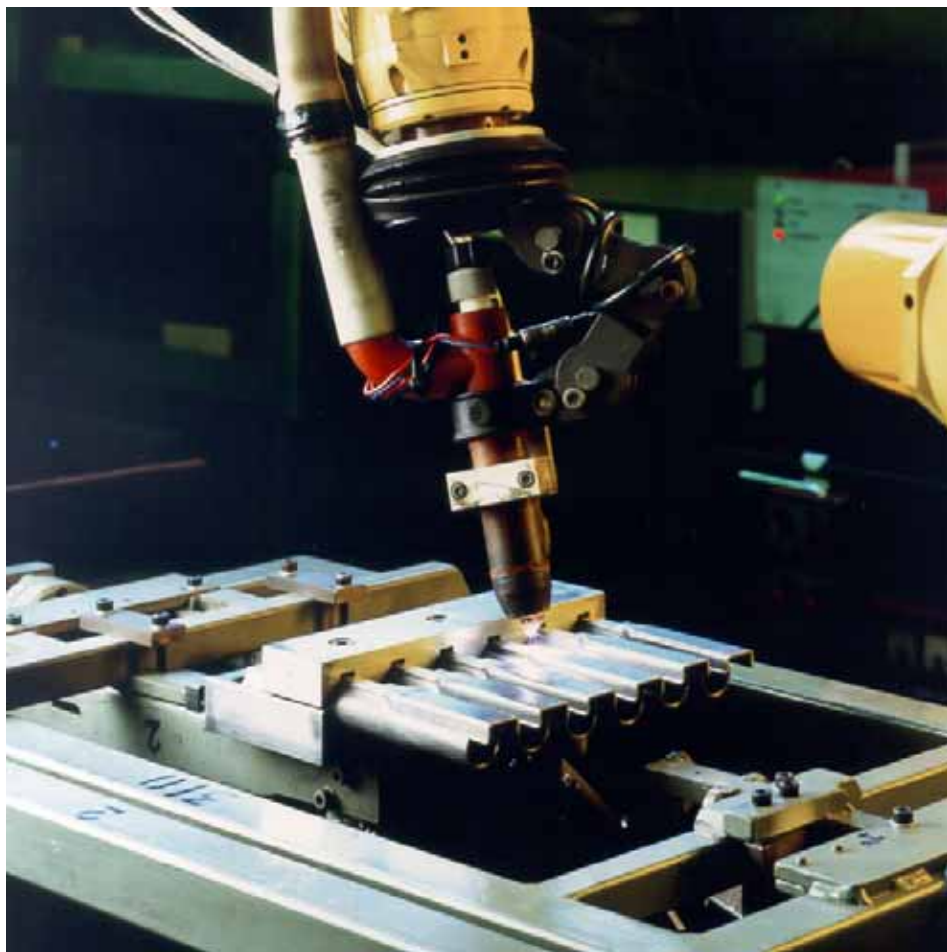

Production

One of the chief corporate goals of NTI AG is to provide our business partners with high-value products at attractive prices.

In order to reach this goal, LinMot and MagSpring products are manufactured on modern production systems. High standardization and automated manufacture ensure reliable, reproducible series production at the highest level of quality.



Worldwide Availability

Since LinMot and MagSpring products are manufactured as standard design elements, worldwide support and rapid availability play a central role.

NTI works with the leading suppliers of world wide express delivery services.

More than 1000 LinMot and MagSpring products are available from stock, and can be delivered around the world with a 48-hour express service if needed.

Automated Production

The standardized LinMot and MagSpring products are manufactured on largely internally designed production systems. This guarantees rapid availability of the products, even in large quantities, and with maximum flexibility for customer-specific adaptations.

Automatic production also guarantees consistent uniformity and high quality.

Quality

Quality control starts with incoming goods inspection, and continues in production for each individual production step, and final testing before shipment. All linear motors are subjected to a 24-hour burn-in prior to shipment.

For long-term quality assurance, LinMot and MagSpring products are labelled with a unique serial number, on the label and in the electronic nameplate in the stator and Servo Drive.

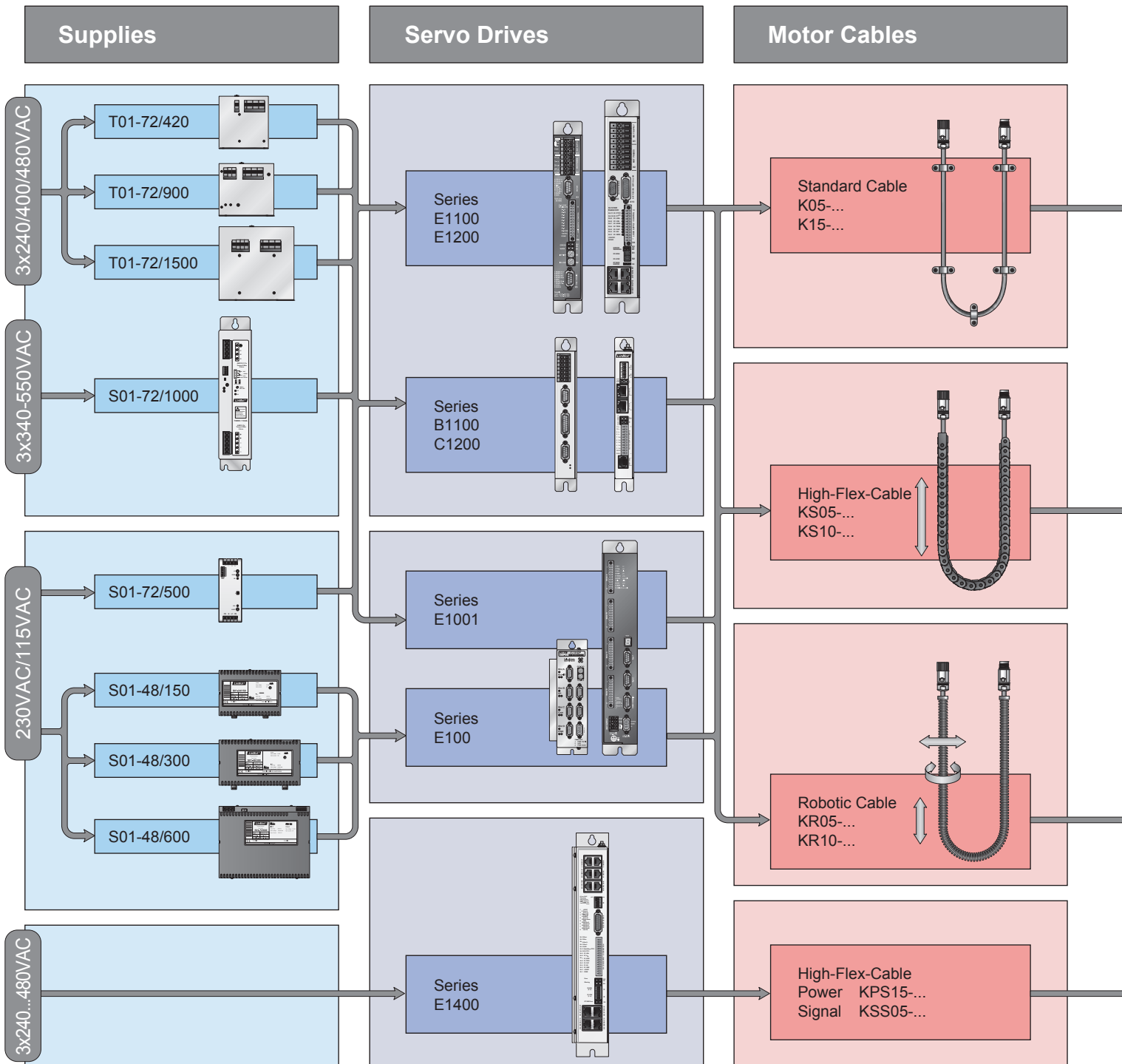

Power Supply Modules

Power supply modules provide the power needed by the motor, and ensure secure operation in compliance with current EMC standards.

Central power supply modules also reduce energy usage in dynamic multi-axis applications, by exchanging energy during alternating acceleration and deceleration of the drive axes.

Power supply modules are available at various power ratings, in 1 or 3-phase versions.

Servo Drive

LinMot Servo Drives are compact positioning drives with integrated power units for dynamic and precise control of linear motors or brushless servomotors.

A wide range of analog, digital, and serial interfaces and various fieldbus interfaces allow integration into any controls concept.

LinMot Servo Drives are available as flexible single-axis or compact multi-axis devices.

Motor Cable

Special double-shielded cables are available for secure and fault-free linear motor operation.

Motor cables are available in various gauges and configurations. Depending on the application and mounting location, standard, high-flex (cable only, without cable track), or robotic cables are available.

The length of the motor cable can be up to 50 m between the linear motor and the drive.

Linear Motors

Mounting Flanges

Linear Guides

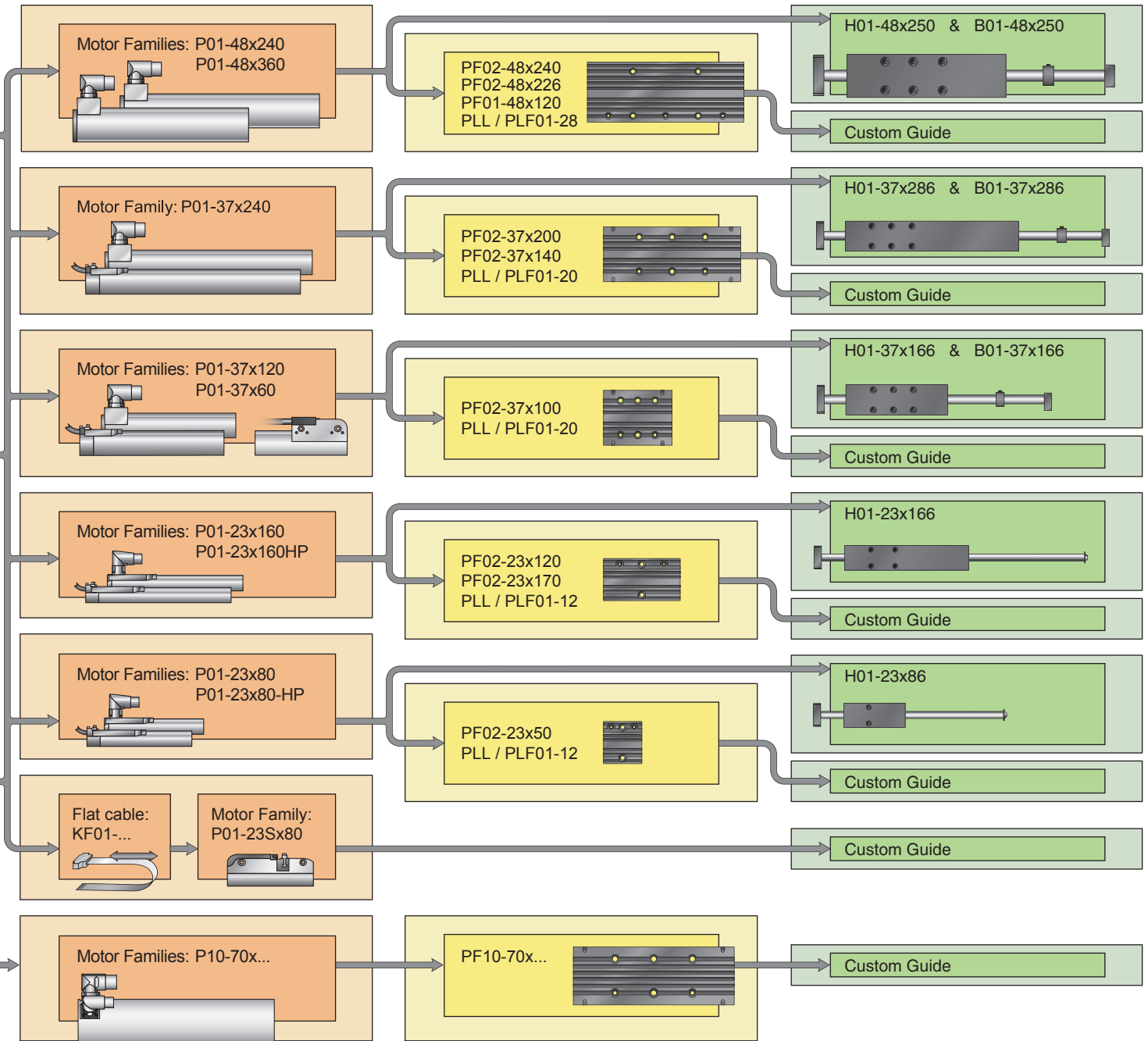

Linear Motors

LinMot linear motors are compact design elements for dynamic positioning applications, with integrated position measurement, temperature monitoring, and electronic nameplates.

The linear motor consists of a magnetic slider and a stator, which is connected to the Servo Drive via the motor cable.

LinMot linear motors are available in 18 different families, with a cable outlet or plug connection, with forces from 33 N to 2500 N.

Mounting Flanges

Matching mounting hardware is available for mounting each size of linear motor.

The stator is mounted using a clamp flange. This ensures easy mounting and optimal cooling of the motor. If needed, the flange can be equipped with a fan.

Complete mounting kits with fixed and floating bearings are available for mounting the slider.

Linear Guides

The load mounted on the motor should be guided with linear guides.

For short stroke motions, LinMot carries its own linear guides. They are available with ball bushings or plain bearings, and can be retrofitted with additional options, such as load balancers or mechanical brakes.

For long stroke motions and special applications, any linear bearing can be used. LinMot has an extensive range of mounting accessories.

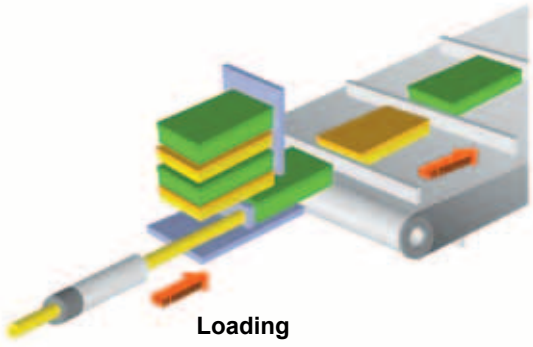

Loading

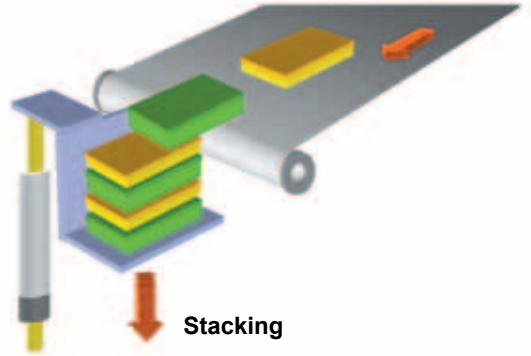

Stacking

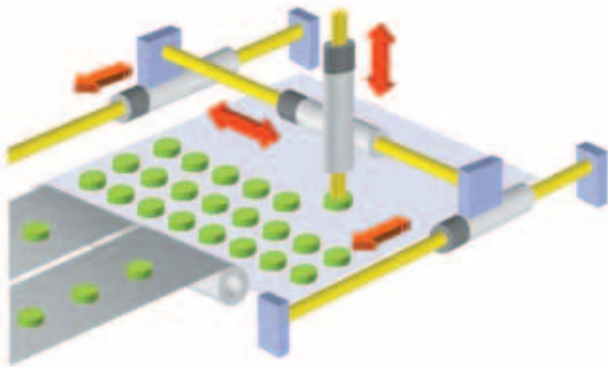

Palletizing

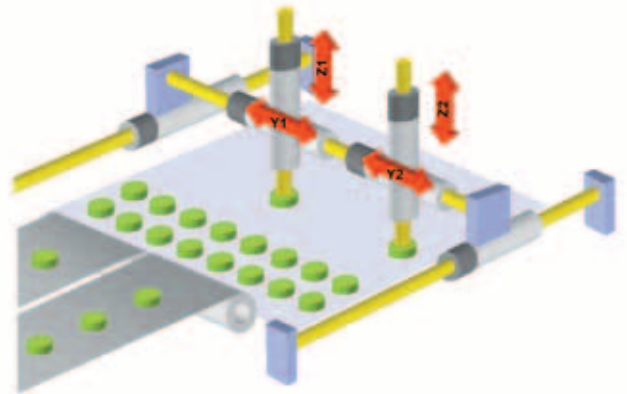

Palletizing

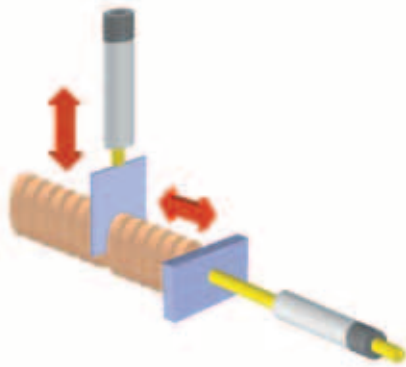

Cutting

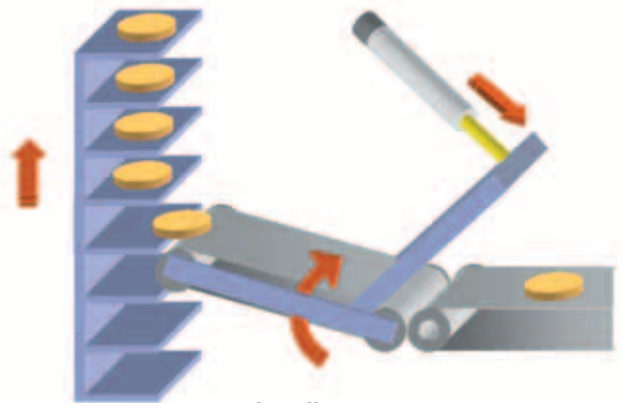

Loading

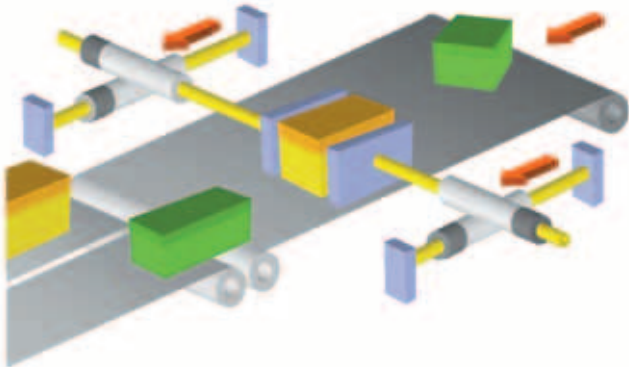

Alignment

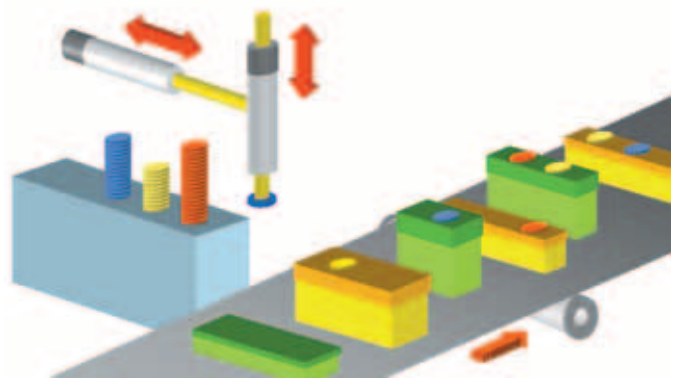

Labeling



2-Axis Assembly Module

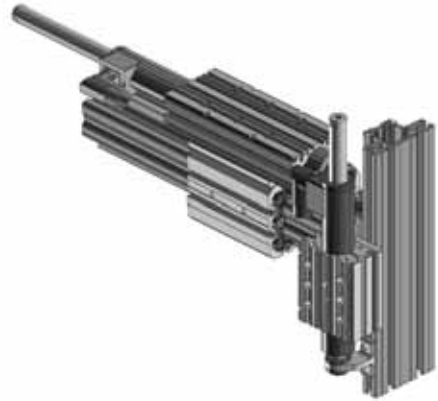

2-Axis Pick and Place



Hexapod Parallel Kinematics

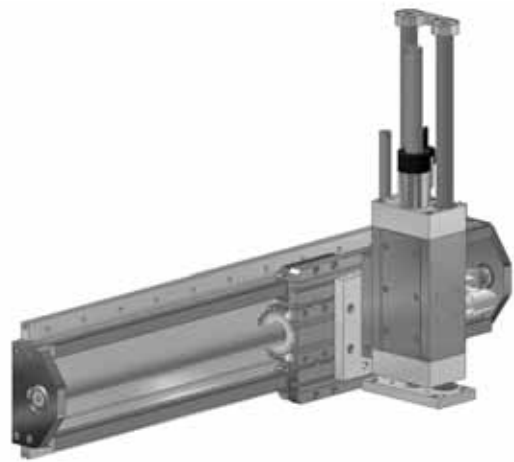

Installation module



4-Axis Palletizing Robot

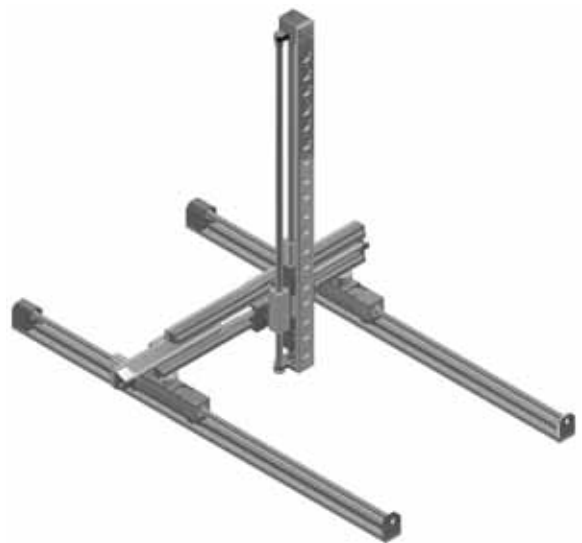

4-Axis Load and Unload Station

Linear Motors

LinMot P is a family of linear direct drives for highly dynamic motions.

The motor is made up of just two parts: the slider and the stator. The two parts are not connected by brushes or cables. The linear motion is generated directly by electromagnetic forces, without the wear associated with mechanical gearboxes, belts, or levers. Extremely dynamic motion sequences can be obtained with a long lifespan.

Cylindrical design and integrated bearings and position sensing make LinMot linear motors a compact design element.

Typical applications range from rapid positioning, lifting, and pushing motions, to synchronous pick and place applications, to complex palletizing gantry robots.

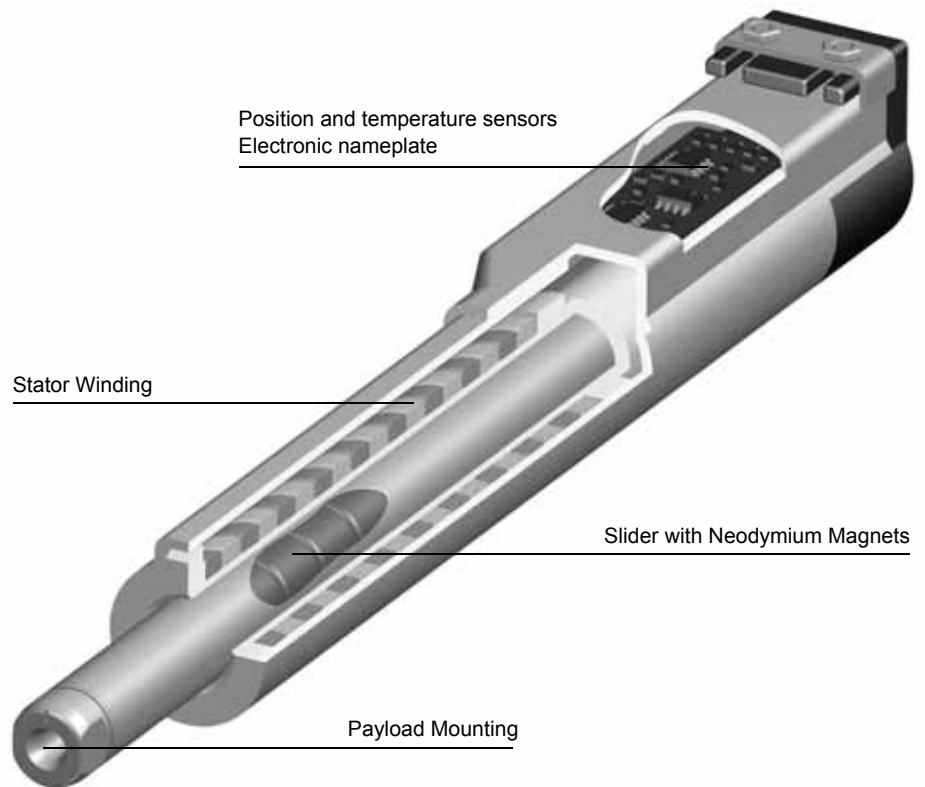

Mode of Operation

LinMot linear motors are permanently actuated synchronous servo motors, with integrated position measurement and overload protection. Permanent magnets in the slider (like a rotor) and windings in the stator are used to generate forces, like in a brushless rotary motor. The configuration and different arrangement of the magnets generate the linear motion directly, using electromagnetic force, without mechanical elements that are subject to wear.

Design

The windings, position sensors, temperature monitoring, and bearings are all located in the stator. It consists of a solid metal cylinder in which the motor components are cast, so that they are optimally protected from damage and contamination (IP67). The stators are available in two versions, with direct cable exit or a rotating angle

connector. The slider consists of a stainless steel tube in which the drive magnets are mounted. During operation, the slider is guided by the plain bearing integrated in the stator. There is no electrical or mechanical connection between the slider and the stator.

Flexibility

Freely positionable

with no mechanical end play along the entire stroke

Adjustable speed

within a range of 0.001 - 5.5m/s

Adjustable acceleration

for highly dynamic or slower moves.

Synchronization & motion profiling

for complicated motions and replacement of cam discs

Adjustable force

for totally programmable press and joining operations

Dynamics

Highly dynamic

Acceleration values of well over 500 m/s² and travel speeds over 5.5 m/s allow cyclical motion sequences of several Hertz

Controlled dynamics

For handling applications with sensitive products, such as transporting wafers in semiconductor production, very gentle, smooth motions with suitable accelerations can be obtained.

Process Stability

Process stability

Since not only the end positions, but also speed and acceleration are controlled and monitored, motions that are programmed once are carried out the same way over the entire life of the machine.



Integrated Position Measurement

LinMot linear motors and LinMot Servo Drives form a closed-loop drive system. The position is detected in the motor by non-contact magnetic field sensors. These provide the Servo Drive with a sine/cosine signal, so that the current position is always available to the drive with no lag. In contrast to incremental position measurement, steps cannot be lost. Since

position detection is done purely magnetically, with no optical sensors, and with the magnetic sensors being cast into the stator, LinMot linear motors can be used even in damp or dirty environments.

Freely Positionable

LinMot linear motors can be freely positioned. With absolute or relative movement commands, they can move to any desired position in the stroke range. Since the LinMot linear drive is a closed-loop system, not only the end positions are monitored, but also deviations in position during travel. This allows, among other things, precise specification of travel speeds, acceleration and braking ramps, and travel through curved paths. For synchronous machines, the linear motor can be synchronized to the main shaft. By replacing mechanical cam discs with LinMot linear motors, for example, great variations can be achieved, with format changeovers at the push of a button.

Overload Protection

There are no mechanical components for force transfer that could be damaged in a crash or stall condition in a linear motor. Complex, expensive designs to protect gearboxes, gears, and shafts are thus eliminated. If the linear motor stalls, it acts like a pneumatic cylinder and tries to reach the target position with maximum force. The following error monitor in the drive can, however, immediately recognize a stall condition. Temperature sensors integrated in the stator prevent the drive from overloading in any case.

Lifespan

Long Lifespan

Since the linear motion is generated purely magnetically, and no mechanical force transmission takes place, even extremely dynamic applications can be implemented with a long lifespan.

Reliability

Robust, even in exceptional situations

Since forces are generated purely magnetically, no mechanical components, such as gearboxes, belts, or spindles, can be damaged in case of a crash.

High Reliability

Since LinMot linear motors have no wear parts and a long lifespan, due to their operating principle, a high level of reliability is guaranteed, even in fast-moving machines.

Environmental Conditions

IP69K

LinMot linear motors are cast under vacuum, are splash-proof, and have protection class up to IP69K.

Clean Room Compatible

The Fraunhofer Institute has confirmed clean room compatibility (Certification FM9805-3475 per US Fed. Standard 209E).

Use in dirty environments

The magnetic measurement system and cast body style allow secure operation even in damp or dirty environments.

Variants

In order to provide the right solution for every application, the motors are available in various versions:

The stators are available with a rotating IP67 angle connector, or with cable exit. This allows simple installation, even in difficult spaces.

Since no gearboxes are used with linear direct drives, various winding options allow optimal adjustment of force and speed for a given application.

Sizes

LinMot linear motors are available in various sizes with different strokes and force ranges. The wide range of product variations means that the right linear motor can be found for any application.



Connector Type Motors



Cable Type Motors

Simple Installation

The connection between the motor and the Servo Drive requires only a single cable. Since all motors have a connector either directly on the motor or at the end of the motor cable, installation is as simple as you might think. Motor cables are available from stock in various lengths, in dif-

ferent versions. The standard cable is suitable for stationary applications. For applications with moving cables and stators, high-flex motor cables are available for use with cable tracks, and robotic cables are available for applications with cable torsion.

Connector Type Motors

The connector is protection class IP67. The angle connector can be rotated about its own axis, so that the motor cable can be led away from the motor in any direction.



For applications with moving stators, motors with connectors have an advantage; a cable-chain compatible cable can be plugged directly into the motor and run through the cable track.

Cable Type Motors

Motors with cable exit are particularly well suited to difficult installation locations, where there is no room for the connector.

Since the cable end is cast directly into the motor, these motors can be used in applications with difficult environmental conditions.



For motors with cable exits, the cable attached to the motor must be mounted securely.

Short Motor

A shorter version of the smallest linear motor is available under the designation P02-23Sx80. Instead of a rotating IP67 connector, the short motor has a ZIF line plug for a flexible flat ribbon cable.

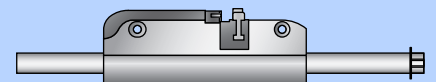

The short motor was developed for laboratory automation applications. Due to the connector style and the flat ribbon cable, this motor is not suitable for use in dirty or damp environments.

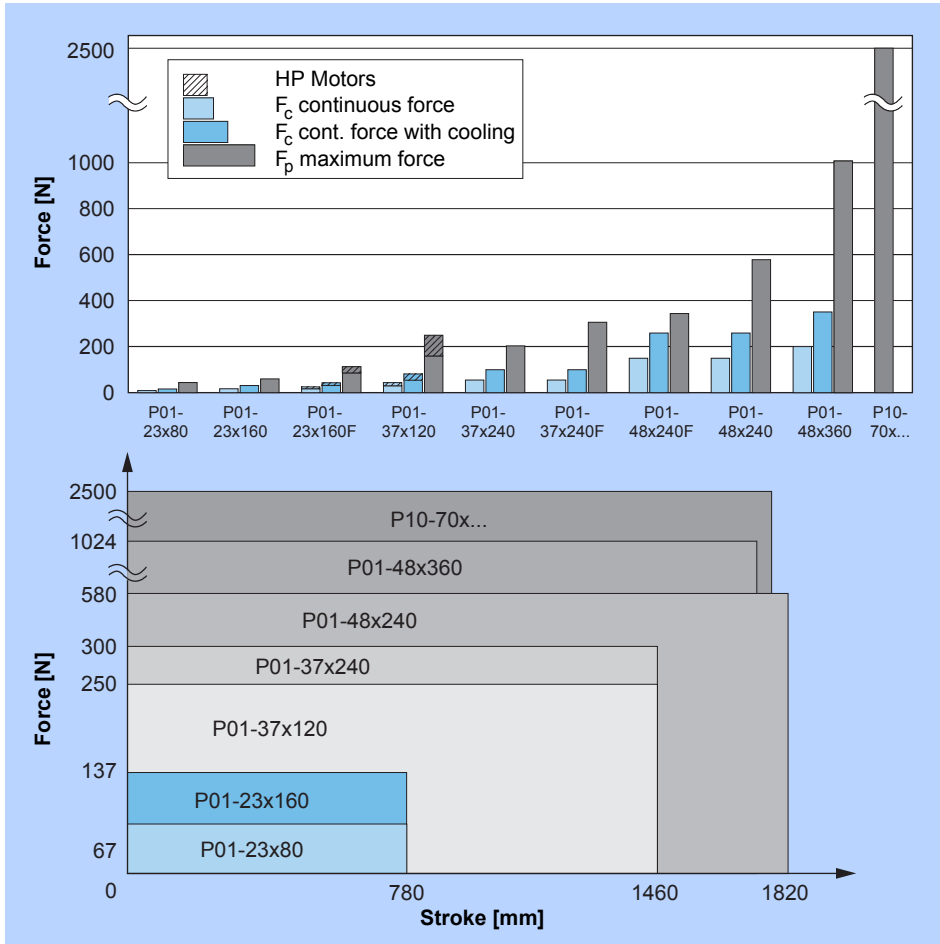

Model Description

The most important motor characteristics are encoded in the model description:

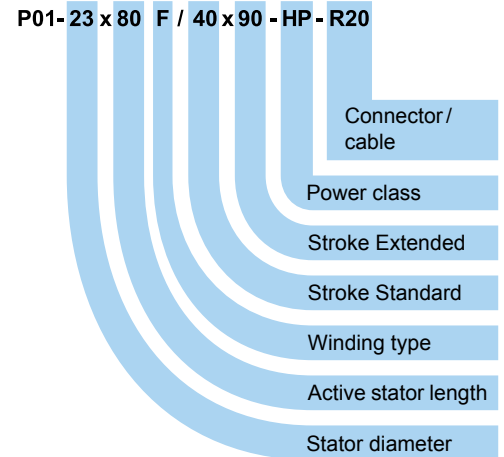

Electronic Nameplate

LinMot linear motors have an electronic nameplate in the stator, on which all specific motor data, as well as production and article information, is stored. The electronic nameplate guarantees simple and error-free configuration during startup. Using the stored production data, the servo

drive compensates for even the smallest production tolerances, in order to provide the best possible accuracy and optimal control behavior, even under difficult conditions.



CAD Data

2D and 3D CAD data are available for linear motors and accessories at www.LinMot.com.

Winding Types

Certain stators are available in two versions, with standard windings or a special winding for higher top speeds. These have advantages primarily in long-stroke applications, which may require increased maximum speed. Stators with the special windings are indicated with an F or H in the description. Mechanical dimensions are identical to those of stators with standard windings.

High Performance Motors

The new High Performance linear motors have significantly more power than standard motors of the same size and dimensions.

The increased power comes from optimization of the motor windings, the magnet circuit, and heat dissipation. Also, further advances in magnet materials have been made in recent years.

With High Performance motors, the user has nearly double the available power.

Motor Cables

Stators with cable exit, in size P01-23, are provided with standard cable lengths of 20cm with IP67 plugs, 100 cm with D-plugs.

Stators with cable exit, in size P01-37, are provided with standard cable lengths of 20cm with IP67 plugs, 150 cm with P-plugs.

Motor cables of up to 50m can be used between the linear motor and the Servo Drive.

LinMot offers a wide range of extension cables in various versions.

(Motor Cables see page 508).

"Moving Slider" Applications

In a "moving slider" installation, the stator is fixed and the slider is the moving part.

The load, borne by a linear guide, is attached directly to the end of the slider. In order to compensate for misalignment, spherical axial bearings consisting of rounded washers and ball sockets may be used to connect to the load.

The "moving slider" installation has advantages of short-stroke and very dynamic motions, since the moving mass is small and the motor cable does not move.

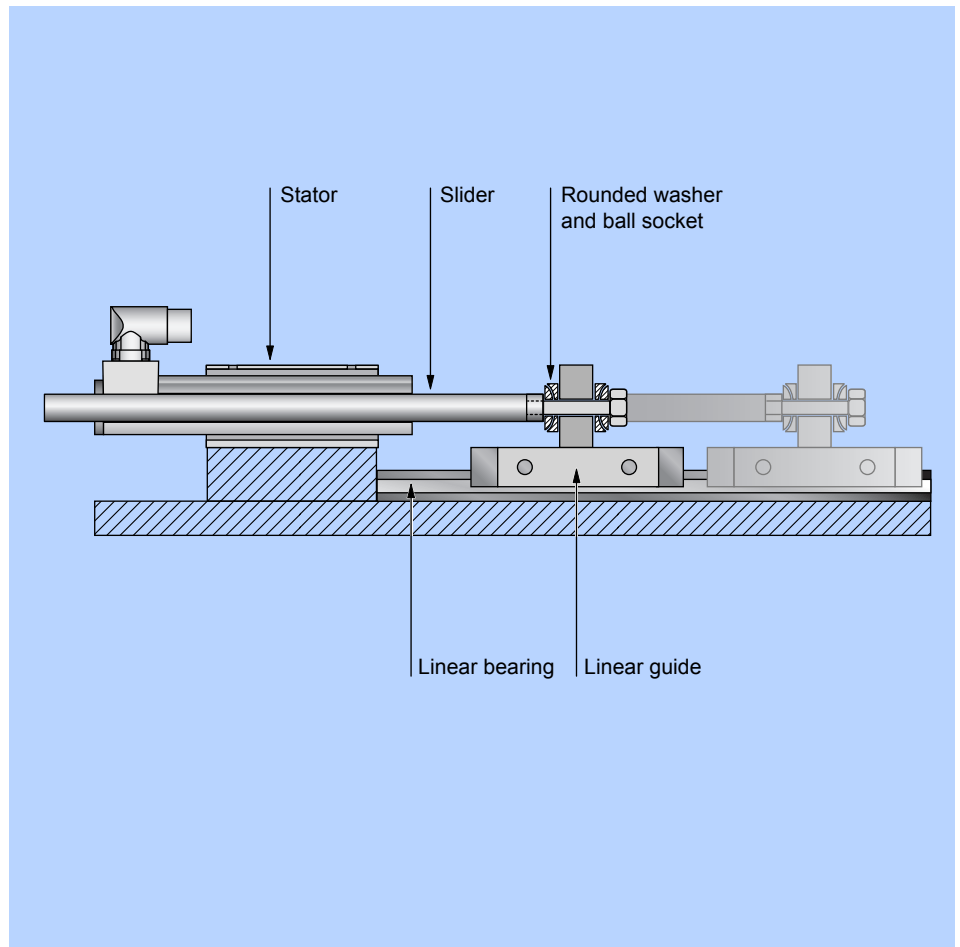

Linear Guides

In order to prevent radial loads on the slider, the load are borne by linear guides.

For short to medium strokes, LinMot has matching linear guides for each motor family in its catalog.

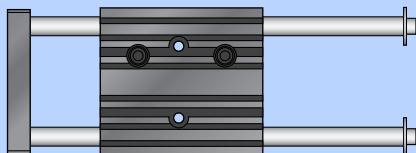

LinMot linear guides are mechanically compatible with H-guides from pneumatics manufacturers.

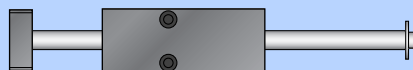

The linear guides can be optionally equipped with a mechanical brake, a fan, or a counter balance using a MagSpring, for vertical applications.

(page 479)

Flange

Various motor flanges are available for simple mounting of the stator.

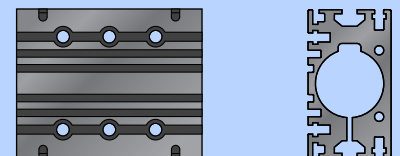

Motor flanges are available in compatible lengths for the various motors.

(page 518)

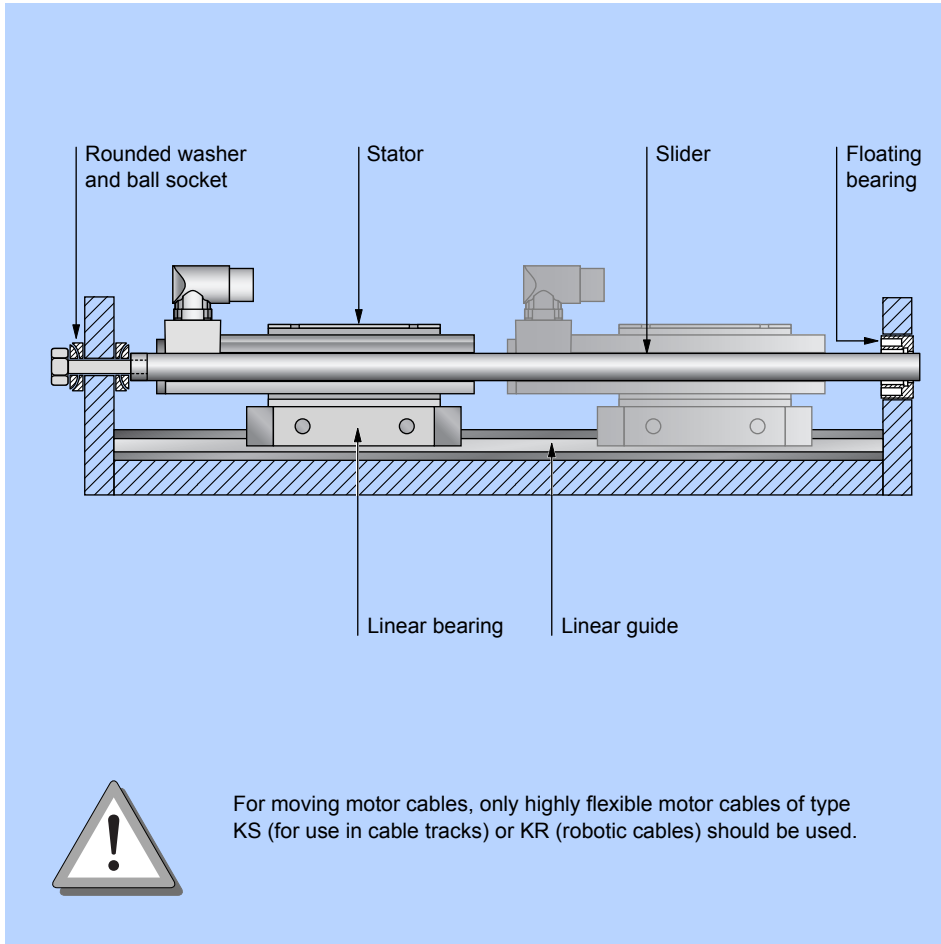

"Moving Stator" Applications

In "moving stator" applications, the slider is fixed, and the stator is the moving part.

The load is attached to the stator, which is mounted on a linear guide. In order to avoid an over-determined bearing mount, and compensate for alignment errors, the slider may be mounted on one end in a fixed bearing with a spherical axial bearing. On the opposite end, the slider is mounted in a floating bearing.

The "moving stator" installation has advantages for long-stroke motions, in terms of installation length.

Since the motor cable is always under motion in this installation type, only stators with plug connectors should be used, along with cable-chain compatible motor cables of type KS.

In some applications, multiple stators may be used on a single (long) slider

Mounting Kits for Sliders

Special mounting kits are available for mounting the slider.

The mounting kits prevent over-determined bearing mounts, and simplify alignment during installation (page 522).

Standard Motor Cables

The standard motor cable, type K, is suitable for fixed installation, and should not be used in any application where it would be flexed.

Motor cables are to be protected from mechanical damage by wireways.

Preconfigured motor cables are available in any length up to 50m. Standard lengths are available from stock (page 512).

Moving Motor Cables

For applications with moving motor cables, two different types of cables are available:

- Motor cable type KS
Highly flexible cable for use in cable tracks (flexing, but no torsion)
- Motor cable type KR
For use in robot applications, in which the cable is subject to twisting.

Moving motor cables are to be protected from mechanical damage in cable tracks or flexible cable conduits.

LinMot Sliders

LinMot sliders consist of a stainless steel tube in which the drive magnets are mounted. The slider is guided in the slide bearing of the stator, and can be the moving or the fixed part of the drive, depending on the application.

The round design causes the attractive magnetic forces between the slider and the stator to be balanced, so that the motor can be installed by hand without a problem. This is a great advantage over flat linear motors, in which large attractive forces are generated between the windings and the magnetic part.

In addition to standard sliders, LinMot has various special versions available.

Slider descriptions:

PL01- 20 x 800 / 720 - HP

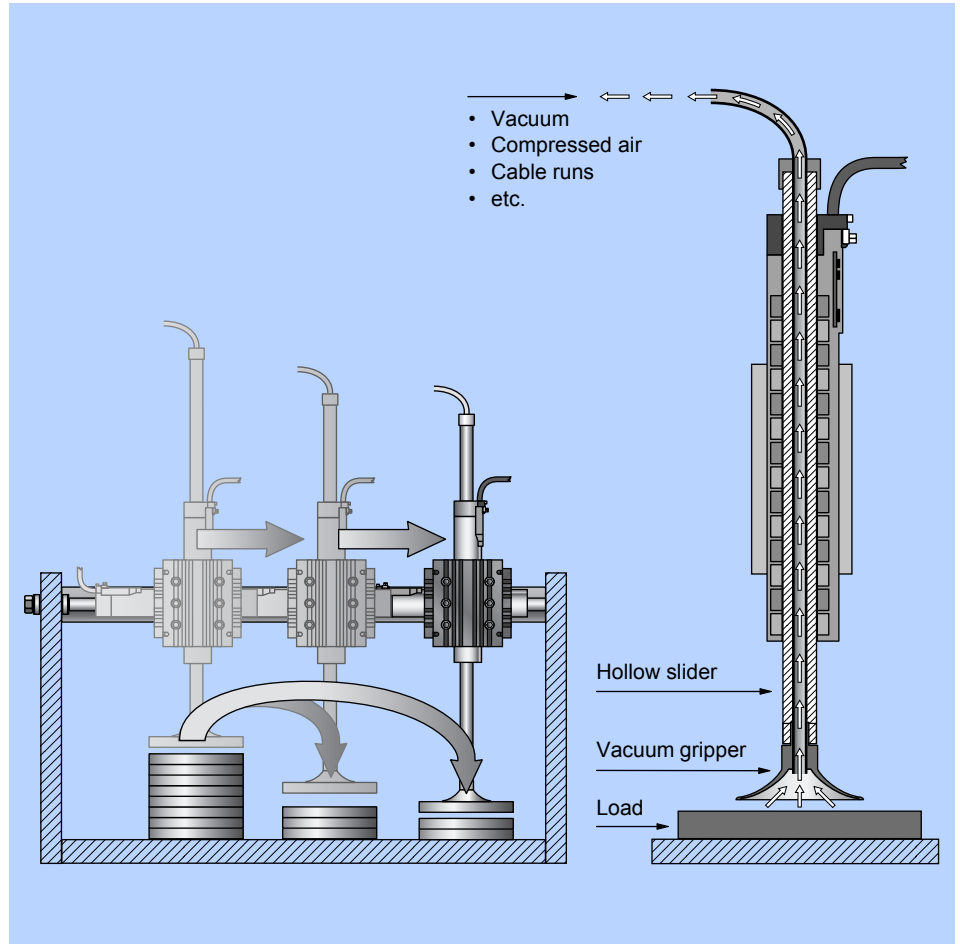
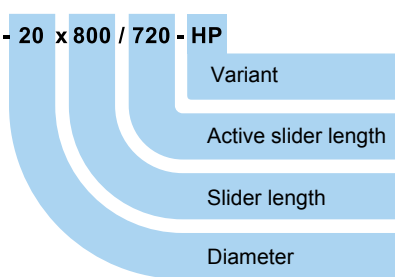

Hollow Sliders

Hollow sliders have a central hole through their length. This can be used to run compressed air, vacuum, or other media, or to run wires. Hollow sliders have the same mechanical dimensions as standard sliders.

Installation Orientation

LinMot sliders are not symmetrical. All specifications in the data sheets are based on standard slider orientation:

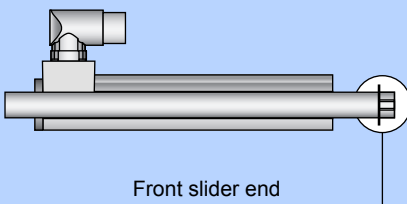

If the slider is installed backwards, the stroke and force ranges shift

Hollow Sliders

The central through-hole in the hollow slider has the following internal diameter:

- 4.2mm for Linear Motors series P01-23
- 6.5mm for Linear Motors series P01-37
- 8.5mm for Linear Motors series P01-48

Hollow sliders have a lower mass, compared to standard sliders:

- -12% for Linear Motors series P01-23
- -12% for Linear Motors series P01-37
- -10% for Linear Motors series P01-48

Both the maximum force and the continuous force of hollow slider motors are slightly reduced relative to standard motors:

- -10% for Linear Motors series P01-23
- -10% for Linear Motors series P01-37
- -10% for Linear Motors series P01-48

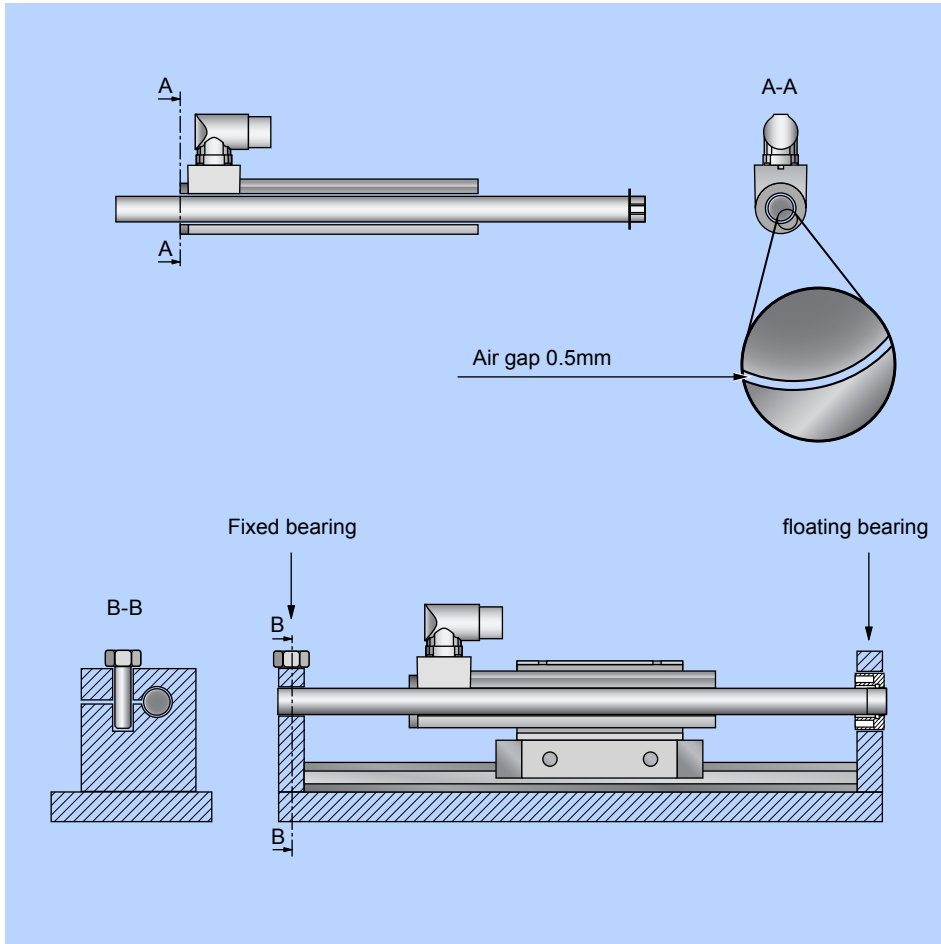

High-Clearance Sliders

High-clearance sliders have an outer diameter that is 1mm less than that of a standard slider. This means there is an air gap of 0.5 mm between the slider and the stator.

The air gap simplifies installation and alignment of the motor, and allows maintenance-free operation of the motor. Sliders with reduced diameter must be mounted at both ends, or have external bearings.

High-clearance sliders can be used with all stator types, just like standard sliders. Mechanically, they are different from the standard slider only in their diameter. Due to the smaller diameter, the technical data are slightly different from those of the standard sliders (see below).

Heavy-Duty Sliders

PL02 heavy-duty sliders have a special hard-coated surface, with a microhardness of 1000 HV 0.05. The shape and mechanical dimensions are identical to the PL01 version.

Advantages of the heavy-duty version:

- Increased resistance to dirt, especially in contact with abrasive materials.
- Longer lifespan in critical installation conditions.

The heavy-duty version is recommended for:

- Difficult access to the drive for maintenance.
- Dirt in the environment
- Motion frequency greater than 3 Hz

High-Clearance Sliders

High-clearance sliders have a 1 mm smaller diameter compared to standard sliders:

- 19mm for Linear Motors series P01-37
- 27mm for Linear Motors series P01-48

High-clearance sliders have a smaller mass compared to standard sliders:

- -10% for Linear Motors series P01-37
- - 7% for Linear Motors series P01-48

Both the maximum force and the continuous force of motors with high-clearance sliders are slightly different, compared to standard sliders:

- + 8% for Linear Motors series P01-37
- -13% for Linear Motors series P01-48

High-clearance sliders for Linear Motors Series P01-37 have, due to the use of stronger magnets, a slightly higher force than standard sliders.

Wiper Option

Wipers are mounted on the front and/or rear end of the stator, and keep the slider free of dirt.

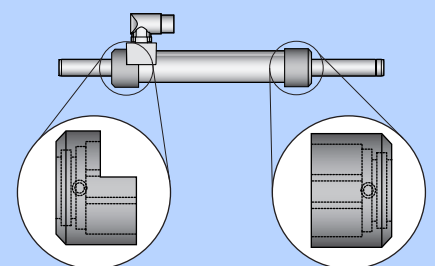

(Page 524)

Stroke-Force Diagram

Due to its design, the maximum force of a LinMot linear motor is dependent on the position of the slider in the stator. The maximum force curve is symmetrical about the center of the stroke range, which is known as the zero position (ZP). If the front slider end is moved out of the stator by the distance ZP, the slider is in the center of the stroke range. The zero position ZP is found in the data sheet for each linear motor, and is different for each motor.

In the Standard Stroke (SS) range, the motor has a constant maximum force, since the drive magnets of the slider are in the active range of the stator. This results in optimal force generation over the entire SS stroke range. The further the slide moves out of the SS stroke range, the fewer magnets are within the active part of the stator. This causes the maximum and effective force to drop off linearly at the edges of the Extended Stroke (ES). The maximum force is also dependent on the power supply voltage, and the maximum current from the Servo Drive. The maximum force, depending on the slider position, is shown for various Servo Drives in the stroke-force diagram.

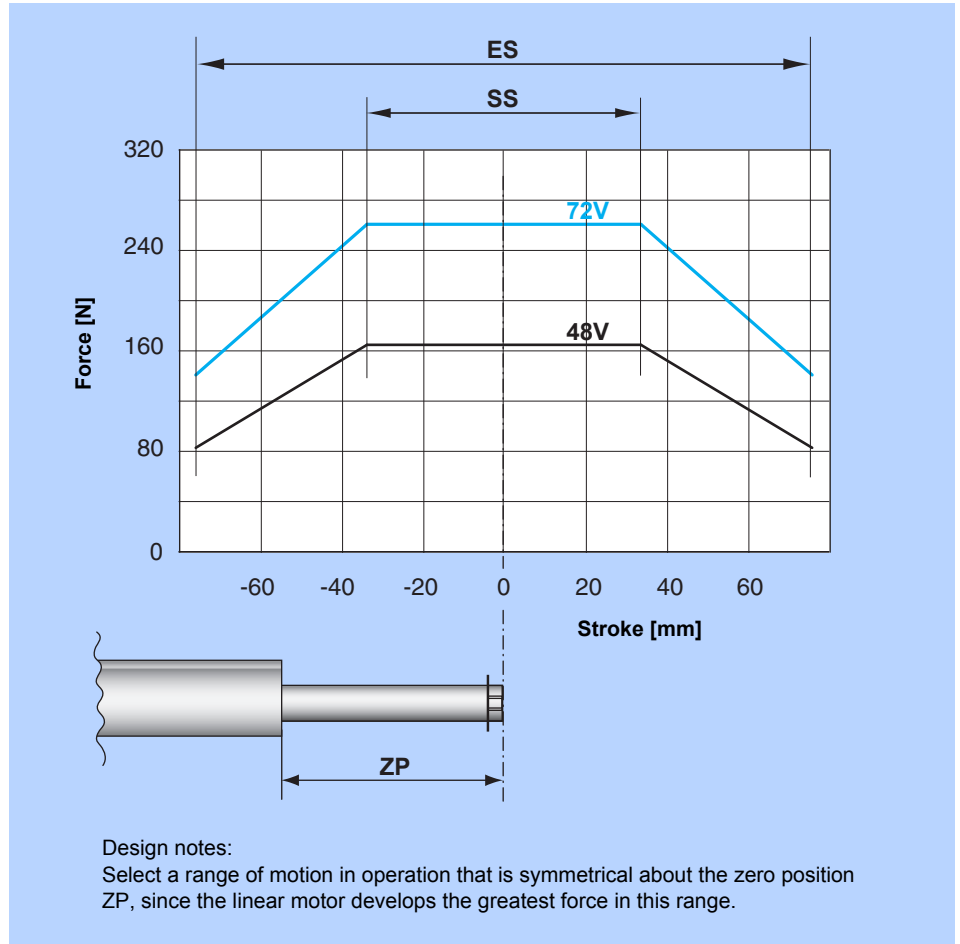

Homing

After powering up the Servo Drive, a position initialization must be carried out, in the form of a homing, to determine the zero position. The initialization can be configured by the user. It can be made either to a mechanical stop, or to a reference sensor. In case of an emergency stop, the linear motor does not need to be referenced again, since only the power supply is interrupted, while the separate logic supply remains up.

If a linear absolute encoder is used, then no homing is required.

Performance limits and thermal behavior

The performance limit of a linear motor with lower duty cycles is limited to the peak force and the maximum speed of the slider. In longer duty cycles, the continuous force of the linear motor is limited by the maximum permissible power dissipation.

This, in turn, is largely determined by the ambient temperature, cooling, and mounting of the motor. With forced cooling of the linear motor using a fan, the continuous force can be nearly doubled.

Option: MagSpring / Weight Balancer

In vertical installation applications, a weight balancer can be implemented with a MagSpring to assist the linear motor. MagSpring is a purely passive design element that generates a constant force over a defined stroke (see page 467).

Weight balancing can also be done with a mechanical spring or a pneumatic cylinder under constant pressure, mounted in parallel with the linear motor.

In the ideal case, the force of the weight balancer is selected to be the same as or slightly greater than the gravitational force. This causes the vertical axis to remain

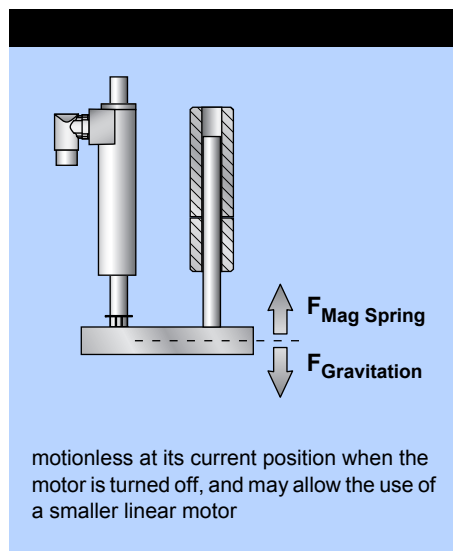

Option: Mechanical Brake

A brake prevents the motor from falling to the lower end stop when the motor is turned off in vertical installations.

LinMot linear guide models H01-37 and H01-48 have an option for installing a brake. These are controlled by the Servo Drive, and are automatically released when the motor is turned on. When the motor is turned off, or in case of a fault, the brake is automatically activated, so that the motor stays in its current position.

For horizontal installations, brakes are needed only in rare cases.

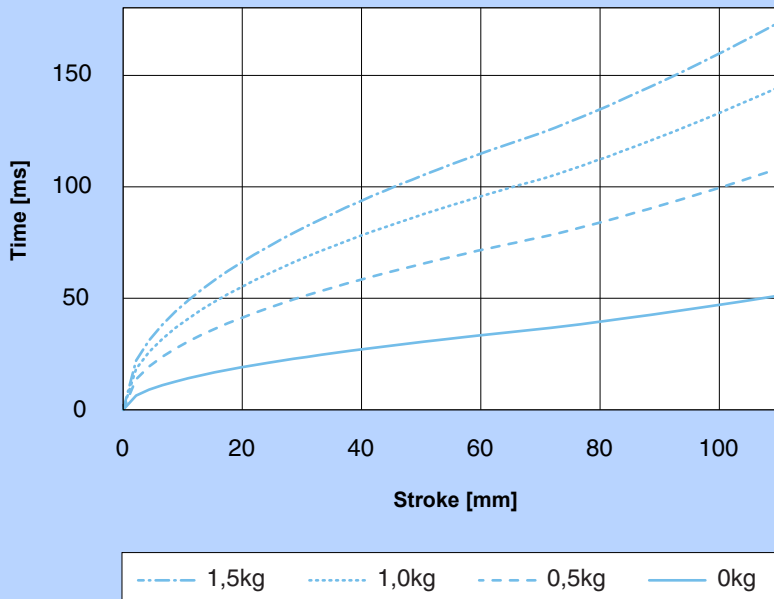

Example:

If a linear motor is to move a 0.5kg load mass by 100 mm horizontally, the positioning time, from the time the target position is given until final stop, is 100ms.

Stroke-Time Diagram

The stroke-time diagram shows the minimum movement time achievable for a horizontal point-to-point motion, depending on various load masses. The values shown in the diagram are the time from the start of the motion until final stop at the desired end position, using a time-optimized profile curve.

Stroke-time diagrams allow quick estimations of the minimum positioning time, without considering the thermal behavior of the motor in continuous operation. For a detailed analysis, LinMot Designer configuration software is available, with which entire motion sequences can be simulated and the correct motor can be determined quickly.

If the required motion times or cycles for an application are beyond the limits determined by the configuration program, then the effective performance limit must be determined with practical experiments, in conjunction with the vendor. This is the only way to capture all application-specific influences (additional friction on bearings, thermal boundary conditions, etc.).

Motor Temperature

Several absolute temperature sensors are located in the windings of LinMot stators. The absolute winding temperature in test operations can be read, and the instantaneous load on the motor can be determined.

In addition, the winding temperature can also be read during operation by the overall controller. This allows use of a diagnostic function that recognizes an increase in motor temperature during machine operation (such as in case of increasing friction), and can issue an appropriate warning.

Forced Cooling

The continuous force of the linear motor depends mainly on cooling. The values given in the data sheets for continuous force can be significantly increased with the use of forced cooling, using a fan. If a linear motor mounted using standard flanges is additionally cooled by

a fan, it can be operated with nearly double the continuous force. The same cooling effect as a fan can be obtained by feeding air between the slider and the stator via a special hole in the stator.

Option: End- and Reference-Switches

Since no mechanical components are used for force transmission in the linear motor, and the force can be limited, end position switches are not needed to protect gearboxes, spindles, etc. If end position switches are nevertheless needed for a special application, they can be connected to the LinMot drive.

As a rule, LinMot linear motors are referenced to a mechanical end stop at power-up. In applications where this is not possible or desirable, initialization can be done with a reference switch, a reference mark, or an end position switch.

Option: External Position Sensors

For high-precision applications, an optional external position measurement system can be used to increase the resolution and position accuracy beyond that of the internal measurement system.

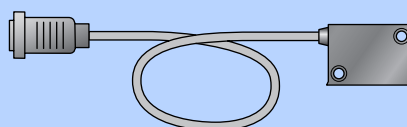

Since the principle of linear direct drives eliminates mechanical play and the external

position sensors can be placed precisely where the precision is effective, positioning accuracy in the micrometer and sub-micrometer range can be obtained.

LinMot Servo Drives can operate the linear motors with an external measurement system. Both optical and magnetic systems are suitable for this, with incremental (RS422) or sin/cos interfaces, from any manufacturer.

LinMot carries an external position sensor with an accuracy of 10 µm (see page 526).

Configuration of Linear Motors

The use of a linear drive system starts with configuration of the linear motors. To support the designer during this step, LinMot provides an easy-to-use tool, the LinMot Designer configuration program. LinMot Designer quickly calculates the parameters required for selection of a drive, based on the required motion sequences and loads, and shows them in relation to the selected motor and drive type.

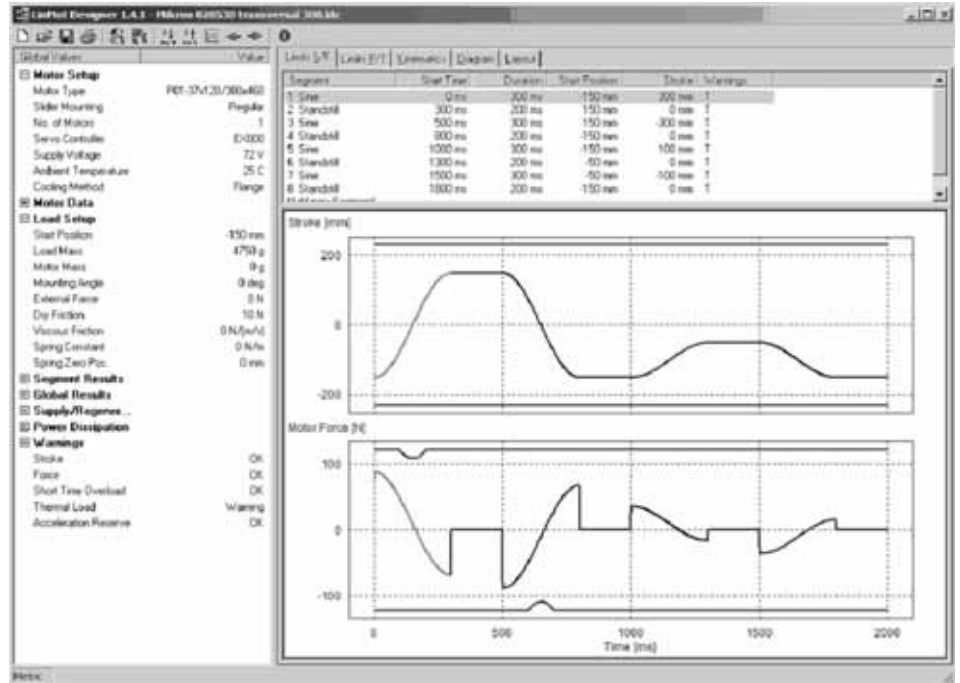

Simulation of a Motion Sequence

The LinMot Designer configuration program calculates the required data points for selecting an appropriate linear motor, such as peak force, nominal force, and maximum speed.

The global data for drive configuration are specified in a first step, such as installation orientation, load mass, friction, etc. The entire motion cycle is then divided into individual motion segments: forward motion, idle time, reverse motion, idle time, etc.

Various motion profiles are available to define motions in the individual segments, such as sinusoidal motions, motion profiles optimized for acceleration or time, etc. Additional, segment-specific data can be defined for each segment, such as increased friction, or a greater load mass during the reverse motion.

After entering the entire motion sequence, the desired motion path is simulated.

Based on the data entered, the critical kinematic data and relevant parameters for the motor are calculated. Both the short-term peak values and the characteristic data for long-term operation are calculated, and compared to those of the selected motor. If the motor performance data are exceeded by the required motion profile, then a warning is automatically given, meaning that the motor selection or the motion sequence must be adjusted.

Motor Drive Database

All data on the LinMot linear motors and Servo Drives is stored in a database in LinMot Designer.

Based on the linear motor and Servo Drive selected, LinMot Designer calculates the drive-specific data, such as maximum and continuous force, maximum speed, etc.

The motor data relevant to the simulation, such as slider or stator mass, are automatically transferred.

Based on the mechanical dimensions, a drawing is generated with the optimal installation orientation.

Dynamic Limits

Based on the motion sequence entered, kinematic data are calculated for each individual segment and for the entire sequence.

The kinematic data from the simulation are displayed graphically in a window, together with the motor limits.

This allows rapid analysis of whether the selected linear motor can follow the required motion profile with the defined load mass.

If the application cannot be realized with the selected motor, then a warning is automatically shown.

Continuous Operation

LinMot Designer always assumes for the simulation that the motion sequences entered are executed in continuous operation without pause.

LinMot Designer calculates the power dissipation in continuous operation for the configuration, based on the motion sequence entered, and compares this to the maximum permissible power dissipation of the linear motor.

If the maximum power dissipation of the selected linear motor is exceeded in continuous operation, then an appropriate warning is automatically displayed.

Moving Slider

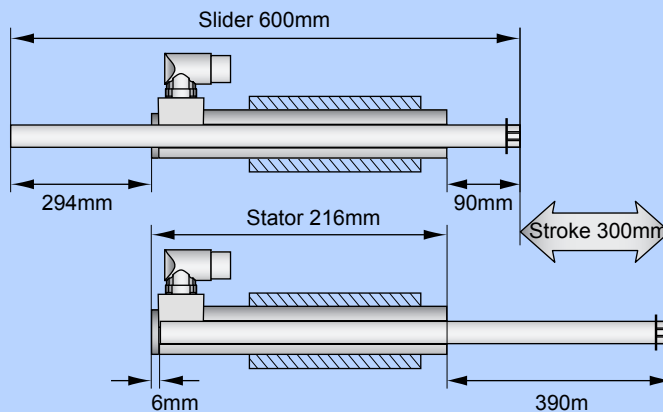

Moving Stator

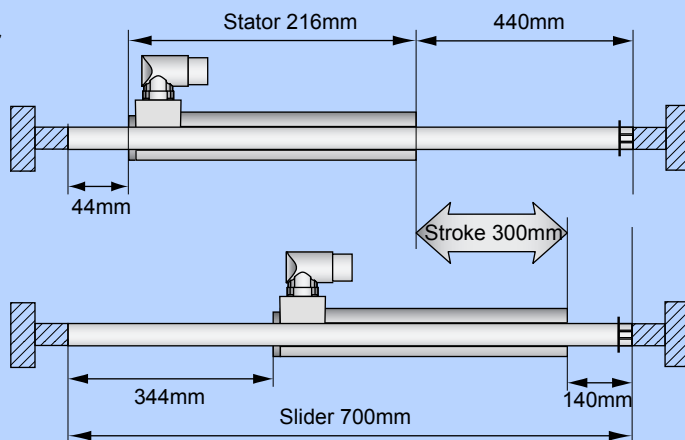

Graphic Display of Results

The motion and force requirements are shown in two graphical windows, together with the motor limits. The graphic representation of the results means that it can be determined at a glance which motion segments must be more closely scrutinized, and how much reserve force the selected linear motor has in the individual segments.

Graphic display of the results also allows simple optimization of the command sequences. For example, individual segments can be optimized for minimum motion times, or entire motion cycles for minimal power dissipation.

Installation Orientation

Another graphic shows the mechanical dimensions of the linear motor, with the slider at the innermost and outermost positions. For applications with a moving stator, the position of the stator is shown at the two outermost positions.

The dimensions, together with detailed motor data and the results of the configuration, can be stored or printed out for documentation purposes.



LinMot Designer can be downloaded from the home page at www.LinMot.com.

Optimization

Graphic display of the results allows simple and rapid optimization according to various criteria:

- Short motion time
Optimization for the shortest possible positioning time
- Minimum cycle time
Optimization for the shortest cycle time for an entire motion sequence
- Minimum power dissipation
Optimization for minimal power dissipation for the entire motion

Automatic Warnings

If the motor limits are exceeded, an appropriate warning is automatically issued:

- Stroke
Allowable stroke range exceeded
- Force
Maximum force not sufficient
- Overload
Warning of short-term overload, and thermal overload in continuous operation
- Acceleration reserve
The minimum acceleration reserve of 10 N/kg was not met

Calculation of Power Supply

To estimate the supplied power required, and to size the power supply, LinMot Designer calculates both the peak value and the effective value for the supplied power.

Motor Family P01-23x80

39



Motor Family P01-23x160

63



Motor Family P01-37x120

85



Motor Family P01-37x240

111



Motor Family P01-48x240

P01-48x360

137 / 165



Motor Families P10x70

441



Motor Family P02-23Sx80

199



Motor Family P01-37Sx60

241



Motor Family P01-37Sx120

259



Linear Motors INOX IP69K

277



Linear Motors ATEX

289



Linear-Rotary-Motors

299



P01-23x80 Series

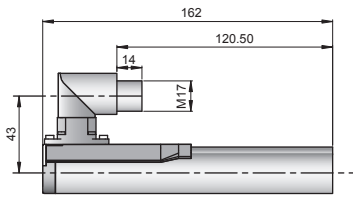

P01-23x80-R

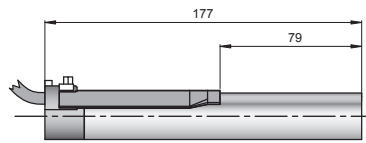

P01-23x80-D100
P01-23x80-R20

P01-23x160 Series

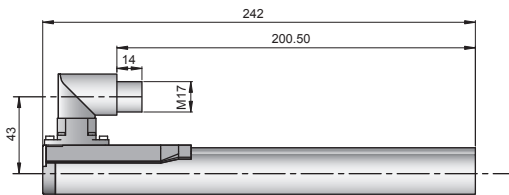

P01-23x160-R P01-23x160H-HP-R
P01-23x160F-R

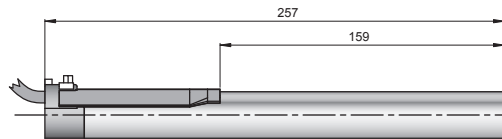

P01-23x160-D100 P01-23x160F-R20
P01-23x160-R20 P01-23x160H-HP-R20

P01-37x120 Series

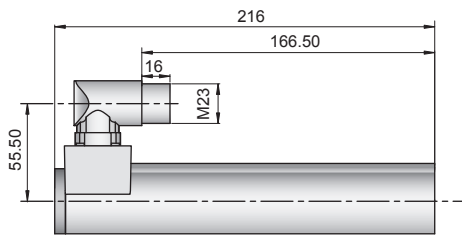

P01-37x120-C
P01-37x120F-HP-C

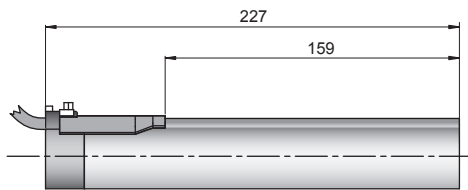

P01-37x120-P150 P01-37x120F-HP-C20
P01-37x120-C20

P01-37x240 Series

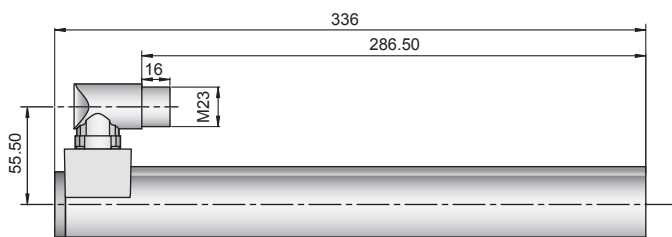

P01-37x240-C
P01-37x240F-C

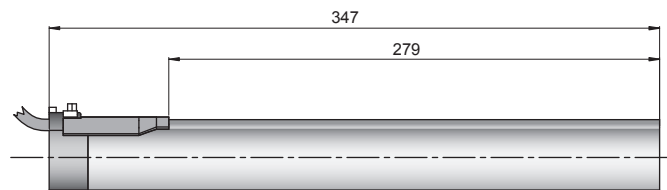

P01-37x240-P150 P01-37x240F-C20
P01-37x240-C20

P01-48x240 Series

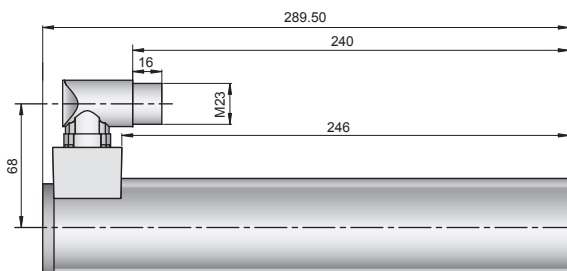

P01-48x240-C
P01-48x240F-C

P01-48x360 Series

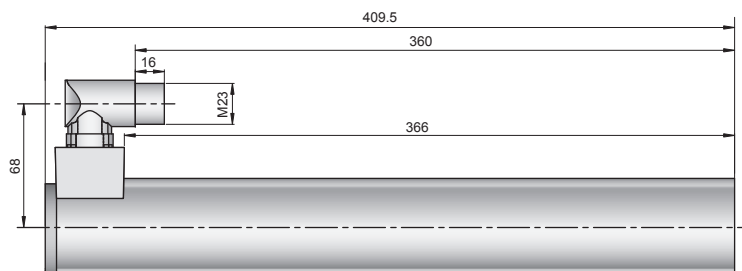

P01-48x360F-C

Dimensions in mm

P02-23Sx80 Series

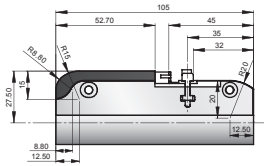

P02-23Sx80-F

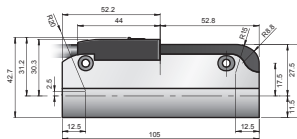

P02-23Sx80F-HP-K

P01-37Sx60 Series

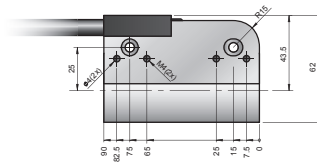

P01-37Sx60-HP-N

P01-37Sx120 Series

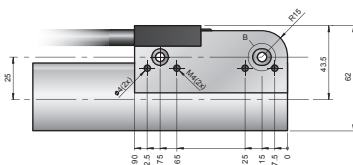

P01-37Sx120F-HP-N

Technical Data and Abbreviations

A data sheet is available for every LinMot linear motor, with the technical data, dimensions, stroke-force and path-time diagram. The data and parameters specified in the data sheets are clarified further below.

Extended Stroke Range ES:

Maximum travel distance of the linear motor

Standard Stroke Range SS

Stroke range in which the linear motor develops its greatest force, since the magnets move within all of the windings in the short stroke range. The linear motor force is constant throughout the short stroke range.

peak force E100/E1001

Maximum linear motor force when controlled by a Servo Drive of series E100 (48 VDC, 3A phase current) or series E1001 (72 VDC, 8A phase current)

peak force E1100/HC

Maximum linear motor force when controlled by a Servo Drive of series E1100 (72 VDC, 8A phase current), E1100-HC (72 VDC, 15A) or E1100-XC (72 VDC, 25A)

Continuous force

Force that the linear motor can apply permanently in the SS stroke range, when mounted with a standard flange at 25°C ambient temperature.

Continuous force with fan

Force that the linear motor can apply permanently in the SS stroke range, when mounted with a standard flange with a fan, at 25°C ambient temperature.

Boundary force

Peak force that the motor can apply at both ends of the stroke range S.

Force constant

The force constant describes the relationship between the phase current and the force generated in the SS range of the linear motor.

Max. phase current

Maximum phase current (I_{peak}) at 72 VDC or 48 VDC supply voltage

Max. speed

Maximum speed at 72 VDC or 48 VDC supply voltage

Phase resistance

Phase resistance at 25°C or maximum winding temperature

Phase inductivity

Connection inductivity of a motor phase

Thermal resistance

Thermal resistance of the linear motor with standard flange. Determines the maximum increase in temperature for a given power dissipation level

Thermal time constant

Is the typical reaction time for temperature changes in the stator mounted in a standard flange.

Stator diameter

Outer diameter of the stator, in millimeters. Note that this number is an average value. Precise dimensions are found in the design drawing

Stator length

Length of the stator

Stator mass

Mass of the stator

Slider diameter

Diameter of the slider

Slider length

Length of the slider from end to end

Slider mass

Mass of the slider

Repeatability

Maximum deviation from the intended position, in mm, when traveling to the same position under identical conditions.

Linearity

Absolute accuracy of the drive, relative to the maximum stroke S of the linear motor.

Repeatability with EPS

Maximum deviation from the intended position, in mm, when traveling to the same position under identical conditions with external position sensors.

Linearity with EPS

Maximum linearity error when positioning with external sensors.



P01-23x80/10x50 40

P01-23x80/30x90 42

P01-23x80/50x110 44

P01-23x80/80x140 46

P01-23x80/150x210 48

P01-23x80/210x270 50

P01-23x80/280x340 52

P01-23x80/340x400 54

P01-23x80/440x500 56

P01-23x80/620x680 58

P01-23x80/710x770 60

Max. Stroke: 50mm
Peak Force: 39N

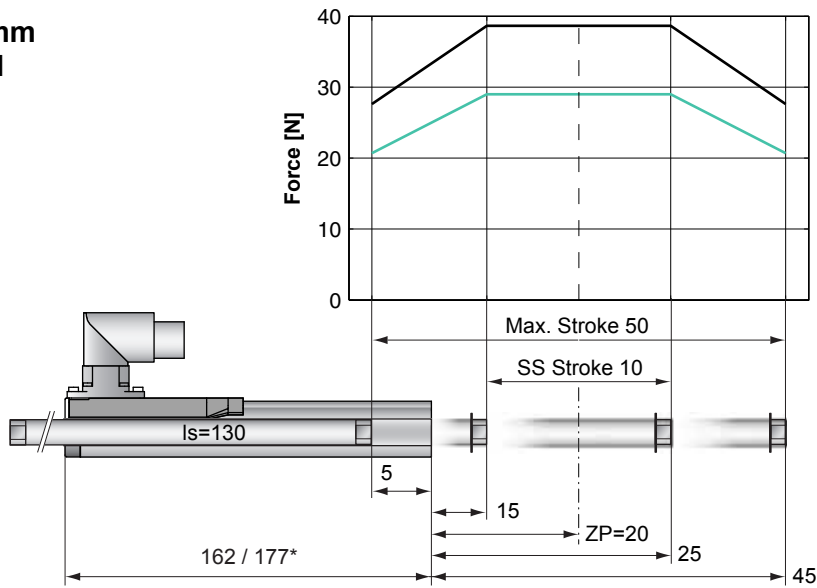

Standard Winding:
 — E1100, 72VDC & E1001, 72VDC
 — E100, 48VDC

Dimensions in mm
 *Cable Type

Motor Specification

	P01-	Connector Type	Cable Type
		23x80/10x50-R	23x80/10x50-D100 23x80/10x50-R20
Extended Stroke ES	mm (in)	50 (1.97)	50 (1.97)
Standard Stroke SS	mm (in)	10 (0.39)	10 (0.39)
Peak Force E1100 / E1001	N (lbf)	39 (8.7)	39 (8.7)
Peak Force E100	N (lbf)	29 (6.5)	29 (6.5)
Cont. Force	N (lbf)	8 (1.7)	8 (1.7)
Cont. Force Fan cooling	N (lbf)	14 (3.2)	14 (3.2)
Border Force	%	71	71
Force Constant	N/A (lbf/A)	9.7 (2.17)	9.7 (2.17)
Max. Current @ 72VDC	A	4.0	4.0
Max. Current @ 48VDC	A	3.8	3.8
Max. Velocity @ 72VDC	m/s (in/s)	6.9 (270)	6.9 (270)
Max. Velocity @ 48VDC	m/s (in/s)	4.6 (180)	4.6 (180)
Phase Resist. 25/80 °C	Ohm	10.3/12.5	10.3/12.5
Phase Inductance	mH	1.4	1.4
Thermal Resistance	°K/W	7.0	7.0
Thermal Time Const.	sec	1600	1600
Stator Diameter	mm (in)	23 (0.91)	23 (0.91)
Stator Length	mm (in)	162 (6.38)	177 (6.97)
Stator Mass	g (lb)	265 (0.58)	265 (0.58)
Slider Diameter	mm (in)	12 (0.47)	12 (0.47)
Slider Length	mm (in)	130 (5.12)	130 (5.12)
Slider Mass	g (lb)	89 (0.20)	89 (0.20)
Position Repeatability	mm (in)	±0.05 (±0.0020)	±0.05 (±0.0020)
Linearity	%	±0.70	±0.70
Repeatability with EPS	mm (in)	±0.01 (±0.0004)	±0.01 (±0.0004)
Linearity with EPS	mm (in)	±0.01 (±0.0004)	±0.01 (±0.0004)

Position-Time Diagram

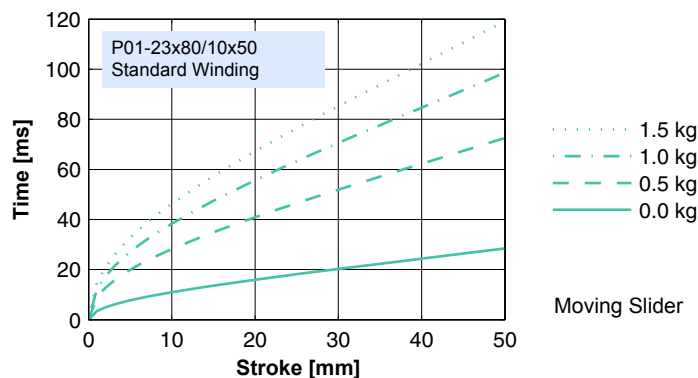

Connector Type

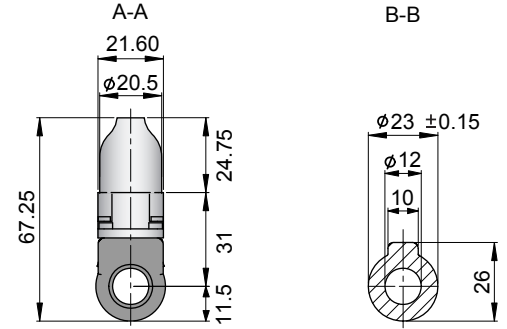
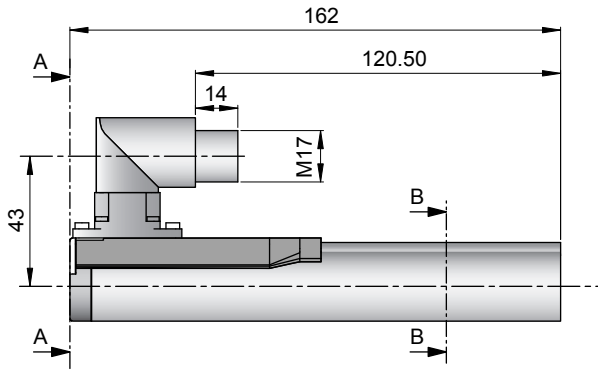

Linear Motor		Stator		Slider	
Type	Art.No	Type	Art. No.	Type	Art No.
P01-23x80/10x50-R	-->	PS01-23x80-R	0150-1233	& PL01-12x130/80	0150-1399

Cable Type

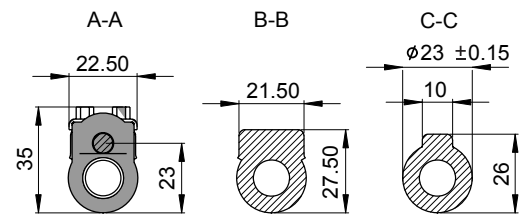
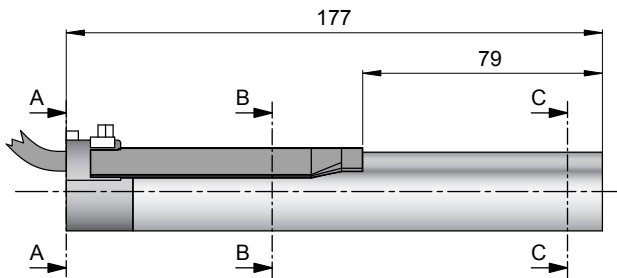

Linear Motor		Stator		Slider	
Type	Art.No	Type	Art. No.	Type	Art No.
P01-23x80/10x50-D100	-->	PS01-23x80-D100	0150-1201	& PL01-12x130/80	0150-1399
P01-23x80/10x50-R20	-->	PS01-23x80-R20	0150-1241	& PL01-12x130/80	0150-1399

Slider

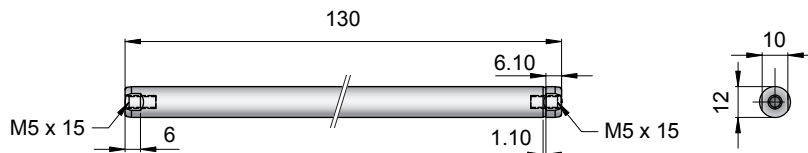

Standard Type	Slider Standard	PL01-12x130/80	0150-1399
Special Sliders	Heavy Duty Slider with WC/C-Coating	PL02-12x130/80	0150-1424
	Hollow Slider hole diameter 4.2mm	PL01-12x130/80-L	0150-1445

Connectors

Motor Connector Wiring

Cable Length:
P01-23x80/...x... 1.0m
P01-23x80/...x...-R20 0.2m

		P01-23...-R	P01-23...-R20	P01-23...-
Ph 1+	red	1	1	
Ph 1-	pink	2	6	
Ph 2+	blue	3	2	
Ph 2-	grey	4	7	
+5VDC	white	A	3	
GND	inner Shield	B	8	
Sine	yellow	C	4	
Cosine	green	D	9	
Temp.	black	E	5	
Shield	outer Shield	Case	Case	

Accessoires

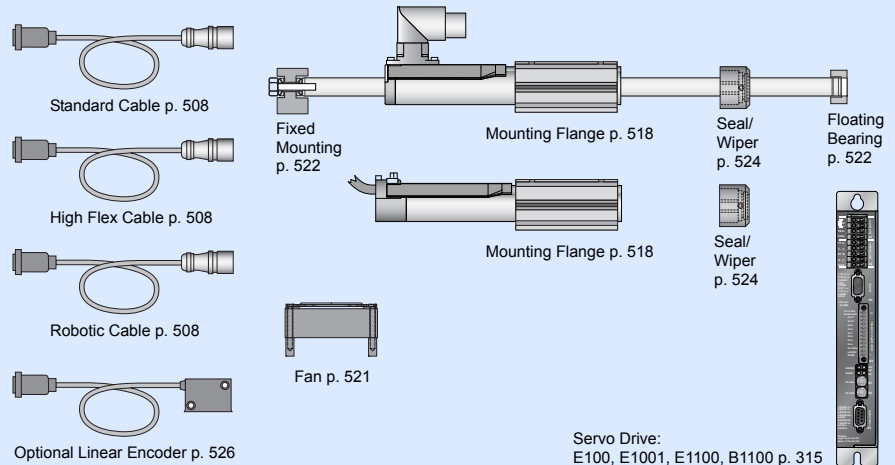

Servo Drive:
E100, E1001, E1100, B1100 p. 315

Max. Stroke: 90mm
Peak Force: 44N

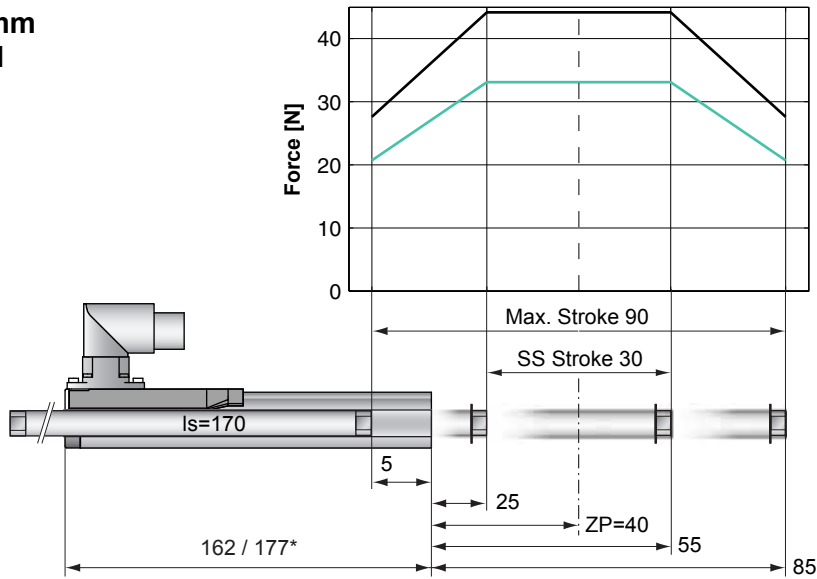

Standard Winding:
 — E1100, 72VDC & E1001, 72VDC
 — E100, 48VDC

Dimensions in mm
 *Cable Type

Motor Specification

	P01-	Connector Type	Cable Type
		23x80/30x90-R	23x80/30x90-D100 23x80/30x90-R20
Extended Stroke ES	mm (in)	90 (3.54)	90 (3.54)
Standard Stroke SS	mm (in)	30 (1.18)	30 (1.18)
Peak Force E1100 / E1001	N (lbf)	44 (9.9)	44 (9.9)
Peak Force E100	N (lbf)	33 (7.4)	33 (7.4)
Cont. Force	N (lbf)	9 (2.0)	9 (2.0)
Cont. Force Fan cooling	N (lbf)	16 (3.7)	16 (3.7)
Border Force	%	63	63
Force Constant	N/A (lbf/A)	11.0 (2.48)	11.0 (2.48)
Max. Current @ 72VDC	A	4.0	4.0
Max. Current @ 48VDC	A	3.8	3.8
Max. Velocity @ 72VDC	m/s (in/s)	6.0 (236)	6.0 (236)
Max. Velocity @ 48VDC	m/s (in/s)	4.0 (157)	4.0 (157)
Phase Resist. 25/80 °C	Ohm	10.3/12.5	10.3/12.5
Phase Inductance	mH	1.4	1.4
Thermal Resistance	°K/W	7.0	7.0
Thermal Time Const.	sec	1600	1600
Stator Diameter	mm (in)	23 (0.91)	23 (0.91)
Stator Length	mm (in)	162 (6.38)	177 (6.97)
Stator Mass	g (lb)	265 (0.58)	265 (0.58)
Slider Diameter	mm (in)	12 (0.47)	12 (0.47)
Slider Length	mm (in)	170 (6.69)	170 (6.69)
Slider Mass	g (lb)	118 (0.26)	118 (0.26)
Position Repeatability	mm (in)	±0.05 (±0.0020)	±0.05 (±0.0020)
Linearity	%	±0.45	±0.45
Repeatability with EPS	mm (in)	±0.01 (±0.0004)	±0.01 (±0.0004)
Linearity with EPS	mm (in)	±0.01 (±0.0004)	±0.01 (±0.0004)

Position-Time Diagram

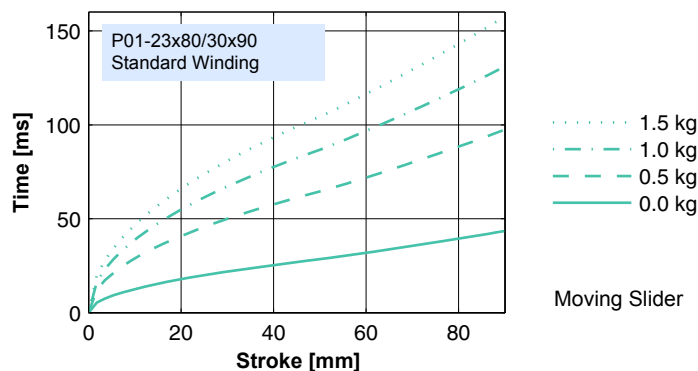

Connector Type

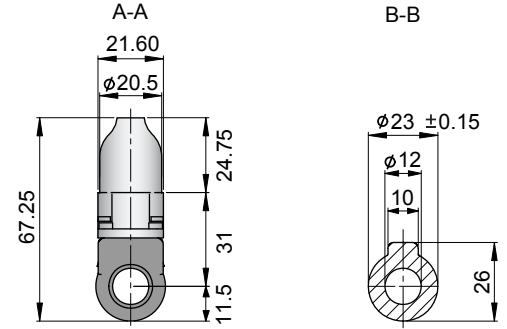
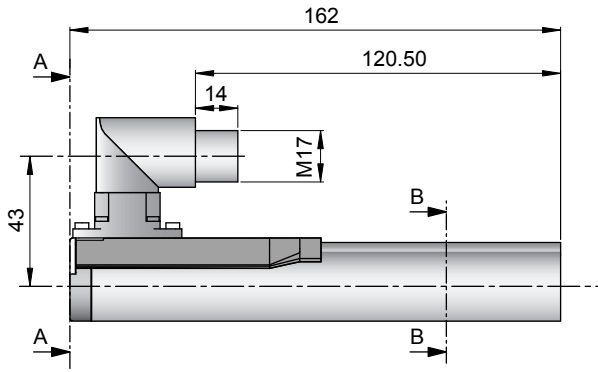

Linear Motor		Stator		Slider		
Type	Art.No	Type	Art. No.	Type	Art No.	
P01-23x80/30x90-R	-->	PS01-23x80-R	0150-1233	&	PL01-12x170/120	0150-1301

Cable Type

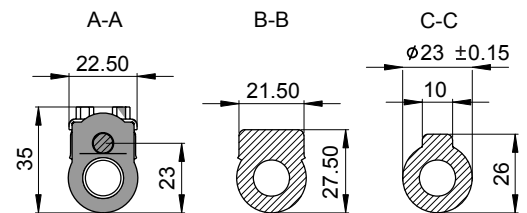
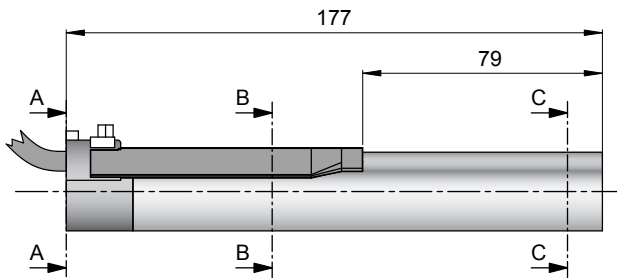

Linear Motor		Stator		Slider		
Type	Art.No	Type	Art. No.	Type	Art No.	
P01-23x80/30x90-D100	-->	PS01-23x80-D100	0150-1201	&	PL01-12x170/120	0150-1301
P01-23x80/30x90-R20	-->	PS01-23x80-R20	0150-1241	&	PL01-12x170/120	0150-1301

Slider

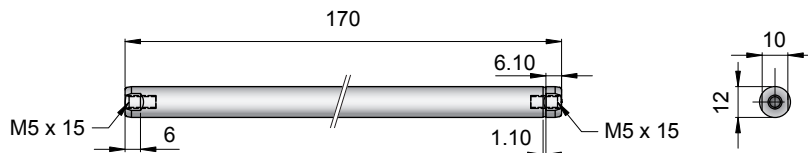

Standard Type	Slider Standard	PL01-12x170/120	0150-1301
Special Sliders	Heavy Duty Slider with WC/C-Coating	PL02-12x170/120	0150-1303
	Hollow Slider hole diameter 4.2mm	PL01-12x170/120-L	0150-1375

Connectors

Motor Connector Wiring

Cable Length:
P01-23x80/...x... 1.0m
P01-23x80/...x...-R20 0.2m

		P01-23...-R	P01-23...-R20	P01-23...-
Ph 1+	red	1	1	
Ph 1-	pink	2	6	
Ph 2+	blue	3	2	
Ph 2-	grey	4	7	
+5VDC	white	A	3	
GND	inner Shield	B	8	
Sine	yellow	C	4	
Cosine	green	D	9	
Temp.	black	E	5	
Shield	outer Shield	Case	Case	

Accessoires

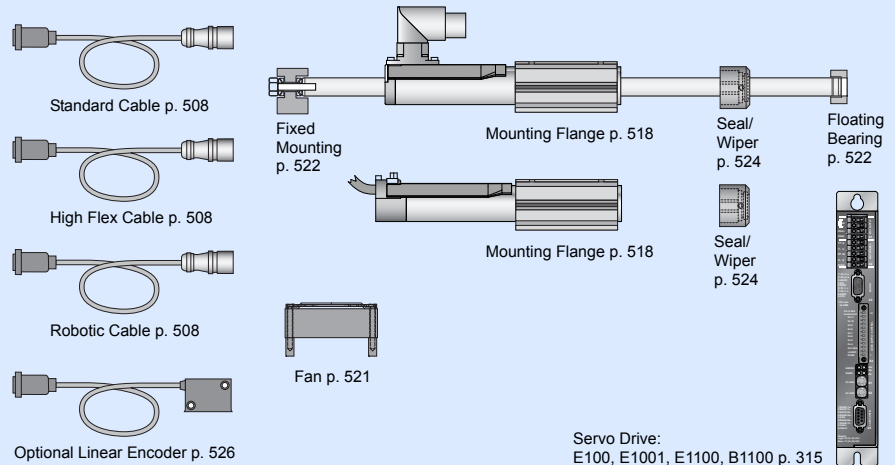

Max. Stroke: 110mm
Peak Force: 44N

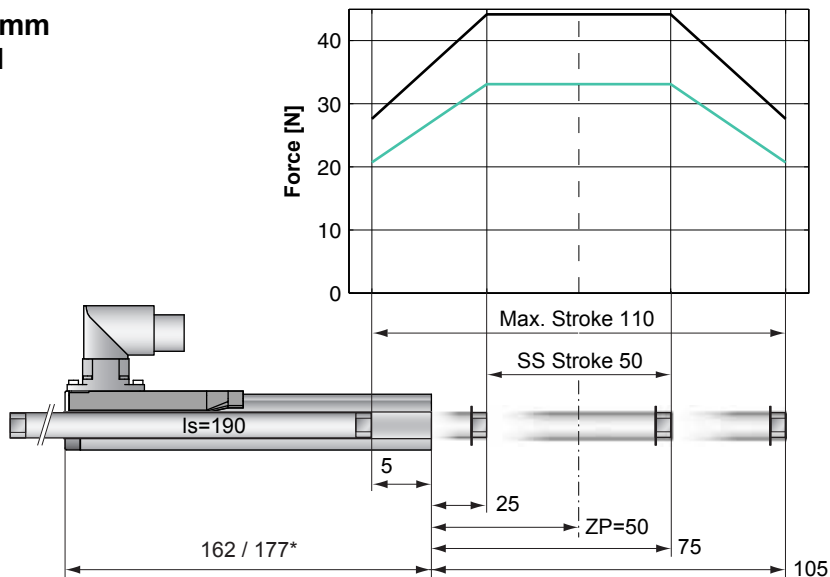

Standard Winding:
 — E1100, 72VDC & E1001, 72VDC
 — E100, 48VDC

Dimensions in mm
 *Cable Type

Motor Specification

	P01-	Connector Type	Cable Type
		23x80/50x110-R	23x80/50x110-D100 23x80/50x110-R20
Extended Stroke ES	mm (in)	110 (4.33)	110 (4.33)
Standard Stroke SS	mm (in)	50 (1.97)	50 (1.97)
Peak Force E1100 / E1001	N (lbf)	44 (9.9)	44 (9.9)
Peak Force E100	N (lbf)	33 (7.4)	33 (7.4)
Cont. Force	N (lbf)	9 (2.0)	9 (2.0)
Cont. Force Fan cooling	N (lbf)	16 (3.7)	16 (3.7)
Border Force	%	63	63
Force Constant	N/A (lbf/A)	11.0 (2.48)	11.0 (2.48)
Max. Current @ 72VDC	A	4.0	4.0
Max. Current @ 48VDC	A	3.8	3.8
Max. Velocity @ 72VDC	m/s (in/s)	6.0 (236)	6.0 (236)
Max. Velocity @ 48VDC	m/s (in/s)	4.0 (157)	4.0 (157)
Phase Resist. 25/80 °C	Ohm	10.3/12.5	10.3/12.5
Phase Inductance	mH	1.4	1.4
Thermal Resistance	°K/W	7.0	7.0
Thermal Time Const.	sec	1600	1600
Stator Diameter	mm (in)	23 (0.91)	23 (0.91)
Stator Length	mm (in)	162 (6.38)	177 (6.97)
Stator Mass	g (lb)	265 (0.58)	265 (0.58)
Slider Diameter	mm (in)	12 (0.47)	12 (0.47)
Slider Length	mm (in)	190 (7.48)	190 (7.48)
Slider Mass	g (lb)	135 (0.30)	135 (0.30)
Position Repeatability	mm (in)	±0.05 (±0.0020)	±0.05 (±0.0020)
Linearity	%	±0.40	±0.40
Repeatability with EPS	mm (in)	±0.01 (±0.0004)	±0.01 (±0.0004)
Linearity with EPS	mm (in)	±0.01 (±0.0004)	±0.01 (±0.0004)

Position-Time Diagram

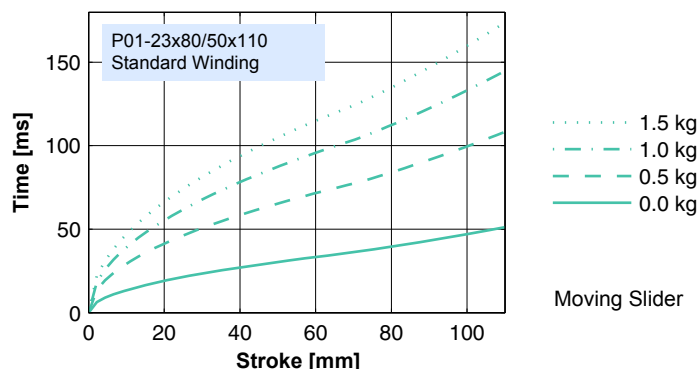

Moving Slider

Connector Type

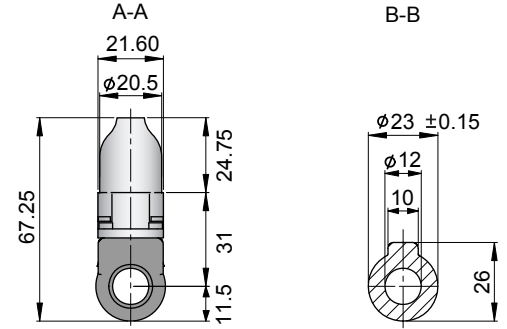
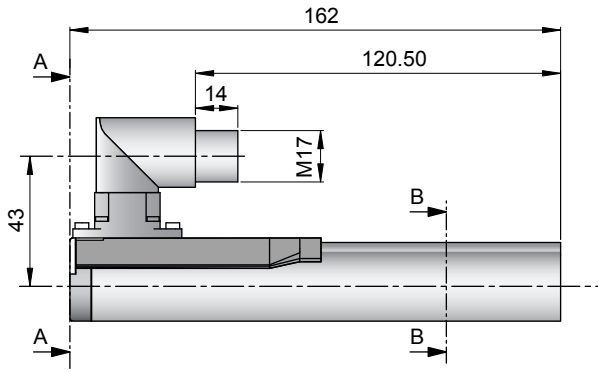

Linear Motor		Stator		Slider	
Type	Art.No	Type	Art. No.	Type	Art No.
P01-23x80/50x110-R	-->	PS01-23x80-R	0150-1233	& PL01-12x190/140	0150-1302

Cable Type

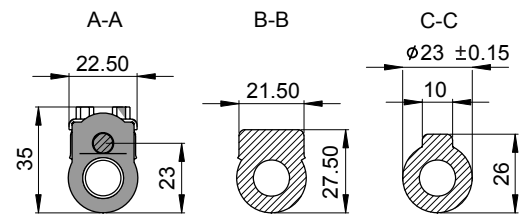
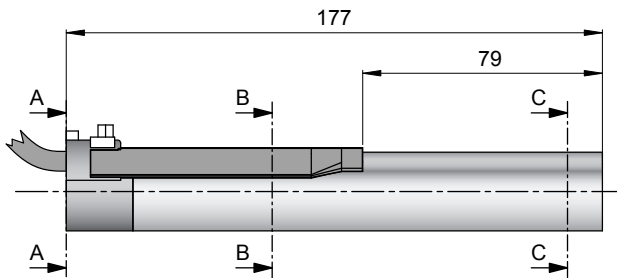

Linear Motor		Stator		Slider	
Type	Art.No	Type	Art. No.	Type	Art No.
P01-23x80/50x110-D100	-->	PS01-23x80-D100	0150-1201	& PL01-12x190/140	0150-1302
P01-23x80/50x110-R20	-->	PS01-23x80-R20	0150-1241	& PL01-12x190/140	0150-1302

Slider

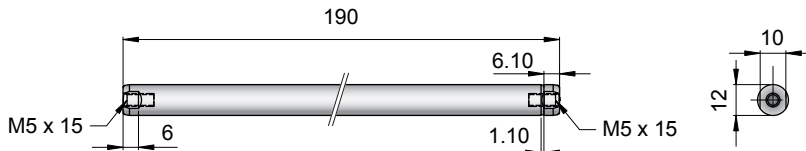

Standard Type	Slider Standard	PL01-12x190/140	0150-1302
Special Sliders	Heavy Duty Slider with WC/C-Coating	PL02-12x190/140	0150-1304
	Hollow Slider hole diameter 4.2mm	PL01-12x190/140-L	0150-1478

Connectors

Motor Connector Wiring

Cable Length:
P01-23x80/...x... 1.0m
P01-23x80/...x...-R20 0.2m

		P01-23...-R	P01-23...-R20	P01-23....
Ph 1+	red	1	1	
Ph 1-	pink	2	6	
Ph 2+	blue	3	2	
Ph 2-	grey	4	7	
+5VDC	white	A	3	
GND	inner Shield	B	8	
Sine	yellow	C	4	
Cosine	green	D	9	
Temp.	black	E	5	
Shield	outer Shield	Case	Case	

Accessoires

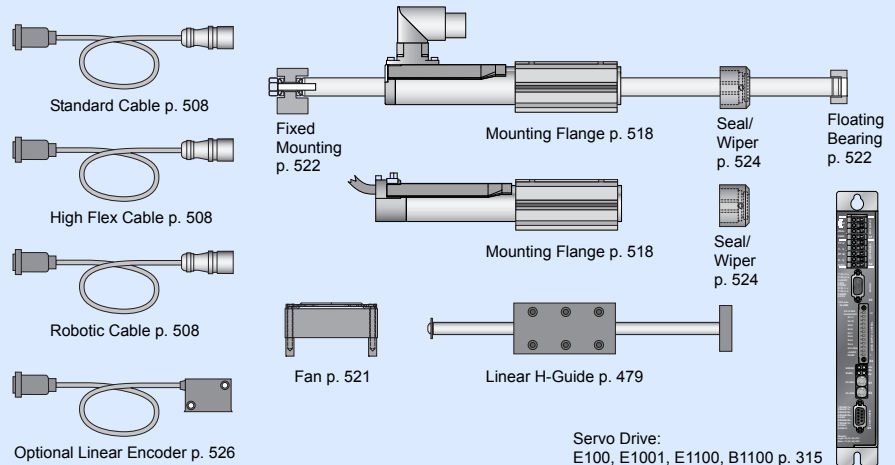

Max. Stroke: 140mm
Peak Force: 44N

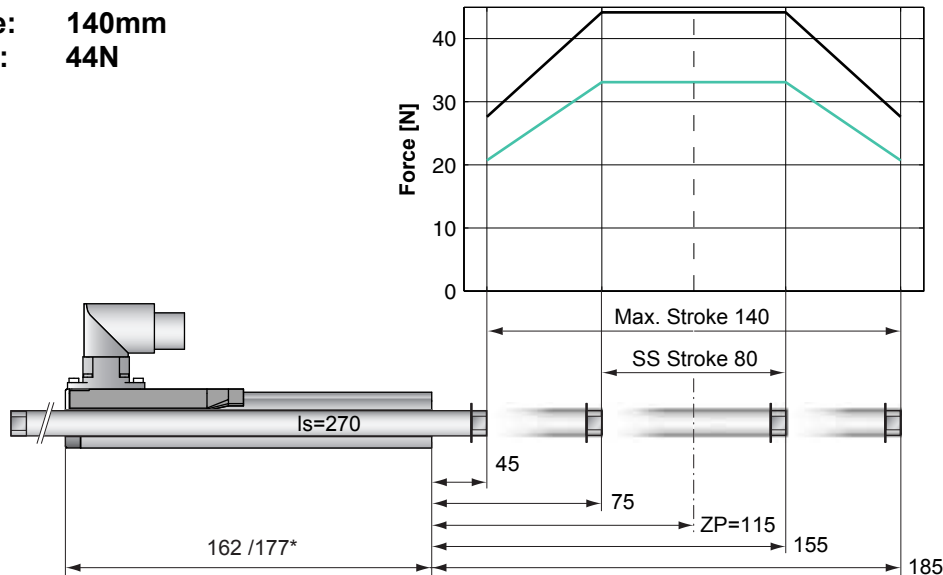

Standard Winding:

- E1100, 72VDC & E1001, 72VDC
- E100, 48VDC

Dimensions in mm
 *Cable Type

Motor Specification

	P01-	Connector Type	Cable Type
		23x80/80x140-R	23x80/80x140-D100 23x80/80x140-R20
Extended Stroke ES	mm (in)	140 (5.51)	140 (5.51)
Standard Stroke SS	mm (in)	80 (3.15)	80 (3.15)
Peak Force E1100 / E1001	N (lbf)	44 (9.9)	44 (9.9)
Peak Force E100	N (lbf)	33 (7.4)	33 (7.4)
Cont. Force	N (lbf)	9 (2.0)	9 (2.0)
Cont. Force Fan cooling	N (lbf)	16 (3.7)	16 (3.7)
Border Force	%	63	63
Force Constant	N/A (lbf/A)	11.0 (2.48)	11.0 (2.48)
Max. Current @ 72VDC	A	4.0	4.0
Max. Current @ 48VDC	A	3.8	3.8
Max. Velocity @ 72VDC	m/s (in/s)	6.0 (236)	6.0 (236)
Max. Velocity @ 48VDC	m/s (in/s)	4.0 (157)	4.0 (157)
Phase Resist. 25/80 °C	Ohm	10.3/12.5	10.3/12.5
Phase Inductance	mH	1.4	1.4
Thermal Resistance	°K/W	7.0	7.0
Thermal Time Const.	sec	1600	1600
Stator Diameter	mm (in)	23 (0.91)	23 (0.91)
Stator Length	mm (in)	162 (6.38)	177 (6.97)
Stator Mass	g (lb)	265 (0.58)	265 (0.58)
Slider Diameter	mm (in)	12 (0.47)	12 (0.47)
Slider Length	mm (in)	270 (10.63)	270 (10.63)
Slider Mass	g (lb)	171 (0.38)	171 (0.38)
Position Repeatability	mm (in)	±0.05 (±0.0020)	±0.05 (±0.0020)
Linearity	%	±0.35	±0.35
Repeatability with EPS	mm (in)	±0.01 (±0.0004)	±0.01 (±0.0004)
Linearity with EPS	mm (in)	±0.01 (±0.0004)	±0.01 (±0.0004)

Position-Time Diagram

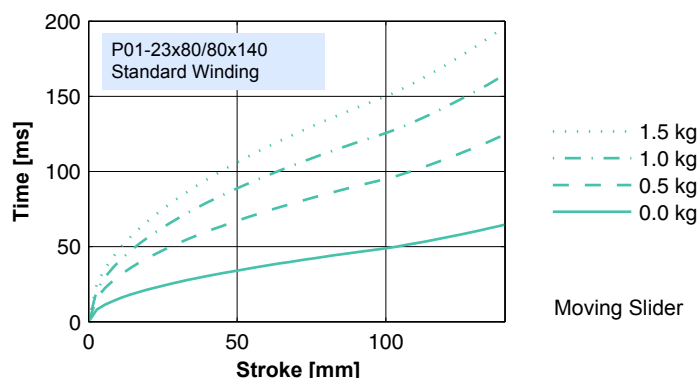

Moving Slider

Connector Type

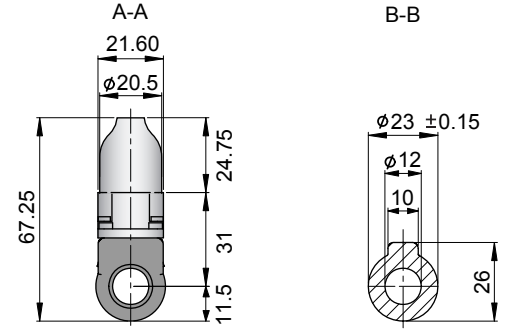
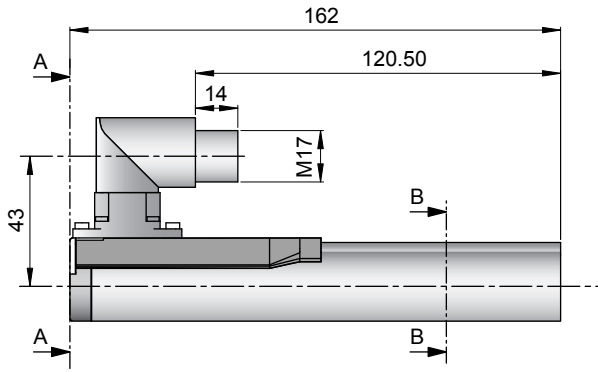

Linear Motor		Stator		Slider	
Type	Art.No	Type	Art. No.	Type	Art No.
P01-23x80/80x140-R	-->	PS01-23x80-R	0150-1233	& PL01-12x270/170	0150-1307

Cable Type

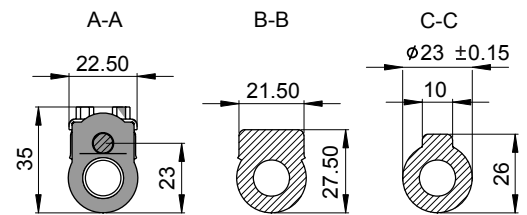
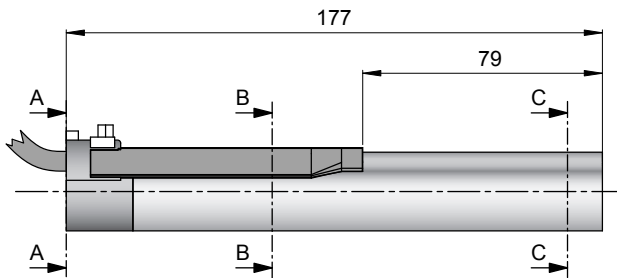

Linear Motor		Stator		Slider	
Type	Art.No	Type	Art. No.	Type	Art No.
P01-23x80/80x140-D100	-->	PS01-23x80-D100	0150-1201	& PL01-12x270/170	0150-1307
P01-23x80/80x140-R20	-->	PS01-23x80-R20	0150-1241	& PL01-12x270/170	0150-1307

Slider

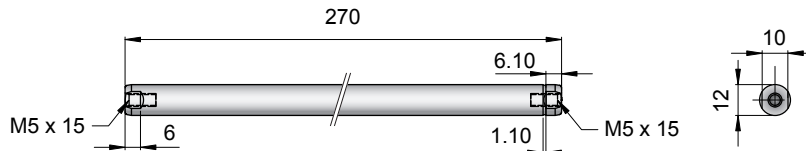

Standard Type	Slider Standard	PL01-12x270/170	0150-1307
Special Sliders	Heavy Duty Slider with WC/C-Coating	PL02-12x270/170	0150-1310
	Hollow Slider hole diameter 4.2mm	PL01-12x270/170-L	0150-1393

Connectors

Motor Connector Wiring

Cable Length:
P01-23x80/...x... 1.0m
P01-23x80/...x...-R20 0.2m

		P01-23...-R	P01-23...-R20	P01-23...-
Ph 1+	red	1	1	
Ph 1-	pink	2	6	
Ph 2+	blue	3	2	
Ph 2-	grey	4	7	
+5VDC	white	A	3	
GND	inner Shield	B	8	
Sine	yellow	C	4	
Cosine	green	D	9	
Temp.	black	E	5	
Shield	outer Shield	Case	Case	

Accessoires

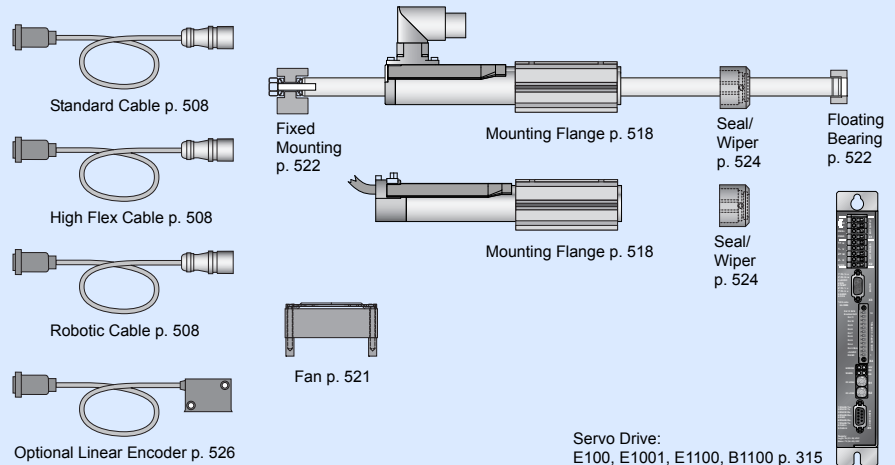

Servo Drive:
E100, E1001, E1100, B1100 p. 315

Max. Stroke: 210mm
Peak Force: 44N

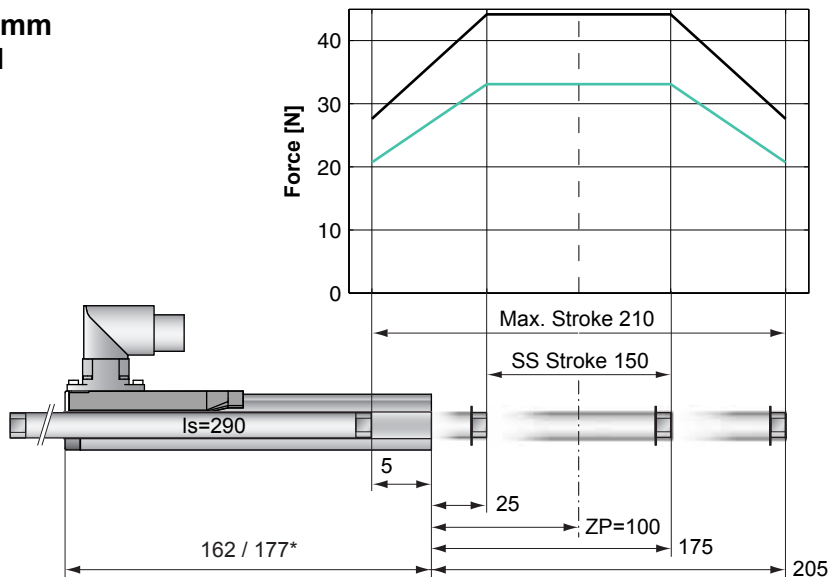

Dimensions in mm
 *Cable Type

Motor Specification

	P01-	Connector Type	Cable Type
		23x80/150x210-R	23x80/150x210-D100 23x80/150x210-R20
Extended Stroke ES	mm (in)	210 (8.27)	210 (8.27)
Standard Stroke SS	mm (in)	150 (5.91)	150 (5.91)
Peak Force E1100 / E1001	N (lbf)	44 (9.9)	44 (9.9)
Peak Force E100	N (lbf)	33 (7.4)	33 (7.4)
Cont. Force	N (lbf)	9 (2.0)	9 (2.0)
Cont. Force Fan cooling	N (lbf)	16 (3.7)	16 (3.7)
Border Force	%	63	63
Force Constant	N/A (lbf/A)	11.0 (2.48)	11.0 (2.48)
Max. Current @ 72VDC	A	4.0	4.0
Max. Current @ 48VDC	A	3.8	3.8
Max. Velocity @ 72VDC	m/s (in/s)	6.0 (236)	6.0 (236)
Max. Velocity @ 48VDC	m/s (in/s)	4.0 (157)	4.0 (157)
Phase Resist. 25/80 °C	Ohm	10.3/12.5	10.3/12.5
Phase Inductance	mH	1.4	1.4
Thermal Resistance	°K/W	7.0	7.0
Thermal Time Const.	sec	1600	1600
Stator Diameter	mm (in)	23 (0.91)	23 (0.91)
Stator Length	mm (in)	162 (6.38)	177 (6.97)
Stator Mass	g (lb)	265 (0.58)	265 (0.58)
Slider Diameter	mm (in)	12 (0.47)	12 (0.47)
Slider Length	mm (in)	290 (11.42)	290 (11.42)
Slider Mass	g (lb)	220 (0.49)	220 (0.49)
Position Repeatability	mm (in)	±0.05 (±0.0020)	±0.05 (±0.0020)
Linearity	%	±0.30	±0.30
Repeatability with EPS	mm (in)	±0.01 (±0.0004)	±0.01 (±0.0004)
Linearity with EPS	mm (in)	±0.01 (±0.0004)	±0.01 (±0.0004)

Position-Time Diagram

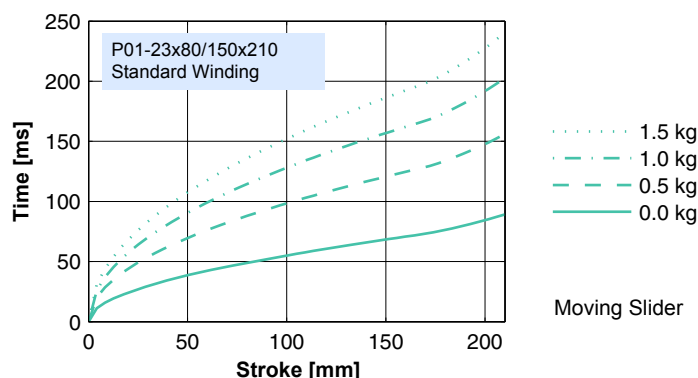

Connector Type

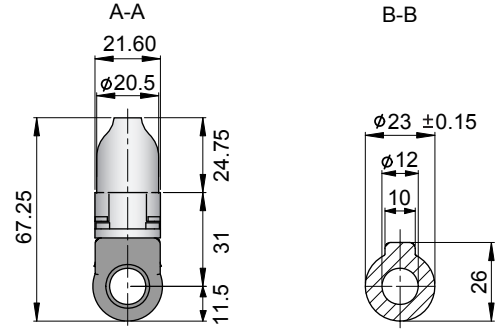
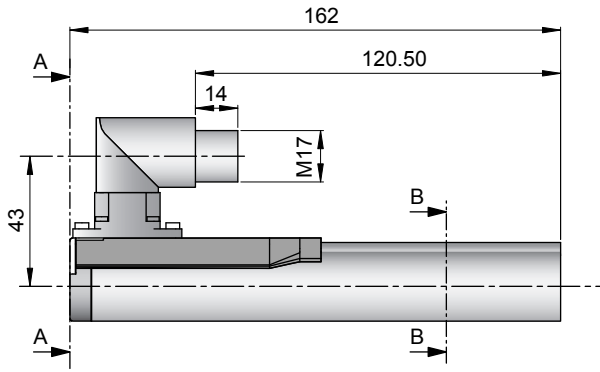

Linear Motor		Stator		Slider	
Type	Art.No	Type	Art. No.	Type	Art No.
P01-23x80/150x210-R	-->	PS01-23x80-R	0150-1233	& PL01-12x290/240	0150-1320

Cable Type

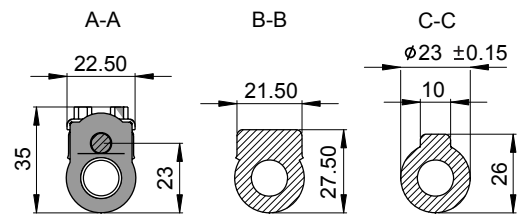
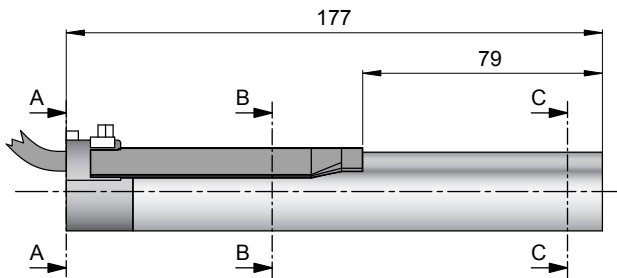

Linear Motor		Stator		Slider	
Type	Art.No	Type	Art. No.	Type	Art No.
P01-23x80/150x210-D100	-->	PS01-23x80-D100	0150-1201	& PL01-12x290/240	0150-1320
P01-23x80/150x210-R20	-->	PS01-23x80-R20	0150-1241	& PL01-12x290/240	0150-1320

Slider

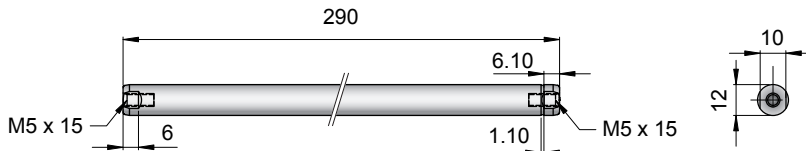

Standard Type	Slider Standard	PL01-12x290/240	0150-1320
Special Sliders	Heavy Duty Slider with WC/C-Coating	PL02-12x290/240	0150-1321
	Hollow Slider hole diameter 4.2mm	PL01-12x290/240-L	0150-1363

Connectors

Motor Connector Wiring

Cable Length:
P01-23x80/...x... 1.0m
P01-23x80/...x...-R20 0.2m

		P01-23...-R	P01-23...-R20	P01-23....
Ph 1+	red	1	1	
Ph 1-	pink	2	6	
Ph 2+	blue	3	2	
Ph 2-	grey	4	7	
+5VDC	white	A	3	
GND	inner Shield	B	8	
Sine	yellow	C	4	
Cosine	green	D	9	
Temp.	black	E	5	
Shield	outer Shield	Case	Case	

Accessoires

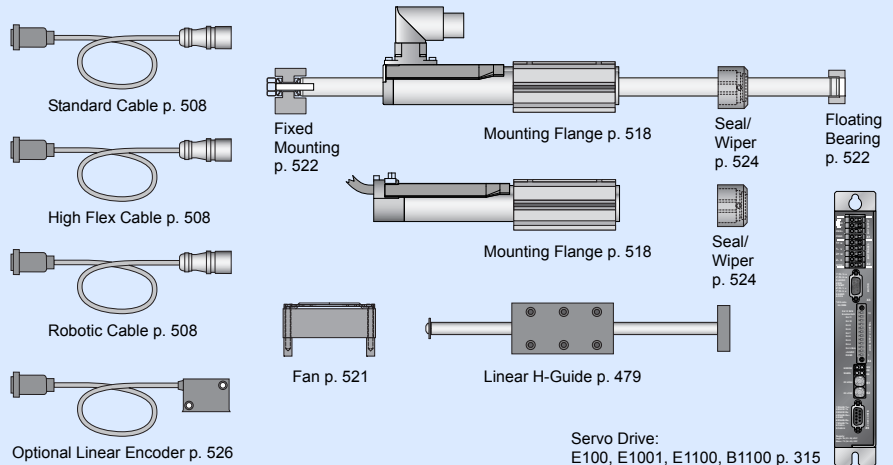

Max. Stroke: 270mm
Peak Force: 44N

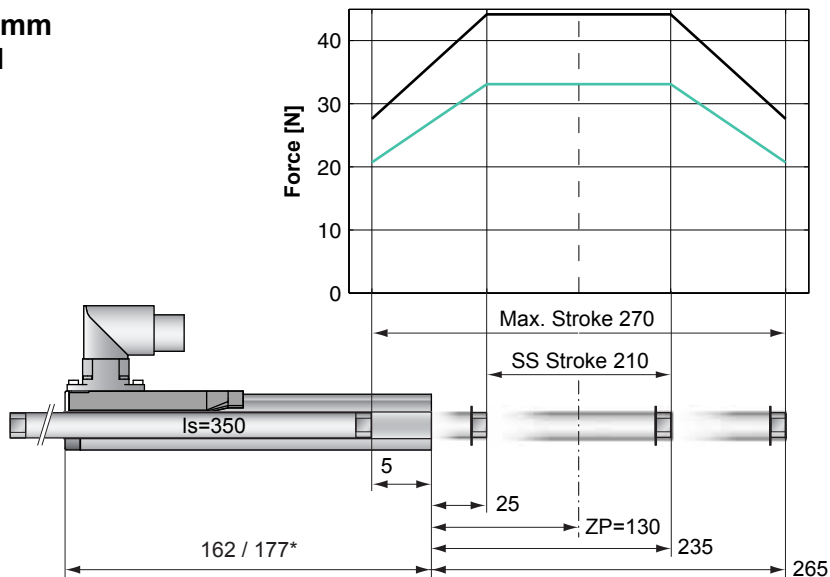

Standard Winding:
 — E1100, 72VDC & E1001, 72VDC
 — E100, 48VDC

Dimensions in mm
 *Cable Type

Motor Specification

	P01-	Connector Type	Cable Type
		23x80/210x270-R	23x80/210x270-D100 23x80/210x270-R20
Extended Stroke ES	mm (in)	270 (10.63)	270 (10.63)
Standard Stroke SS	mm (in)	210 (8.27)	210 (8.27)
Peak Force E1100 / E1001	N (lbf)	44 (9.9)	44 (9.9)
Peak Force E100	N (lbf)	33 (7.4)	33 (7.4)
Cont. Force	N (lbf)	9 (2.0)	9 (2.0)
Cont. Force Fan cooling	N (lbf)	16 (3.7)	16 (3.7)
Border Force	%	63	63
Force Constant	N/A (lbf/A)	11.0 (2.48)	11.0 (2.48)
Max. Current @ 72VDC	A	4.0	4.0
Max. Current @ 48VDC	A	3.8	3.8
Max. Velocity @ 72VDC	m/s (in/s)	6.0 (236)	6.0 (236)
Max. Velocity @ 48VDC	m/s (in/s)	4.0 (157)	4.0 (157)
Phase Resist. 25/80 °C	Ohm	10.3/12.5	10.3/12.5
Phase Inductance	mH	1.4	1.4
Thermal Resistance	°K/W	7.0	7.0
Thermal Time Const.	sec	1600	1600
Stator Diameter	mm (in)	23 (0.91)	23 (0.91)
Stator Length	mm (in)	162 (6.38)	177 (6.97)
Stator Mass	g (lb)	265 (0.58)	265 (0.58)
Slider Diameter	mm (in)	12 (0.47)	12 (0.47)
Slider Length	mm (in)	350 (13.78)	350 (13.78)
Slider Mass	g (lb)	271 (0.60)	271 (0.60)
Position Repeatability	mm (in)	±0.05 (±0.0020)	±0.05 (±0.0020)
Linearity	%	±0.25	±0.25
Repeatability with EPS	mm (in)	±0.01 (±0.0004)	±0.01 (±0.0004)
Linearity with EPS	mm (in)	±0.01 (±0.0004)	±0.01 (±0.0004)

Position-Time Diagram

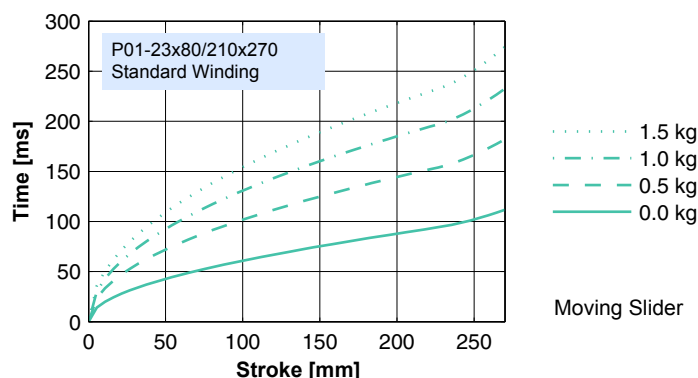

Moving Slider

Connector Type

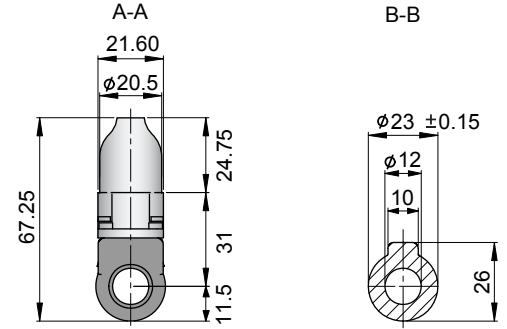
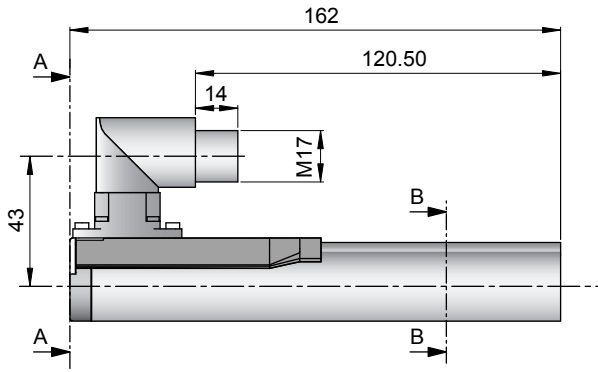

Linear Motor		Stator		Slider	
Type	Art.No	Type	Art. No.	Type	Art No.
P01-23x80/210x270-R	-->	PS01-23x80-R	0150-1233	& PL01-12x350/300	0150-1322

Cable Type

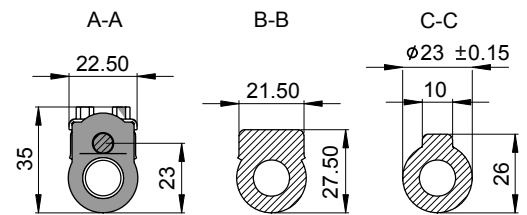
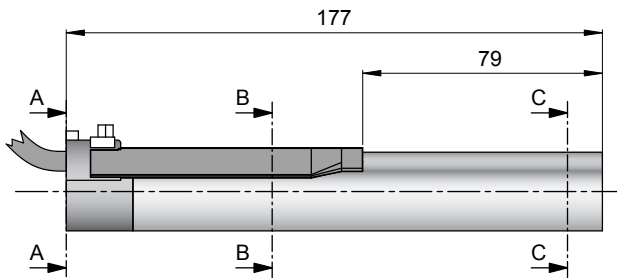

Linear Motor		Stator		Slider	
Type	Art.No	Type	Art. No.	Type	Art No.
P01-23x80/210x270-D100	-->	PS01-23x80-D100	0150-1201	& PL01-12x350/300	0150-1322
P01-23x80/210x270-R20	-->	PS01-23x80-R20	0150-1241	& PL01-12x350/300	0150-1322

Slider

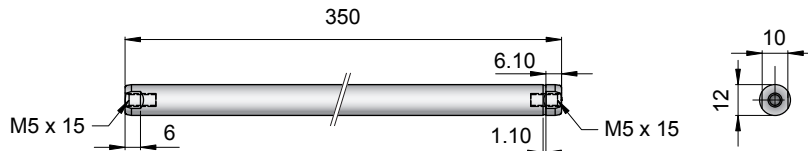

Standard Type	Slider Standard	PL01-12x350/300	0150-1322
Special Sliders	Heavy Duty Slider with WC/C-Coating	PL02-12x350/300	0150-1323
	Hollow Slider hole diameter 4.2mm	PL01-12x350/300-L	0150-1479

Connectors

Motor Connector Wiring

Cable Length:
P01-23x80/...x... 1.0m
P01-23x80/...x...-R20 0.2m

		P01-23...-R	P01-23...-R20	P01-23...-
Ph 1+	red	1	1	
Ph 1-	pink	2	6	
Ph 2+	blue	3	2	
Ph 2-	grey	4	7	
+5VDC	white	A	3	
GND	inner Shield	B	8	
Sine	yellow	C	4	
Cosine	green	D	9	
Temp.	black	E	5	
Shield	outer Shield	Case	Case	

Accessoires

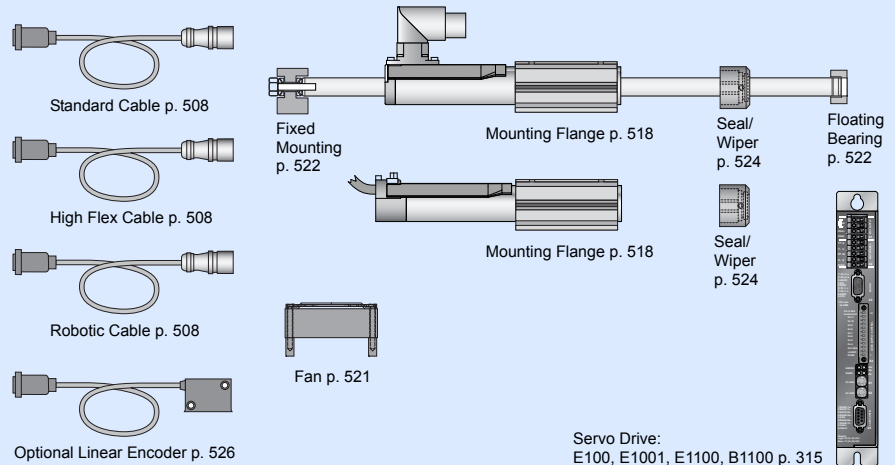

Max. Stroke: 340mm
Peak Force: 44N

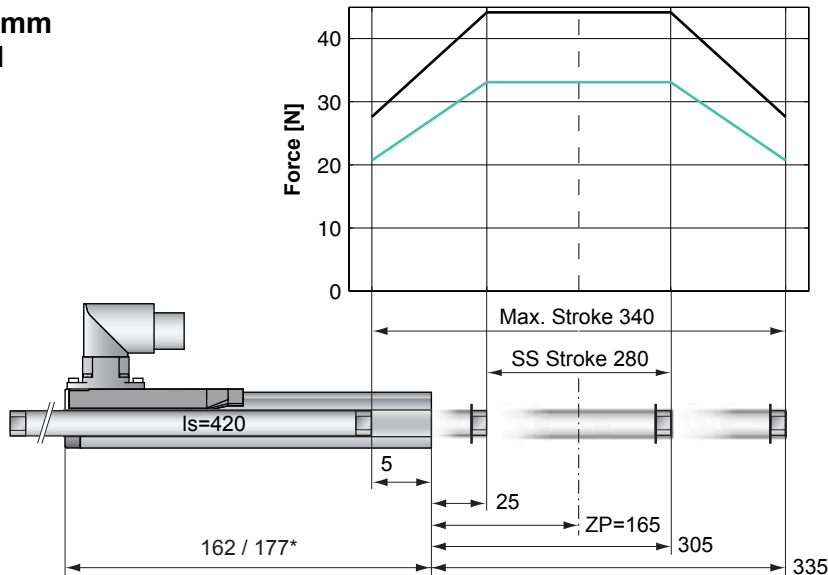

Standard Winding:
 — E1100, 72VDC & E1001, 72VDC
 — E100, 48VDC

Dimensions in mm
 *Cable Type

Motor Specification

	P01-	Connector Type	Cable Type
		23x80/280x340-R	23x80/280x340-D100 23x80/280x340-R20
Extended Stroke ES	mm (in)	340 (13.39)	340 (13.39)
Standard Stroke SS	mm (in)	280 (11.02)	280 (11.02)
Peak Force E1100 / E1001	N (lbf)	44 (9.9)	44 (9.9)
Peak Force E100	N (lbf)	33 (7.4)	33 (7.4)
Cont. Force	N (lbf)	9 (2.0)	9 (2.0)
Cont. Force Fan cooling	N (lbf)	16 (3.7)	16 (3.7)
Border Force	%	63	63
Force Constant	N/A (lbf/A)	11.0 (2.48)	11.0 (2.48)
Max. Current @ 72VDC	A	4.0	4.0
Max. Current @ 48VDC	A	3.8	3.8
Max. Velocity @ 72VDC	m/s (in/s)	6.0 (236)	6.0 (236)
Max. Velocity @ 48VDC	m/s (in/s)	4.0 (157)	4.0 (157)
Phase Resist. 25/80 °C	Ohm	10.3/12.5	10.3/12.5
Phase Inductance	mH	1.4	1.4
Thermal Resistance	°K/W	7.0	7.0
Thermal Time Const.	sec	1600	1600
Stator Diameter	mm (in)	23 (0.91)	23 (0.91)
Stator Length	mm (in)	162 (6.38)	177 (6.97)
Stator Mass	g (lb)	265 (0.58)	265 (0.58)
Slider Diameter	mm (in)	12 (0.47)	12 (0.47)
Slider Length	mm (in)	420 (16.54)	420 (16.54)
Slider Mass	g (lb)	330 (0.73)	330 (0.73)
Position Repeatability	mm (in)	±0.05 (±0.0020)	±0.05 (±0.0020)
Linearity	%	±0.25	±0.25
Repeatability with EPS	mm (in)	±0.01 (±0.0004)	±0.01 (±0.0004)
Linearity with EPS	mm (in)	±0.01 (±0.0004)	±0.01 (±0.0004)

Position-Time Diagram

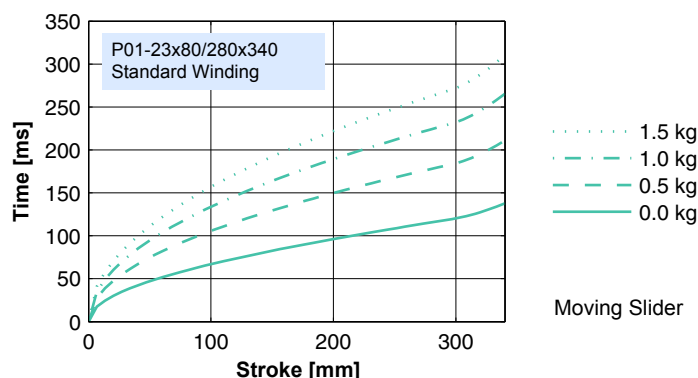

Moving Slider

Connector Type

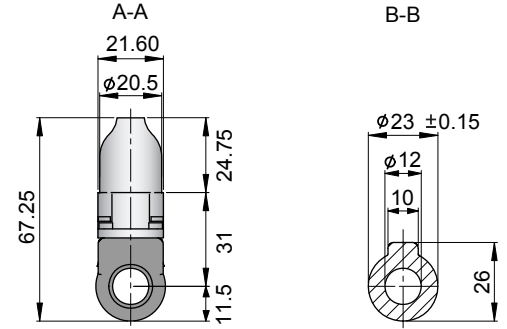
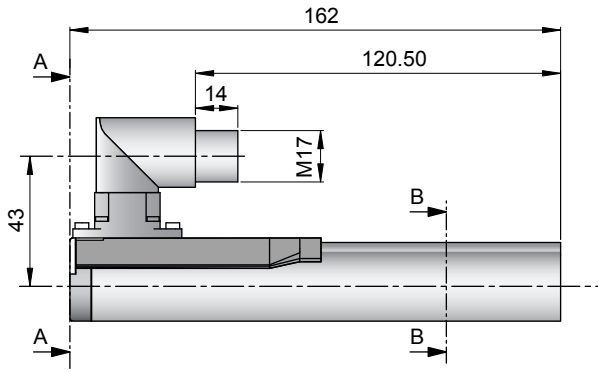

Linear Motor		Stator		Slider	
Type	Art.No	Type	Art. No.	Type	Art No.
P01-23x80/280x340-R	-->	PS01-23x80-R	0150-1233	& PL01-12x420/370	0150-1324

Cable Type

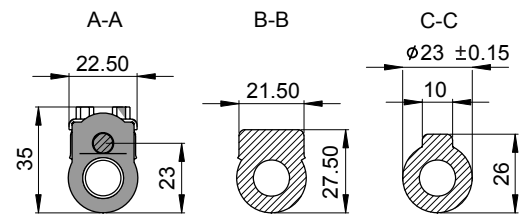
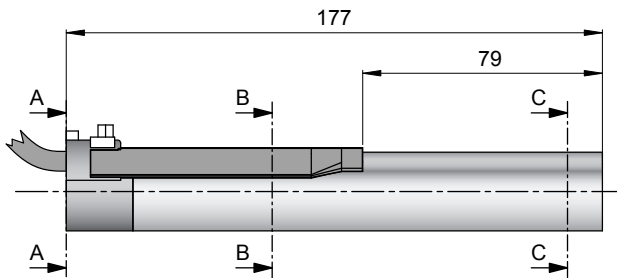

Linear Motor		Stator		Slider	
Type	Art.No	Type	Art. No.	Type	Art No.
P01-23x80/280x340-D100	-->	PS01-23x80-D100	0150-1201	& PL01-12x420/370	0150-1324
P01-23x80/280x340-R20	-->	PS01-23x80-R20	0150-1241	& PL01-12x420/370	0150-1324

Slider

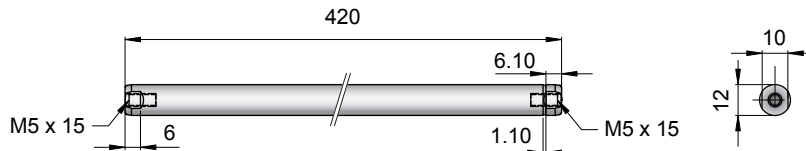

Standard Type	Slider Standard	PL01-12x420/370	0150-1324
Special Sliders	Heavy Duty Slider with WC/C-Coating	PL02-12x420/370	0150-1325
	Hollow Slider hole diameter 4.2mm	PL01-12x420/370-L	0150-1394

Connectors

Motor Connector Wiring

Cable Length:
P01-23x80/...x... 1.0m
P01-23x80/...x...-R20 0.2m

		P01-23...-R	P01-23...-R20	P01-23...-
Ph 1+	red	1	1	
Ph 1-	pink	2	6	
Ph 2+	blue	3	2	
Ph 2-	grey	4	7	
+5VDC	white	A	3	
GND	inner Shield	B	8	
Sine	yellow	C	4	
Cosine	green	D	9	
Temp.	black	E	5	
Shield	outer Shield	Case	Case	

Accessoires

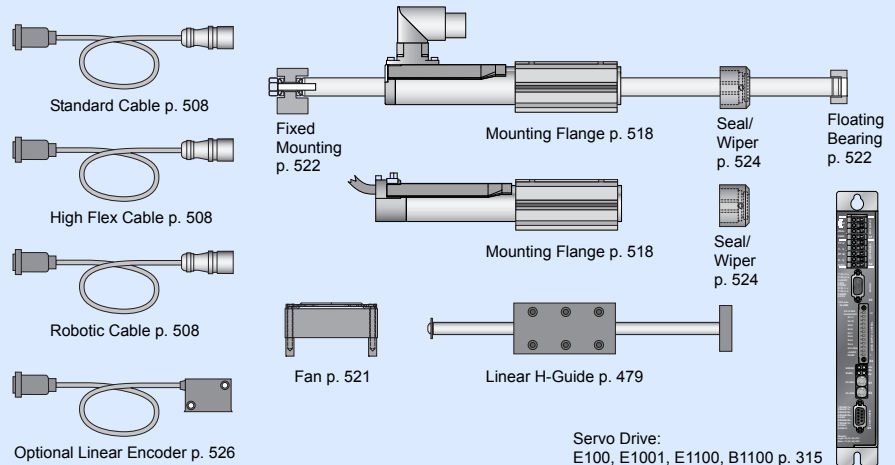

Max. Stroke: 400mm
Peak Force: 44N

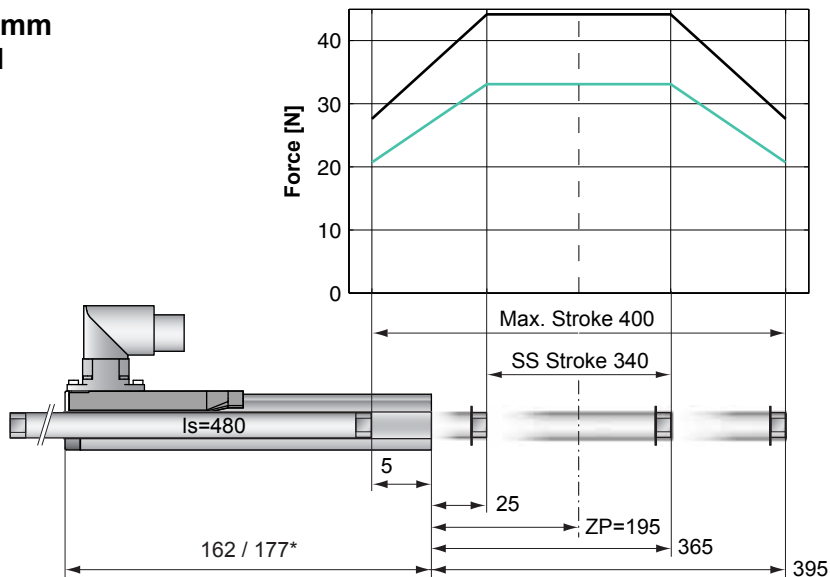

Standard Winding:

- E1100, 72VDC & E1001, 72VDC
- E100, 48VDC

Dimensions in mm
 *Cable Type

Motor Specification

	P01-	Connector Type	Cable Type
		23x80/340x400-R	23x80/340x400-D100 23x80/340x400-R20
Extended Stroke ES	mm (in)	400 (15.75)	400 (15.75)
Standard Stroke SS	mm (in)	340 (13.39)	340 (13.39)
Peak Force E1100 / E1001	N (lbf)	44 (9.9)	44 (9.9)
Peak Force E100	N (lbf)	33 (7.4)	33 (7.4)
Cont. Force	N (lbf)	9 (2.0)	9 (2.0)
Cont. Force Fan cooling	N (lbf)	16 (3.7)	16 (3.7)
Border Force	%	63	63
Force Constant	N/A (lbf/A)	11.0 (2.48)	11.0 (2.48)
Max. Current @ 72VDC	A	4.0	4.0
Max. Current @ 48VDC	A	3.8	3.8
Max. Velocity @ 72VDC	m/s (in/s)	6.0 (236)	6.0 (236)
Max. Velocity @ 48VDC	m/s (in/s)	4.0 (157)	4.0 (157)
Phase Resist. 25/80 °C	Ohm	10.3/12.5	10.3/12.5
Phase Inductance	mH	1.4	1.4
Thermal Resistance	°K/W	7.0	7.0
Thermal Time Const.	sec	1600	1600
Stator Diameter	mm (in)	23 (0.91)	23 (0.91)
Stator Length	mm (in)	162 (6.38)	177 (6.97)
Stator Mass	g (lb)	265 (0.58)	265 (0.58)
Slider Diameter	mm (in)	12 (0.47)	12 (0.47)
Slider Length	mm (in)	480 (18.90)	480 (18.90)
Slider Mass	g (lb)	380 (0.84)	380 (0.84)
Position Repeatability	mm (in)	±0.05 (±0.0020)	±0.05 (±0.0020)
Linearity	%	±0.25	±0.25
Repeatability with EPS	mm (in)	±0.01 (±0.0004)	±0.01 (±0.0004)
Linearity with EPS	mm (in)	±0.01 (±0.0004)	±0.01 (±0.0004)

Position-Time Diagram

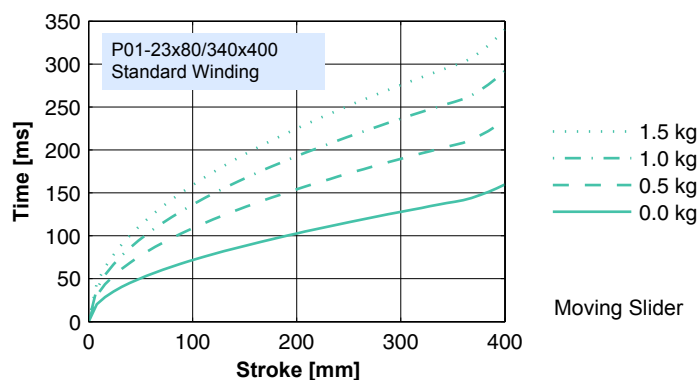

Connector Type

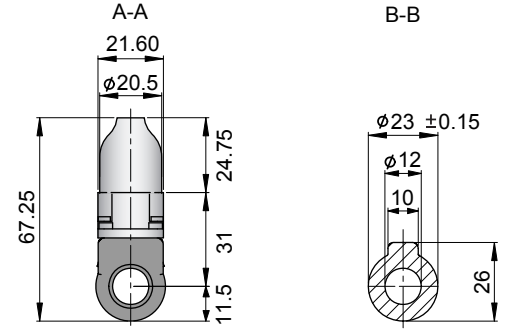
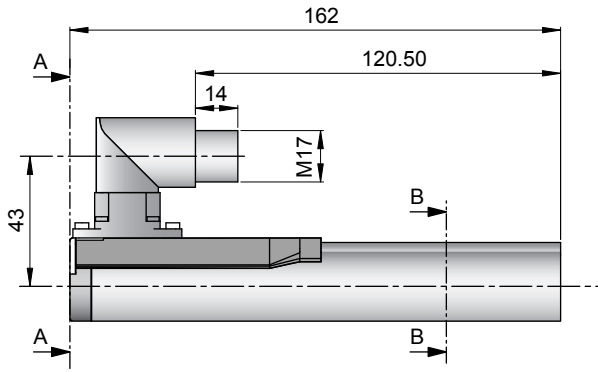

Linear Motor		Stator		Slider	
Type	Art.No	Type	Art. No.	Type	Art No.
P01-23x80/340x400-R	-->	PS01-23x80-R	0150-1233	& PL01-12x480/430	0150-1372

Cable Type

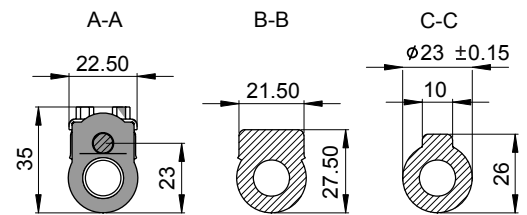
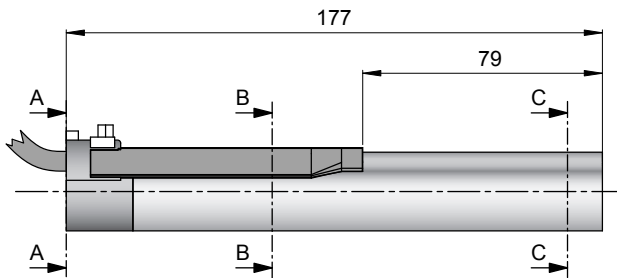

Linear Motor		Stator		Slider	
Type	Art.No	Type	Art. No.	Type	Art No.
P01-23x80/340x400-D100	-->	PS01-23x80-D100	0150-1201	& PL01-12x480/430	0150-1372
P01-23x80/340x400-R20	-->	PS01-23x80-R20	0150-1241	& PL01-12x480/430	0150-1372

Slider

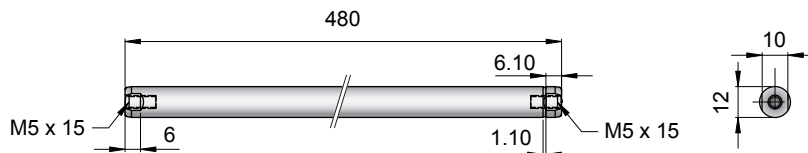

Standard Type	Slider Standard	PL01-12x480/430	0150-1372
Special Sliders	Heavy Duty Slider with WC/C-Coating	PL02-12x480/430	0150-1373
	Hollow Slider hole diameter 4.2mm	PL01-12x480/430-L	on request

Connectors

Motor Connector Wiring

Cable Length:
P01-23x80/... 1.0m
P01-23x80/...-R20 0.2m

		P01-23...-R	P01-23...-R20	P01-23....
Ph 1+	red	1	1	
Ph 1-	pink	2	6	
Ph 2+	blue	3	2	
Ph 2-	grey	4	7	
+5VDC	white	A	3	
GND	inner Shield	B	8	
Sine	yellow	C	4	
Cosine	green	D	9	
Temp.	black	E	5	
Shield	outer Shield	Case	Case	

Accessoires

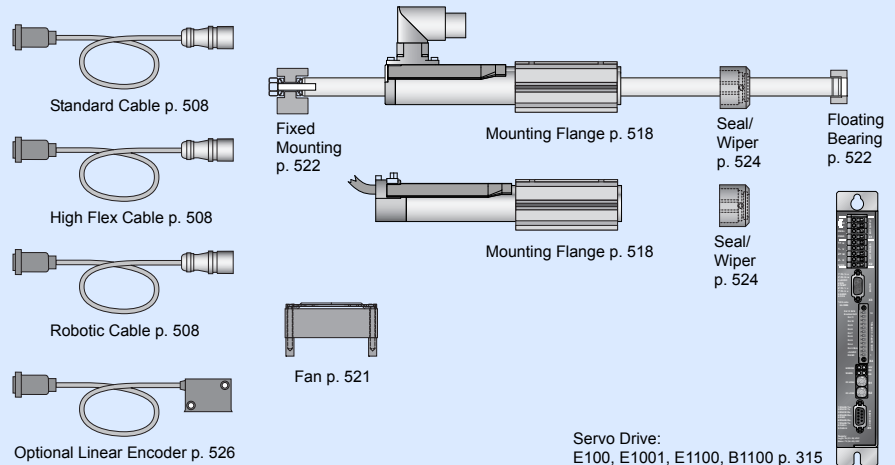

Servo Drive:
E100, E1001, E1100, B1100 p. 315

Max. Stroke: 500mm
Peak Force: 44N

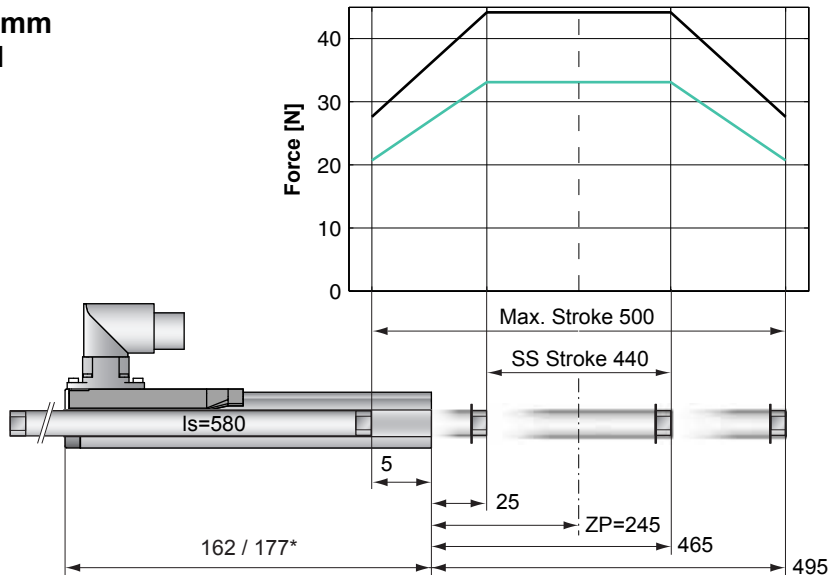

Standard Winding:
 — E1100, 72VDC & E1001, 72VDC
 — E100, 48VDC

Dimensions in mm
 *Cable Type

Motor Specification

	P01-	Connector Type	Cable Type
		23x80/440x500-R	23x80/440x500-D100 23x80/440x500-R20
Extended Stroke ES	mm (in)	500 (19.69)	500 (19.69)
Standard Stroke SS	mm (in)	440 (17.32)	440 (17.32)
Peak Force E1100 / E1001	N (lbf)	44 (9.9)	44 (9.9)
Peak Force E100	N (lbf)	33 (7.4)	33 (7.4)
Cont. Force	N (lbf)	9 (2.0)	9 (2.0)
Cont. Force Fan cooling	N (lbf)	16 (3.7)	16 (3.7)
Border Force	%	63	63
Force Constant	N/A (lbf/A)	11.0 (2.48)	11.0 (2.48)
Max. Current @ 72VDC	A	4.0	4.0
Max. Current @ 48VDC	A	3.8	3.8
Max. Velocity @ 72VDC	m/s (in/s)	6.0 (236)	6.0 (236)
Max. Velocity @ 48VDC	m/s (in/s)	4.0 (157)	4.0 (157)
Phase Resist. 25/80 °C	Ohm	10.3/12.5	10.3/12.5
Phase Inductance	mH	1.4	1.4
Thermal Resistance	°K/W	7.0	7.0
Thermal Time Const.	sec	1600	1600
Stator Diameter	mm (in)	23 (0.91)	23 (0.91)
Stator Length	mm (in)	162 (6.38)	177 (6.97)
Stator Mass	g (lb)	265 (0.58)	265 (0.58)
Slider Diameter	mm (in)	12 (0.47)	12 (0.47)
Slider Length	mm (in)	580 (22.83)	580 (22.83)
Slider Mass	g (lb)	465 (1.03)	465 (1.03)
Position Repeatability	mm (in)	±0.05 (±0.0020)	±0.05 (±0.0020)
Linearity	%	±0.20	±0.20
Repeatability with EPS	mm (in)	±0.01 (±0.0004)	±0.01 (±0.0004)
Linearity with EPS	mm (in)	±0.01 (±0.0004)	±0.01 (±0.0004)

Position-Time Diagram

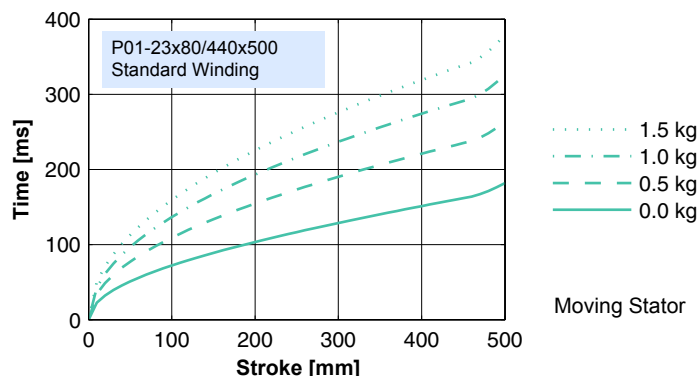

Moving Stator

Connector Type

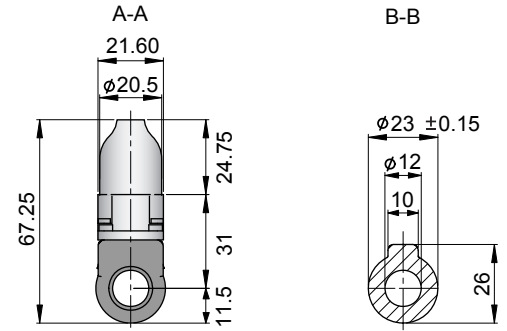
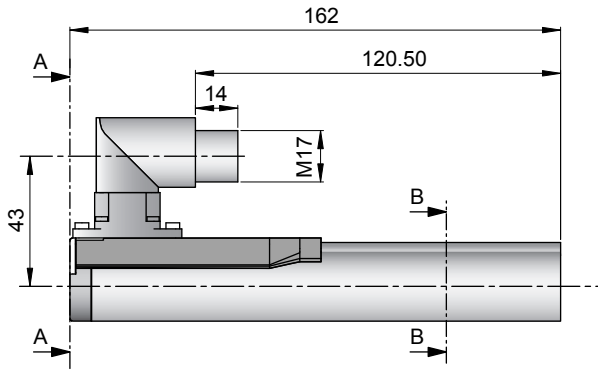

Linear Motor		Stator		Slider	
Type	Art.No	Type	Art. No.	Type	Art No.
P01-23x80/440x500-R	-->	PS01-23x80-R	0150-1233	& PL01-12x580/530	0150-1355

Cable Type

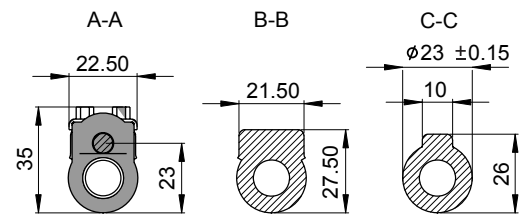
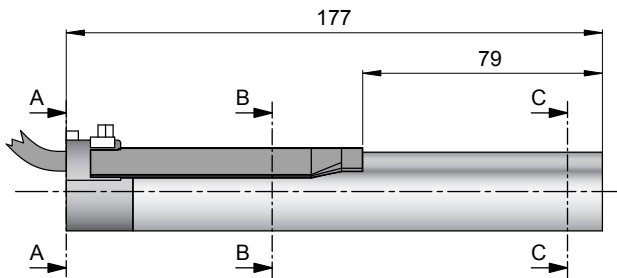

Linear Motor		Stator		Slider	
Type	Art.No	Type	Art. No.	Type	Art No.
P01-23x80/440x500-D100	-->	PS01-23x80-D100	0150-1201	& PL01-12x580/530	0150-1355
P01-23x80/440x500-R20	-->	PS01-23x80-R20	0150-1241	& PL01-12x580/530	0150-1355

Slider

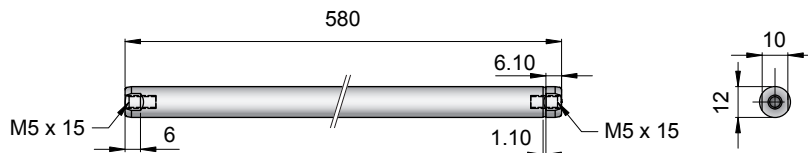

Standard Type	Slider Standard	PL01-12x580/530	0150-1355
Special Sliders	Heavy Duty Slider with WC/C-Coating	PL02-12x580/530	0150-1356
	Hollow Slider hole diameter 4.2mm	PL01-12x580/530-L	0150-1391

Connectors

Motor Connector Wiring

Cable Length:
P01-23x80/...x... 1.0m
P01-23x80/...x...-R20 0.2m

		P01-23...-R	P01-23...-R20
Ph 1+	red	1	1
Ph 1-	pink	2	6
Ph 2+	blue	3	2
Ph 2-	grey	4	7
+5VDC	white	A	3
GND	inner Shield	B	8
Sine	yellow	C	4
Cosine	green	D	9
Temp.	black	E	5
Shield	outer Shield	Case	Case

Accessoires

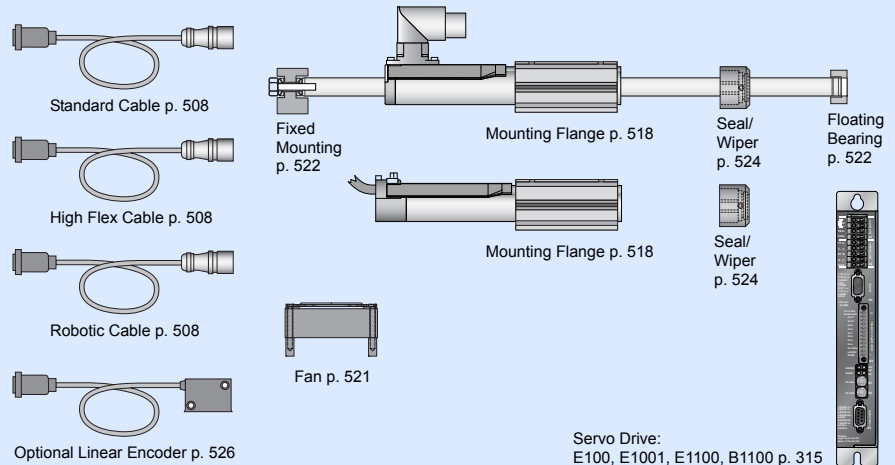

Max. Stroke: 680mm
Peak Force: 44N

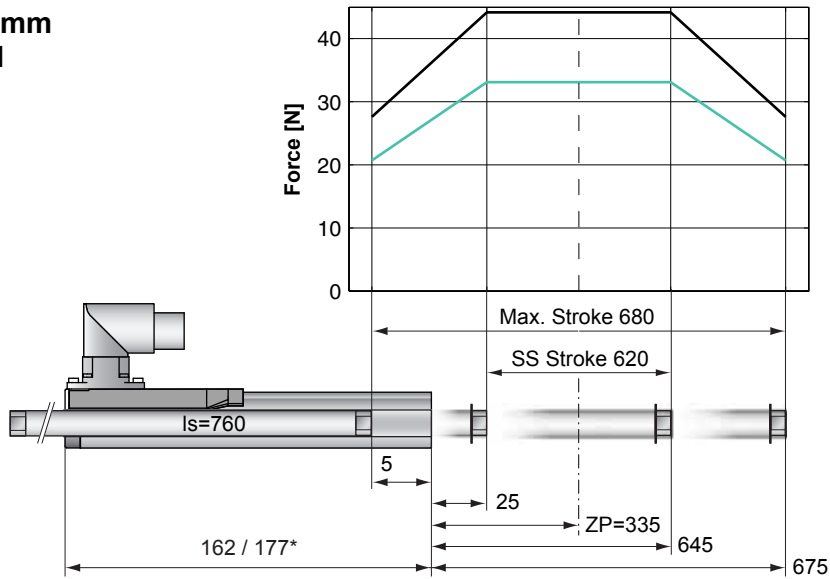

Standard Winding:
 — E1100, 72VDC & E1001, 72VDC
 — E100, 48VDC

Dimensions in mm
 *Cable Type

Motor Specification

	P01-	Connector Type	Cable Type
		23x80/620x680-R	23x80/620x680-D100 23x80/620x680-R20
Extended Stroke ES	mm (in)	680 (26.77)	680 (26.77)
Standard Stroke SS	mm (in)	620 (24.41)	620 (24.41)
Peak Force E1100 / E1001	N (lbf)	44 (9.9)	44 (9.9)
Peak Force E100	N (lbf)	33 (7.4)	33 (7.4)
Cont. Force	N (lbf)	9 (2.0)	9 (2.0)
Cont. Force Fan cooling	N (lbf)	16 (3.7)	16 (3.7)
Border Force	%	63	63
Force Constant	N/A (lbf/A)	11.0 (2.48)	11.0 (2.48)
Max. Current @ 72VDC	A	4.0	4.0
Max. Current @ 48VDC	A	3.8	3.8
Max. Velocity @ 72VDC	m/s (in/s)	6.0 (236)	6.0 (236)
Max. Velocity @ 48VDC	m/s (in/s)	4.0 (157)	4.0 (157)
Phase Resist. 25/80 °C	Ohm	10.3/12.5	10.3/12.5
Phase Inductance	mH	1.4	1.4
Thermal Resistance	°K/W	7.0	7.0
Thermal Time Const.	sec	1600	1600
Stator Diameter	mm (in)	23 (0.91)	23 (0.91)
Stator Length	mm (in)	162 (6.38)	177 (6.97)
Stator Mass	g (lb)	265 (0.58)	265 (0.58)
Slider Diameter	mm (in)	12 (0.47)	12 (0.47)
Slider Length	mm (in)	760 (29.92)	760 (29.92)
Slider Mass	g (lb)	615 (1.36)	615 (1.36)
Position Repeatability	mm (in)	±0.05 (±0.0020)	±0.05 (±0.0020)
Linearity	%	±0.20	±0.20
Repeatability with EPS	mm (in)	±0.01 (±0.0004)	±0.01 (±0.0004)
Linearity with EPS	mm (in)	±0.01 (±0.0004)	±0.01 (±0.0004)

Position-Time Diagram

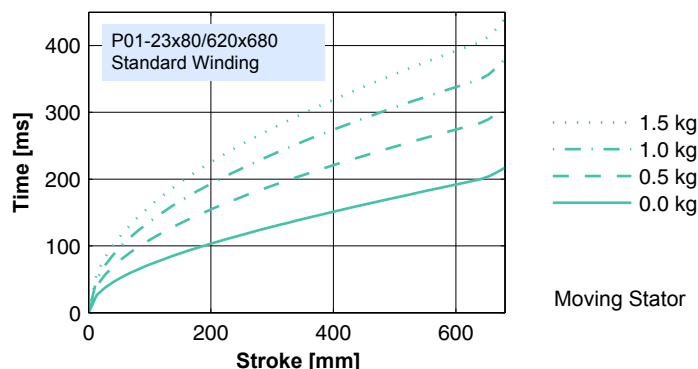

Connector Type

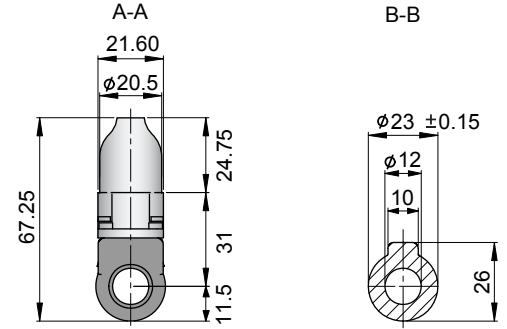
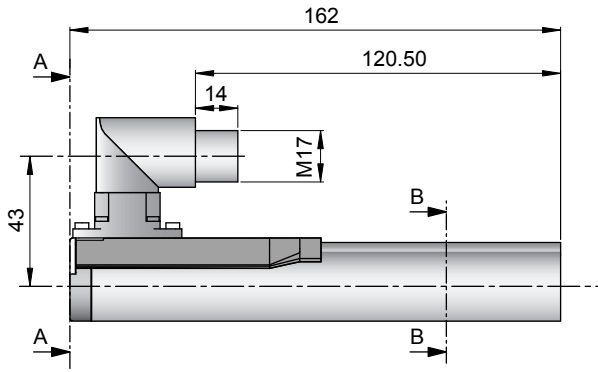

Linear Motor		Stator		Slider	
Type	Art.No	Type	Art. No.	Type	Art No.
P01-23x80/620x680-R	-->	PS01-23x80-R	0150-1233	& PL01-12x760/710	0150-1366

Cable Type

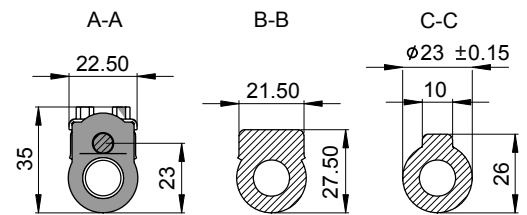
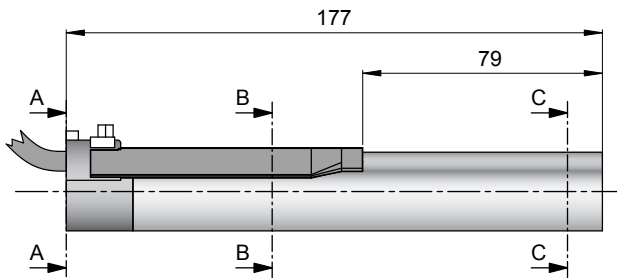

Linear Motor		Stator		Slider	
Type	Art.No	Type	Art. No.	Type	Art No.
P01-23x80/620x680-D100	-->	PS01-23x80-D100	0150-1201	& PL01-12x760/710	0150-1366
P01-23x80/620x680-R20	-->	PS01-23x80-R20	0150-1241	& PL01-12x760/710	0150-1366

Slider

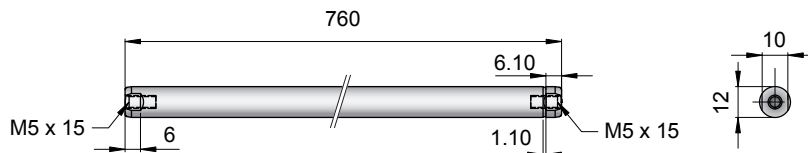

Standard Type	Slider Standard	PL01-12x760/710	0150-1366
Special Sliders	Heavy Duty Slider with WC/C-Coating	PL02-12x760/710	on request
	Hollow Slider hole diameter 4.2mm	PL01-12x760/710-L	0150-1392

Connectors

Motor Connector Wiring

Cable Length:
P01-23x80/...x... 1.0m
P01-23x80/...x...-R20 0.2m

		P01-23...-R	P01-23...-R20	P01-23....
Ph 1+	red	1	1	
Ph 1-	pink	2	6	
Ph 2+	blue	3	2	
Ph 2-	grey	4	7	
+5VDC	white	A	3	
GND	inner Shield	B	8	
Sine	yellow	C	4	
Cosine	green	D	9	
Temp.	black	E	5	
Shield	outer Shield	Case	Case	

Accessoires

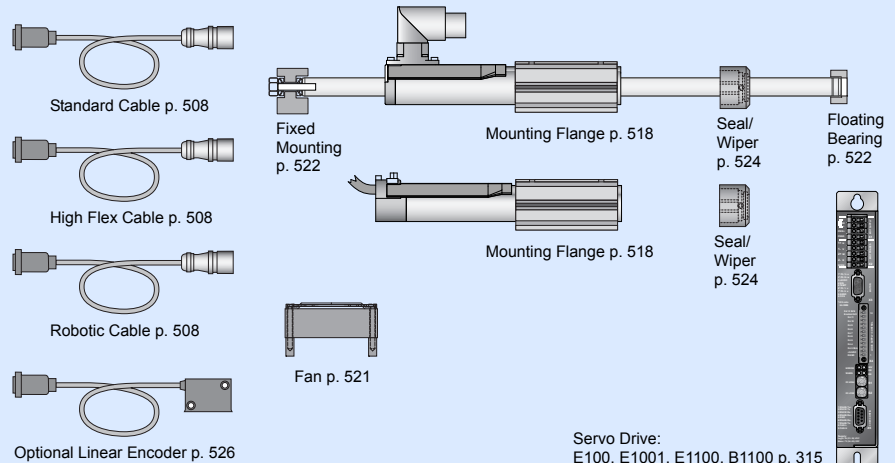

Servo Drive:
E100, E1001, E1100, B1100 p. 315

Max. Stroke: 770mm
Peak Force: 44N

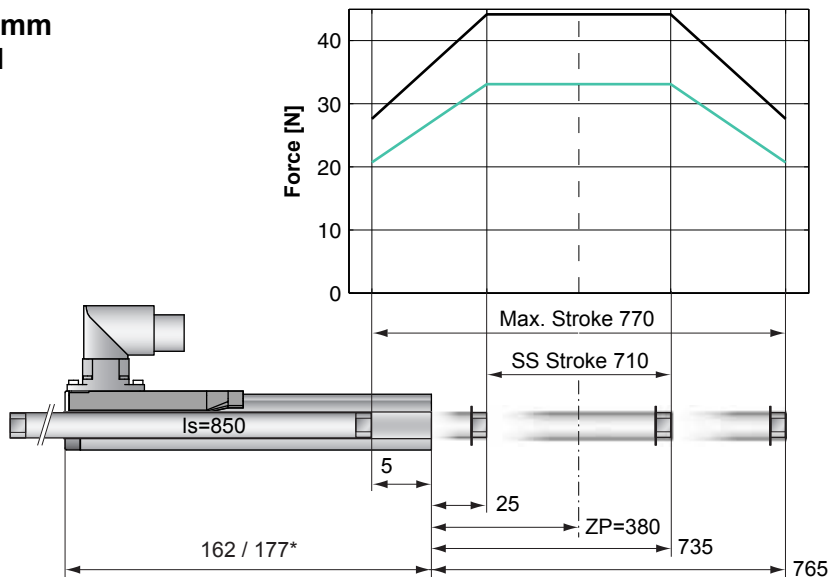

Standard Winding:
 — E1100, 72VDC & E1001, 72VDC
 — E100, 48VDC

Dimensions in mm
 *Cable Type

Motor Specification

P01-		Connector Type	Cable Type
		23x80/710x770-R	23x80/710x770-D100 23x80/710x770-R20
Extended Stroke ES	mm (in)	770 (30.31)	770 (30.31)
Standard Stroke ES	mm (in)	710 (27.95)	710 (27.95)
Peak Force E1100 / E1001	N (lbf)	44 (9.9)	44 (9.9)
Peak Force E100	N (lbf)	33 (7.4)	33 (7.4)
Cont. Force	N (lbf)	9 (2.0)	9 (2.0)
Cont. Force Fan cooling	N (lbf)	16 (3.7)	16 (3.7)
Border Force	%	63	63
Force Constant	N/A (lbf/A)	11.0 (2.48)	11.0 (2.48)
Max. Current @ 72VDC	A	4.0	4.0
Max. Current @ 48VDC	A	3.8	3.8
Max. Velocity @ 72VDC	m/s (in/s)	6.0 (236)	6.0 (236)
Max. Velocity @ 48VDC	m/s (in/s)	4.0 (157)	4.0 (157)
Phase Resist. 25/80 °C	Ohm	10.3/12.5	10.3/12.5
Phase Inductance	mH	1.4	1.4
Thermal Resistance	°K/W	7.0	7.0
Thermal Time Const.	sec	1600	1600
Stator Diameter	mm (in)	23 (0.91)	23 (0.91)
Stator Length	mm (in)	162 (6.38)	177 (6.97)
Stator Mass	g (lb)	265 (0.58)	265 (0.58)
Slider Diameter	mm (in)	12 (0.47)	12 (0.47)
Slider Length	mm (in)	850 (33.46)	850 (33.46)
Slider Mass	g (lb)	690 (1.52)	690 (1.52)
Position Repeatability	mm (in)	±0.05 (±0.0020)	±0.05 (±0.0020)
Linearity	%	±0.20	±0.20
Repeatability with EPS	mm (in)	±0.01 (±0.0004)	±0.01 (±0.0004)
Linearity with EPS	mm (in)	±0.01 (±0.0004)	±0.01 (±0.0004)

Position-Time Diagram

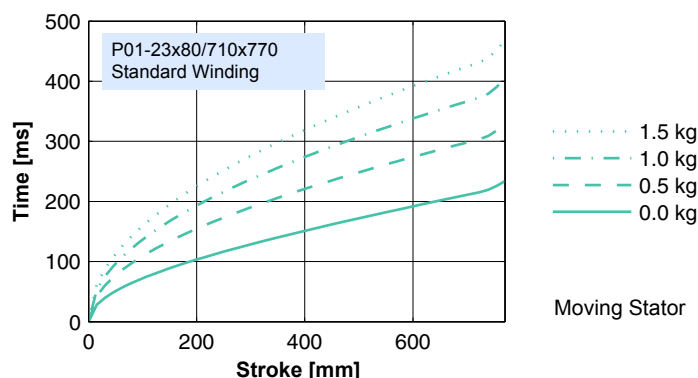

Connector Type

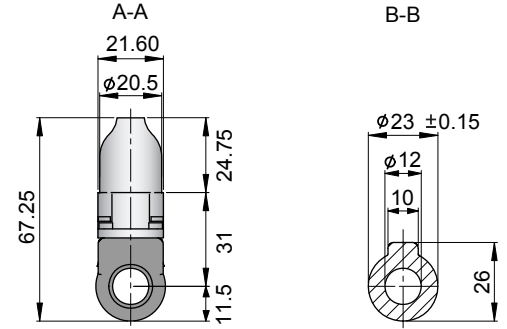
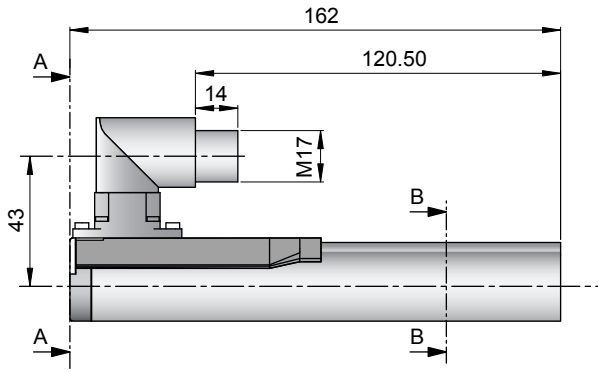

Linear Motor		Stator		Slider	
Type	Art.No	Type	Art. No.	Type	Art No.
P01-23x80/710x770-R	-->	PS01-23x80-R	0150-1233	& PL01-12x850/800	0150-1365

Cable Type

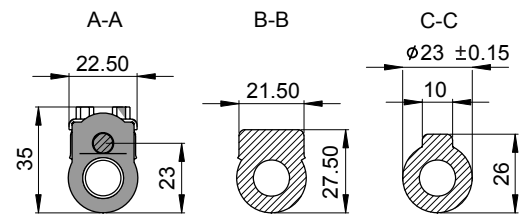
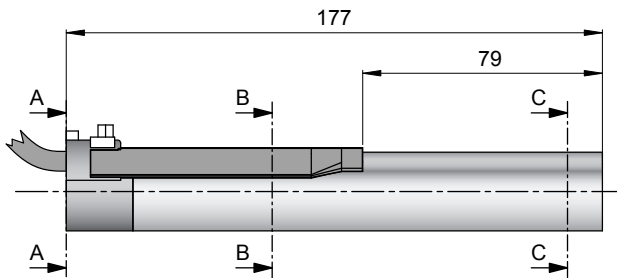

Linear Motor		Stator		Slider	
Type	Art.No	Type	Art. No.	Type	Art No.
P01-23x80/710x770-D100	-->	PS01-23x80-D100	0150-1201	& PL01-12x850/800	0150-1365
P01-23x80/710x770-R20	-->	PS01-23x80-R20	0150-1241	& PL01-12x850/800	0150-1365

Slider

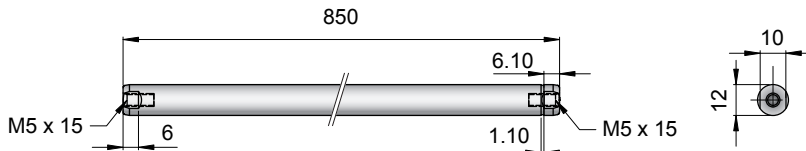

Standard Type	Slider Standard	PL01-12x850/800	0150-1365
Special Sliders	Heavy Duty Slider with WC/C-Coating	PL02-12x850/800	on request
	Hollow Slider hole diameter 4.2mm	PL01-12x850/800-L	on request

Connectors

Motor Connector Wiring

Cable Length:
P01-23x80/...x... 1.0m
P01-23x80/...x...-R20 0.2m

		P01-23...-R	P01-23...-R20	P01-23...-
Ph 1+	red	1	1	
Ph 1-	pink	2	6	
Ph 2+	blue	3	2	
Ph 2-	grey	4	7	
+5VDC	white	A	3	
GND	inner Shield	B	8	
Sine	yellow	C	4	
Cosine	green	D	9	
Temp.	black	E	5	
Shield	outer Shield	Case	Case	

Accessoires

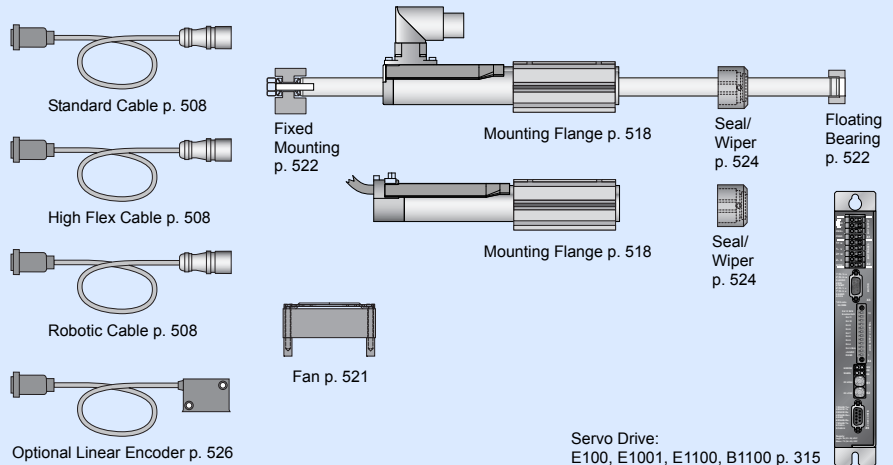

Servo Drive:
E100, E1001, E1100, B1100 p. 315



P01-23x160/70x70 64

P01-23x160/40x100 66

P01-23x160/0x140 68

P01-23x160/70x210 70

P01-23x160/130x270 72

P01-23x160/200x340 74

P01-23x160/260x400 76

P01-23x160/360x500 78

P01-23x160/540x680 80

P01-23x160/630x770 82

Max. Stroke: 70mm
Peak Force: 49N

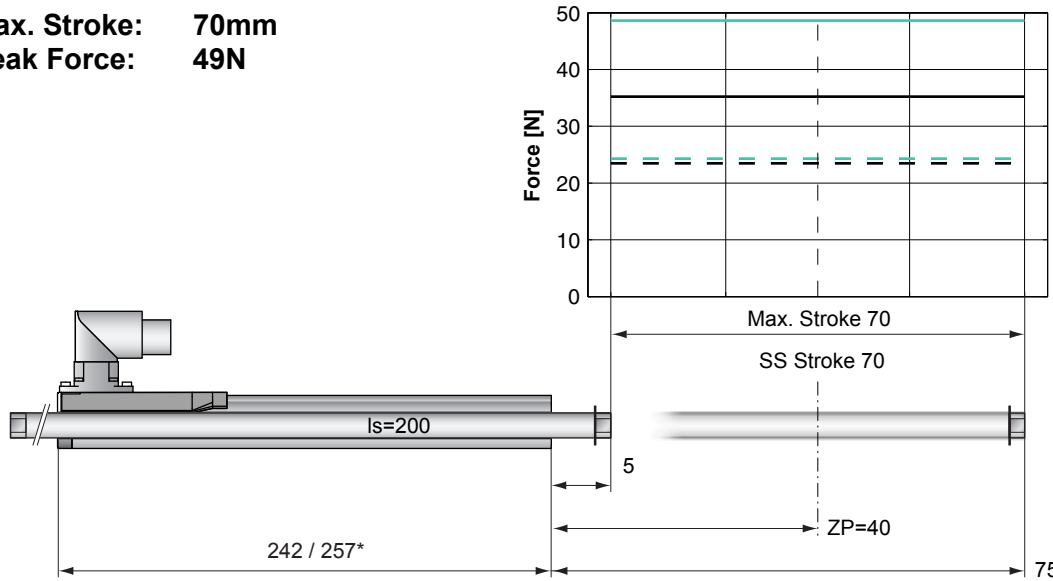

Standard Winding:
 — E1100, 72VDC & E1001, 72VDC
 - - - E100, 48VDC

Fast Winding:
 — E1100, 72VDC & E1001, 72VDC
 - - - E100, 48VDC

Dimensions in mm
 *Cable Type

Motor Specification

	P01-	Connector Type		Cable Type	
		Standard Winding 23x160/70x70-R	Fast Winding 23x160F/70x70-R	Standard Winding 23x160/70x70-D100 23x160/70x70-R20	Fast Winding 23x160F/70x70-R20
Extended Stroke ES	mm (in)	70 (2.76)	70 (2.76)	70 (2.76)	70 (2.76)
Standard Stroke SS	mm (in)	70 (2.76)	70 (2.76)	70 (2.76)	70 (2.76)
Peak Force E1100 / E1001	N (lbf)	35 (7.9)	49 (10.9)	35 (7.9)	49 (10.9)
Peak Force E100	N (lbf)	23 (5.3)	24 (5.5)	23 (5.3)	24 (5.5)
Cont. Force	N (lbf)	9 (2.1)	9 (2.1)	9 (2.1)	9 (2.1)
Cont. Force Fan cooling	N (lbf)	18 (4.0)	18 (4.0)	18 (4.0)	18 (4.0)
Border Force	%	100	100	100	100
Force Constant	N/A (lbf/A)	12.4 (2.79)	8.1 (1.82)	12.4 (2.79)	8.1 (1.82)
Max. Current @ 72VDC	A	2.8	6.0	2.8	6.0
Max. Current @ 48VDC	A	1.9	4.3	1.9	4.3
Max. Velocity @ 72VDC	m/s (in/s)	5.3 (210)	8.2 (322)	5.3 (210)	8.2 (322)
Max. Velocity @ 48VDC	m/s (in/s)	3.6 (140)	5.5 (215)	3.6 (140)	5.5 (215)
Phase Resist. 25/80 °C	Ohm	20.6/24.9	9.0/10.9	20.6/24.9	9.0/10.9
Phase Inductance	mH	2.7	1.2	2.7	1.2
Thermal Resistance	°K/W	3.9	3.8	3.9	3.8
Thermal Time Const.	sec	1900	1800	1900	1800
Stator Diameter	mm (in)	23 (0.91)	23 (0.91)	23 (0.91)	23 (0.91)
Stator Length	mm (in)	242 (9.53)	242 (9.53)	257 (10.12)	257 (10.12)
Stator Mass	g (lb)	450 (0.99)	450 (0.99)	450 (0.99)	450 (0.99)
Slider Diameter	mm (in)	12 (0.47)	12 (0.47)	12 (0.47)	12 (0.47)
Slider Length	mm (in)	200 (7.87)	200 (7.87)	200 (7.87)	200 (7.87)
Slider Mass	g (lb)	112 (0.25)	112 (0.25)	112 (0.25)	112 (0.25)
Position Repeatability	mm (in)	±0.05 (±0.0020)	±0.05 (±0.0020)	±0.05 (±0.0020)	±0.05 (±0.0020)
Linearity	%	±0.55	±0.55	±0.55	±0.55
Repeatability with EPS	mm (in)	±0.01 (±0.0004)	±0.01 (±0.0004)	±0.01 (±0.0004)	±0.01 (±0.0004)
Linearity with EPS	mm (in)	±0.01 (±0.0004)	±0.01 (±0.0004)	±0.01 (±0.0004)	±0.01 (±0.0004)

Position-Time Diagram

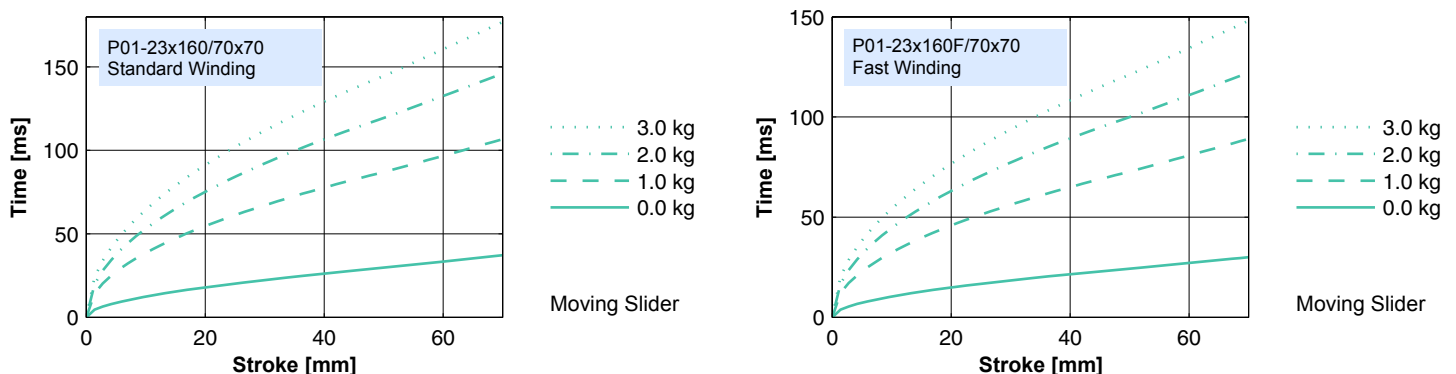

Connector Type

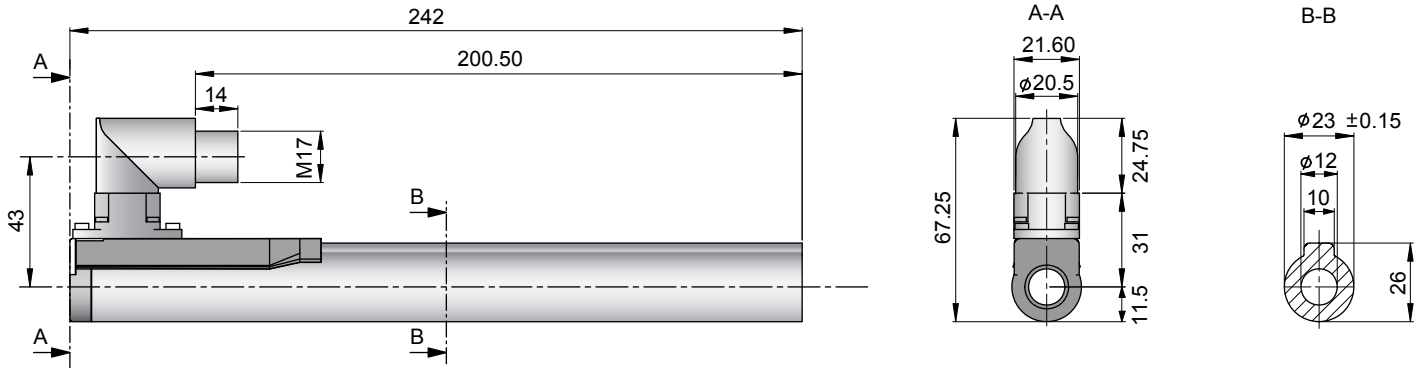

Linear Motor		Stator		Slider		
Type	Art.No	Type	Art. No.	Type	Art No.	
P01-23x160/70x70-R	-->	PS01-23x160-R	0150-1234	&	PL01-12x200/100	0150-1305
P01-23x160F/70x70-R	-->	PS01-23x160F-R	0150-1235	&	PL01-12x200/100	0150-1305

Cable Type

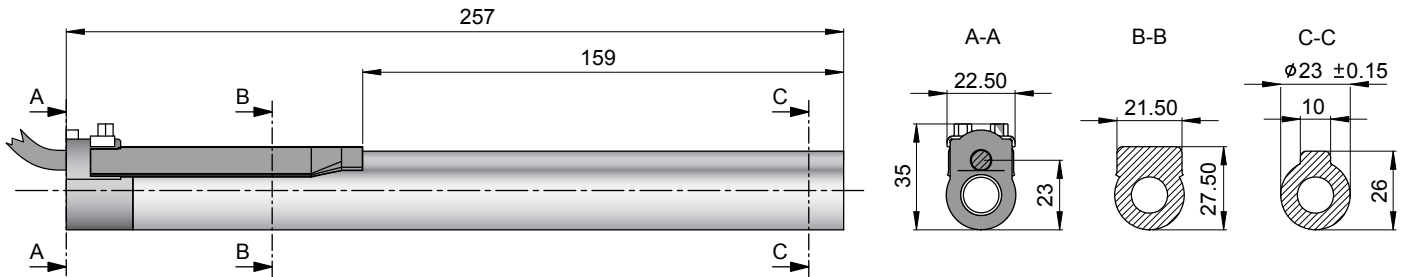

Linear Motor		Stator		Slider		
Type	Art.No	Type	Art. No.	Type	Art No.	
P01-23x160/70x70-D100	-->	PS01-23x160-D100	0150-1202	&	PL01-12x200/100	0150-1305
P01-23x160/70x70-R20	-->	PS01-23x160-R20	0150-1242	&	PL01-12x200/100	0150-1305
P01-23x160F/70x70-R20	-->	PS01-23x160F-R20	0150-1243	&	PL01-12x200/100	0150-1305

Slider

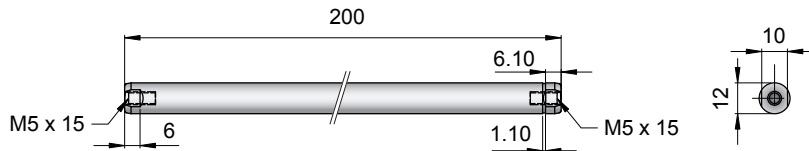

Standard Type		Slider Standard		PL01-12x200/100	
Special Sliders		Heavy Duty Slider with WC/C-Coating		PL02-12x200/100	
		Hollow Slider hole diameter 4.2mm		PL01-12x200/100-L	
					0150-1305
					0150-1308
					on request

Connectors

Motor Connector Wiring

Cable Length:
P01-23x160... 1.0m
P01-23x160...-R20 0.2m

		P01-23...-R	P01-23...-R20	P01-23...
Ph 1+	red	1	1	
Ph 1-	pink	2	6	
Ph 2+	blue	3	2	
Ph 2-	grey	4	7	
+5VDC	white	A	3	
GND	inner Shield	B	8	
Sine	yellow	C	4	
Cosine	green	D	9	
Temp.	black	E	5	
Shield	outer Shield	Case	Case	

Accessoires

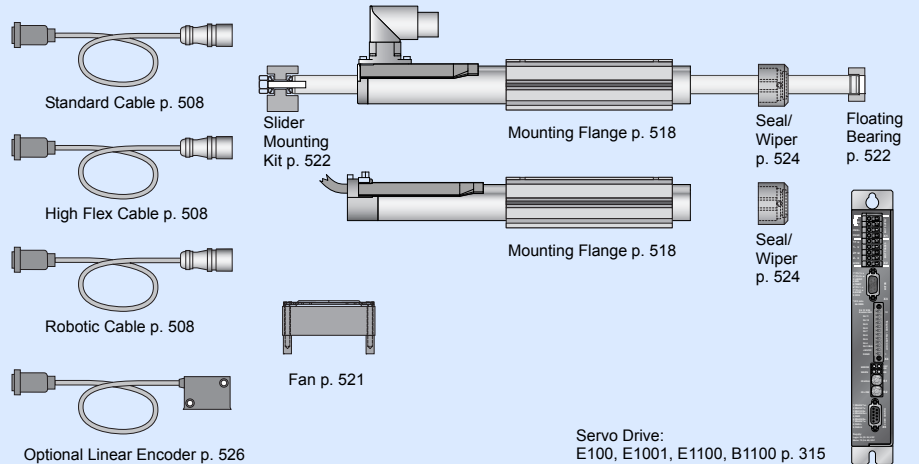

Max. Stroke: 100mm
Peak Force: 65N

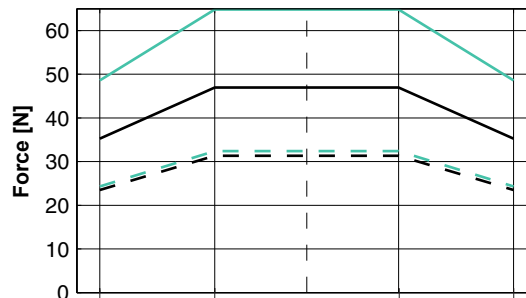
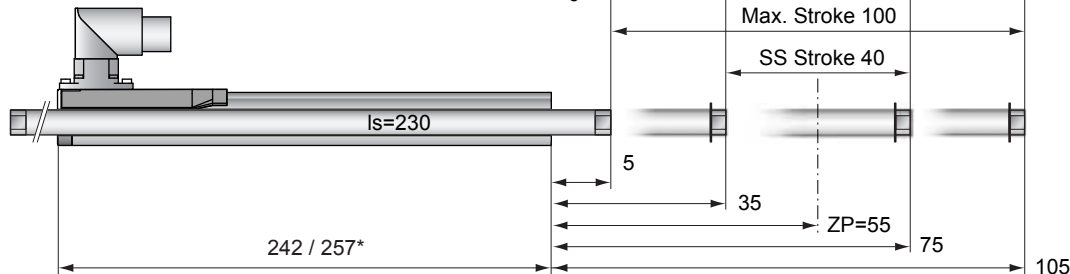

Standard Winding:
 — E1100, 72VDC & E1001, 72VDC
 - - - E100, 48VDC

Fast Winding:
 — E1100, 72VDC & E1001, 72VDC
 - - - E100, 48VDC

Dimensions in mm
 *Cable Type

Motor Specification

	P01-	Connector Type		Cable Type	
		Standard Winding 23x160/40x100-R	Fast Winding 23x160F/40x100-R	Standard Winding 23x160/40x100-D100 23x160/40x100-R20	Fast Winding 23x160F/40x100-R20
Extended Stroke ES	mm (in)	100 (3.94)	100 (3.94)	100 (3.94)	100 (3.94)
Standard Stroke SS	mm (in)	40 (1.57)	40 (1.57)	40 (1.57)	40 (1.57)
Peak Force E1100 / E1001	N (lbf)	47 (10.6)	65 (14.6)	47 (10.6)	65 (14.6)
Peak Force E100	N (lbf)	31 (7.0)	32 (7.3)	31 (7.0)	32 (7.3)
Cont. Force	N (lbf)	12 (2.8)	12 (2.8)	12 (2.8)	12 (2.8)
Cont. Force Fan cooling	N (lbf)	24 (5.3)	24 (5.3)	24 (5.3)	24 (5.3)
Border Force	%	75	75	75	75
Force Constant	N/A (lbf/A)	16.6 (3.72)	10.8 (2.43)	16.6 (3.72)	10.8 (2.43)
Max. Current @ 72VDC	A	2.8	6.0	2.8	6.0
Max. Current @ 48VDC	A	1.9	4.3	1.9	4.3
Max. Velocity @ 72VDC	m/s (in/s)	4.0 (157)	6.1 (241)	4.0 (157)	6.1 (241)
Max. Velocity @ 48VDC	m/s (in/s)	2.7 (105)	4.1 (161)	2.7 (105)	4.1 (161)
Phase Resist. 25/80 °C	Ohm	20.6/24.9	9.0/10.9	20.6/24.9	9.0/10.9
Phase Inductance	mH	2.7	1.2	2.7	1.2
Thermal Resistance	°K/W	3.9	3.8	3.9	3.8
Thermal Time Const.	sec	1900	1800	1900	1800
Stator Diameter	mm (in)	23 (0.91)	23 (0.91)	23 (0.91)	23 (0.91)
Stator Length	mm (in)	242 (9.53)	242 (9.53)	257 (10.12)	257 (10.12)
Stator Mass	g (lb)	450 (0.99)	450 (0.99)	450 (0.99)	450 (0.99)
Slider Diameter	mm (in)	12 (0.47)	12 (0.47)	12 (0.47)	12 (0.47)
Slider Length	mm (in)	230 (9.06)	230 (9.06)	230 (9.06)	230 (9.06)
Slider Mass	g (lb)	137 (0.30)	137 (0.30)	137 (0.30)	137 (0.30)
Position Repeatability	mm (in)	±0.05 (±0.0020)	±0.05 (±0.0020)	±0.05 (±0.0020)	±0.05 (±0.0020)
Linearity	%	±0.45	±0.45	±0.45	±0.45
Repeatability with EPS	mm (in)	±0.01 (±0.0004)	±0.01 (±0.0004)	±0.01 (±0.0004)	±0.01 (±0.0004)
Linearity with EPS	mm (in)	±0.01 (±0.0004)	±0.01 (±0.0004)	±0.01 (±0.0004)	±0.01 (±0.0004)

Position-Time Diagram

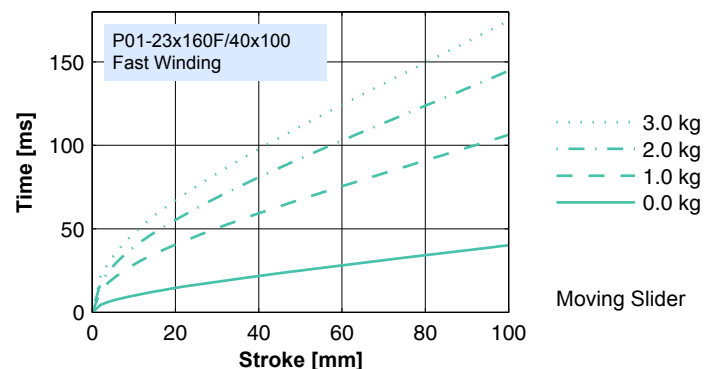
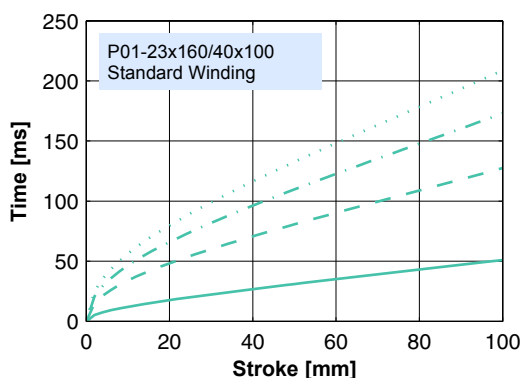

Connector Type

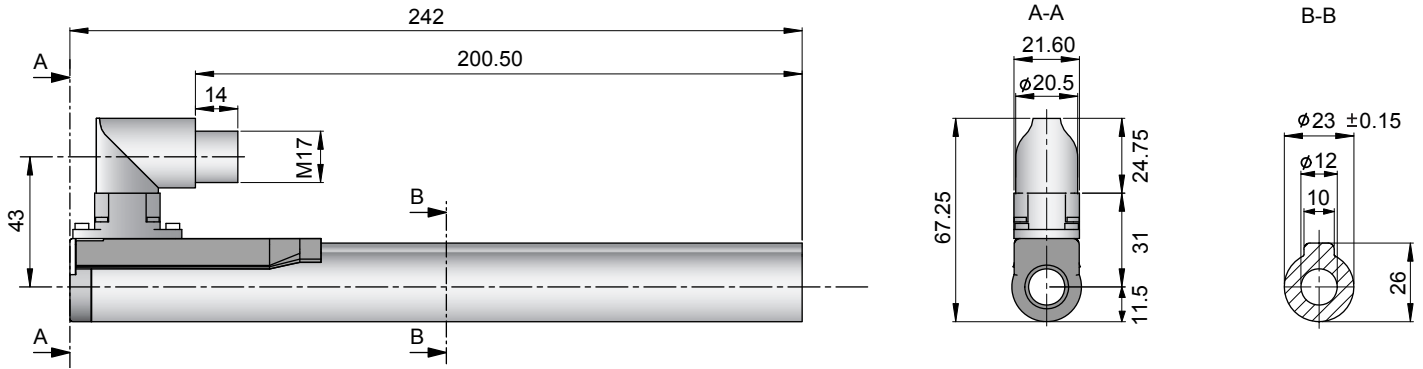

Linear Motor		Stator		Slider	
Type	Art.No	Type	Art. No.	Type	Art No.
P01-23x160/40x100-R	-->	PS01-23x160-R	0150-1234	& PL01-12x230/130	0150-1306
P01-23x160F/40x100-R	-->	PS01-23x160F-R	0150-1235	& PL01-12x230/130	0150-1306

Cable Type

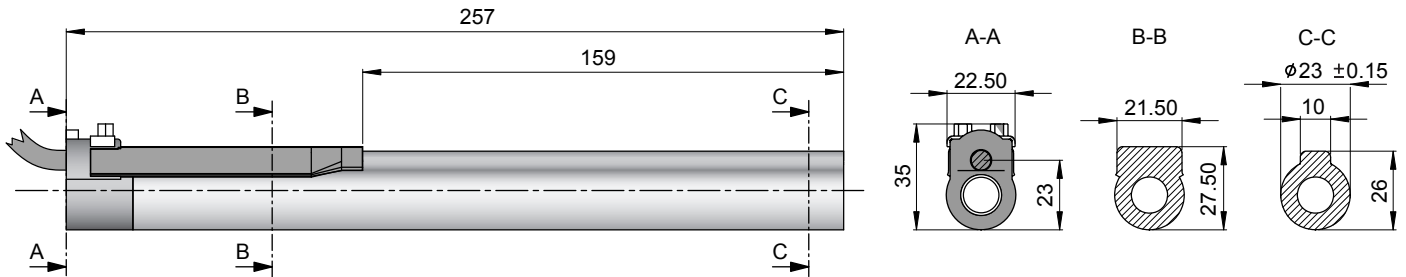

Linear Motor		Stator		Slider	
Type	Art.No	Type	Art. No.	Type	Art No.
P01-23x160/40x100-D100	-->	PS01-23x160-D100	0150-1202	& PL01-12x230/130	0150-1306
P01-23x160/40x100-R20	-->	PS01-23x160-R20	0150-1242	& PL01-12x230/130	0150-1306
P01-23x160F/40x100-R20	-->	PS01-23x160F-R20	0150-1243	& PL01-12x230/130	0150-1306

Slider

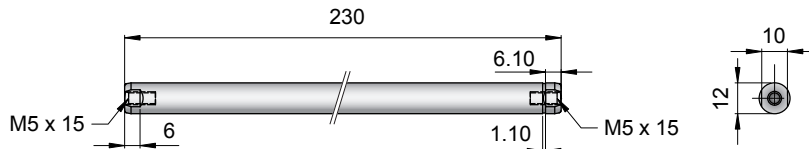

Standard Type	Slider Standard	PL01-12x230/130	0150-1306
Special Sliders	Heavy Duty Slider with WC/C-Coating	PL02-12x230/130	0150-1309
	Hollow Slider hole diameter 4.2mm	PL01-12x230/130-L	on request

Connectors

Motor Connector Wiring

Cable Length:
P01-23x160... 1.0m
P01-23x160...-R20 0.2m

		P01-23...-R	P01-23...-R20	P01-23...
Ph 1+	red	1	1	
Ph 1-	pink	2	6	
Ph 2+	blue	3	2	
Ph 2-	grey	4	7	
+5VDC	white	A	3	
GND	inner Shield	B	8	
Sine	yellow	C	4	
Cosine	green	D	9	
Temp.	black	E	5	
Shield	outer Shield	Case	Case	

Accessoires

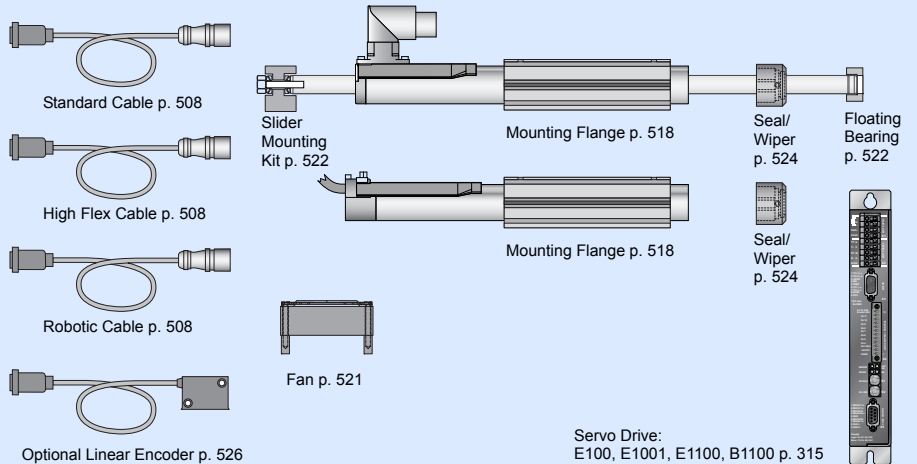

Max. Stroke: 140mm
Peak Force: 86N

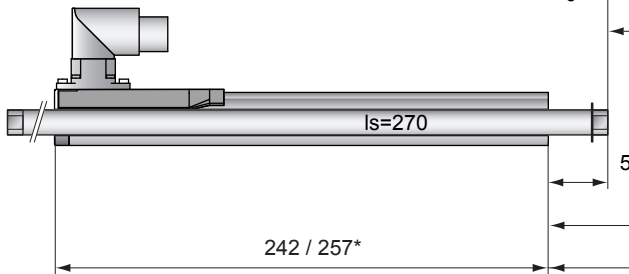
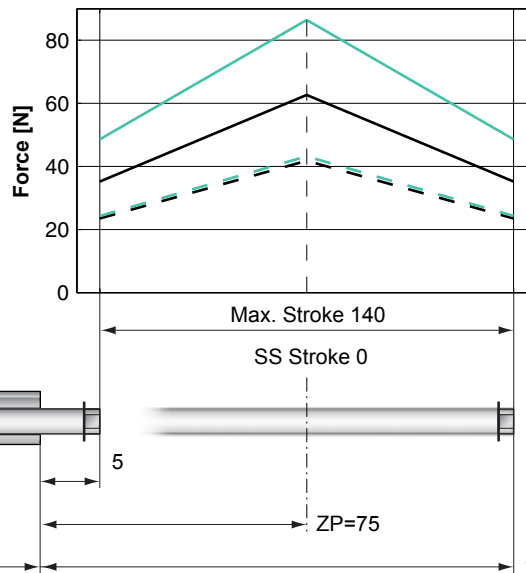

- Standard Winding:**
 — E1100, 72VDC & E1001, 72VDC
 - - - E100, 48VDC
- Fast Winding:**
 — E1100, 72VDC & E1001, 72VDC
 - - - E100, 48VDC

Dimensions in mm
 *Cable Type

Motor Specification

	P01-23x160/0x140-R	Connector Type		Cable Type	
		Standard Winding	Fast Winding	Standard Winding	Fast Winding
		23x160/0x140-R	23x160F/0x140-R	23x160/0x140-D100 23x160/0x140-R20	23x160F/0x140-R20
Extended Stroke ES	mm (in)	140 (5.51)	140 (5.51)	140 (5.51)	140 (5.51)
Standard Stroke SS	mm (in)	0 (0.00)	0 (0.00)	0 (0.00)	0 (0.00)
Peak Force E1100 / E1001	N (lbf)	63 (14.1)	86 (19.4)	63 (14.1)	86 (19.4)
Peak Force E100	N (lbf)	42 (9.4)	43 (9.7)	42 (9.4)	43 (9.7)
Cont. Force	N (lbf)	17 (3.7)	17 (3.7)	17 (3.7)	17 (3.7)
Cont. Force Fan cooling	N (lbf)	31 (7.1)	32 (7.1)	31 (7.1)	32 (7.1)
Border Force	%	56	56	56	56
Force Constant	N/A (lbf/A)	22.1 (4.96)	14.4 (3.24)	22.1 (4.96)	14.4 (3.24)
Max. Current @ 72VDC	A	2.8	6.0	2.8	6.0
Max. Current @ 48VDC	A	1.9	4.3	1.9	4.3
Max. Velocity @ 72VDC	m/s (in/s)	3.0 (118)	4.6 (181)	3.0 (118)	4.6 (181)
Max. Velocity @ 48VDC	m/s (in/s)	2.0 (79)	3.1 (121)	2.0 (79)	3.1 (121)
Phase Resist. 25/80 °C	Ohm	20.6/24.9	9.0/10.9	20.6/24.9	9.0/10.9
Phase Inductance	mH	2.7	1.2	2.7	1.2
Thermal Resistance	°K/W	3.9	3.8	3.9	3.8
Thermal Time Const.	sec	1900	1800	1900	1800
Stator Diameter	mm (in)	23 (0.91)	23 (0.91)	23 (0.91)	23 (0.91)
Stator Length	mm (in)	242 (9.53)	242 (9.53)	257 (10.12)	257 (10.12)
Stator Mass	g (lb)	450 (0.99)	450 (0.99)	450 (0.99)	450 (0.99)
Slider Diameter	mm (in)	12 (0.47)	12 (0.47)	12 (0.47)	12 (0.47)
Slider Length	mm (in)	270 (10.63)	270 (10.63)	270 (10.63)	270 (10.63)
Slider Mass	g (lb)	171 (0.38)	171 (0.38)	171 (0.38)	171 (0.38)
Position Repeatability	mm (in)	±0.05 (±0.0020)	±0.05 (±0.0020)	±0.05 (±0.0020)	±0.05 (±0.0020)
Linearity	%	±0.35	±0.35	±0.35	±0.35
Repeatability with EPS	mm (in)	±0.01 (±0.0004)	±0.01 (±0.0004)	±0.01 (±0.0004)	±0.01 (±0.0004)
Linearity with EPS	mm (in)	±0.01 (±0.0004)	±0.01 (±0.0004)	±0.01 (±0.0004)	±0.01 (±0.0004)

Position-Time Diagram

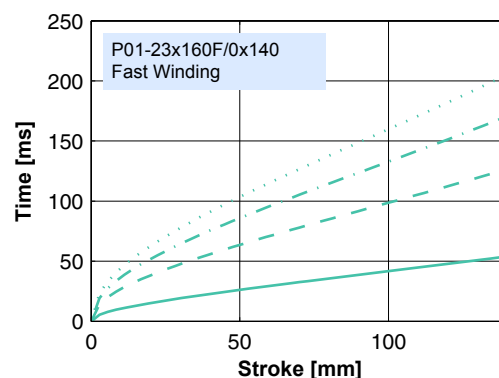
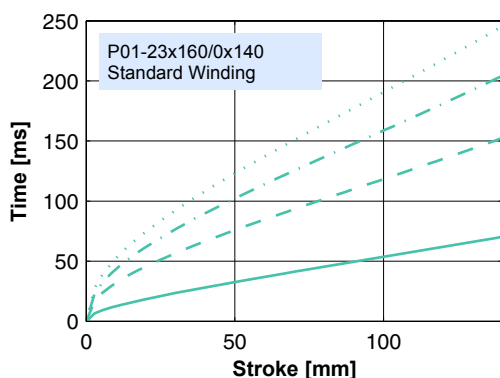

Moving Slider

Moving Slider

Connector Type

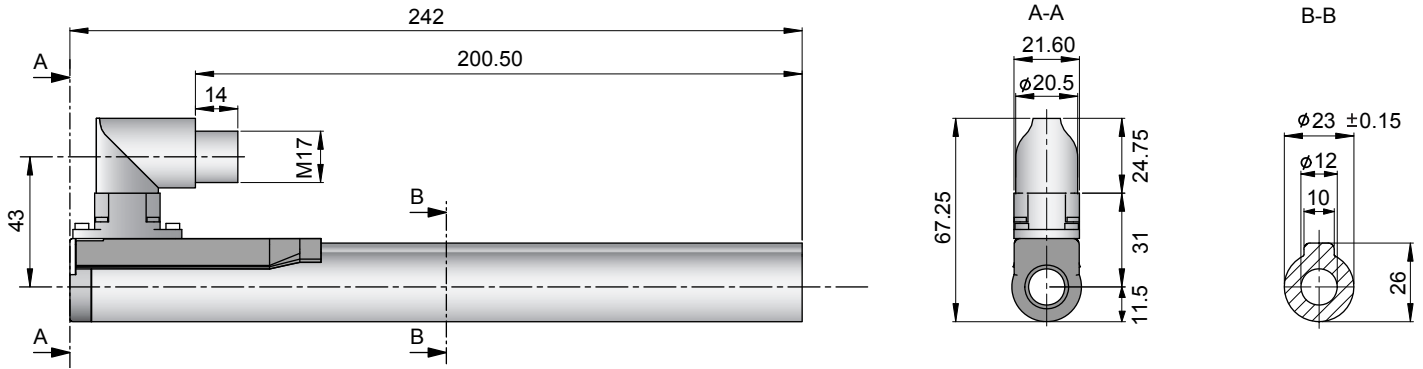

Linear Motor		Stator		Slider	
Type	Art.No	Type	Art. No.	Type	Art No.
P01-23x160/0x140-R	-->	PS01-23x160-R	0150-1234	& PL01-12x270/170	0150-1307
P01-23x160F/0x140-R	-->	PS01-23x160F-R	0150-1235	& PL01-12x270/170	0150-1307

Cable Type

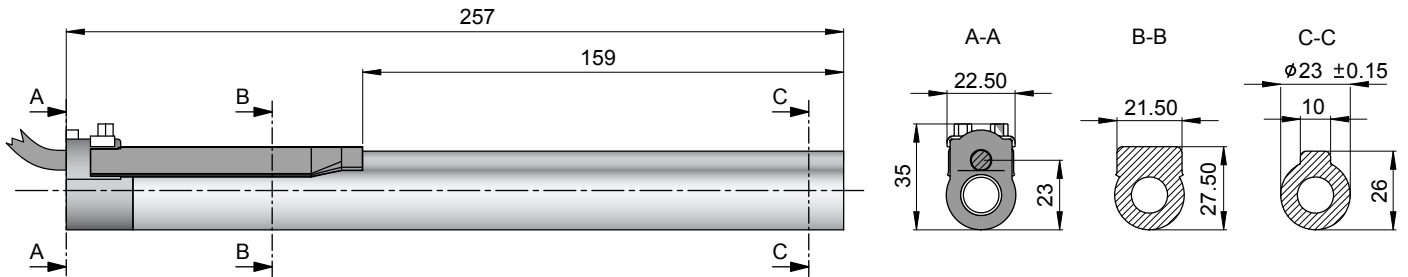

Linear Motor		Stator		Slider	
Type	Art.No	Type	Art. No.	Type	Art No.
P01-23x160/0x140-D100	-->	PS01-23x160-D100	0150-1202	& PL01-12x270/170	0150-1307
P01-23x160/0x140-R20	-->	PS01-23x160-R20	0150-1242	& PL01-12x270/170	0150-1307
P01-23x160F/0x140-R20	-->	PS01-23x160F-R20	0150-1243	& PL01-12x270/170	0150-1307

Slider

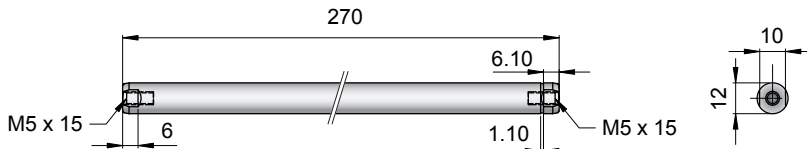

Standard Type		Slider Standard		PL01-12x270/170	
Special Sliders		Heavy Duty Slider with WC/C-Coating		PL02-12x270/170	
		Hollow Slider hole diameter 4.2mm		PL01-12x270/170-L	
					0150-1307
					0150-1310
					0150-1393

Connectors

Motor Connector Wiring

Cable Length:
P01-23x160... 1.0m
P01-23x160...-R20 0.2m

		P01-23...-R	P01-23...-R20	P01-23...
Ph 1+	red	1	1	
Ph 1-	pink	2	6	
Ph 2+	blue	3	2	
Ph 2-	grey	4	7	
+5VDC	white	A	3	
GND	inner Shield	B	8	
Sine	yellow	C	4	
Cosine	green	D	9	
Temp.	black	E	5	
Shield	outer Shield	Case	Case	

Accessoires

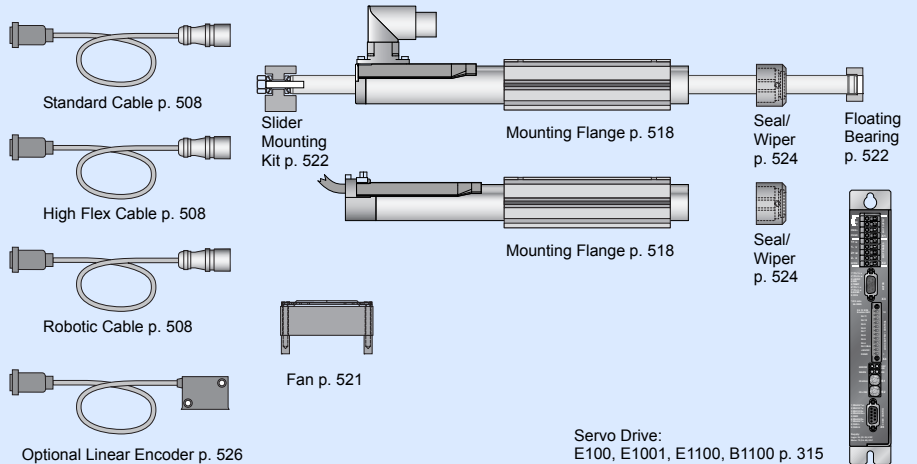

Max. Stroke: 210mm
Peak Force: 86N

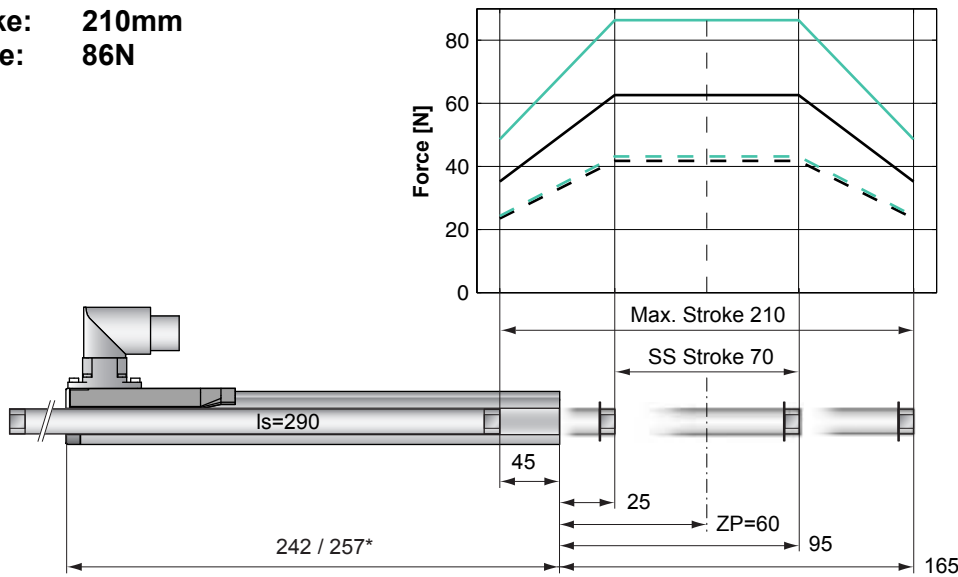

Standard Winding:
 — E1100, 72VDC & E1001, 72VDC
 - - - E100, 48VDC

Fast Winding:
 — E1100, 72VDC & E1001, 72VDC
 - - - E100, 48VDC

Dimensions in mm
 *Cable Type

Motor Specification

	P01-	Connector Type		Cable Type	
		Standard Winding 23x160/70x210-R	Fast Winding 23x160F/70x210-R	Standard Winding 23x160/70x210-D100 23x160/70x210-R20	Fast Winding 23x160F/70x210-R20
Extended Stroke ES	mm (in)	210 (8.27)	210 (8.27)	210 (8.27)	210 (8.27)
Standard Stroke SS	mm (in)	70 (2.76)	70 (2.76)	70 (2.76)	70 (2.76)
Peak Force E1100 / E1001	N (lbf)	63 (14.1)	86 (19.4)	63 (14.1)	86 (19.4)
Peak Force E100	N (lbf)	42 (9.4)	43 (9.7)	42 (9.4)	43 (9.7)
Cont. Force	N (lbf)	17 (3.7)	17 (3.7)	17 (3.7)	17 (3.7)
Cont. Force Fan cooling	N (lbf)	31 (7.1)	32 (7.1)	31 (7.1)	32 (7.1)
Border Force	%	56	56	56	56
Force Constant	N/A (lbf/A)	22.1 (4.96)	14.4 (3.24)	22.1 (4.96)	14.4 (3.24)
Max. Current @ 72VDC	A	2.8	6.0	2.8	6.0
Max. Current @ 48VDC	A	1.9	4.3	1.9	4.3
Max. Velocity @ 72VDC	m/s (in/s)	3.0 (118)	4.6 (181)	3.0 (118)	4.6 (181)
Max. Velocity @ 48VDC	m/s (in/s)	2.0 (79)	3.1 (121)	2.0 (79)	3.1 (121)
Phase Resist. 25/80 °C	Ohm	20.6/24.9	9.0/10.9	20.6/24.9	9.0/10.9
Phase Inductance	mH	2.7	1.2	2.7	1.2
Thermal Resistance	°K/W	3.9	3.8	3.9	3.8
Thermal Time Const.	sec	1900	1800	1900	1800
Stator Diameter	mm (in)	23 (0.91)	23 (0.91)	23 (0.91)	23 (0.91)
Stator Length	mm (in)	242 (9.53)	242 (9.53)	257 (10.12)	257 (10.12)
Stator Mass	g (lb)	450 (0.99)	450 (0.99)	450 (0.99)	450 (0.99)
Slider Diameter	mm (in)	12 (0.47)	12 (0.47)	12 (0.47)	12 (0.47)
Slider Length	mm (in)	290 (11.42)	290 (11.42)	290 (11.42)	290 (11.42)
Slider Mass	g (lb)	220 (0.49)	220 (0.49)	220 (0.49)	220 (0.49)
Position Repeatability	mm (in)	±0.05 (±0.0020)	±0.05 (±0.0020)	±0.05 (±0.0020)	±0.05 (±0.0020)
Linearity	%	±0.30	±0.30	±0.30	±0.30
Repeatability with EPS	mm (in)	±0.01 (±0.0004)	±0.01 (±0.0004)	±0.01 (±0.0004)	±0.01 (±0.0004)
Linearity with EPS	mm (in)	±0.01 (±0.0004)	±0.01 (±0.0004)	±0.01 (±0.0004)	±0.01 (±0.0004)

Position-Time Diagram

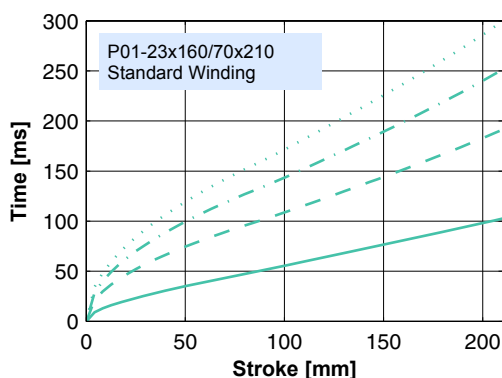

3.0 kg
 2.0 kg
 1.0 kg
 0.0 kg

Moving Slider

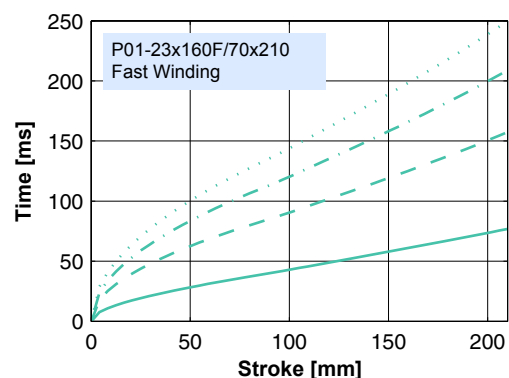

3.0 kg
 2.0 kg
 1.0 kg
 0.0 kg

Moving Slider

Connector Type

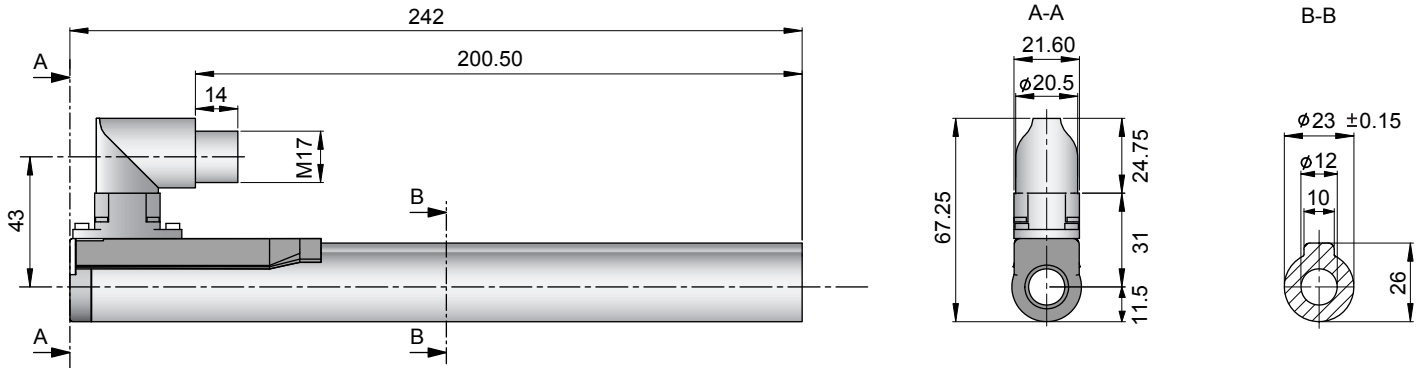

Linear Motor		Stator		Slider		
Type	Art.No	Type	Art. No.	Type	Art No.	
P01-23x160/70x210-R	-->	PS01-23x160-R	0150-1234	&	PL01-12x290/240	0150-1320
P01-23x160F/70x210-R	-->	PS01-23x160F-R	0150-1235	&	PL01-12x290/240	0150-1320

Cable Type

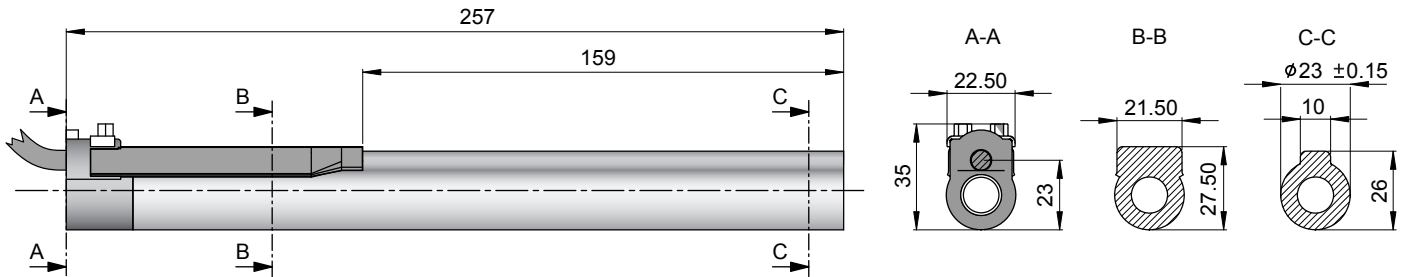

Linear Motor		Stator		Slider		
Type	Art.No	Type	Art. No.	Type	Art No.	
P01-23x160/70x210-D100	-->	PS01-23x160-D100	0150-1202	&	PL01-12x290/240	0150-1320
P01-23x160/70x210-R20	-->	PS01-23x160-R20	0150-1242	&	PL01-12x290/240	0150-1320
P01-23x160F/70x210-R20	-->	PS01-23x160F-R20	0150-1243	&	PL01-12x290/240	0150-1320

Slider

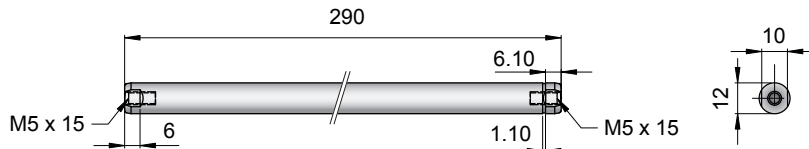

Standard Type		Slider Standard		PL01-12x290/240	
Special Sliders		Heavy Duty Slider with WC/C-Coating		PL02-12x290/240	
		Hollow Slider hole diameter 4.2mm		PL01-12x290/240-L	
					0150-1321
					0150-1363

Connectors

Motor Connector Wiring

Cable Length:
P01-23x160... 1.0m
P01-23x160...-R20 0.2m

		P01-23...-R	P01-23...-R20	P01-23...
Ph 1+	red	1	1	
Ph 1-	pink	2	6	
Ph 2+	blue	3	2	
Ph 2-	grey	4	7	
+5VDC	white	A	3	
GND	inner Shield	B	8	
Sine	yellow	C	4	
Cosine	green	D	9	
Temp.	black	E	5	
Shield	outer Shield	Case	Case	

Accessoires

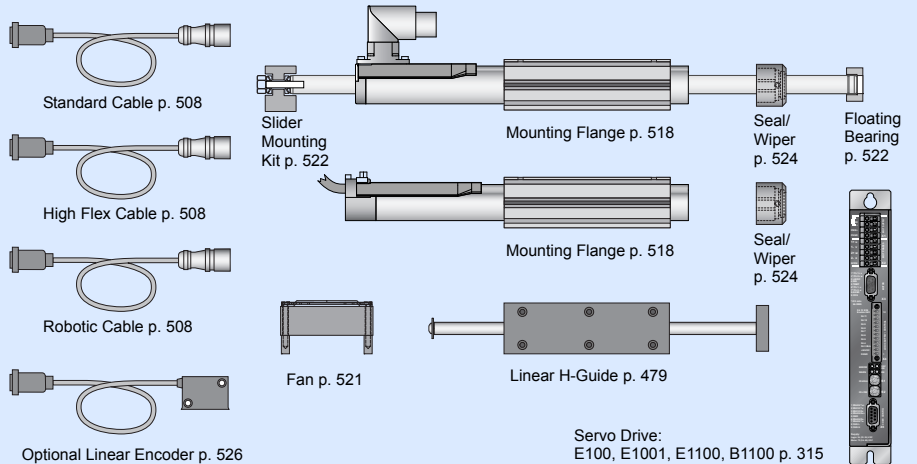

Max. Stroke: 270mm
Peak Force: 86N

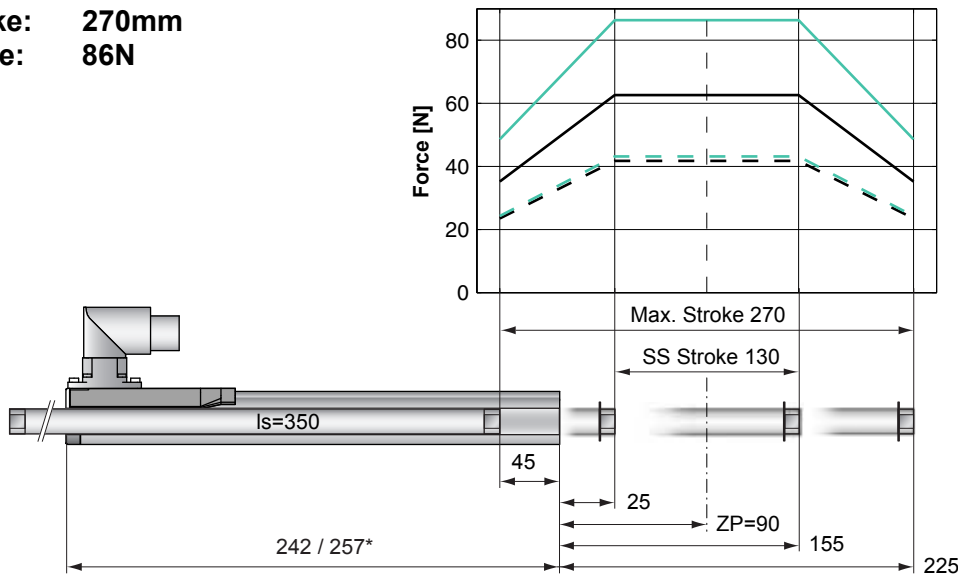

Dimensions in mm
 *Cable Type

Motor Specification

	P01-	Connector Type		Cable Type	
		Standard Winding 23x160/130x270-R	Fast Winding 23x160F/130x270-R	Standard Winding 23x160/130x270-D100 23x160/130x270-R20	Fast Winding 23x160F/130x270-R20
Extended Stroke ES	mm (in)	270 (10.63)	270 (10.63)	270 (10.63)	270 (10.63)
Standard Stroke SS	mm (in)	130 (5.12)	130 (5.12)	130 (5.12)	130 (5.12)
Peak Force E1100 / E1001	N (lbf)	63 (14.1)	86 (19.4)	63 (14.1)	86 (19.4)
Peak Force E100	N (lbf)	42 (9.4)	43 (9.7)	42 (9.4)	43 (9.7)
Cont. Force	N (lbf)	17 (3.7)	17 (3.7)	17 (3.7)	17 (3.7)
Cont. Force Fan cooling	N (lbf)	31 (7.1)	32 (7.1)	31 (7.1)	32 (7.1)
Border Force	%	56	56	56	56
Force Constant	N/A (lbf/A)	22.1 (4.96)	14.4 (3.24)	22.1 (4.96)	14.4 (3.24)
Max. Current @ 72VDC	A	2.8	6.0	2.8	6.0
Max. Current @ 48VDC	A	1.9	4.3	1.9	4.3
Max. Velocity @ 72VDC	m/s (in/s)	3.0 (118)	4.6 (181)	3.0 (118)	4.6 (181)
Max. Velocity @ 48VDC	m/s (in/s)	2.0 (79)	3.1 (121)	2.0 (79)	3.1 (121)
Phase Resist. 25/80 °C	Ohm	20.6/24.9	9.0/10.9	20.6/24.9	9.0/10.9
Phase Inductance	mH	2.7	1.2	2.7	1.2
Thermal Resistance	°K/W	3.9	3.8	3.9	3.8
Thermal Time Const.	sec	1900	1800	1900	1800
Stator Diameter	mm (in)	23 (0.91)	23 (0.91)	23 (0.91)	23 (0.91)
Stator Length	mm (in)	242 (9.53)	242 (9.53)	257 (10.12)	257 (10.12)
Stator Mass	g (lb)	450 (0.99)	450 (0.99)	450 (0.99)	450 (0.99)
Slider Diameter	mm (in)	12 (0.47)	12 (0.47)	12 (0.47)	12 (0.47)
Slider Length	mm (in)	350 (13.78)	350 (13.78)	350 (13.78)	350 (13.78)
Slider Mass	g (lb)	271 (0.60)	271 (0.60)	271 (0.60)	271 (0.60)
Position Repeatability	mm (in)	±0.05 (±0.0020)	±0.05 (±0.0020)	±0.05 (±0.0020)	±0.05 (±0.0020)
Linearity	%	±0.25	±0.25	±0.25	±0.25
Repeatability with EPS	mm (in)	±0.01 (±0.0004)	±0.01 (±0.0004)	±0.01 (±0.0004)	±0.01 (±0.0004)
Linearity with EPS	mm (in)	±0.01 (±0.0004)	±0.01 (±0.0004)	±0.01 (±0.0004)	±0.01 (±0.0004)

Position-Time Diagram

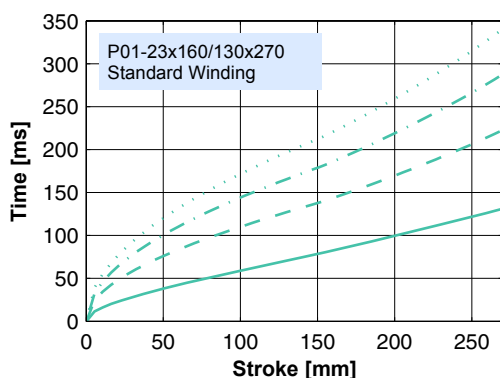

3.0 kg
 2.0 kg
 1.0 kg
 0.0 kg

Moving Slider

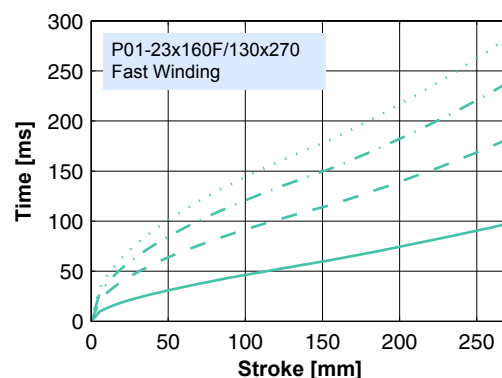

3.0 kg
 2.0 kg
 1.0 kg
 0.0 kg

Moving Slider

Connector Type

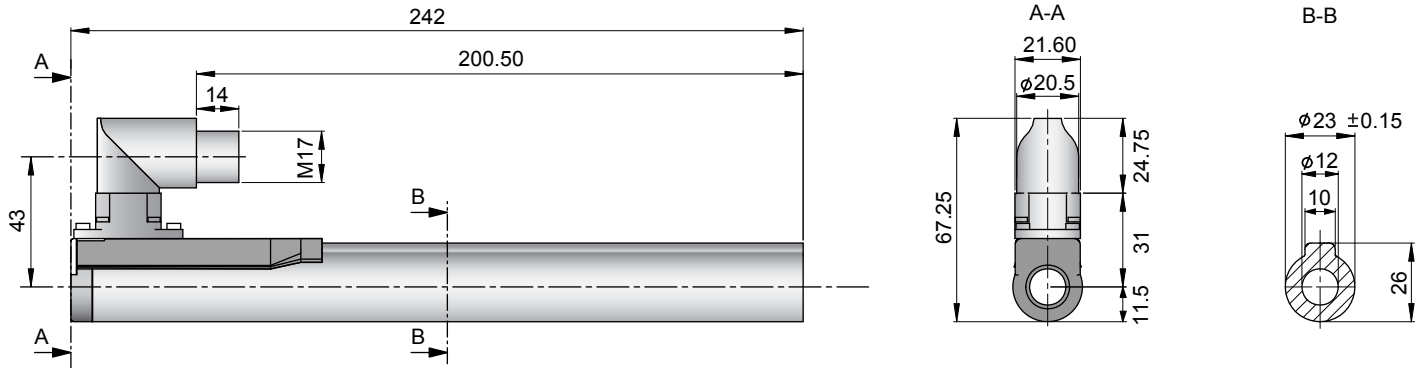

Linear Motor		Stator		Slider		
Type	Art.No	Type	Art. No.	Type	Art No.	
P01-23x160/130x270-R	-->	PS01-23x160-R	0150-1234	&	PL01-12x350/300	0150-1322
P01-23x160F/130x270-R	-->	PS01-23x160F-R	0150-1235	&	PL01-12x350/300	0150-1322

Cable Type

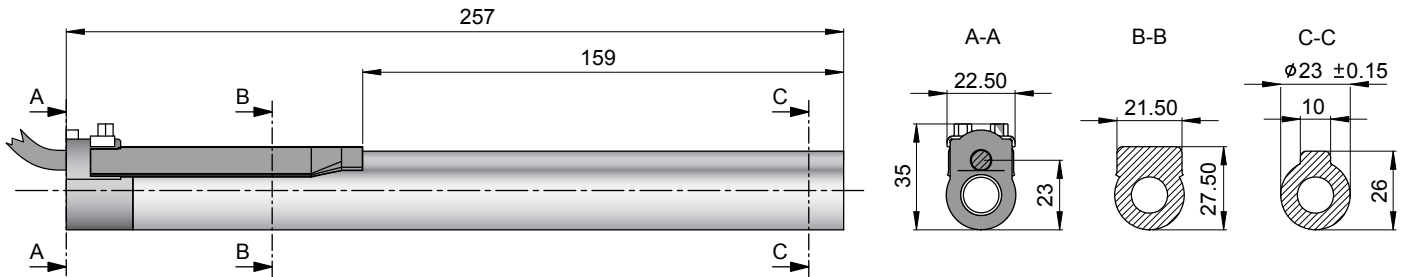

Linear Motor		Stator		Slider		
Type	Art.No	Type	Art. No.	Type	Art No.	
P01-23x160/130x270-D100	-->	PS01-23x160-D100	0150-1202	&	PL01-12x350/300	0150-1322
P01-23x160/130x270-R20	-->	PS01-23x160-R20	0150-1242	&	PL01-12x350/300	0150-1322
P01-23x160F/130x270-R20	-->	PS01-23x160F-R20	0150-1243	&	PL01-12x350/300	0150-1322

Slider

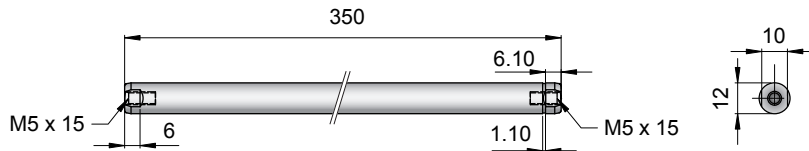

Standard Type	Slider Standard	PL01-12x350/300	0150-1322
Special Sliders	Heavy Duty Slider with WC/C-Coating	PL02-12x350/300	0150-1233
	Hollow Slider hole diameter 4.2mm	PL01-12x350/300-L	0150-1479

Connectors

Motor Connector Wiring

Cable Length:
P01-23x160... 1.0m
P01-23x160...-R20 0.2m

		P01-23...-R	P01-23...-R20	P01-23...
Ph 1+	red	1	1	
Ph 1-	pink	2	6	
Ph 2+	blue	3	2	
Ph 2-	grey	4	7	
+5VDC	white	A	3	
GND	inner Shield	B	8	
Sine	yellow	C	4	
Cosine	green	D	9	
Temp.	black	E	5	
Shield	outer Shield	Case	Case	

Accessoires

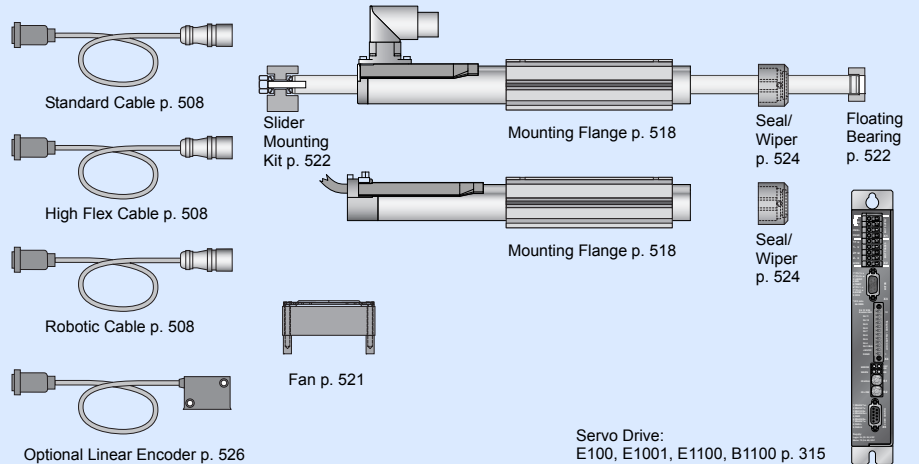

Max. Stroke: 340mm
Peak Force: 86N

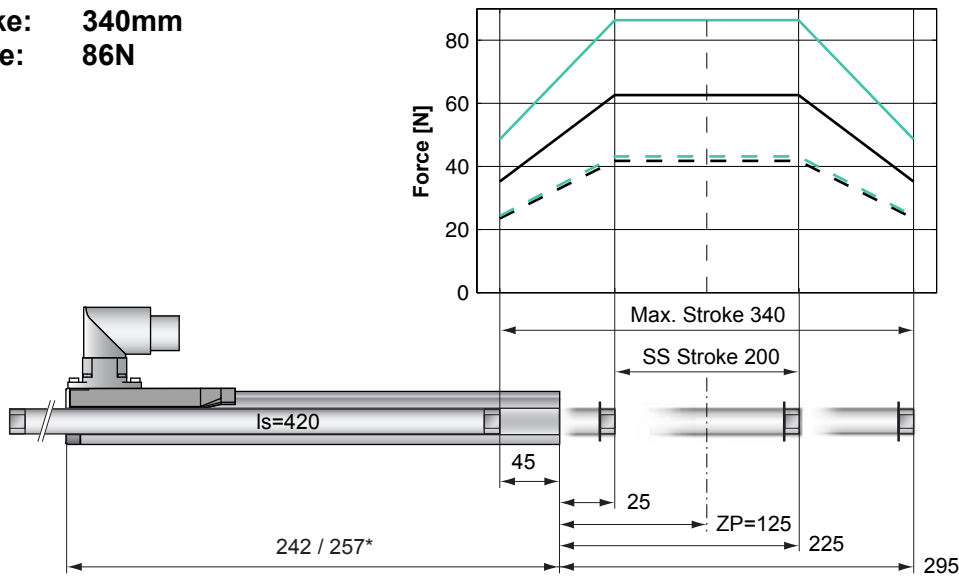

Dimensions in mm
 *Cable Type

Motor Specification

	P01-	Connector Type		Cable Type	
		Standard Winding 23x160/200x340-R	Fast Winding 23x160F/200x340-R	Standard Winding 23x160/200x340-D100 23x160/200x340-R20	Fast Winding 23x160F/200x340-R20
Extended Stroke ES	mm (in)	340 (13.39)	340 (13.39)	340 (13.39)	340 (13.39)
Standard Stroke SS	mm (in)	200 (7.87)	200 (7.87)	200 (7.87)	200 (7.87)
Peak Force E1100 / E1001	N (lbf)	63 (14.1)	86 (19.4)	63 (14.1)	86 (19.4)
Peak Force E100	N (lbf)	42 (9.4)	43 (9.7)	42 (9.4)	43 (9.7)
Cont. Force	N (lbf)	17 (3.7)	17 (3.7)	17 (3.7)	17 (3.7)
Cont. Force Fan cooling	N (lbf)	31 (7.1)	32 (7.1)	31 (7.1)	32 (7.1)
Border Force	%	56	56	56	56
Force Constant	N/A (lbf/A)	22.1 (4.96)	14.4 (3.24)	22.1 (4.96)	14.4 (3.24)
Max. Current @ 72VDC	A	2.8	6.0	2.8	6.0
Max. Current @ 48VDC	A	1.9	4.3	1.9	4.3
Max. Velocity @ 72VDC	m/s (in/s)	3.0 (118)	4.6 (181)	3.0 (118)	4.6 (181)
Max. Velocity @ 48VDC	m/s (in/s)	2.0 (79)	3.1 (121)	2.0 (79)	3.1 (121)
Phase Resist. 25/80 °C	Ohm	20.6/24.9	9.0/10.9	20.6/24.9	9.0/10.9
Phase Inductance	mH	2.7	1.2	2.7	1.2
Thermal Resistance	°K/W	3.9	3.8	3.9	3.8
Thermal Time Const.	sec	1900	1800	1900	1800
Stator Diameter	mm (in)	23 (0.91)	23 (0.91)	23 (0.91)	23 (0.91)
Stator Length	mm (in)	242 (9.53)	242 (9.53)	257 (10.12)	257 (10.12)
Stator Mass	g (lb)	450 (0.99)	450 (0.99)	450 (0.99)	450 (0.99)
Slider Diameter	mm (in)	12 (0.47)	12 (0.47)	12 (0.47)	12 (0.47)
Slider Length	mm (in)	420 (16.54)	420 (16.54)	420 (16.54)	420 (16.54)
Slider Mass	g (lb)	330 (0.73)	330 (0.73)	330 (0.73)	330 (0.73)
Position Repeatability	mm (in)	±0.05 (±0.0020)	±0.05 (±0.0020)	±0.05 (±0.0020)	±0.05 (±0.0020)
Linearity	%	±0.25	±0.25	±0.25	±0.25
Repeatability with EPS	mm (in)	±0.01 (±0.0004)	±0.01 (±0.0004)	±0.01 (±0.0004)	±0.01 (±0.0004)
Linearity with EPS	mm (in)	±0.01 (±0.0004)	±0.01 (±0.0004)	±0.01 (±0.0004)	±0.01 (±0.0004)

Position-Time Diagram

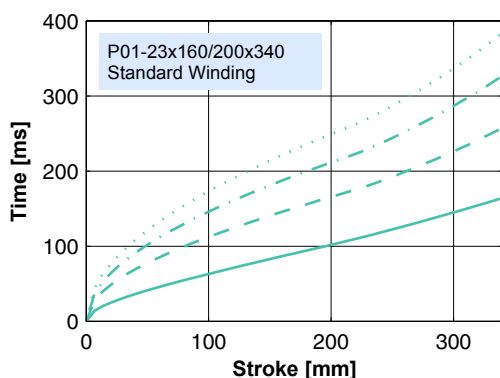

Moving Slider

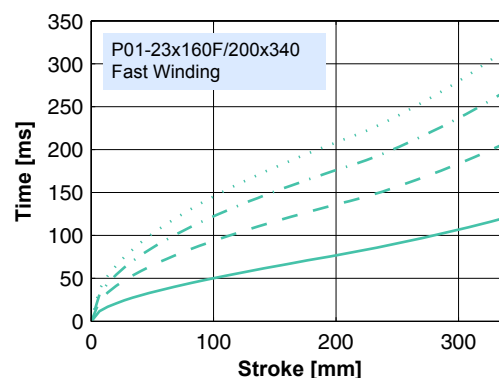

Moving Slider

Connector Type

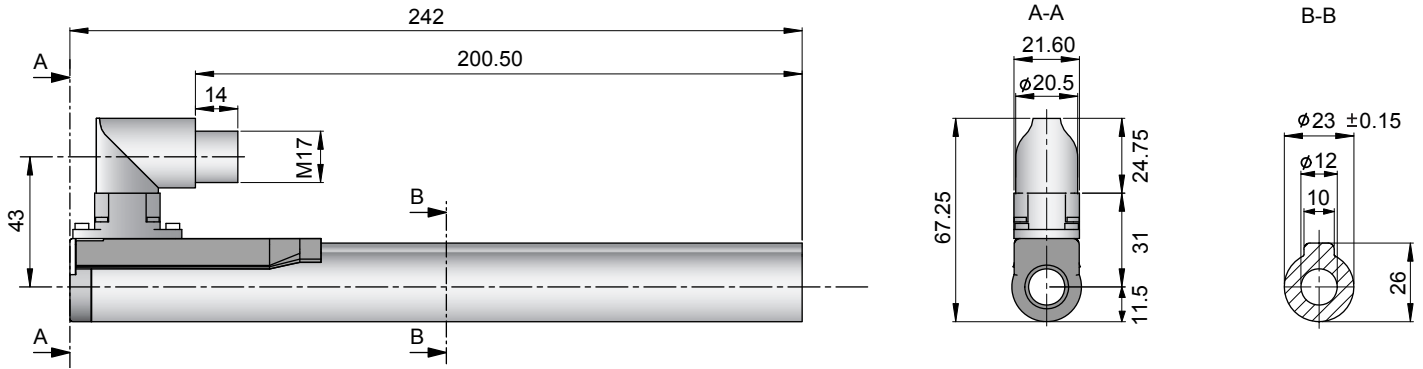

Linear Motor		Stator		Slider	
Type	Art.No	Type	Art. No.	Type	Art No.
P01-23x160/200x340-R	-->	PS01-23x160-R	0150-1234	& PL01-12x420/370	0150-1324
P01-23x160F/200x340-R	-->	PS01-23x160F-R	0150-1235	& PL01-12x420/370	0150-1324

Cable Type

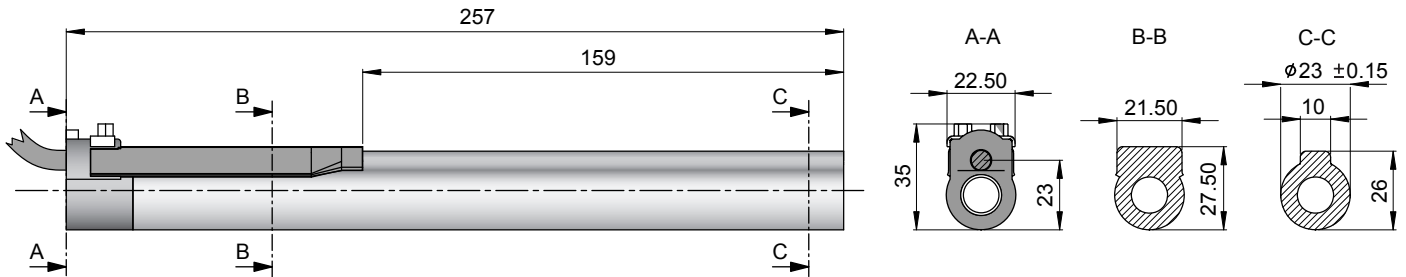

Linear Motor		Stator		Slider	
Type	Art.No	Type	Art. No.	Type	Art No.
P01-23x160/200x340-D100	-->	PS01-23x160-D100	0150-1202	& PL01-12x420/370	0150-1324
P01-23x160/200x340-R20	-->	PS01-23x160-R20	0150-1242	& PL01-12x420/370	0150-1324
P01-23x160F/200x340-R20	-->	PS01-23x160F-R20	0150-1243	& PL01-12x420/370	0150-1324

Slider

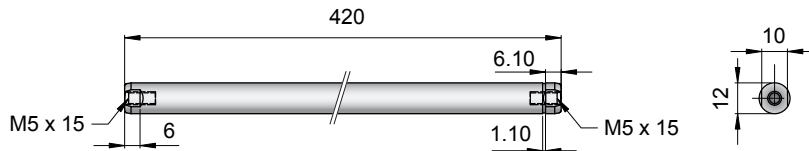

Standard Type		Slider Standard		PL01-12x420/370	
Special Sliders		Heavy Duty Slider with WC/C-Coating		PL02-12x420/370	
		Hollow Slider hole diameter 4.2mm		PL01-12x420/370-L	
					0150-1324
					0150-1325
					0150-1394

Connectors

Motor Connector Wiring

Cable Length:
P01-23x160... 1.0m
P01-23x160...-R20 0.2m

		P01-23...-R	P01-23...-R20	P01-23...
Ph 1+	red	1	1	
Ph 1-	pink	2	6	
Ph 2+	blue	3	2	
Ph 2-	grey	4	7	
+5VDC	white	A	3	
GND	inner Shield	B	8	
Sine	yellow	C	4	
Cosine	green	D	9	
Temp.	black	E	5	
Shield	outer Shield	Case	Case	

Accessoires

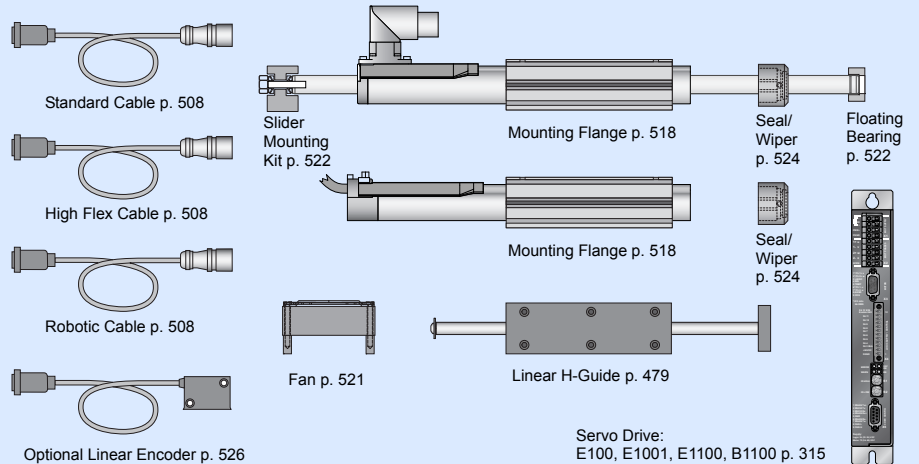

Max. Stroke: 400mm
Peak Force: 86N

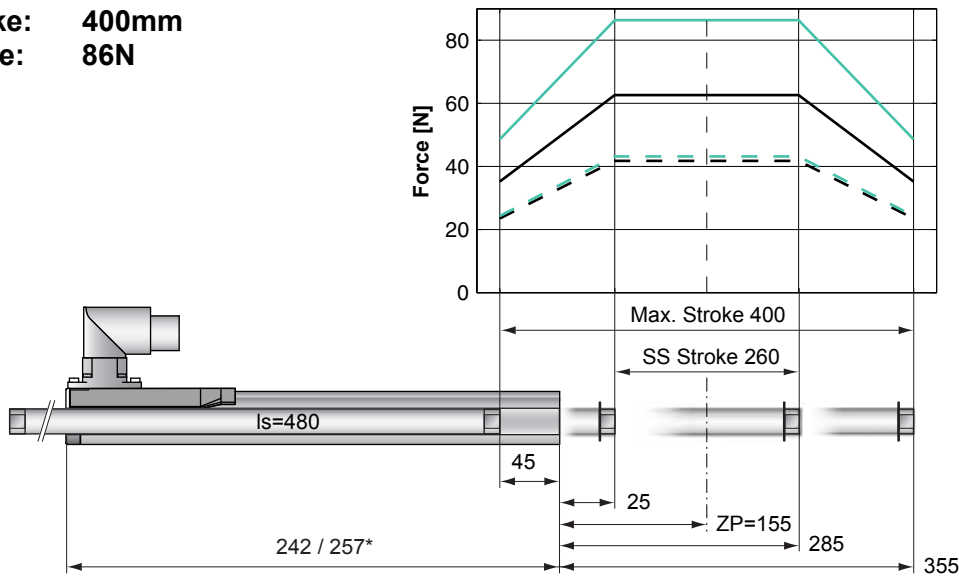

Standard Winding:
 — E1100, 72VDC & E1001, 72VDC
 - - - E100, 48VDC

Fast Winding:
 — E1100, 72VDC & E1001, 72VDC
 - - - E100, 48VDC

Dimensions in mm
 *Cable Type

Motor Specification

	P01-	Connector Type		Cable Type	
		Standard Winding 23x160/260x400-R	Fast Winding 23x160F/260x400-R	Standard Winding 23x160/260x400-D100 23x160/260x400-R20	Fast Winding 23x160F/260x400-R20
Extended Stroke ES	mm (in)	400 (15.75)	400 (15.75)	400 (15.75)	400 (15.75)
Standard Stroke SS	mm (in)	260 (10.24)	260 (10.24)	260 (10.24)	260 (10.24)
Peak Force E1100 / E1001	N (lbf)	63 (14.1)	86 (19.4)	63 (14.1)	86 (19.4)
Peak Force E100	N (lbf)	42 (9.4)	43 (9.7)	42 (9.4)	43 (9.7)
Cont. Force	N (lbf)	17 (3.7)	17 (3.7)	17 (3.7)	17 (3.7)
Cont. Force Fan cooling	N (lbf)	31 (7.1)	32 (7.1)	31 (7.1)	32 (7.1)
Border Force	%	56	56	56	56
Force Constant	N/A (lbf/A)	22.1 (4.96)	14.4 (3.24)	22.1 (4.96)	14.4 (3.24)
Max. Current @ 72VDC	A	2.8	6.0	2.8	6.0
Max. Current @ 48VDC	A	1.9	4.3	1.9	4.3
Max. Velocity @ 72VDC	m/s (in/s)	3.0 (118)	4.6 (181)	3.0 (118)	4.6 (181)
Max. Velocity @ 48VDC	m/s (in/s)	2.0 (79)	3.1 (121)	2.0 (79)	3.1 (121)
Phase Resist. 25/80 °C	Ohm	20.6/24.9	9.0/10.9	20.6/24.9	9.0/10.9
Phase Inductance	mH	2.7	1.2	2.7	1.2
Thermal Resistance	°K/W	3.9	3.8	3.9	3.8
Thermal Time Const.	sec	1900	1800	1900	1800
Stator Diameter	mm (in)	23 (0.91)	23 (0.91)	23 (0.91)	23 (0.91)
Stator Length	mm (in)	242 (9.53)	242 (9.53)	257 (10.12)	257 (10.12)
Stator Mass	g (lb)	450 (0.99)	450 (0.99)	450 (0.99)	450 (0.99)
Slider Diameter	mm (in)	12 (0.47)	12 (0.47)	12 (0.47)	12 (0.47)
Slider Length	mm (in)	480 (18.90)	480 (18.90)	480 (18.90)	480 (18.90)
Slider Mass	g (lb)	380 (0.84)	380 (0.84)	380 (0.84)	380 (0.84)
Position Repeatability	mm (in)	±0.05 (±0.0020)	±0.05 (±0.0020)	±0.05 (±0.0020)	±0.05 (±0.0020)
Linearity	%	±0.25	±0.25	±0.25	±0.25
Repeatability with EPS	mm (in)	±0.01 (±0.0004)	±0.01 (±0.0004)	±0.01 (±0.0004)	±0.01 (±0.0004)
Linearity with EPS	mm (in)	±0.01 (±0.0004)	±0.01 (±0.0004)	±0.01 (±0.0004)	±0.01 (±0.0004)

Position-Time Diagram

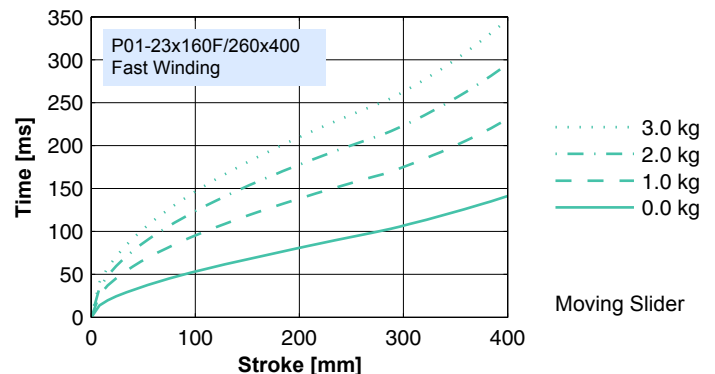
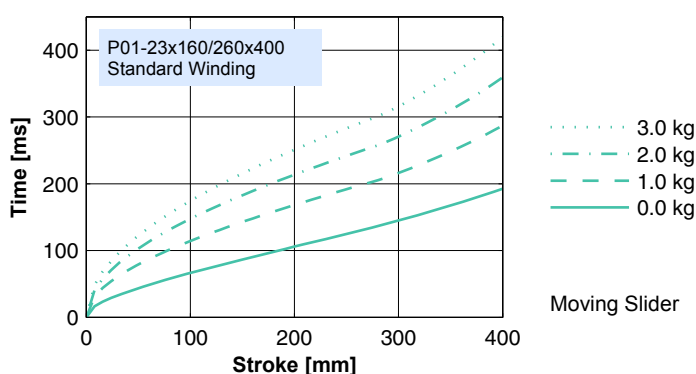

Connector Type

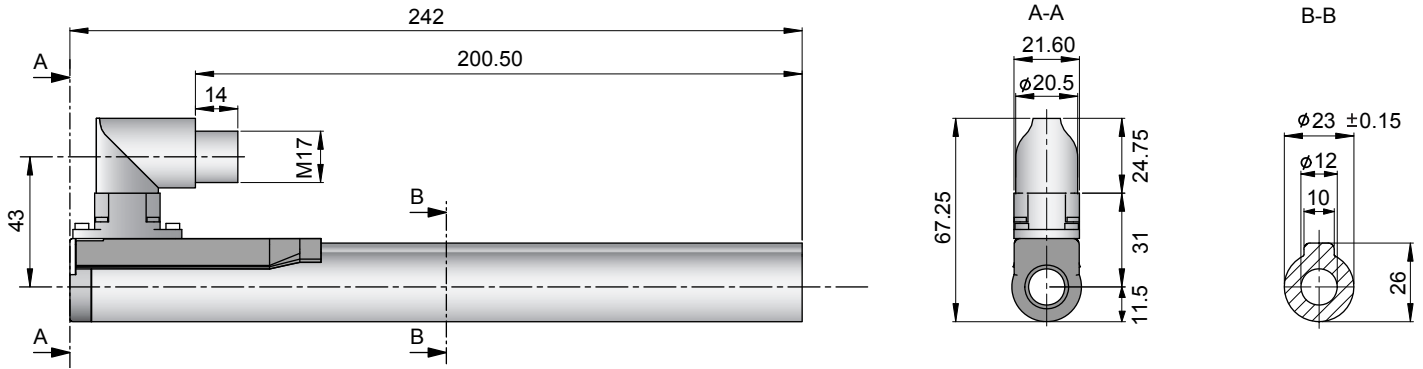

Linear Motor		Stator		Slider	
Type	Art.No	Type	Art. No.	Type	Art No.
P01-23x160/260x400-R	-->	PS01-23x160-R	0150-1234	& PL01-12x480/430	0150-1372
P01-23x160F/260x400-R	-->	PS01-23x160F-R	0150-1235	& PL01-12x480/430	0150-1372

Cable Type

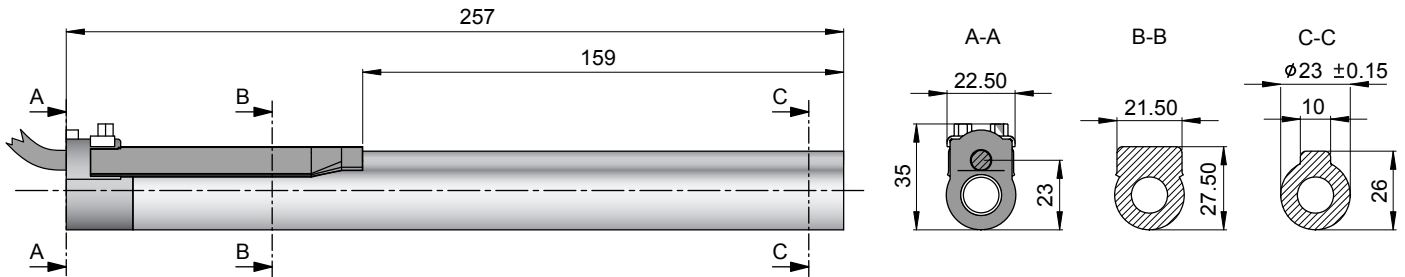

Linear Motor		Stator		Slider	
Type	Art.No	Type	Art. No.	Type	Art No.
P01-23x160/260x400-D100	-->	PS01-23x160-D100	0150-1202	& PL01-12x480/430	0150-1372
P01-23x160/260x400-R20	-->	PS01-23x160-R20	0150-1242	& PL01-12x480/430	0150-1372
P01-23x160F/260x400-R20	-->	PS01-23x160F-R20	0150-1243	& PL01-12x480/430	0150-1372

Slider

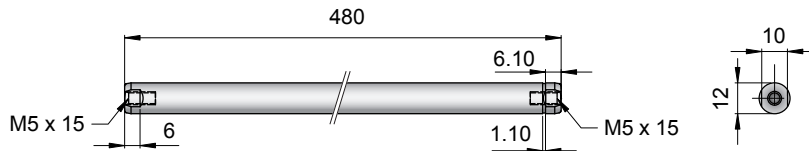

Standard Type	Slider Standard	PL01-12x480/430	0150-1372
Special Sliders	Heavy Duty Slider with WC/C-Coating	PL02-12x480/430	0150-1373
	Hollow Slider hole diameter 4.2mm	PL01-12x480/430-L	on request

Connectors

Motor Connector Wiring

Cable Length:
P01-23x160... 1.0m
P01-23x160...-R20 0.2m

		P01-23...-R	P01-23...-R20	P01-23...
Ph 1+	red	1	1	
Ph 1-	pink	2	6	
Ph 2+	blue	3	2	
Ph 2-	grey	4	7	
+5VDC	white	A	3	
GND	inner Shield	B	8	
Sine	yellow	C	4	
Cosine	green	D	9	
Temp.	black	E	5	
Shield	outer Shield	Case	Case	

Accessoires

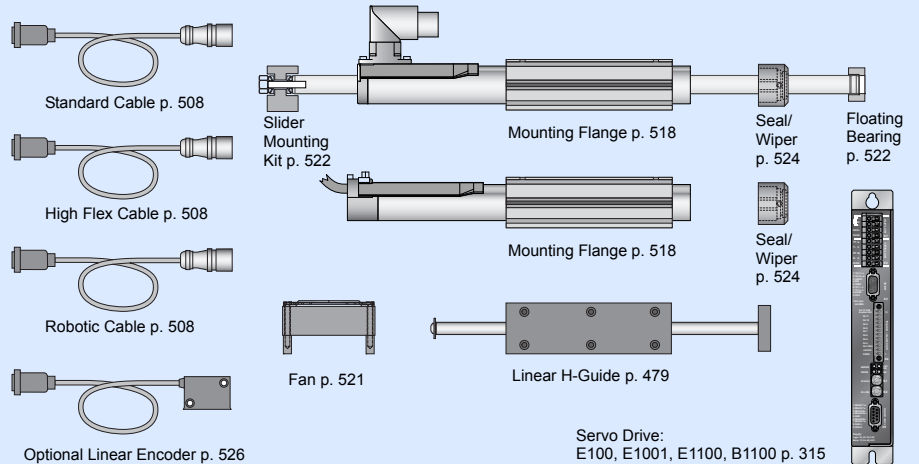

Max. Stroke: 500mm
Peak Force: 86N

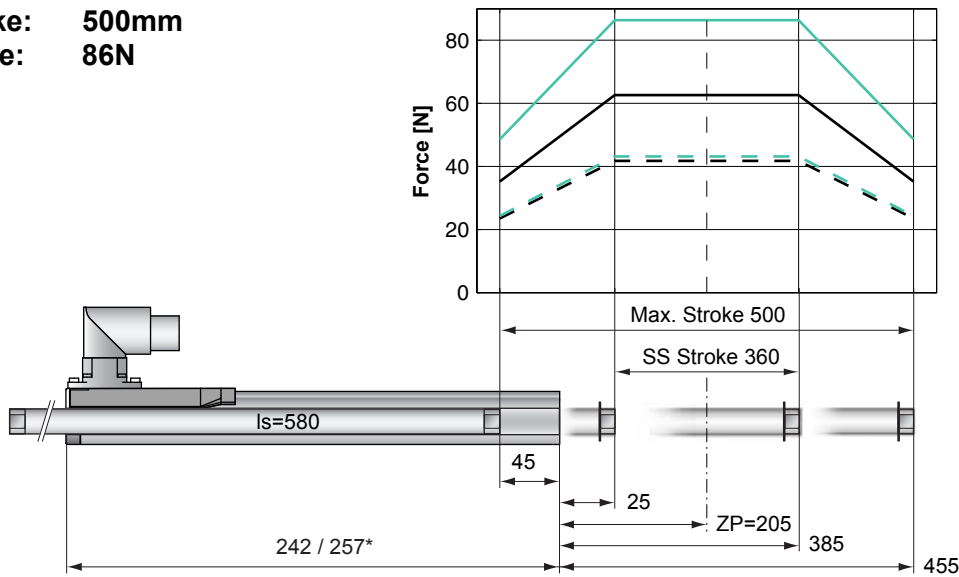

Dimensions in mm
 *Cable Type

Motor Specification

	P01-	Connector Type		Cable Type	
		Standard Winding 23x160/360x500-R	Fast Winding 23x160F/360x500-R	Standard Winding 23x160/360x500-D100 23x160/360x500-R20	Fast Winding 23x160F/360x500-R20
Extended Stroke ES	mm (in)	500 (19.69)	500 (19.69)	500 (19.69)	500 (19.69)
Standard Stroke SS	mm (in)	360 (14.17)	360 (14.17)	360 (14.17)	360 (14.17)
Peak Force E1100 / E1001	N (lbf)	63 (14.1)	86 (19.4)	63 (14.1)	86 (19.4)
Peak Force E100	N (lbf)	42 (9.4)	43 (9.7)	42 (9.4)	43 (9.7)
Cont. Force	N (lbf)	17 (3.7)	17 (3.7)	17 (3.7)	17 (3.7)
Cont. Force Fan cooling	N (lbf)	31 (7.1)	32 (7.1)	31 (7.1)	32 (7.1)
Border Force	%	56	56	56	56
Force Constant	N/A (lbf/A)	22.1 (4.96)	14.4 (3.24)	22.1 (4.96)	14.4 (3.24)
Max. Current @ 72VDC	A	2.8	6.0	2.8	6.0
Max. Current @ 48VDC	A	1.9	4.3	1.9	4.3
Max. Velocity @ 72VDC	m/s (in/s)	3.0 (118)	4.6 (181)	3.0 (118)	4.6 (181)
Max. Velocity @ 48VDC	m/s (in/s)	2.0 (79)	3.1 (121)	2.0 (79)	3.1 (121)
Phase Resist. 25/80 °C	Ohm	20.6/24.9	9.0/10.9	20.6/24.9	9.0/10.9
Phase Inductance	mH	2.7	1.2	2.7	1.2
Thermal Resistance	°K/W	3.9	3.8	3.9	3.8
Thermal Time Const.	sec	1900	1800	1900	1800
Stator Diameter	mm (in)	23 (0.91)	23 (0.91)	23 (0.91)	23 (0.91)
Stator Length	mm (in)	242 (9.53)	242 (9.53)	257 (10.12)	257 (10.12)
Stator Mass	g (lb)	450 (0.99)	450 (0.99)	450 (0.99)	450 (0.99)
Slider Diameter	mm (in)	12 (0.47)	12 (0.47)	12 (0.47)	12 (0.47)
Slider Length	mm (in)	580 (22.83)	580 (22.83)	580 (22.83)	580 (22.83)
Slider Mass	g (lb)	465 (1.03)	465 (1.03)	465 (1.03)	465 (1.03)
Position Repeatability	mm (in)	±0.05 (±0.0020)	±0.05 (±0.0020)	±0.05 (±0.0020)	±0.05 (±0.0020)
Linearity	%	±0.20	±0.20	±0.20	±0.20
Repeatability with EPS	mm (in)	±0.01 (±0.0004)	±0.01 (±0.0004)	±0.01 (±0.0004)	±0.01 (±0.0004)
Linearity with EPS	mm (in)	±0.01 (±0.0004)	±0.01 (±0.0004)	±0.01 (±0.0004)	±0.01 (±0.0004)

Position-Time Diagram

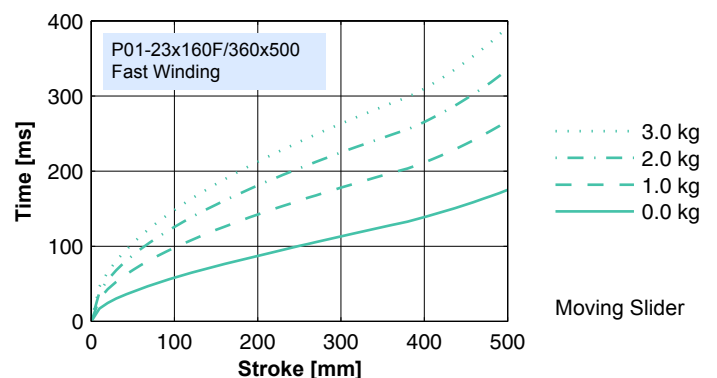
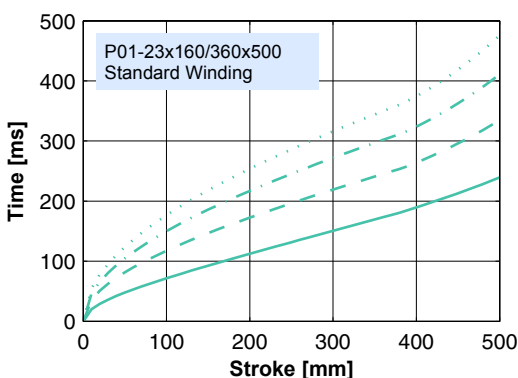

Connector Type

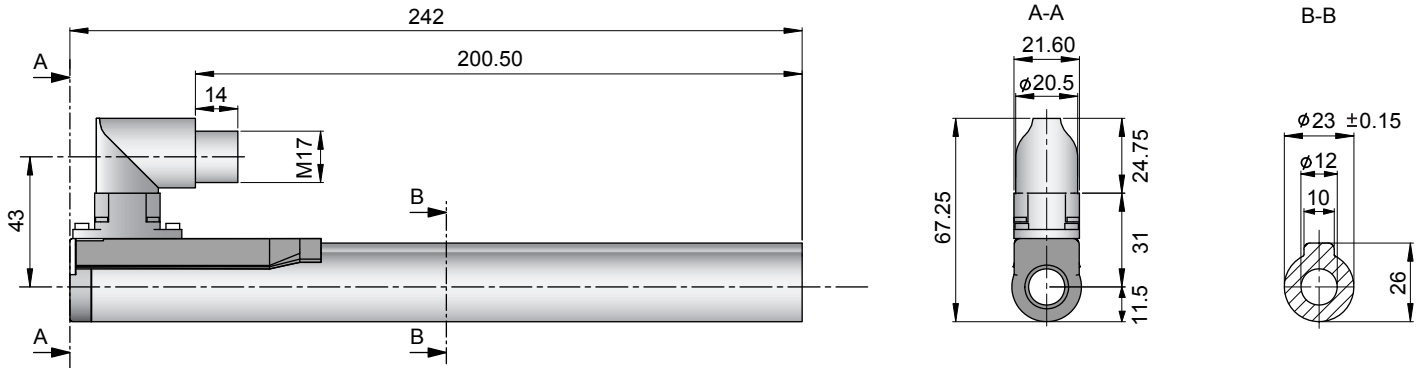

Linear Motor		Stator		Slider		
Type	Art.No	Type	Art. No.	Type	Art No.	
P01-23x160/360x500-R	-->	PS01-23x160-R	0150-1234	&	PL01-12x580/530	0150-1355
P01-23x160F/360x500-R	-->	PS01-23x160F-R	0150-1235	&	PL01-12x580/530	0150-1355

Cable Type

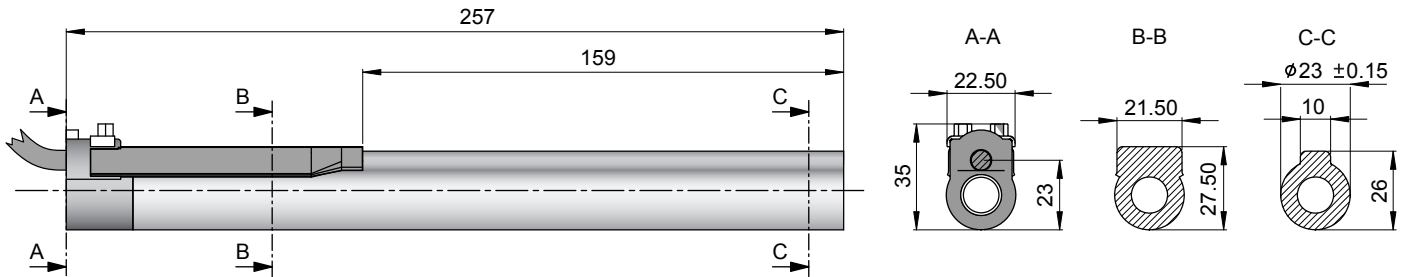

Linear Motor		Stator		Slider		
Type	Art.No	Type	Art. No.	Type	Art No.	
P01-23x160/360x500-D100	-->	PS01-23x160-D100	0150-1202	&	PL01-12x580/530	0150-1355
P01-23x160/360x500-R20	-->	PS01-23x160-R20	0150-1242	&	PL01-12x580/530	0150-1355
P01-23x160F/360x500-R20	-->	PS01-23x160F-R20	0150-1243	&	PL01-12x580/530	0150-1355

Slider

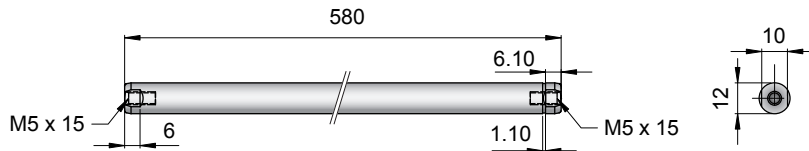

Standard Type	Slider Standard	PL01-12x580/530	0150-1355
Special Sliders	Heavy Duty Slider with WC/C-Coating	PL02-12x580/530	0150-1356
	Hollow Slider hole diameter 4.2mm	PL01-12x580/530-L	0150-1391

Connectors

Motor Connector Wiring

Cable Length:
P01-23x160... 1.0m
P01-23x160...-R20 0.2m

		P01-23...-R	P01-23...-R20	P01-23...
Ph 1+	red	1	1	
Ph 1-	pink	2	6	
Ph 2+	blue	3	2	
Ph 2-	grey	4	7	
+5VDC	white	A	3	
GND	inner Shield	B	8	
Sine	yellow	C	4	
Cosine	green	D	9	
Temp.	black	E	5	
Shield	outer Shield	Case	Case	

Accessoires

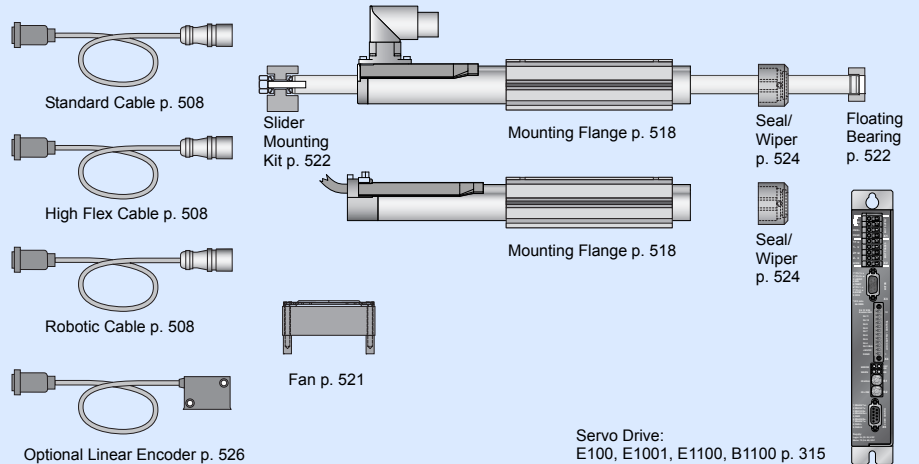

Max. Stroke: 680mm
Peak Force: 86N

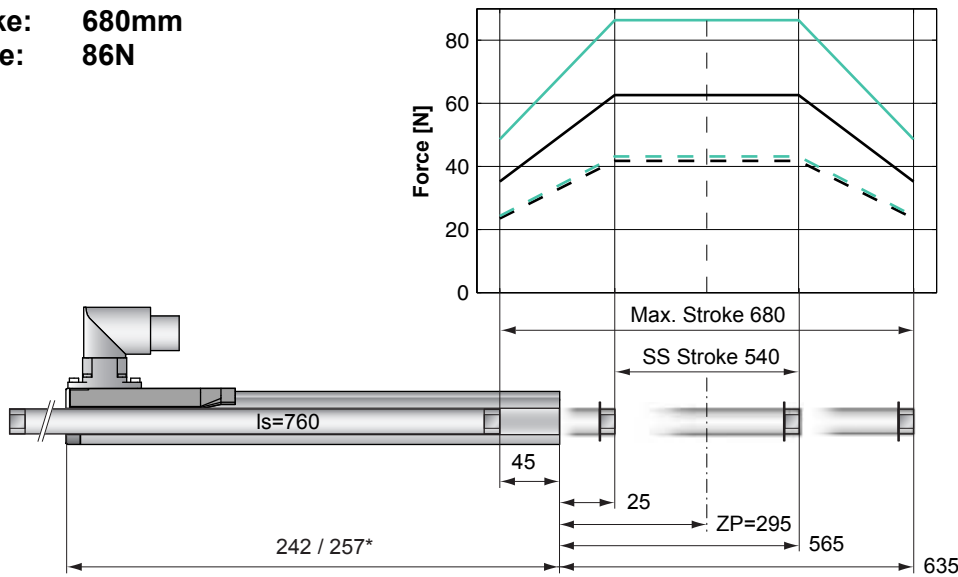

Dimensions in mm
 *Cable Type

Motor Specification

	P01-	Connector Type		Cable Type	
		Standard Winding 23x160/540x680-R	Fast Winding 23x160F/540x680-R	Standard Winding 23x160/540x680-D100 23x160/540x680-R20	Fast Winding 23x160F/540x680-R20
Extended Stroke ES	mm (in)	680 (26.77)	680 (26.77)	680 (26.77)	680 (26.77)
Standard Stroke SS	mm (in)	540 (21.26)	540 (21.26)	540 (21.26)	540 (21.26)
Peak Force E1100 / E1001	N (lbf)	63 (14.1)	86 (19.4)	63 (14.1)	86 (19.4)
Peak Force E100	N (lbf)	42 (9.4)	43 (9.7)	42 (9.4)	43 (9.7)
Cont. Force	N (lbf)	17 (3.7)	17 (3.7)	17 (3.7)	17 (3.7)
Cont. Force Fan cooling	N (lbf)	31 (7.1)	32 (7.1)	31 (7.1)	32 (7.1)
Border Force	%	56	56	56	56
Force Constant	N/A (lbf/A)	22.1 (4.96)	14.4 (3.24)	22.1 (4.96)	14.4 (3.24)
Max. Current @ 72VDC	A	2.8	6.0	2.8	6.0
Max. Current @ 48VDC	A	1.9	4.3	1.9	4.3
Max. Velocity @ 72VDC	m/s (in/s)	3.0 (118)	4.6 (181)	3.0 (118)	4.6 (181)
Max. Velocity @ 48VDC	m/s (in/s)	2.0 (79)	3.1 (121)	2.0 (79)	3.1 (121)
Phase Resist. 25/80 °C	Ohm	20.6/24.9	9.0/10.9	20.6/24.9	9.0/10.9
Phase Inductance	mH	2.7	1.2	2.7	1.2
Thermal Resistance	°K/W	3.9	3.8	3.9	3.8
Thermal Time Const.	sec	1900	1800	1900	1800
Stator Diameter	mm (in)	23 (0.91)	23 (0.91)	23 (0.91)	23 (0.91)
Stator Length	mm (in)	242 (9.53)	242 (9.53)	257 (10.12)	257 (10.12)
Stator Mass	g (lb)	450 (0.99)	450 (0.99)	450 (0.99)	450 (0.99)
Slider Diameter	mm (in)	12 (0.47)	12 (0.47)	12 (0.47)	12 (0.47)
Slider Length	mm (in)	760 (29.92)	760 (29.92)	760 (29.92)	760 (29.92)
Slider Mass	g (lb)	615 (1.36)	615 (1.36)	615 (1.36)	615 (1.36)
Position Repeatability	mm (in)	±0.05 (±0.0020)	±0.05 (±0.0020)	±0.05 (±0.0020)	±0.05 (±0.0020)
Linearity	%	±0.20	±0.20	±0.20	±0.20
Repeatability with EPS	mm (in)	±0.01 (±0.0004)	±0.01 (±0.0004)	±0.01 (±0.0004)	±0.01 (±0.0004)
Linearity with EPS	mm (in)	±0.01 (±0.0004)	±0.01 (±0.0004)	±0.01 (±0.0004)	±0.01 (±0.0004)

Position-Time Diagram

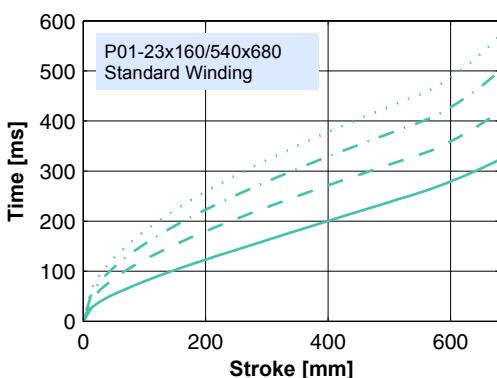

3.0 kg
 2.0 kg
 1.0 kg
 0.0 kg

Moving Slider

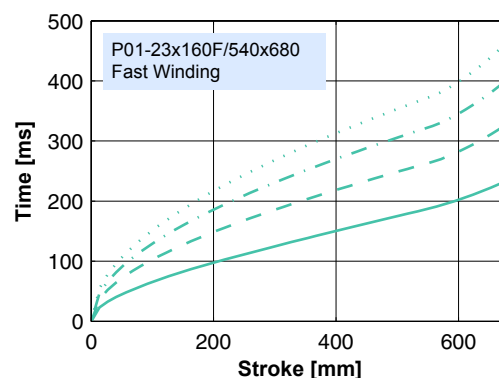

3.0 kg
 2.0 kg
 1.0 kg
 0.0 kg

Moving Slider

Connector Type

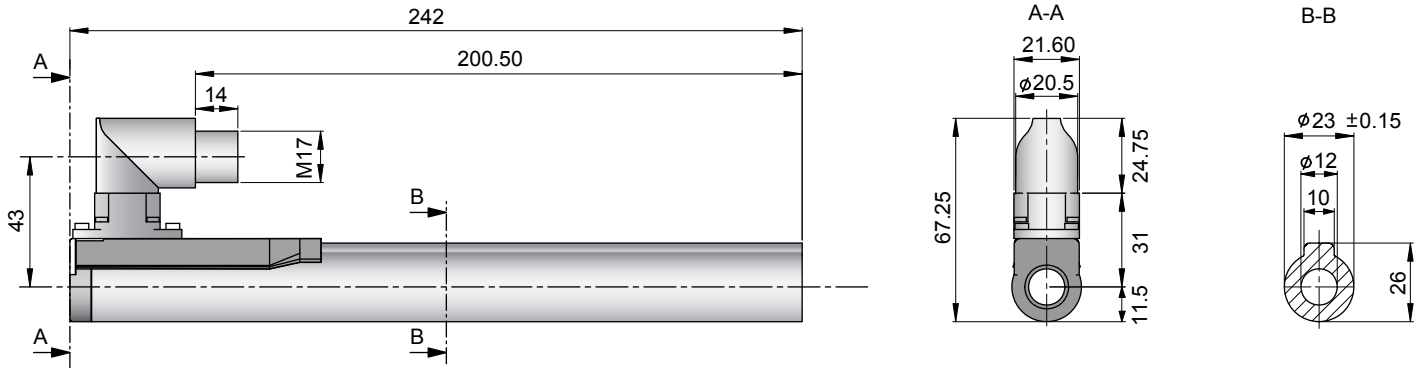

Linear Motor		Stator		Slider	
Type	Art.No	Type	Art. No.	Type	Art No.
P01-23x160/540x680-R	-->	PS01-23x160-R	0150-1234	& PL01-12x760/710	0150-1366
P01-23x160F/540x680-R	-->	PS01-23x160F-R	0150-1235	& PL01-12x760/710	0150-1366

Cable Type

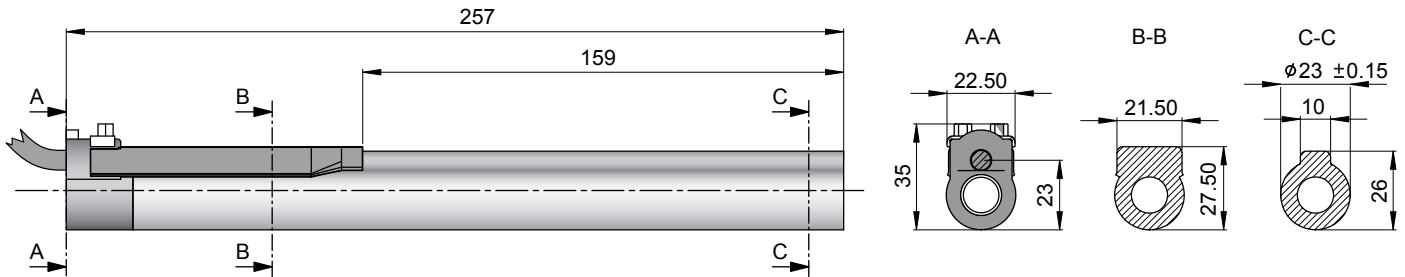

Linear Motor		Stator		Slider	
Type	Art.No	Type	Art. No.	Type	Art No.
P01-23x160/540x680-D100	-->	PS01-23x160-D100	0150-1202	& PL01-12x760/710	0150-1366
P01-23x160/540x680-R20	-->	PS01-23x160-R20	0150-1242	& PL01-12x760/710	0150-1366
P01-23x160F/540x680-R20	-->	PS01-23x160F-R20	0150-1243	& PL01-12x760/710	0150-1366

Slider

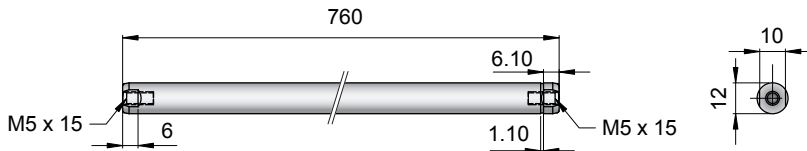

Standard Type		Slider Standard		PL01-12x760/710	
Special Sliders		Heavy Duty Slider with WC/C-Coating		PL02-12x760/710	
		Hollow Slider hole diameter 4.2mm		PL01-12x760/710-L	
					0150-1366
					on request
					0150-1392

Connectors

Motor Connector Wiring

Cable Length:
P01-23x160... 1.0m
P01-23x160...-R20 0.2m

		P01-23...-R	P01-23...-R20	P01-23...
Ph 1+	red	1	1	
Ph 1-	pink	2	6	
Ph 2+	blue	3	2	
Ph 2-	grey	4	7	
+5VDC	white	A	3	
GND	inner Shield	B	8	
Sine	yellow	C	4	
Cosine	green	D	9	
Temp.	black	E	5	
Shield	outer Shield	Case	Case	

Accessoires

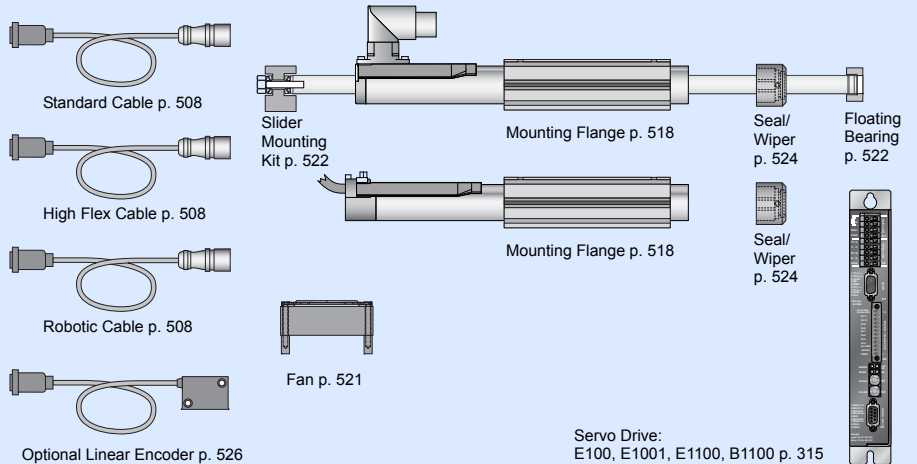

Max. Stroke: 770mm
Peak Force: 86N

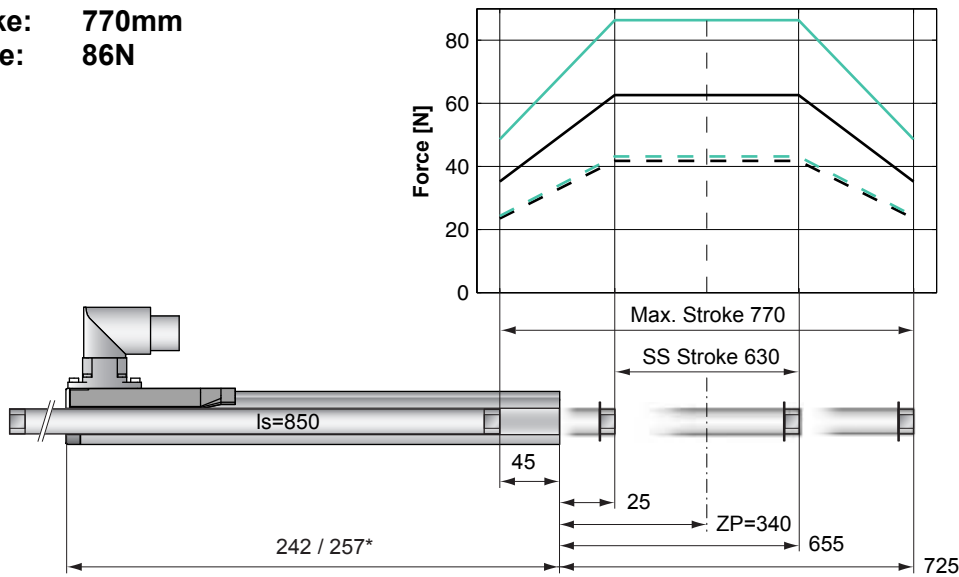

Dimensions in mm
 *Cable Type

Motor Specification

	P01-	Connector Type		Cable Type	
		Standard Winding 23x160/630x770-R	Fast Winding 23x160F/630x770-R	Standard Winding 23x160/630x770-D100 23x160/630x770-R20	Fast Winding 23x160F/630x770-R20
Extended Stroke ES	mm (in)	770 (30.31)	770 (30.31)	770 (30.31)	770 (30.31)
Standard Stroke SS	mm (in)	630 (24.80)	630 (24.80)	630 (24.80)	630 (24.80)
Peak Force E1100 / E1001	N (lbf)	63 (14.1)	86 (19.4)	63 (14.1)	86 (19.4)
Peak Force E100	N (lbf)	42 (9.4)	43 (9.7)	42 (9.4)	43 (9.7)
Cont. Force	N (lbf)	17 (3.7)	17 (3.7)	17 (3.7)	17 (3.7)
Cont. Force Fan cooling	N (lbf)	31 (7.1)	32 (7.1)	31 (7.1)	32 (7.1)
Border Force	%	56	56	56	56
Force Constant	N/A (lbf/A)	22.1 (4.96)	14.4 (3.24)	22.1 (4.96)	14.4 (3.24)
Max. Current @ 72VDC	A	2.8	6.0	2.8	6.0
Max. Current @ 48VDC	A	1.9	4.3	1.9	4.3
Max. Velocity @ 72VDC	m/s (in/s)	3.0 (118)	4.6 (181)	3.0 (118)	4.6 (181)
Max. Velocity @ 48VDC	m/s (in/s)	2.0 (79)	3.1 (121)	2.0 (79)	3.1 (121)
Phase Resist. 25/80 °C	Ohm	20.6/24.9	9.0/10.9	20.6/24.9	9.0/10.9
Phase Inductance	mH	2.7	1.2	2.7	1.2
Thermal Resistance	°K/W	3.9	3.8	3.9	3.8
Thermal Time Const.	sec	1900	1800	1900	1800
Stator Diameter	mm (in)	23 (0.91)	23 (0.91)	23 (0.91)	23 (0.91)
Stator Length	mm (in)	242 (9.53)	242 (9.53)	257 (10.12)	257 (10.12)
Stator Mass	g (lb)	450 (0.99)	450 (0.99)	450 (0.99)	450 (0.99)
Slider Diameter	mm (in)	12 (0.47)	12 (0.47)	12 (0.47)	12 (0.47)
Slider Length	mm (in)	850 (33.46)	850 (33.46)	850 (33.46)	850 (33.46)
Slider Mass	g (lb)	690 (1.52)	690 (1.52)	690 (1.52)	690 (1.52)
Position Repeatability	mm (in)	±0.05 (±0.0020)	±0.05 (±0.0020)	±0.05 (±0.0020)	±0.05 (±0.0020)
Linearity	%	±0.20	±0.20	±0.20	±0.20
Repeatability with EPS	mm (in)	±0.01 (±0.0004)	±0.01 (±0.0004)	±0.01 (±0.0004)	±0.01 (±0.0004)
Linearity with EPS	mm (in)	±0.01 (±0.0004)	±0.01 (±0.0004)	±0.01 (±0.0004)	±0.01 (±0.0004)

Position-Time Diagram

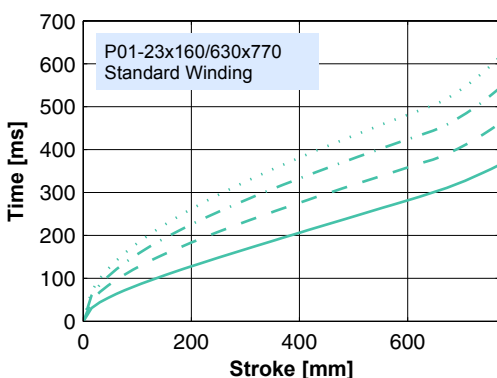

Moving Slider

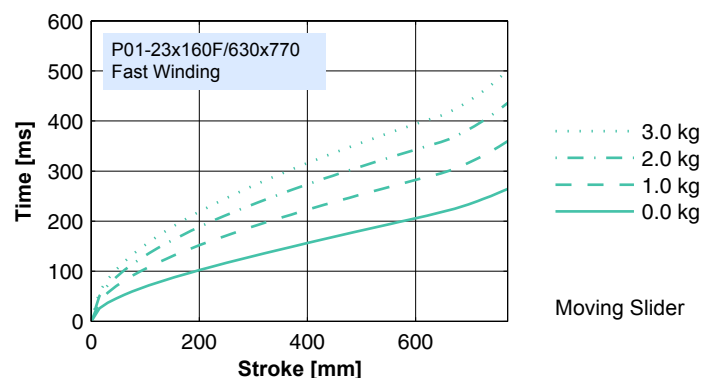

Moving Slider

Connector Type

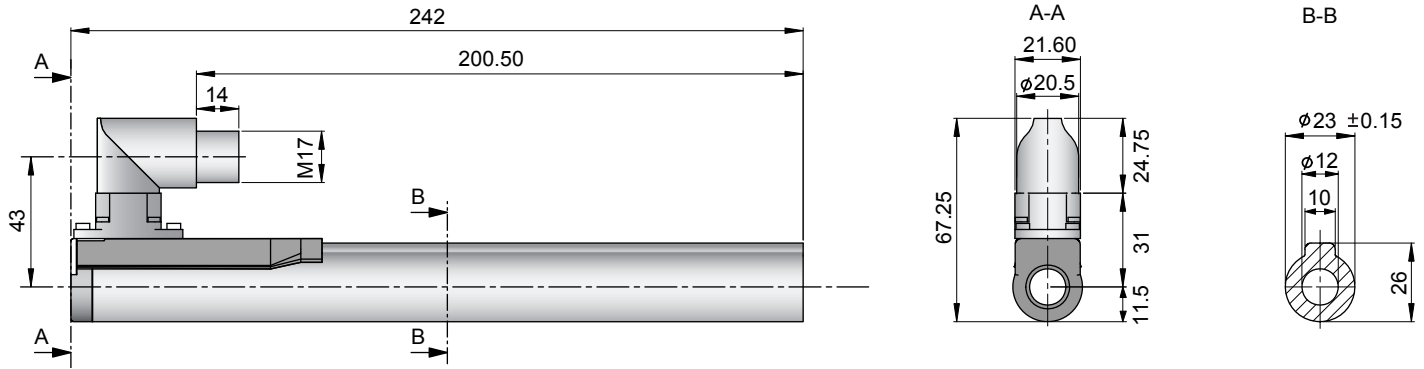

Linear Motor		Stator		Slider	
Type	Art.No	Type	Art. No.	Type	Art No.
P01-23x160/630x770-R	-->	PS01-23x160-R	0150-1234	& PL01-12x850/800	0150-1365
P01-23x160F/630x770-R	-->	PS01-23x160F-R	0150-1235	& PL01-12x850/800	0150-1365

Cable Type

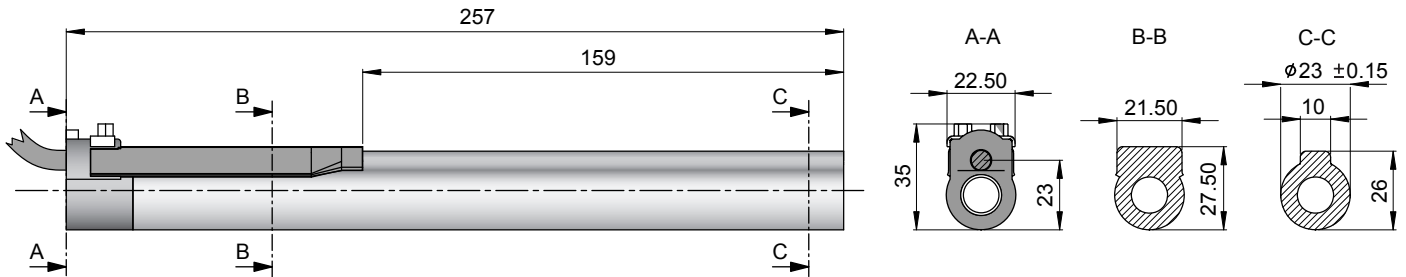

Linear Motor		Stator		Slider	
Type	Art.No	Type	Art. No.	Type	Art No.
P01-23x160/630x770-D100	-->	PS01-23x160-D100	0150-1202	& PL01-12x850/800	0150-1365
P01-23x160/630x770-R20	-->	PS01-23x160-R20	0150-1242	& PL01-12x850/800	0150-1365
P01-23x160F/630x770-R20	-->	PS01-23x160F-R20	0150-1243	& PL01-12x850/800	0150-1365

Slider

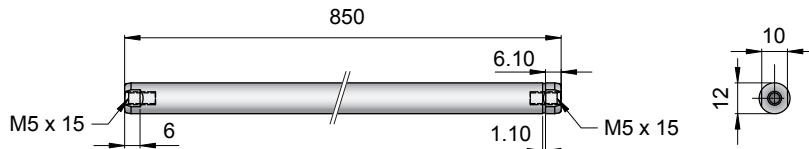

Standard Type	Slider Standard	PL01-12x850/800	0150-1365
Special Sliders	Heavy Duty Slider with WC/C-Coating	PL02-12x850/800	on request
	Hollow Slider hole diameter 4.2mm	PL01-12x850/800-L	on request

Connectors

Motor Connector Wiring

Cable Length:
P01-23x160... 1.0m
P01-23x160...-R20 0.2m

		P01-23...-R	P01-23...-R20	P01-23...
Ph 1+	red	1	1	
Ph 1-	pink	2	6	
Ph 2+	blue	3	2	
Ph 2-	grey	4	7	
+5VDC	white	A	3	
GND	inner Shield	B	8	
Sine	yellow	C	4	
Cosine	green	D	9	
Temp.	black	E	5	
Shield	outer Shield	Case	Case	

Accessoires

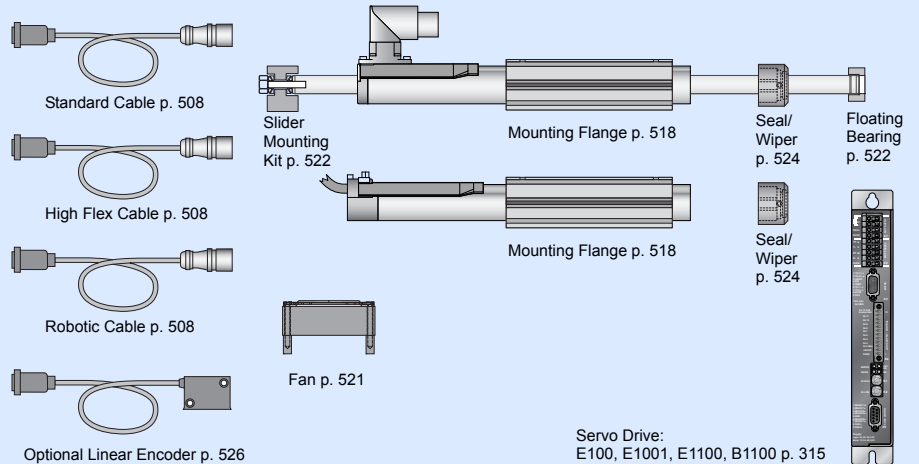



P01-37x120/20x100 86

P01-37x120/80x160 88

P01-37x120/180x260 90

P01-37x120/280x360 92

P01-37x120/380x460 94

P01-37x120/480x560 96

P01-37x120/580x660 98

P01-37x120/680x760 100

P01-37x120/780x860 102

P01-37x120/980x1060 104

P01-37x120/1180x1260 106

P01-37x120/1380x1460 108

Max. Stroke: 100mm
Peak Force: 163N

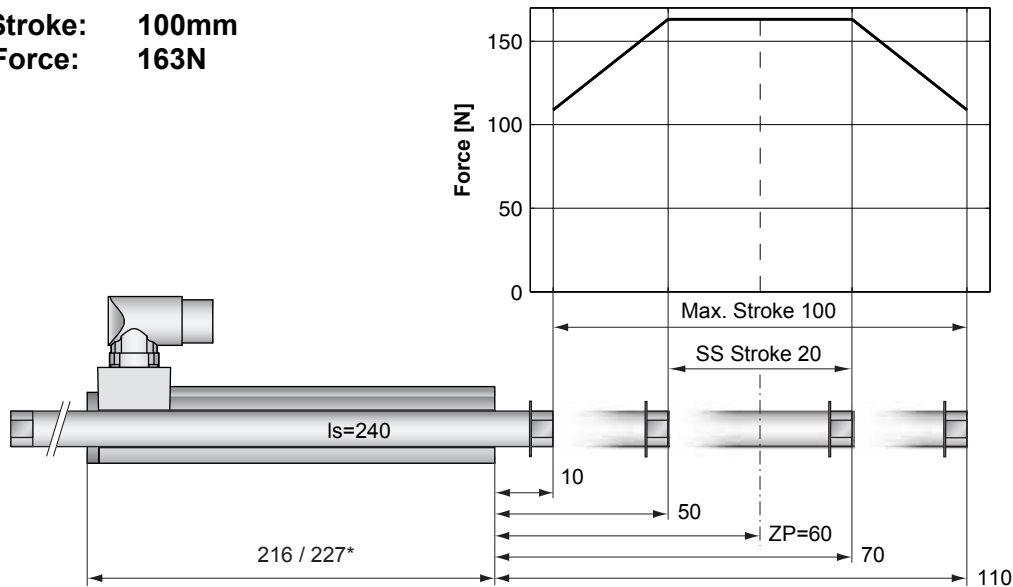

Standard Winding:
 — E1100-HC, 72VDC
 — E1100, 72VDC & E1001, 72VDC

Dimensions in mm
 *Cable Type

Motor Specification

	P01-	Connector Type	Cable Type
		37x120/20x100-C	37x120/20x100-P150 37x120/20x100-C20
Extended Stroke ES	mm (in)	100 (3.94)	100 (3.94)
Standard Stroke SS	mm (in)	20 (0.79)	20 (0.79)
Peak Force E1100-HC	N (lbf)	163 (36.7)	163 (36.7)
Peak Force E1100 / E1001	N (lbf)	163 (36.7)	163 (36.7)
Cont. Force	N (lbf)	29 (6.5)	29 (6.5)
Cont. Force Fan cooling	N (lbf)	54 (12.2)	54 (12.2)
Border Force	%	67	67
Force Constant	N/A (lbf/A)	20.4 (4.59)	20.4 (4.59)
Max. Current @ 72VDC	A	8.0	8.0
Max. Current @ 48VDC	A	6.3	6.3
Max. Velocity @ 72VDC	m/s (in/s)	3.2 (128)	3.2 (128)
Max. Velocity @ 48VDC	m/s (in/s)	2.2 (85)	2.2 (85)
Phase Resist. 25/80 °C	Ohm	6.2/7.5	6.2/7.5
Phase Inductance	mH	3.1	3.1
Thermal Resistance	°K/W	3.6	3.6
Thermal Time Const.	sec	2900	2900
Stator Diameter	mm (in)	37 (1.46)	37 (1.46)
Stator Length	mm (in)	216 (8.50)	227 (8.94)
Stator Mass	g (lb)	740 (1.63)	740 (1.63)
Slider Diameter	mm (in)	20 (0.79)	20 (0.79)
Slider Length	mm (in)	240 (9.45)	240 (9.45)
Slider Mass	g (lb)	460 (1.01)	460 (1.01)
Position Repeatability	mm (in)	±0.05 (±0.0020)	±0.05 (±0.0020)
Linearity	%	±0.40	±0.40
Repeatability with EPS	mm (in)	±0.01 (±0.0004)	±0.01 (±0.0004)
Linearity with EPS	mm (in)	±0.01 (±0.0004)	±0.01 (±0.0004)

Position-Time Diagram

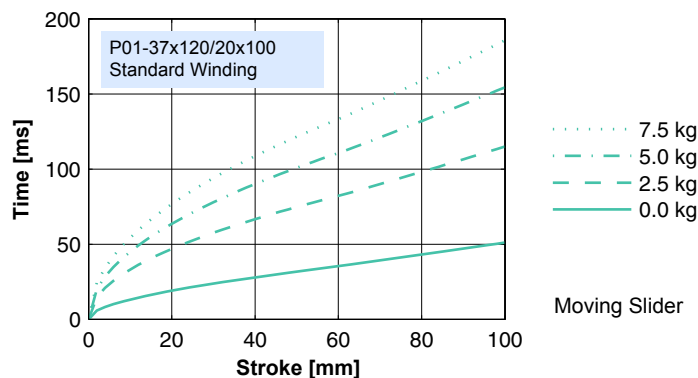

Connector Type

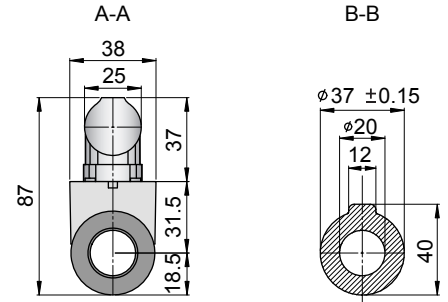
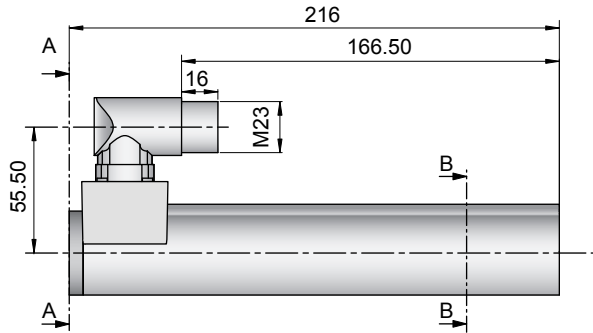

Linear Motor		Stator		Slider	
Type	Art.No	Type	Art. No.	Type	Art. No.
P01-37x120/20x100-C	-->	PS01-37x120-C	0150-1223	& PL01-20x240/160	0150-1346

Cable Type

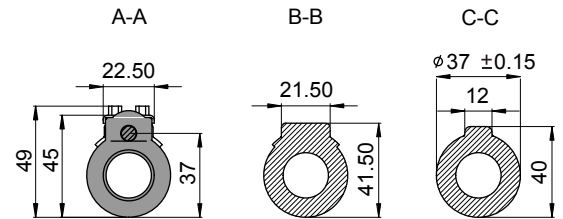
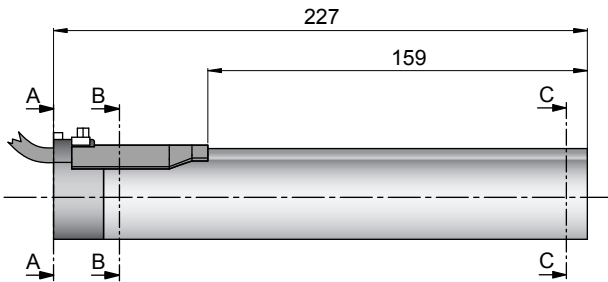

Linear Motor		Stator		Slider	
Type	Art.No	Type	Art. No.	Type	Art. No.
P01-37x120/20x100-P150	-->	PS01-37x120-P150	0150-1204	& PL01-20x240/160	0150-1346
P01-37x120/20x100-C20	-->	PS01-37x120-C20	0150-1237	& PL01-20x240/160	0150-1346

Slider

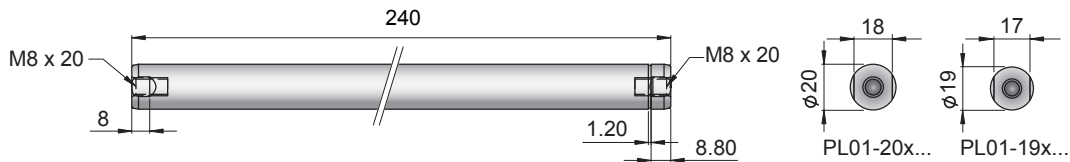

Standard Type	Slider Standard	PL01-20x240/160	0150-1346
Special Sliders	Heavy Duty Slider with WC/C-Coating	PL02-20x240/160	0150-1347
	Hollow Slider hole diameter 6.5mm	PL01-20x240/160-L	0150-1350
	High Clearance Slider d=19mm, m=415g	PL01-19x240/160	0150-1448

Connectors

Motor Connector Wiring

Cable Length:
P01-37x120... 1.5m
P01-37x120...-C20 0.2m

		P01-37...-C P01-37...-C20	P01-37...
Ph 1+	red	A	1
Ph 1-	pink	B	2
Ph 2+	blue	C	3
Ph 2-	grey	D	4
+5VDC	white	E	5
GND	inner Shield	F	6
Sine	yellow	G	7
Cosine	green	H	8
Temp.	black	L	9
Shield	outer Shield	Case	10

Accessoires

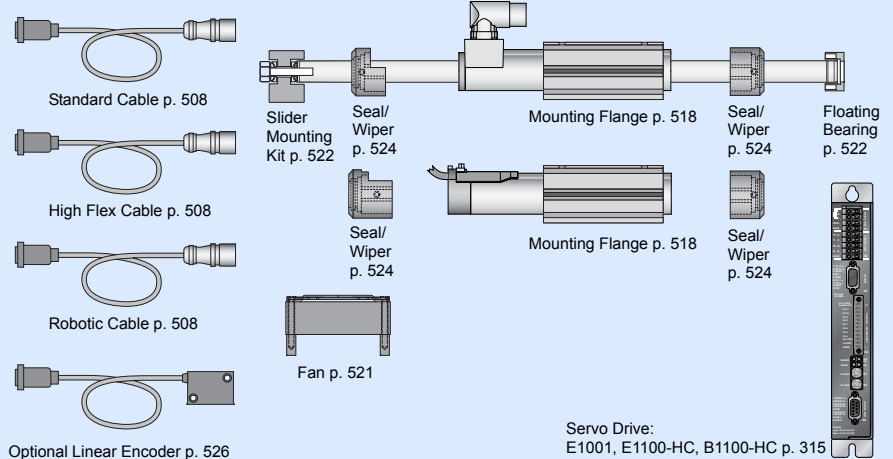

Servo Drive:
E1001, E1100-HC, B1100-HC p. 315

Max. Stroke: 160mm
Peak Force: 163N

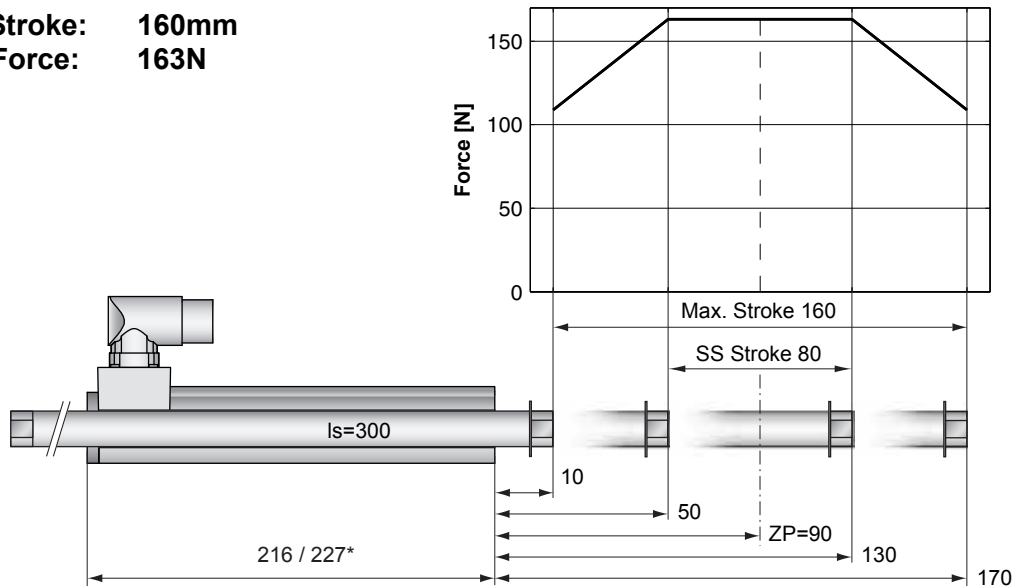

Standard Winding:
 — E1100-HC, 72VDC
 - - E1100, 72VDC & E1001, 72VDC

Dimensions in mm
 *Cable Type

Motor Specification

	P01-	Connector Type	Cable Type
		37x120/80x160-C	37x120/80x160-P150 37x120/80x160-C20
Extended Stroke ES	mm (in)	160 (6.30)	160 (6.30)
Standard Stroke SS	mm (in)	80 (3.15)	80 (3.15)
Peak Force E1100-HC	N (lbf)	163 (36.7)	163 (36.7)
Peak Force E1100 / E1001	N (lbf)	163 (36.7)	163 (36.7)
Cont. Force	N (lbf)	29 (6.5)	29 (6.5)
Cont. Force Fan cooling	N (lbf)	54 (12.2)	54 (12.2)
Border Force	%	67	67
Force Constant	N/A (lbf/A)	20.4 (4.59)	20.4 (4.59)
Max. Current @ 72VDC	A	8.0	8.0
Max. Current @ 48VDC	A	6.3	6.3
Max. Velocity @ 72VDC	m/s (in/s)	3.2 (128)	3.2 (128)
Max. Velocity @ 48VDC	m/s (in/s)	2.2 (85)	2.2 (85)
Phase Resist. 25/80 °C	Ohm	6.2/7.5	6.2/7.5
Phase Inductance	mH	3.1	3.1
Thermal Resistance	°K/W	3.6	3.6
Thermal Time Const.	sec	2900	2900
Stator Diameter	mm (in)	37 (1.46)	37 (1.46)
Stator Length	mm (in)	216 (8.50)	227 (8.94)
Stator Mass	g (lb)	740 (1.63)	740 (1.63)
Slider Diameter	mm (in)	20 (0.79)	20 (0.79)
Slider Length	mm (in)	300 (11.81)	300 (11.81)
Slider Mass	g (lb)	599 (1.32)	599 (1.32)
Position Repeatability	mm (in)	±0.05 (±0.0020)	±0.05 (±0.0020)
Linearity	%	±0.30	±0.30
Repeatability with EPS	mm (in)	±0.01 (±0.0004)	±0.01 (±0.0004)
Linearity with EPS	mm (in)	±0.01 (±0.0004)	±0.01 (±0.0004)

Position-Time Diagram

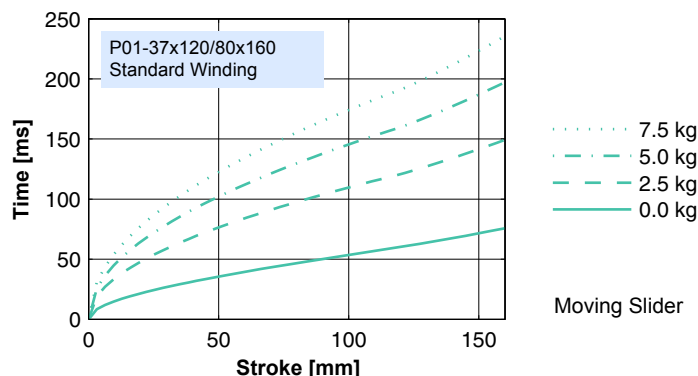

Connector Type

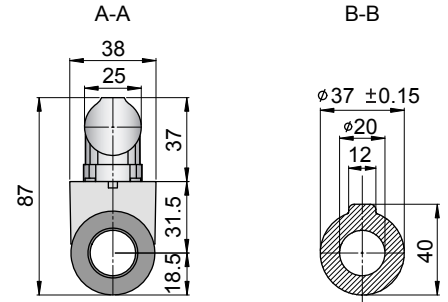
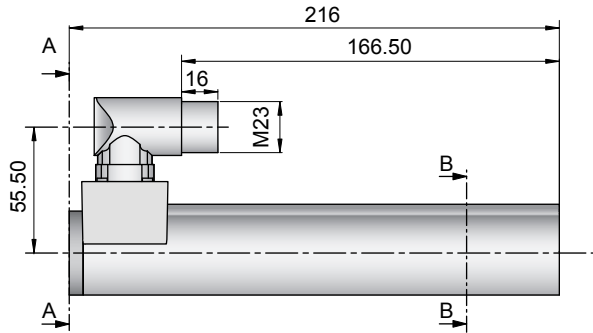

Linear Motor		Stator		Slider	
Type	Art.No	Type	Art. No.	Type	Art. No.
P01-37x120/80x160-C	-->	PS01-37x120-C	0150-1223	& PL01-20x300/220	0150-1348

Cable Type

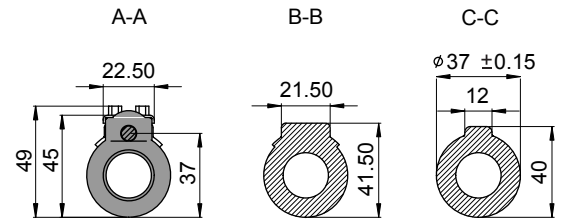
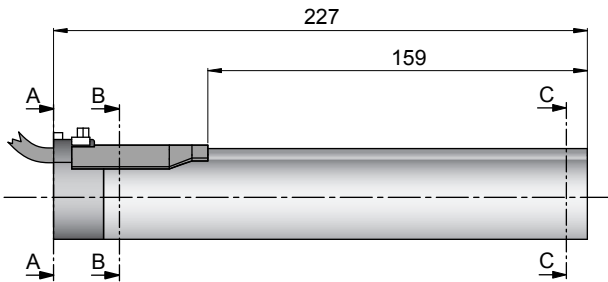

Linear Motor		Stator		Slider	
Type	Art.No	Type	Art. No.	Type	Art. No.
P01-37x120/80x160-P150	-->	PS01-37x120-P150	0150-1204	& PL01-20x300/220	0150-1348
P01-37x120/80x160-C20	-->	PS01-37x120-C20	0150-1237	& PL01-20x300/220	0150-1348

Slider

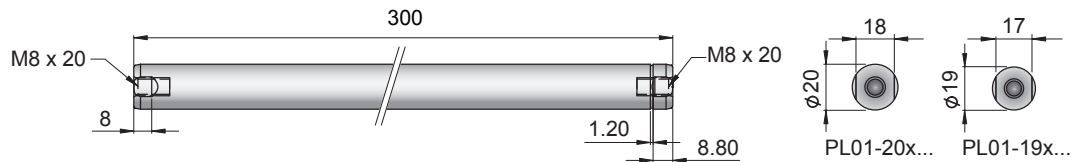

Standard Type	Slider Standard	PL01-20x300/220	0150-1348
Special Sliders	Heavy Duty Slider with WC/C-Coating	PL02-20x300/220	0150-1349
	Hollow Slider hole diameter 6.5mm	PL01-20x300/220-L	0150-1351
	High Clearance Slider d=19mm, m=541g	PL01-19x300/220	0150-1449

Connectors

Motor Connector Wiring

Cable Length:
P01-37x120... 1.5m
P01-37x120...-C20 0.2m

		P01-37...-C P01-37...-C20	P01-37...
Ph 1+	red	A	1
Ph 1-	pink	B	2
Ph 2+	blue	C	3
Ph 2-	grey	D	4
+5VDC	white	E	5
GND	inner Shield	F	6
Sine	yellow	G	7
Cosine	green	H	8
Temp.	black	L	9
Shield	outer Shield	Case	10

Accessoires

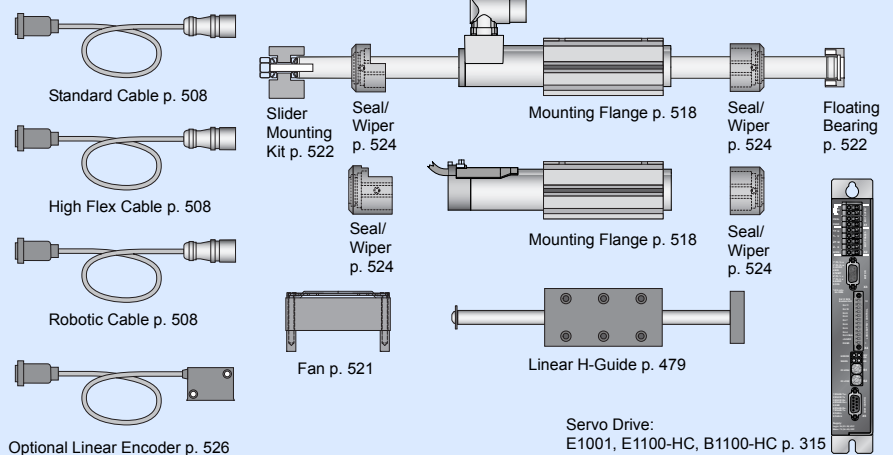

Servo Drive:
E1001, E1100-HC, B1100-HC p. 315

Max. Stroke: 260mm
Peak Force: 163N

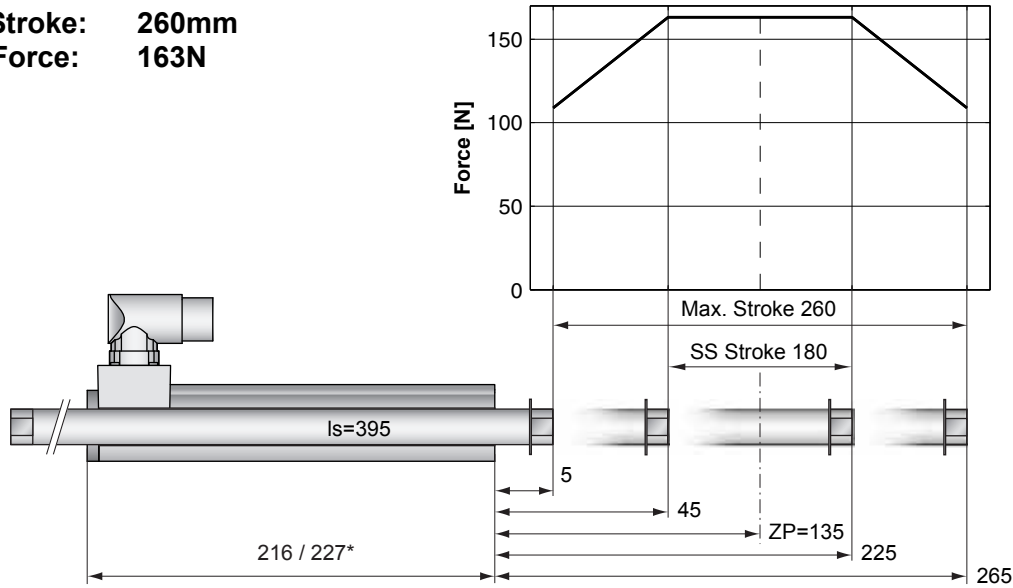

Dimensions in mm
 *Cable Type

Motor Specification

	P01-	Connector Type	Cable Type
		37x120/180x260-C	37x120/180x260-P150 37x120/180x260-C20
Extended Stroke ES	mm (in)	260 (10.24)	260 (10.24)
Standard Stroke SS	mm (in)	180 (7.09)	180 (7.09)
Peak Force E1100-HC	N (lbf)	163 (36.7)	163 (36.7)
Peak Force E1100 / E1001	N (lbf)	163 (36.7)	163 (36.7)
Cont. Force	N (lbf)	29 (6.5)	29 (6.5)
Cont. Force Fan cooling	N (lbf)	54 (12.2)	54 (12.2)
Border Force	%	67	67
Force Constant	N/A (lbf/A)	20.4 (4.59)	20.4 (4.59)
Max. Current @ 72VDC	A	8.0	8.0
Max. Current @ 48VDC	A	6.3	6.3
Max. Velocity @ 72VDC	m/s (in/s)	3.2 (128)	3.2 (128)
Max. Velocity @ 48VDC	m/s (in/s)	2.2 (85)	2.2 (85)
Phase Resist. 25/80 °C	Ohm	6.2/7.5	6.2/7.5
Phase Inductance	mH	3.1	3.1
Thermal Resistance	°K/W	3.6	3.6
Thermal Time Const.	sec	2900	2900
Stator Diameter	mm (in)	37 (1.46)	37 (1.46)
Stator Length	mm (in)	216 (8.50)	227 (8.94)
Stator Mass	g (lb)	740 (1.63)	740 (1.63)
Slider Diameter	mm (in)	20 (0.79)	20 (0.79)
Slider Length	mm (in)	395 (15.55)	395 (15.55)
Slider Mass	g (lb)	829 (1.83)	829 (1.83)
Position Repeatability	mm (in)	±0.05 (±0.0020)	±0.05 (±0.0020)
Linearity	%	±0.20	±0.20
Repeatability with EPS	mm (in)	±0.01 (±0.0004)	±0.01 (±0.0004)
Linearity with EPS	mm (in)	±0.01 (±0.0004)	±0.01 (±0.0004)

Position-Time Diagram

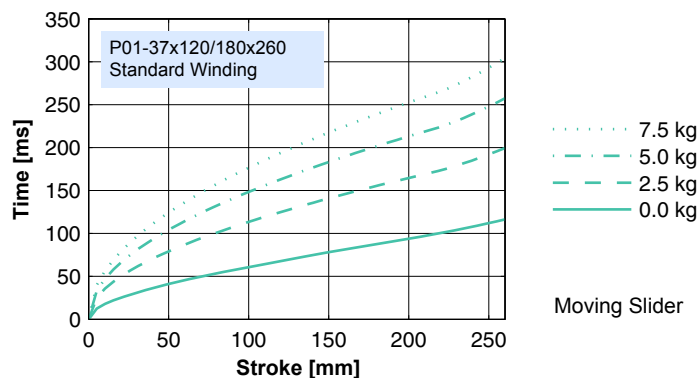

Connector Type

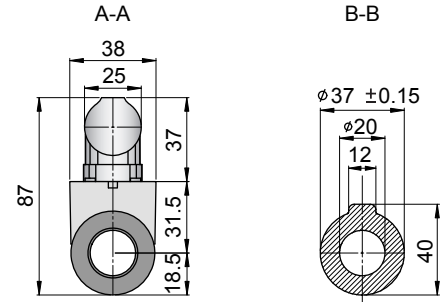
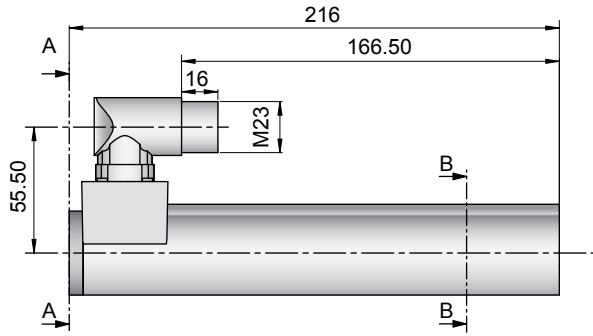

Linear Motor		Stator		Slider	
Type	Art.No	Type	Art. No.	Type	Art. No.
P01-37x120/180x260-C	-->	PS01-37x120-C	0150-1223	& PL01-20x395/320	0150-1318

Cable Type

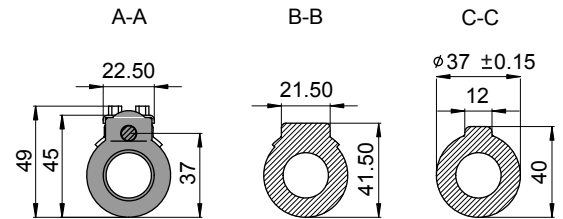
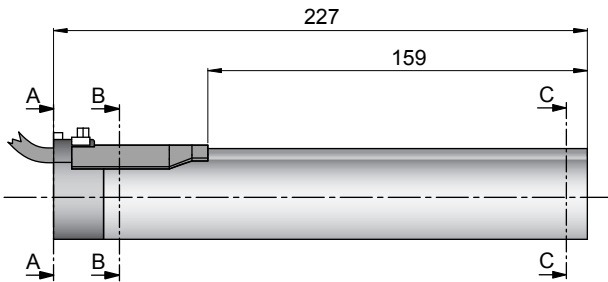

Linear Motor		Stator		Slider	
Type	Art.No	Type	Art. No.	Type	Art. No.
P01-37x120/180x260-P150	-->	PS01-37x120-P150	0150-1204	& PL01-20x395/320	0150-1318
P01-37x120/180x260-C20	-->	PS01-37x120-C20	0150-1237	& PL01-20x395/320	0150-1318

Slider

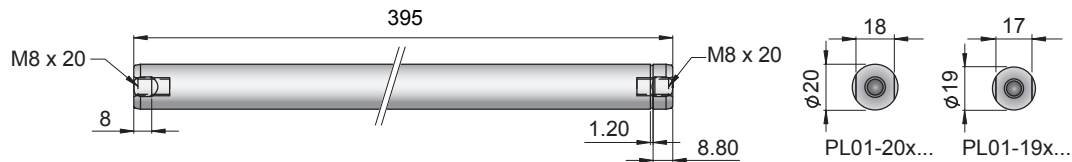

Standard Type	Slider Standard	PL01-20x395/320	0150-1318
Special Sliders	Heavy Duty Slider with WC/C-Coating	PL02-20x395/320	0150-1319
	Hollow Slider hole diameter 6.5mm	PL01-20x395/320-L	0150-1354
	High Clearance Slider d=19mm, m=748g	PL01-19x395/320	0150-1452

Connectors

Motor Connector Wiring

Cable Length:
P01-37x120... 1.5m
P01-37x120...-C20 0.2m

		P01-37...-C P01-37...-C20	P01-37...
Ph 1+	red	A	1
Ph 1-	pink	B	2
Ph 2+	blue	C	3
Ph 2-	grey	D	4
+5VDC	white	E	5
GND	inner Shield	F	6
Sine	yellow	G	7
Cosine	green	H	8
Temp.	black	L	9
Shield	outer Shield	Case	10

Accessoires

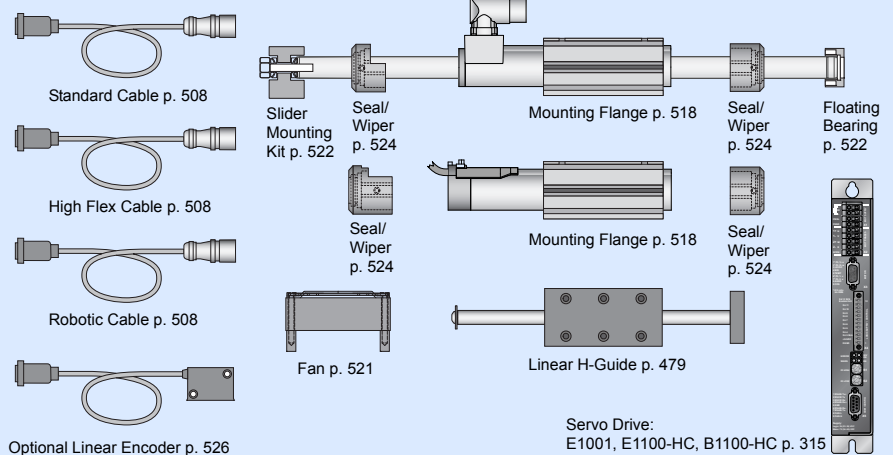

Max. Stroke: 360mm
Peak Force: 163N

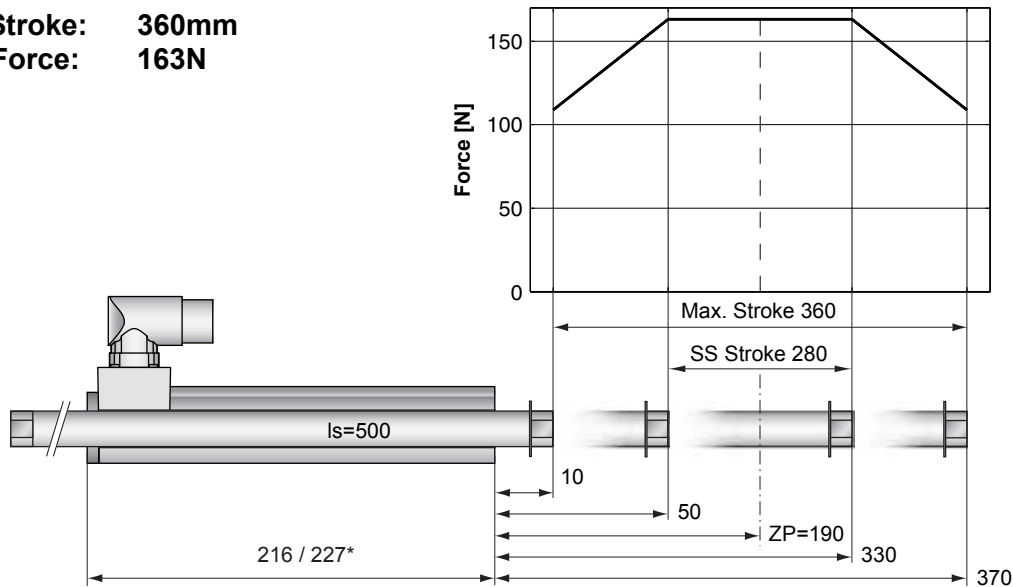

Standard Winding:
 — E1100-HC, 72VDC
 — E1100, 72VDC & E1001, 72VDC

Dimensions in mm
 *Cable Type

Motor Specification

	P01-	Connector Type	Cable Type
		37x120/280x360-C	37x120/280x360-P150 37x120/280x360-C20
Extended Stroke ES	mm (in)	360 (14.17)	360 (14.17)
Standard Stroke SS	mm (in)	280 (11.02)	280 (11.02)
Peak Force E1100-HC	N (lbf)	163 (36.7)	163 (36.7)
Peak Force E1100 / E1001	N (lbf)	163 (36.7)	163 (36.7)
Cont. Force	N (lbf)	29 (6.5)	29 (6.5)
Cont. Force Fan cooling	N (lbf)	54 (12.2)	54 (12.2)
Border Force	%	67	67
Force Constant	N/A (lbf/A)	20.4 (4.59)	20.4 (4.59)
Max. Current @ 72VDC	A	8.0	8.0
Max. Current @ 48VDC	A	6.3	6.3
Max. Velocity @ 72VDC	m/s (in/s)	3.2 (128)	3.2 (128)
Max. Velocity @ 48VDC	m/s (in/s)	2.2 (85)	2.2 (85)
Phase Resist. 25/80 °C	Ohm	6.2/7.5	6.2/7.5
Phase Inductance	mH	3.1	3.1
Thermal Resistance	°K/W	3.6	3.6
Thermal Time Const.	sec	2900	2900
Stator Diameter	mm (in)	37 (1.46)	37 (1.46)
Stator Length	mm (in)	216 (8.50)	227 (8.94)
Stator Mass	g (lb)	740 (1.63)	740 (1.63)
Slider Diameter	mm (in)	20 (0.79)	20 (0.79)
Slider Length	mm (in)	500 (19.69)	500 (19.69)
Slider Mass	g (lb)	1064 (2.35)	1064 (2.35)
Position Repeatability	mm (in)	±0.05 (±0.0020)	±0.05 (±0.0020)
Linearity	%	±0.20	±0.20
Repeatability with EPS	mm (in)	±0.01 (±0.0004)	±0.01 (±0.0004)
Linearity with EPS	mm (in)	±0.01 (±0.0004)	±0.01 (±0.0004)

Position-Time Diagram

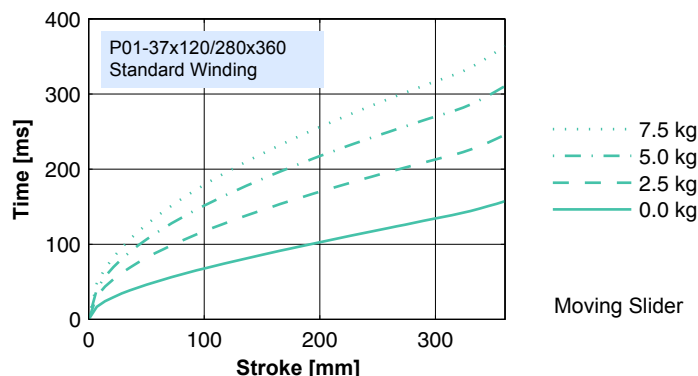

Connector Type

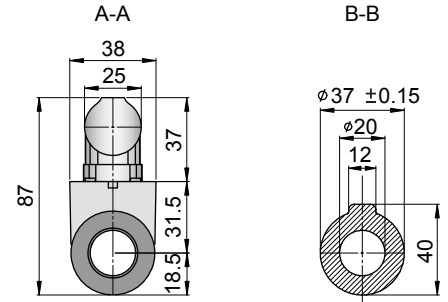
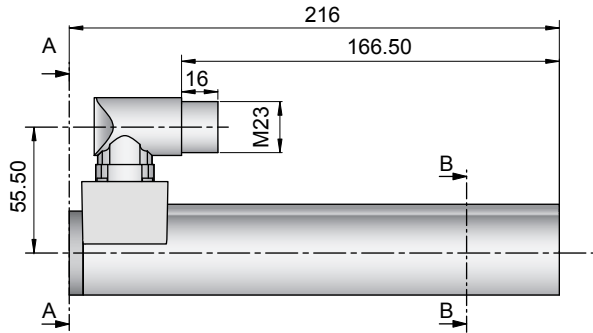

Linear Motor		Stator		Slider	
Type	Art.No	Type	Art. No.	Type	Art. No.
P01-37x120/280x360-C	-->	PS01-37x120-C	0150-1223	& PL01-20x500/420	0150-1328

Cable Type

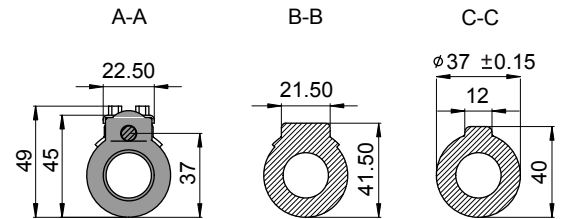
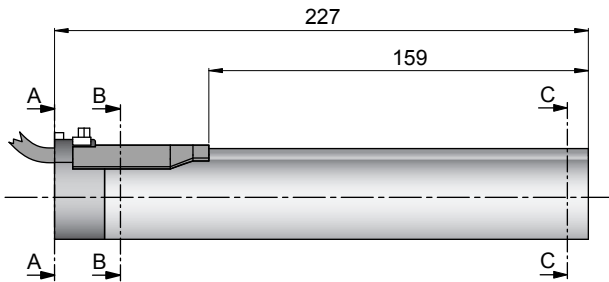

Linear Motor		Stator		Slider	
Type	Art.No	Type	Art. No.	Type	Art. No.
P01-37x120/280x360-P150	-->	PS01-37x120-P150	0150-1204	& PL01-20x500/420	0150-1328
P01-37x120/280x360-C20	-->	PS01-37x120-C20	0150-1237	& PL01-20x500/420	0150-1328

Slider

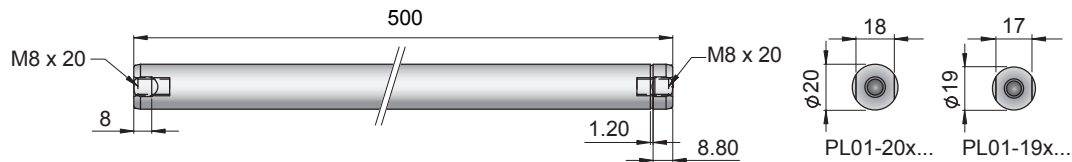

Standard Type	Slider Standard	PL01-20x500/420	0150-1328
Special Sliders	Heavy Duty Slider with WC/C-Coating	PL02-20x500/420	0150-1329
	Hollow Slider hole diameter 6.5mm	PL01-20x500/420-L	0150-1358
	High Clearance Slider d=19mm, m=960g	PL01-19x500/420	0150-1455

Connectors

Motor Connector Wiring

Cable Length:
P01-37x120... 1.5m
P01-37x120...-C20 0.2m

		P01-37...-C P01-37...-C20	P01-37...
Ph 1+	red	A	1
Ph 1-	pink	B	2
Ph 2+	blue	C	3
Ph 2-	grey	D	4
+5VDC	white	E	5
GND	inner Shield	F	6
Sine	yellow	G	7
Cosine	green	H	8
Temp.	black	L	9
Shield	outer Shield	Case	10

Accessoires

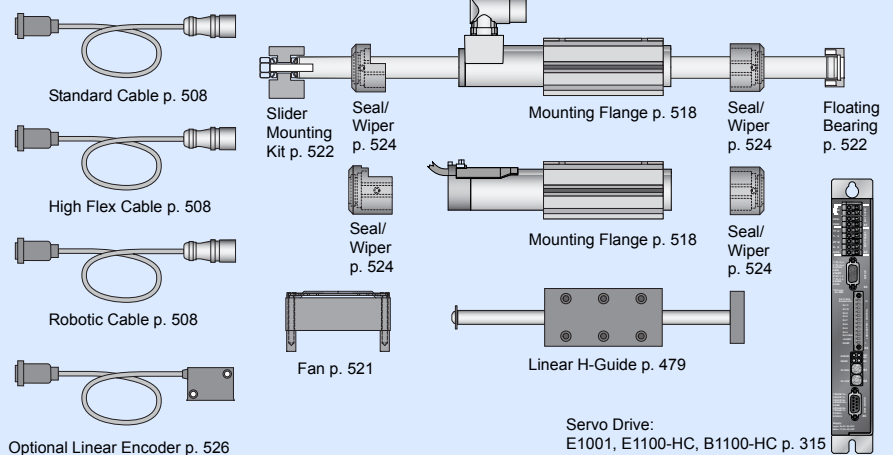

Max. Stroke: 460mm
Peak Force: 163N

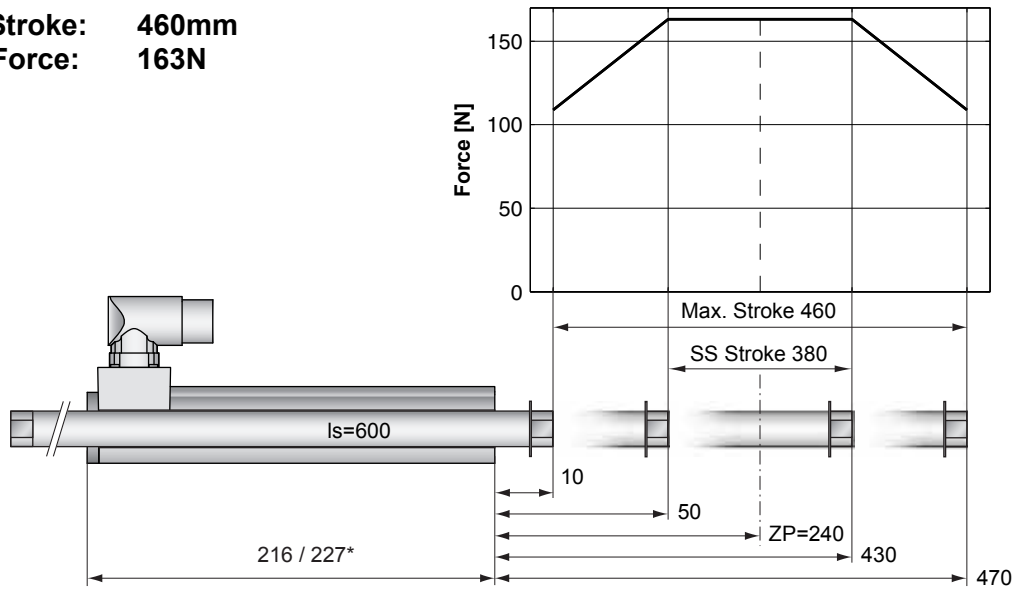

Dimensions in mm
 *Cable Type

Motor Specification

	P01-	Connector Type	Cable Type
		37x120/380x460-C	37x120/380x460-P150 37x120/380x460-C20
Extended Stroke ES	mm (in)	460 (18.11)	460 (18.11)
Standard Stroke SS	mm (in)	380 (14.96)	380 (14.96)
Peak Force E1100-HC	N (lbf)	163 (36.7)	163 (36.7)
Peak Force E1100 / E1001	N (lbf)	163 (36.7)	163 (36.7)
Cont. Force	N (lbf)	29 (6.5)	29 (6.5)
Cont. Force Fan cooling	N (lbf)	54 (12.2)	54 (12.2)
Border Force	%	67	67
Force Constant	N/A (lbf/A)	20.4 (4.59)	20.4 (4.59)
Max. Current @ 72VDC	A	8.0	8.0
Max. Current @ 48VDC	A	6.3	6.3
Max. Velocity @ 72VDC	m/s (in/s)	3.2 (128)	3.2 (128)
Max. Velocity @ 48VDC	m/s (in/s)	2.2 (85)	2.2 (85)
Phase Resist. 25/80 °C	Ohm	6.2/7.5	6.2/7.5
Phase Inductance	mH	3.1	3.1
Thermal Resistance	°K/W	3.6	3.6
Thermal Time Const.	sec	2900	2900
Stator Diameter	mm (in)	37 (1.46)	37 (1.46)
Stator Length	mm (in)	216 (8.50)	227 (8.94)
Stator Mass	g (lb)	740 (1.63)	740 (1.63)
Slider Diameter	mm (in)	20 (0.79)	20 (0.79)
Slider Length	mm (in)	600 (23.62)	600 (23.62)
Slider Mass	g (lb)	1297 (2.86)	1297 (2.86)
Position Repeatability	mm (in)	±0.05 (±0.0020)	±0.05 (±0.0020)
Linearity	%	±0.15	±0.15
Repeatability with EPS	mm (in)	±0.01 (±0.0004)	±0.01 (±0.0004)
Linearity with EPS	mm (in)	±0.01 (±0.0004)	±0.01 (±0.0004)

Position-Time Diagram

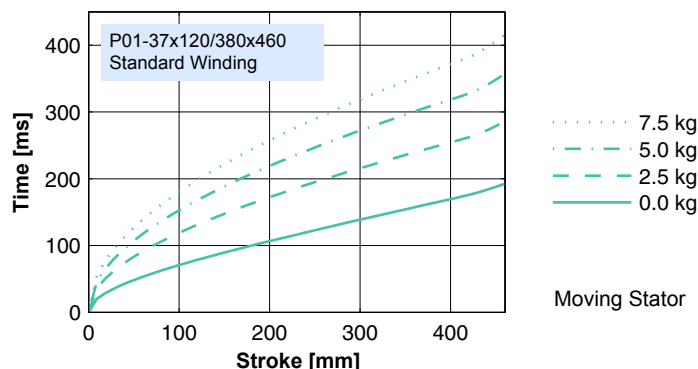

Connector Type

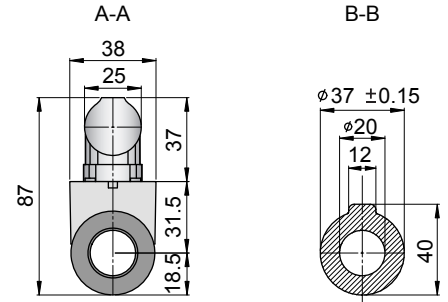
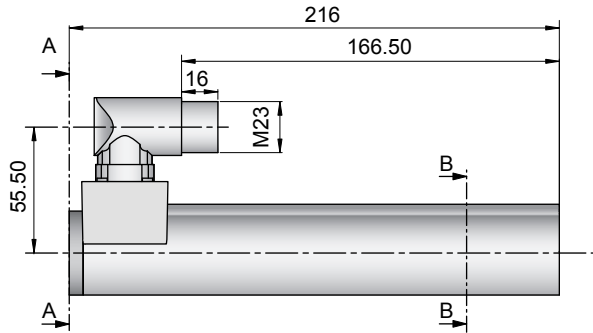

Linear Motor		Stator		Slider	
Type	Art.No	Type	Art. No.	Type	Art. No.
P01-37x120/380x460-C	-->	PS01-37x120-C	0150-1223	& PL01-20x600/520	0150-1330

Cable Type

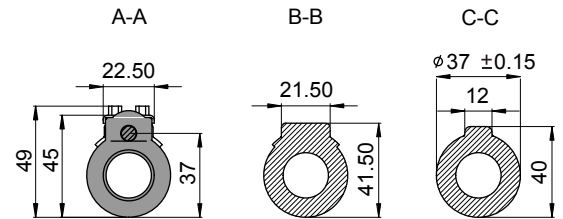
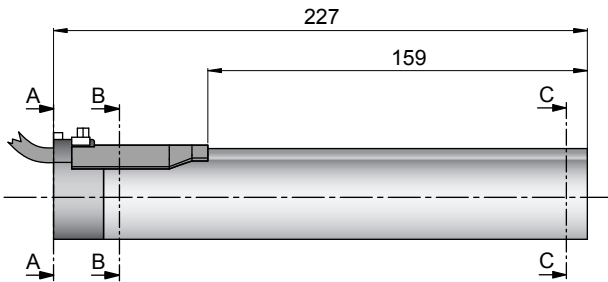

Linear Motor		Stator		Slider	
Type	Art.No	Type	Art. No.	Type	Art. No.
P01-37x120/380x460-P150	-->	PS01-37x120-P150	0150-1204	& PL01-20x600/520	0150-1330
P01-37x120/380x460-C20	-->	PS01-37x120-C20	0150-1237	& PL01-20x600/520	0150-1330

Slider

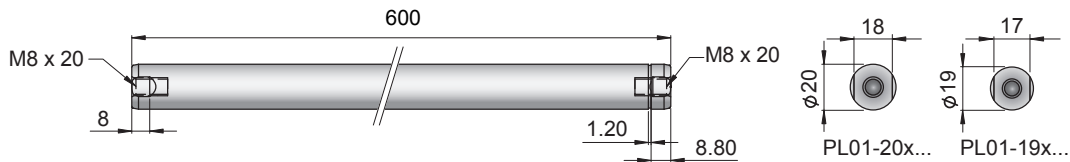

Standard Type	Slider Standard	PL01-20x600/520	0150-1330
Special Sliders	Heavy Duty Slider with WC/C-Coating	PL02-20x600/520	0150-1331
	Hollow Slider hole diameter 6.5mm	PL01-20x600/520-L	0150-1359
	High Clearance Slider d=19mm, m=1171g	PL01-19x600/520	0150-1456

Connectors

Motor Connector Wiring

Cable Length:
P01-37x120... 1.5m
P01-37x120...-C20 0.2m

		P01-37...-C P01-37...-C20	P01-37...
Ph 1+	red	A	1
Ph 1-	pink	B	2
Ph 2+	blue	C	3
Ph 2-	grey	D	4
+5VDC	white	E	5
GND	inner Shield	F	6
Sine	yellow	G	7
Cosine	green	H	8
Temp.	black	L	9
Shield	outer Shield	Case	10

Accessoires

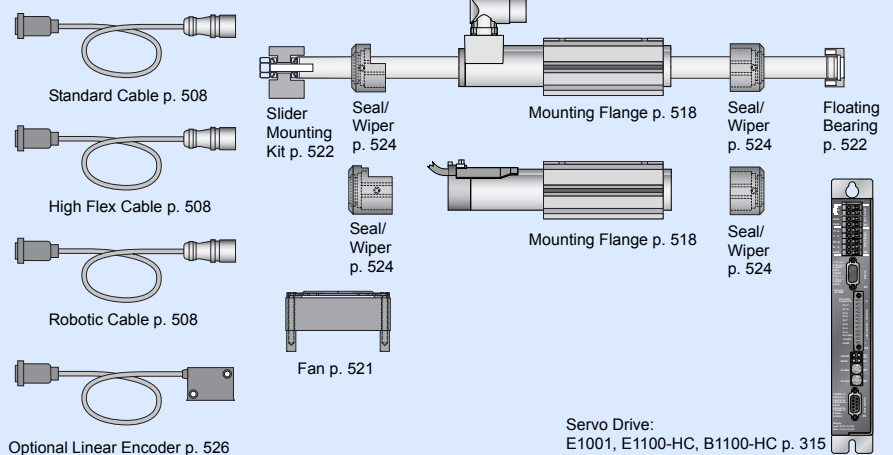

Max. Stroke: 560mm
Peak Force: 163N

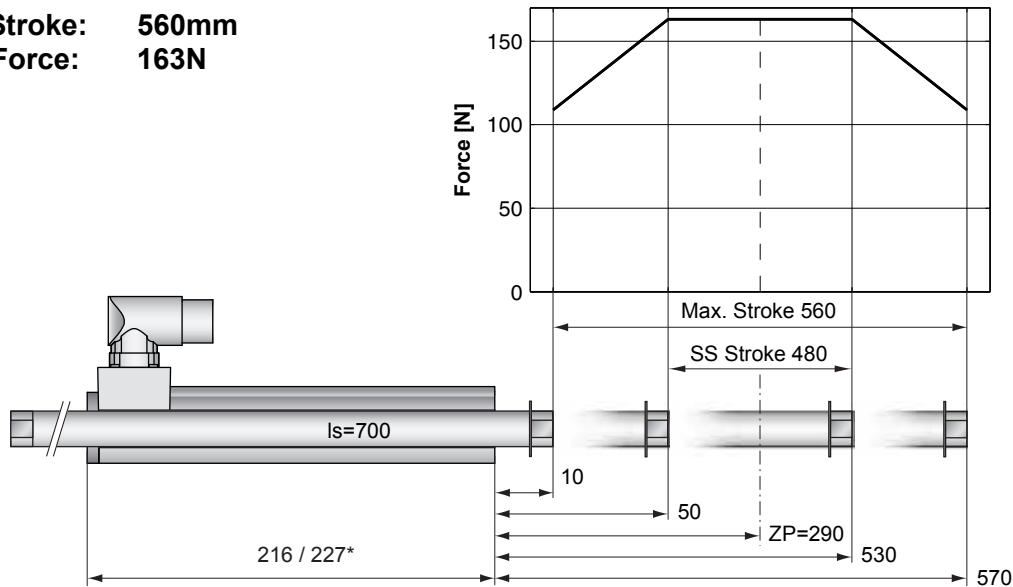

Dimensions in mm
 *Cable Type

Motor Specification

	P01-	Connector Type	Cable Type
		37x120/480x560-C	37x120/480x560-P150 37x120/480x560-C20
Extended Stroke ES	mm (in)	560 (22.05)	560 (22.05)
Standard Stroke SS	mm (in)	480 (18.90)	480 (18.90)
Peak Force E1100-HC	N (lbf)	163 (36.7)	163 (36.7)
Peak Force E1100 / E1001	N (lbf)	163 (36.7)	163 (36.7)
Cont. Force	N (lbf)	29 (6.5)	29 (6.5)
Cont. Force Fan cooling	N (lbf)	54 (12.2)	54 (12.2)
Border Force	%	67	67
Force Constant	N/A (lbf/A)	20.4 (4.59)	20.4 (4.59)
Max. Current @ 72VDC	A	8.0	8.0
Max. Current @ 48VDC	A	6.3	6.3
Max. Velocity @ 72VDC	m/s (in/s)	3.2 (128)	3.2 (128)
Max. Velocity @ 48VDC	m/s (in/s)	2.2 (85)	2.2 (85)
Phase Resist. 25/80 °C	Ohm	6.2/7.5	6.2/7.5
Phase Inductance	mH	3.1	3.1
Thermal Resistance	°K/W	3.6	3.6
Thermal Time Const.	sec	2900	2900
Stator Diameter	mm (in)	37 (1.46)	37 (1.46)
Stator Length	mm (in)	216 (8.50)	227 (8.94)
Stator Mass	g (lb)	740 (1.63)	740 (1.63)
Slider Diameter	mm (in)	20 (0.79)	20 (0.79)
Slider Length	mm (in)	700 (27.56)	700 (27.56)
Slider Mass	g (lb)	1529 (3.37)	1529 (3.37)
Position Repeatability	mm (in)	±0.05 (±0.0020)	±0.05 (±0.0020)
Linearity	%	±0.15	±0.15
Repeatability with EPS	mm (in)	±0.01 (±0.0004)	±0.01 (±0.0004)
Linearity with EPS	mm (in)	±0.01 (±0.0004)	±0.01 (±0.0004)

Position-Time Diagram

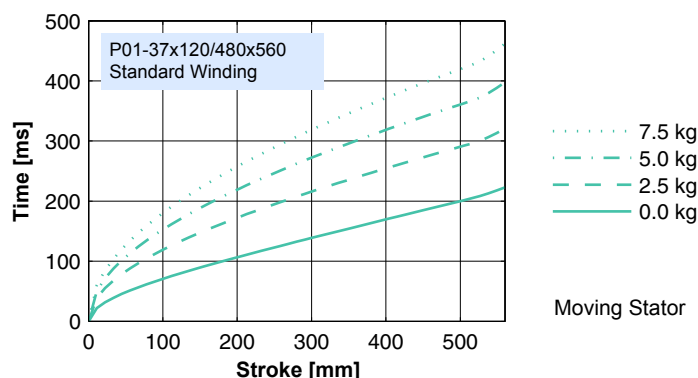

Connector Type

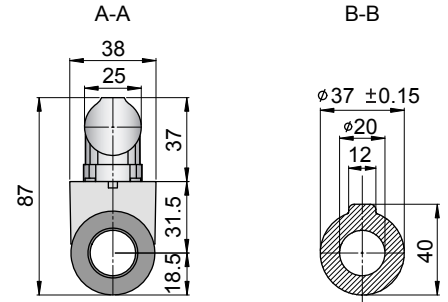
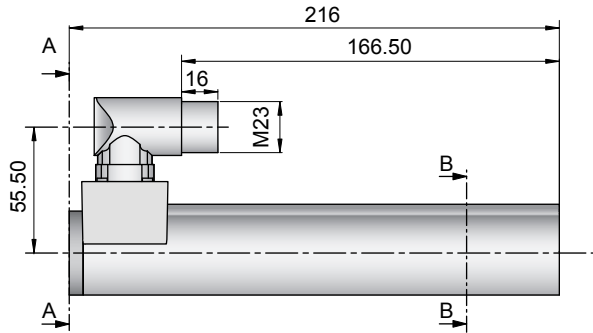

Linear Motor		Stator		Slider	
Type	Art.No	Type	Art. No.	Type	Art. No.
P01-37x120/480x560-C	-->	PS01-37x120-C	0150-1223	& PL01-20x700/620	0150-1332

Cable Type

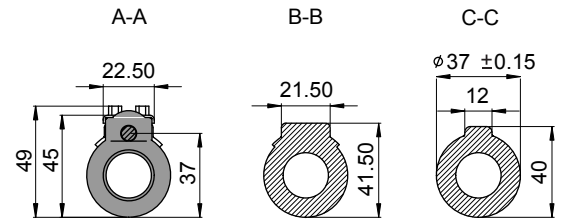
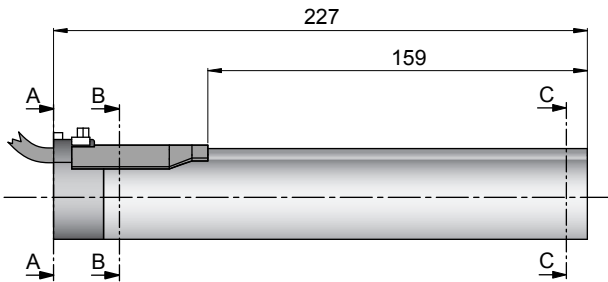

Linear Motor		Stator		Slider	
Type	Art.No	Type	Art. No.	Type	Art. No.
P01-37x120/480x560-P150	-->	PS01-37x120-P150	0150-1204	& PL01-20x700/620	0150-1332
P01-37x120/480x560-C20	-->	PS01-37x120-C20	0150-1237	& PL01-20x700/620	0150-1332

Slider

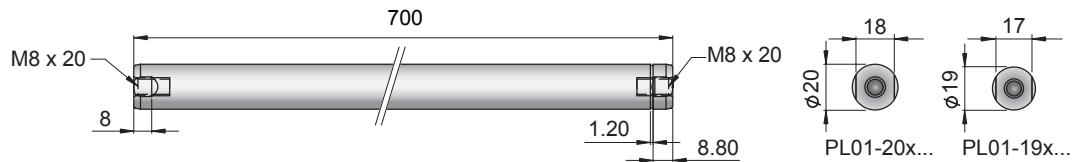

Standard Type	Slider Standard	PL01-20x700/620	0150-1332
Special Sliders	Heavy Duty Slider with WC/C-Coating	PL02-20x700/620	0150-1333
	Hollow Slider hole diameter 6.5mm	PL01-20x700/620-L	0150-1360
	High Clearance Slider d=19mm, m=1380g	PL01-19x700/620	0150-1457

Connectors

Motor Connector Wiring

Cable Length:
P01-37x120... 1.5m
P01-37x120...-C20 0.2m

		P01-37...-C P01-37...-C20	P01-37...
Ph 1+	red	A	1
Ph 1-	pink	B	2
Ph 2+	blue	C	3
Ph 2-	grey	D	4
+5VDC	white	E	5
GND	inner Shield	F	6
Sine	yellow	G	7
Cosine	green	H	8
Temp.	black	L	9
Shield	outer Shield	Case	10

Accessoires

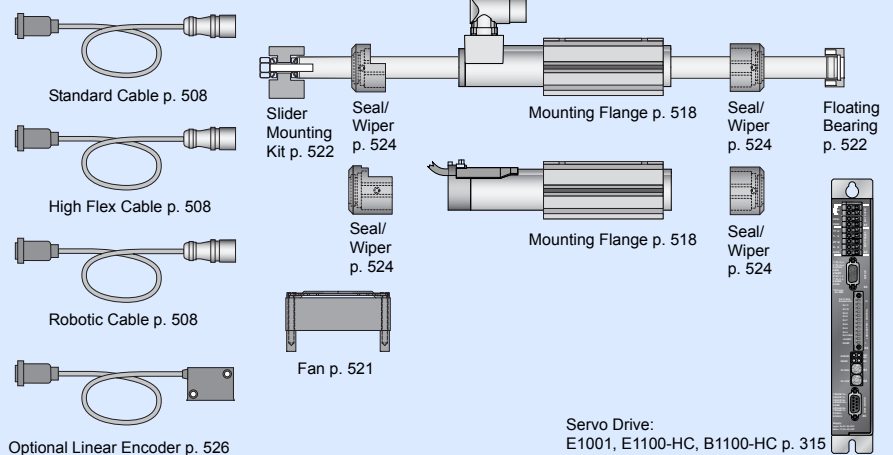

Servo Drive:
E1001, E1100-HC, B1100-HC p. 315

Max. Stroke: 660mm
Peak Force: 163N

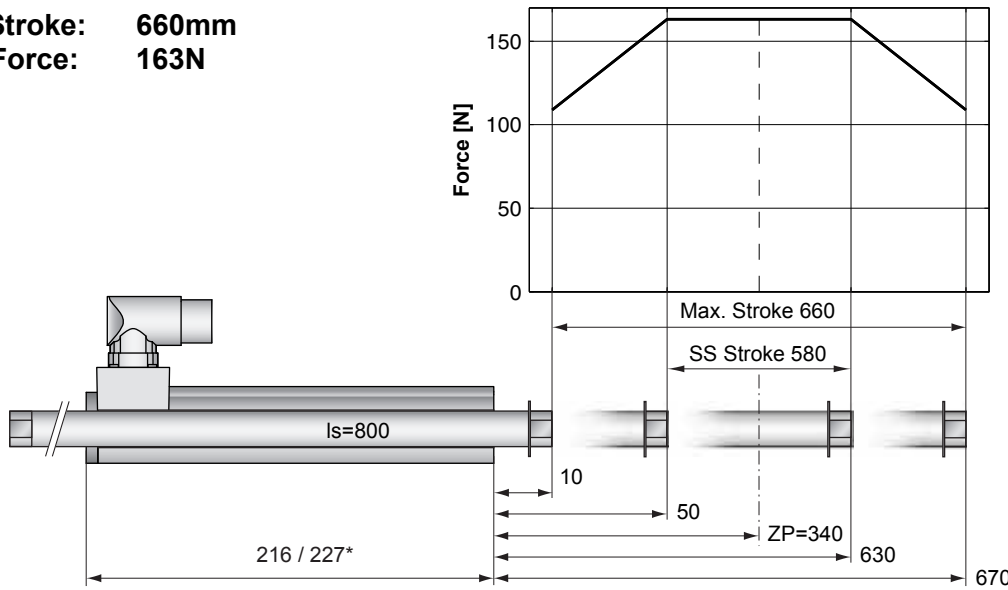

Standard Winding:
 — E1100-HC, 72VDC
 — E1100, 72VDC & E1001, 72VDC

Dimensions in mm
 *Cable Type

Motor Specification

	P01-	Connector Type	Cable Type
		37x120/580x660-C	37x120/580x660-P150 37x120/580x660-C20
Extended Stroke ES	mm (in)	660 (25.98)	660 (25.98)
Standard Stroke SS	mm (in)	580 (22.83)	580 (22.83)
Peak Force E1100-HC	N (lbf)	163 (36.7)	163 (36.7)
Peak Force E1100 / E1001	N (lbf)	163 (36.7)	163 (36.7)
Cont. Force	N (lbf)	29 (6.5)	29 (6.5)
Cont. Force Fan cooling	N (lbf)	54 (12.2)	54 (12.2)
Border Force	%	67	67
Force Constant	N/A (lbf/A)	20.4 (4.59)	20.4 (4.59)
Max. Current @ 72VDC	A	8.0	8.0
Max. Current @ 48VDC	A	6.3	6.3
Max. Velocity @ 72VDC	m/s (in/s)	3.2 (128)	3.2 (128)
Max. Velocity @ 48VDC	m/s (in/s)	2.2 (85)	2.2 (85)
Phase Resist. 25/80 °C	Ohm	6.2/7.5	6.2/7.5
Phase Inductance	mH	3.1	3.1
Thermal Resistance	°K/W	3.6	3.6
Thermal Time Const.	sec	2900	2900
Stator Diameter	mm (in)	37 (1.46)	37 (1.46)
Stator Length	mm (in)	216 (8.50)	227 (8.94)
Stator Mass	g (lb)	740 (1.63)	740 (1.63)
Slider Diameter	mm (in)	20 (0.79)	20 (0.79)
Slider Length	mm (in)	800 (31.50)	800 (31.50)
Slider Mass	g (lb)	1762 (3.88)	1762 (3.88)
Position Repeatability	mm (in)	±0.05 (±0.0020)	±0.05 (±0.0020)
Linearity	%	±0.15	±0.15
Repeatability with EPS	mm (in)	±0.01 (±0.0004)	±0.01 (±0.0004)
Linearity with EPS	mm (in)	±0.01 (±0.0004)	±0.01 (±0.0004)

Position-Time Diagram

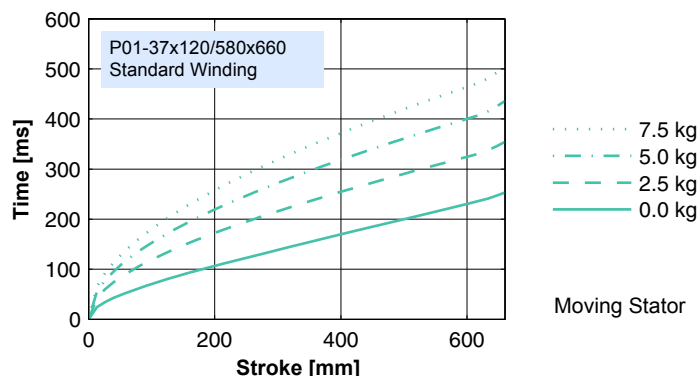

Moving Stator

Connector Type

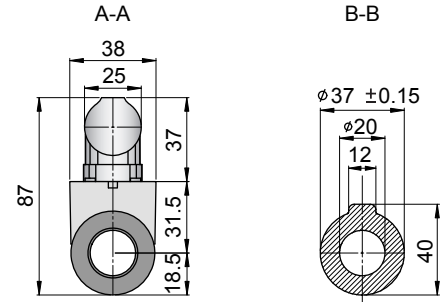
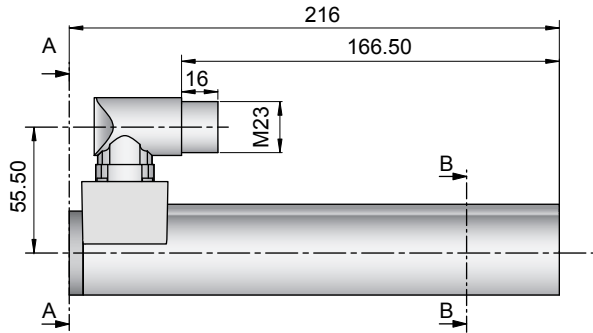

Linear Motor		Stator		Slider	
Type	Art.No	Type	Art. No.	Type	Art. No.
P01-37x120/580x660-C	-->	PS01-37x120-C	0150-1223	& PL01-20x800/720	0150-1334

Cable Type

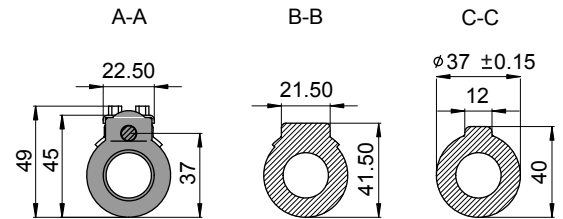
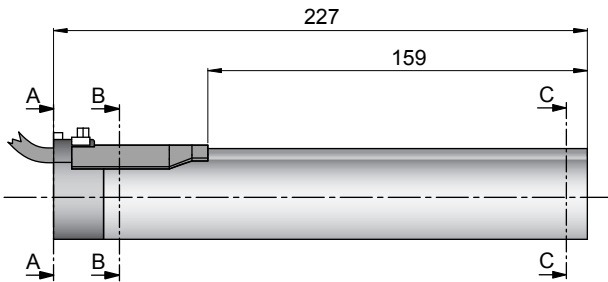

Linear Motor		Stator		Slider	
Type	Art.No	Type	Art. No.	Type	Art. No.
P01-37x120/580x660-P150	-->	PS01-37x120-P150	0150-1204	& PL01-20x800/720	0150-1334
P01-37x120/580x660-C20	-->	PS01-37x120-C20	0150-1237	& PL01-20x800/720	0150-1334

Slider

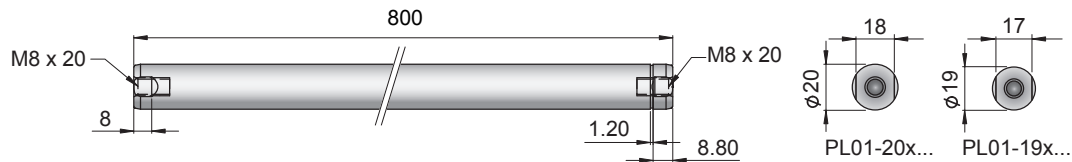

Standard Type	Slider Standard	PL01-20x800/720	0150-1334
Special Sliders	Heavy Duty Slider with WC/C-Coating	PL02-20x800/720	0150-1335
	Hollow Slider hole diameter 6.5mm	PL01-20x800/720-L	0150-1361
	High Clearance Slider d=19mm, m=1590g	PL01-19x800/720	0150-1458

Connectors

Motor Connector Wiring

Cable Length:
P01-37x120... 1.5m
P01-37x120...-C20 0.2m

		P01-37...-C P01-37...-C20	P01-37...
Ph 1+	red	A	1
Ph 1-	pink	B	2
Ph 2+	blue	C	3
Ph 2-	grey	D	4
+5VDC	white	E	5
GND	inner Shield	F	6
Sine	yellow	G	7
Cosine	green	H	8
Temp.	black	L	9
Shield	outer Shield	Case	10

Accessoires

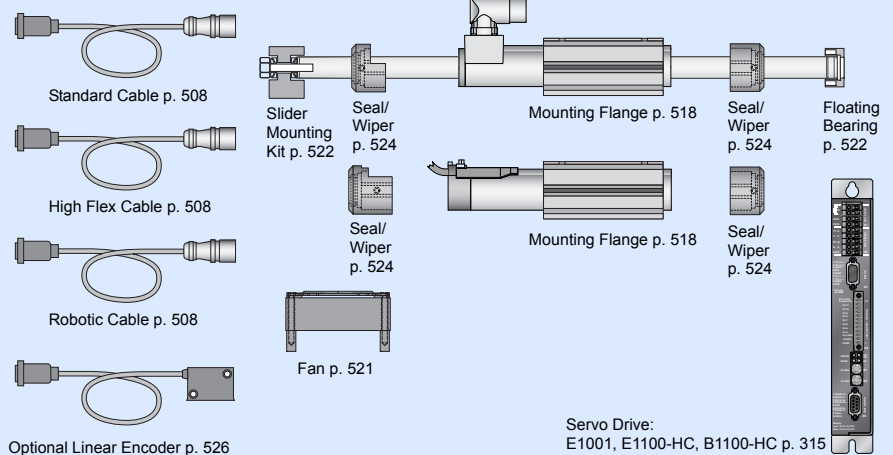

Servo Drive:
E1001, E1100-HC, B1100-HC p. 315

Max. Stroke: 760mm
Peak Force: 163N

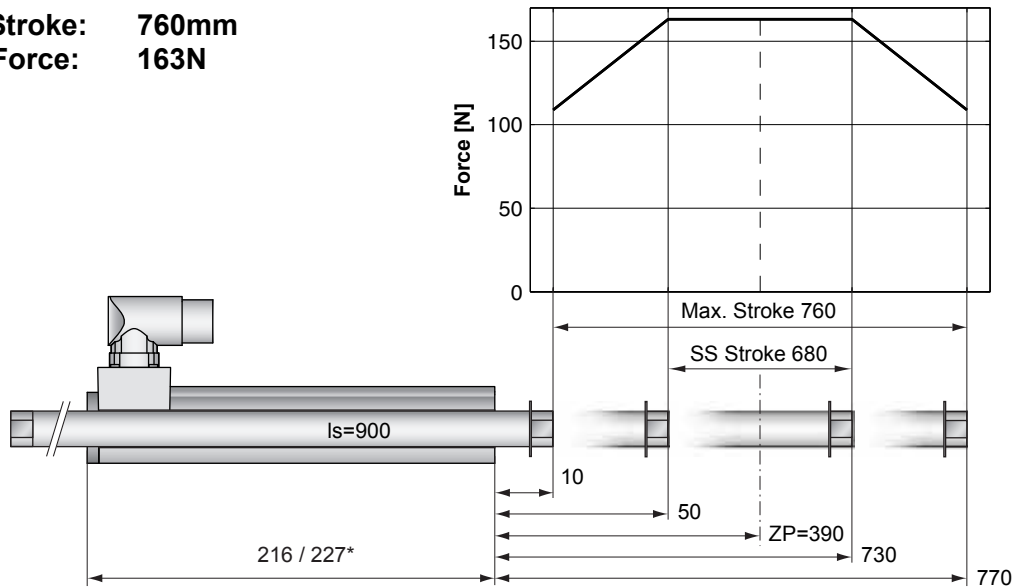

Dimensions in mm
 *Cable Type

Motor Specification

	P01-	Connector Type	Cable Type
		37x120/680x760-C	37x120/680x760-P150 37x120/680x760-C20
Extended Stroke ES	mm (in)	760 (29.92)	760 (29.92)
Standard Stroke SS	mm (in)	680 (26.77)	680 (26.77)
Peak Force E1100-HC	N (lbf)	163 (36.7)	163 (36.7)
Peak Force E1100 / E1001	N (lbf)	163 (36.7)	163 (36.7)
Cont. Force	N (lbf)	29 (6.5)	29 (6.5)
Cont. Force Fan cooling	N (lbf)	54 (12.2)	54 (12.2)
Border Force	%	67	67
Force Constant	N/A (lbf/A)	20.4 (4.59)	20.4 (4.59)
Max. Current @ 72VDC	A	8.0	8.0
Max. Current @ 48VDC	A	6.3	6.3
Max. Velocity @ 72VDC	m/s (in/s)	3.2 (128)	3.2 (128)
Max. Velocity @ 48VDC	m/s (in/s)	2.2 (85)	2.2 (85)
Phase Resist. 25/80 °C	Ohm	6.2/7.5	6.2/7.5
Phase Inductance	mH	3.1	3.1
Thermal Resistance	°K/W	3.6	3.6
Thermal Time Const.	sec	2900	2900
Stator Diameter	mm (in)	37 (1.46)	37 (1.46)
Stator Length	mm (in)	216 (8.50)	227 (8.94)
Stator Mass	g (lb)	740 (1.63)	740 (1.63)
Slider Diameter	mm (in)	20 (0.79)	20 (0.79)
Slider Length	mm (in)	900 (35.43)	900 (35.43)
Slider Mass	g (lb)	1994 (4.40)	1994 (4.40)
Position Repeatability	mm (in)	±0.05 (±0.0020)	±0.05 (±0.0020)
Linearity	%	±0.15	±0.15
Repeatability with EPS	mm (in)	±0.01 (±0.0004)	±0.01 (±0.0004)
Linearity with EPS	mm (in)	±0.01 (±0.0004)	±0.01 (±0.0004)

Position-Time Diagram

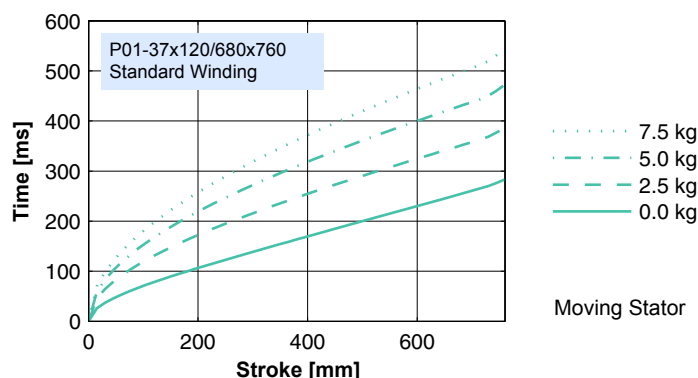

Connector Type

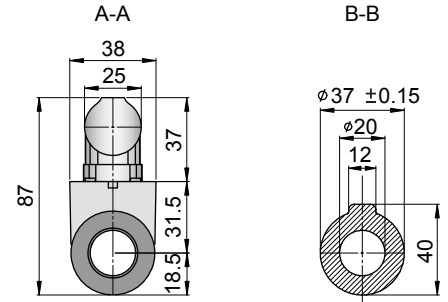
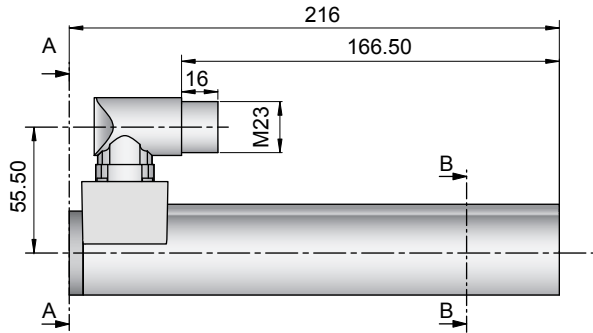

Linear Motor		Stator		Slider	
Type	Art.No	Type	Art. No.	Type	Art. No.
P01-37x120/680x760-C	-->	PS01-37x120-C	0150-1223	& PL01-20x900/820	0150-1336

Cable Type

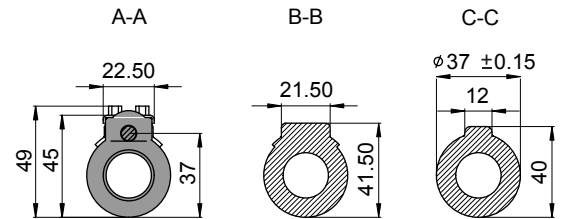
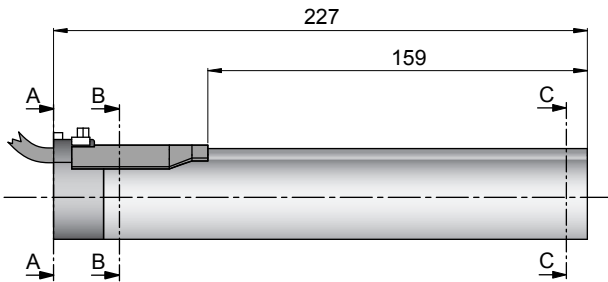

Linear Motor		Stator		Slider	
Type	Art.No	Type	Art. No.	Type	Art. No.
P01-37x120/680x760-P150	-->	PS01-37x120-P150	0150-1204	& PL01-20x900/820	0150-1336
P01-37x120/680x760-C20	-->	PS01-37x120-C20	0150-1237	& PL01-20x900/820	0150-1336

Slider

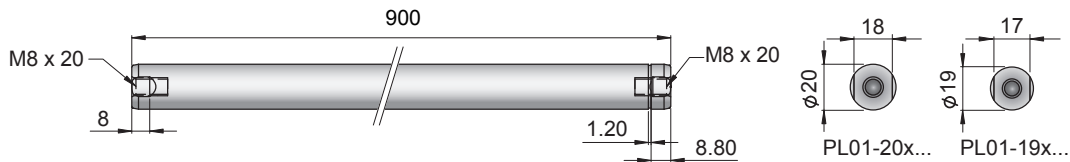

Standard Type	Slider Standard	PL01-20x900/820	0150-1336
Special Sliders	Heavy Duty Slider with WC/C-Coating	PL02-20x900/820	0150-1337
	Hollow Slider hole diameter 6.5mm	PL01-20x900/820-L	0150-1362
	High Clearance Slider d=19mm	PL01-19x900/820	on request

Connectors

Motor Connector Wiring

Cable Length:
P01-37x120... 1.5m
P01-37x120...-C20 0.2m

		P01-37...-C P01-37...-C20	P01-37...
Ph 1+	red	A	1
Ph 1-	pink	B	2
Ph 2+	blue	C	3
Ph 2-	grey	D	4
+5VDC	white	E	5
GND	inner Shield	F	6
Sine	yellow	G	7
Cosine	green	H	8
Temp.	black	L	9
Shield	outer Shield	Case	10

Accessoires

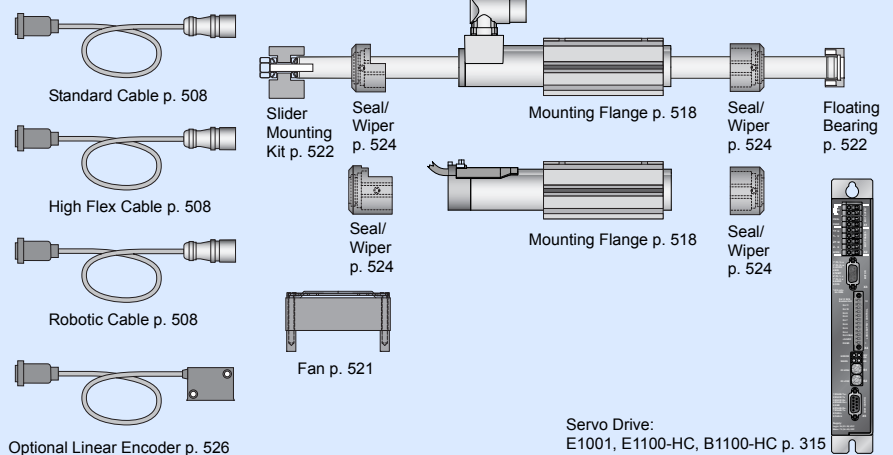

Max. Stroke: 860mm
Peak Force: 163N

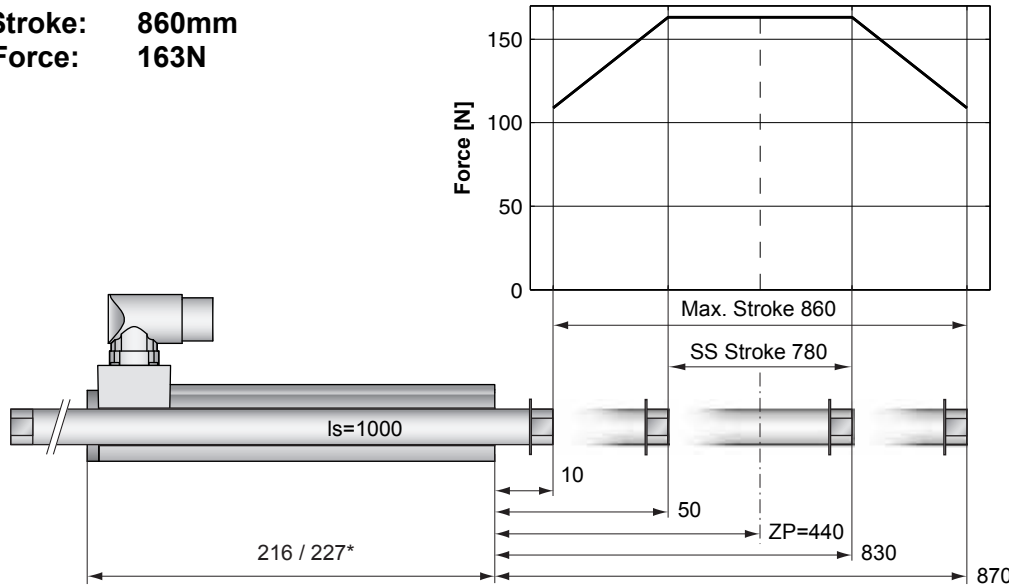

Standard Winding:
 — E1100-HC, 72VDC
 — E1100, 72VDC & E1001, 72VDC

Dimensions in mm
 *Cable Type

Motor Specification

	P01-	Connector Type	Cable Type
		37x120/780x860-C	37x120/780x860-P150 37x120/780x860-C20
Extended Stroke ES	mm (in)	860 (33.86)	860 (33.86)
Standard Stroke SS	mm (in)	780 (30.71)	780 (30.71)
Peak Force E1100-HC	N (lbf)	163 (36.7)	163 (36.7)
Peak Force E1100 / E1001	N (lbf)	163 (36.7)	163 (36.7)
Cont. Force	N (lbf)	29 (6.5)	29 (6.5)
Cont. Force Fan cooling	N (lbf)	54 (12.2)	54 (12.2)
Border Force	%	67	67
Force Constant	N/A (lbf/A)	20.4 (4.59)	20.4 (4.59)
Max. Current @ 72VDC	A	8.0	8.0
Max. Current @ 48VDC	A	6.3	6.3
Max. Velocity @ 72VDC	m/s (in/s)	3.2 (128)	3.2 (128)
Max. Velocity @ 48VDC	m/s (in/s)	2.2 (85)	2.2 (85)
Phase Resist. 25/80 °C	Ohm	6.2/7.5	6.2/7.5
Phase Inductance	mH	3.1	3.1
Thermal Resistance	°K/W	3.6	3.6
Thermal Time Const.	sec	2900	2900
Stator Diameter	mm (in)	37 (1.46)	37 (1.46)
Stator Length	mm (in)	216 (8.50)	227 (8.94)
Stator Mass	g (lb)	740 (1.63)	740 (1.63)
Slider Diameter	mm (in)	20 (0.79)	20 (0.79)
Slider Length	mm (in)	1000 (39.37)	1000 (39.37)
Slider Mass	g (lb)	2227 (4.91)	2227 (4.91)
Position Repeatability	mm (in)	±0.05 (±0.0020)	±0.05 (±0.0020)
Linearity	%	±0.15	±0.15
Repeatability with EPS	mm (in)	±0.01 (±0.0004)	±0.01 (±0.0004)
Linearity with EPS	mm (in)	±0.01 (±0.0004)	±0.01 (±0.0004)

Position-Time Diagram

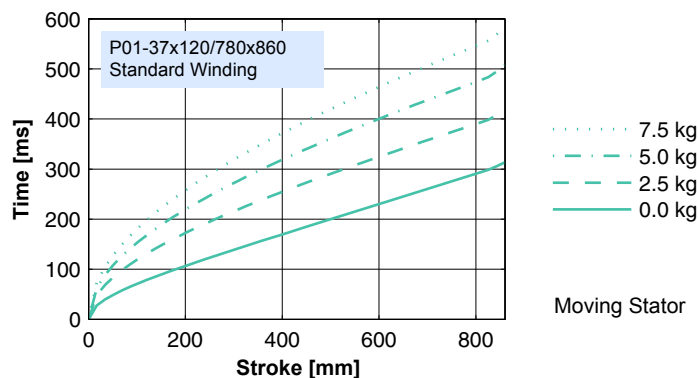

Connector Type

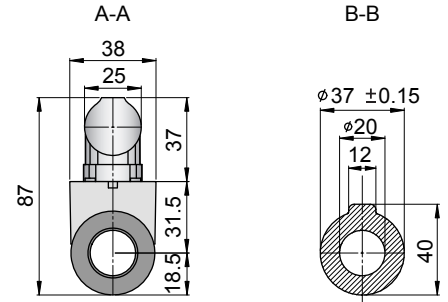
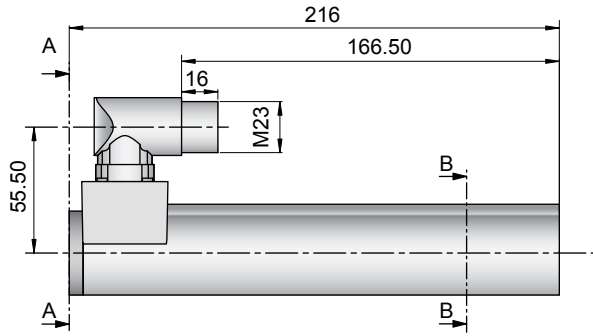

Linear Motor		Stator		Slider	
Type	Art.No	Type	Art. No.	Type	Art. No.
P01-37x120/780x860-C	-->	PS01-37x120-C	0150-1223	& PL01-20x1000/920	0150-1338

Cable Type

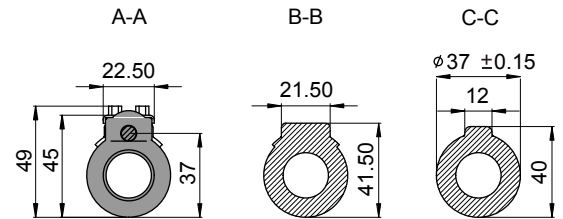
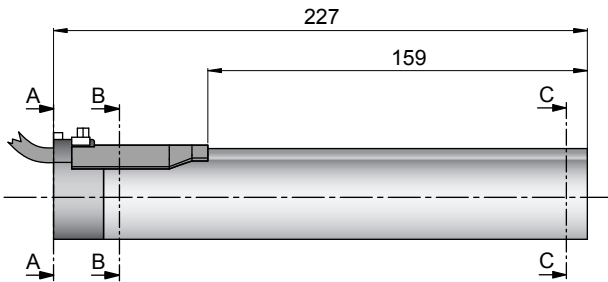

Linear Motor		Stator		Slider	
Type	Art.No	Type	Art. No.	Type	Art. No.
P01-37x120/780x860-P150	-->	PS01-37x120-P150	0150-1204	& PL01-20x1000/920	0150-1338
P01-37x120/780x860-C20	-->	PS01-37x120-C20	0150-1237	& PL01-20x1000/920	0150-1338

Slider

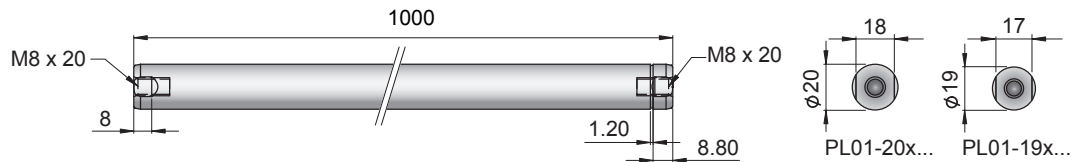

Standard Type	Slider Standard	PL01-20x1000/920	0150-1338
Special Sliders	Heavy Duty Slider with WC/C-Coating	PL02-20x1000/920	on request
	Hollow Slider hole diameter 6.5mm	PL01-20x1000/920-L	0150-1364
	High Clearance Slider d=19mm	PL01-19x1000/920	on request

Connectors

Motor Connector Wiring

Cable Length:
P01-37x120... 1.5m
P01-37x120...-C20 0.2m

		P01-37...-C P01-37...-C20	P01-37...
Ph 1+	red	A	1
Ph 1-	pink	B	2
Ph 2+	blue	C	3
Ph 2-	grey	D	4
+5VDC	white	E	5
GND	inner Shield	F	6
Sine	yellow	G	7
Cosine	green	H	8
Temp.	black	L	9
Shield	outer Shield	Case	10

Accessoires

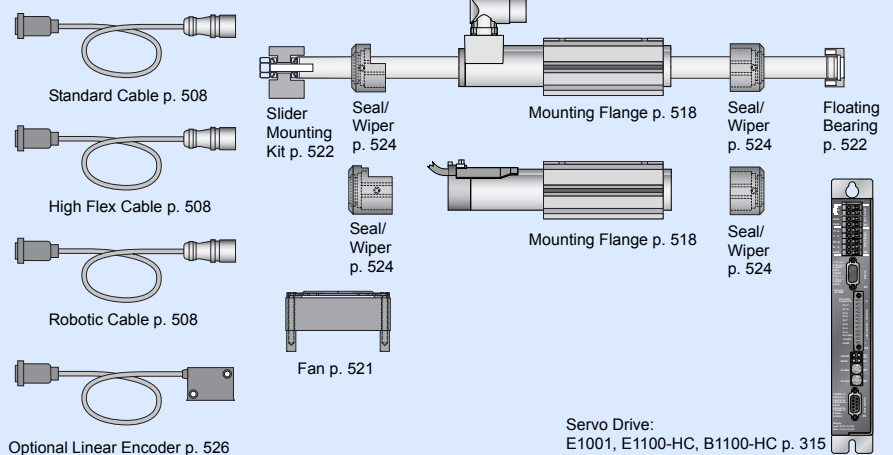

Servo Drive:
E1001, E1100-HC, B1100-HC p. 315

Max. Stroke: 1060mm
Peak Force: 163N

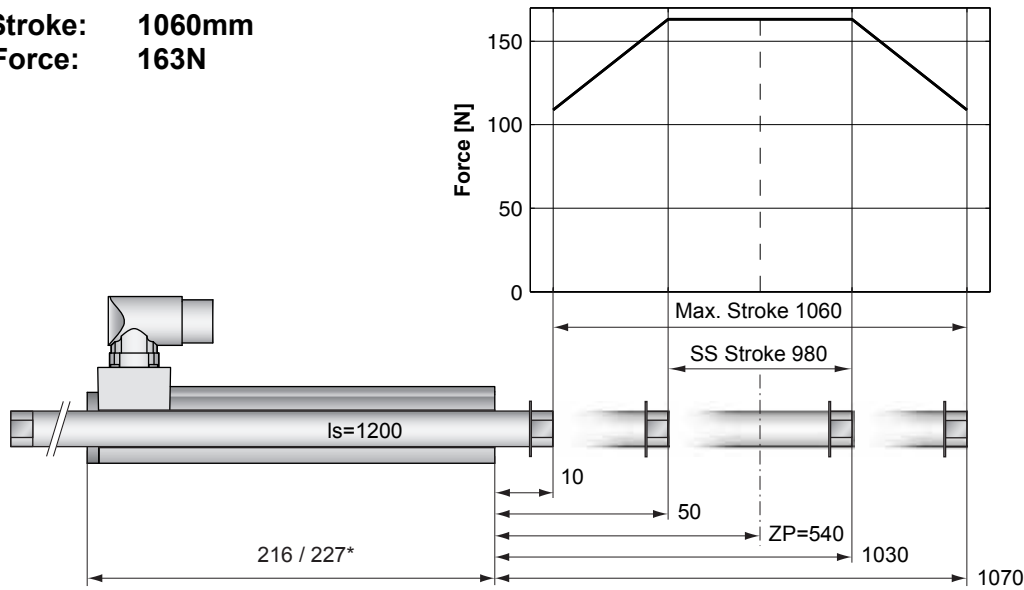

Standard Winding:
 — E1100-HC, 72VDC
 — E1100, 72VDC & E1001, 72VDC

Dimensions in mm
 *Cable Type

Motor Specification

	P01-	Connector Type	Cable Type
		37x120/980x1060-C	37x120/980x1060-P150 37x120/980x1060-C20
Extended Stroke ES	mm (in)	1060 (41.73)	1060 (41.73)
Standard Stroke SS	mm (in)	980 (38.58)	980 (38.58)
Peak Force E1100-HC	N (lbf)	163 (36.7)	163 (36.7)
Peak Force E1100 / E1001	N (lbf)	163 (36.7)	163 (36.7)
Cont. Force	N (lbf)	29 (6.5)	29 (6.5)
Cont. Force Fan cooling	N (lbf)	54 (12.2)	54 (12.2)
Border Force	%	67	67
Force Constant	N/A (lbf/A)	20.4 (4.59)	20.4 (4.59)
Max. Current @ 72VDC	A	8.0	8.0
Max. Current @ 48VDC	A	6.3	6.3
Max. Velocity @ 72VDC	m/s (in/s)	3.2 (128)	3.2 (128)
Max. Velocity @ 48VDC	m/s (in/s)	2.2 (85)	2.2 (85)
Phase Resist. 25/80 °C	Ohm	6.2/7.5	6.2/7.5
Phase Inductance	mH	3.1	3.1
Thermal Resistance	°K/W	3.6	3.6
Thermal Time Const.	sec	2900	2900
Stator Diameter	mm (in)	37 (1.46)	37 (1.46)
Stator Length	mm (in)	216 (8.50)	227 (8.94)
Stator Mass	g (lb)	740 (1.63)	740 (1.63)
Slider Diameter	mm (in)	20 (0.79)	20 (0.79)
Slider Length	mm (in)	1200 (47.24)	1200 (47.24)
Slider Mass	g (lb)	2692 (5.93)	2692 (5.93)
Position Repeatability	mm (in)	±0.05 (±0.0020)	±0.05 (±0.0020)
Linearity	%	±0.10	±0.10
Repeatability with EPS	mm (in)	±0.01 (±0.0004)	±0.01 (±0.0004)
Linearity with EPS	mm (in)	±0.01 (±0.0004)	±0.01 (±0.0004)

Position-Time Diagram

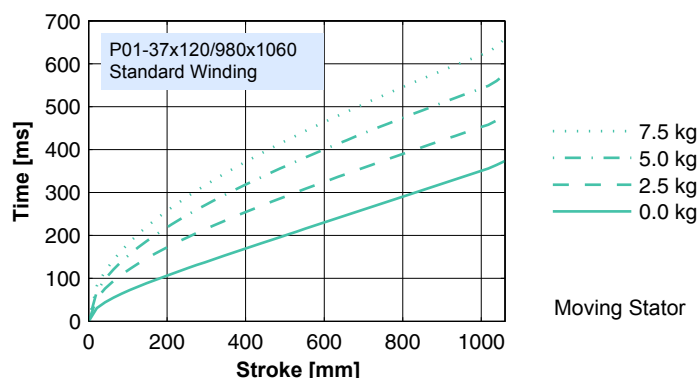

Connector Type

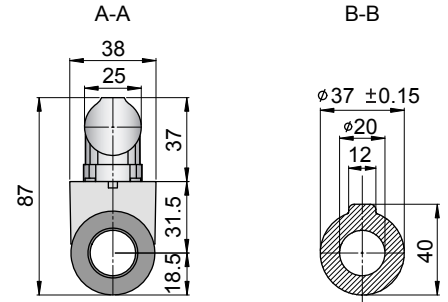
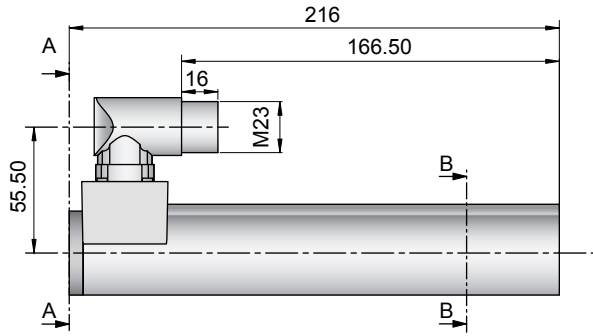

Linear Motor		Stator		Slider	
Type	Art.No	Type	Art. No.	Type	Art. No.
P01-37x120/980x1060-C	-->	PS01-37x120-C	0150-1223	& PL01-20x1200/1120	0150-1340

Cable Type

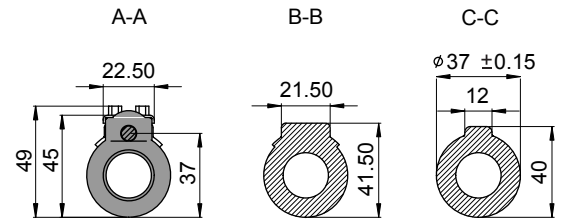
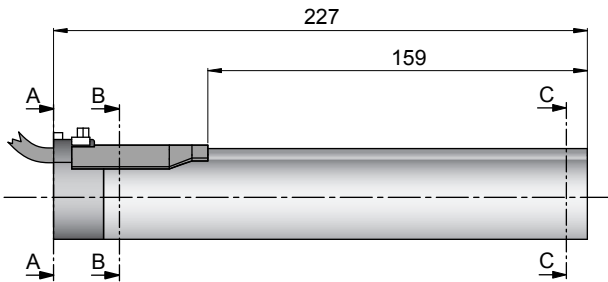

Linear Motor		Stator		Slider	
Type	Art.No	Type	Art. No.	Type	Art. No.
P01-37x120/980x1060-P150	-->	PS01-37x120-P150	0150-1204	& PL01-20x1200/1120	0150-1340
P01-37x120/980x1060-C20	-->	PS01-37x120-C20	0150-1237	& PL01-20x1200/1120	0150-1340

Slider

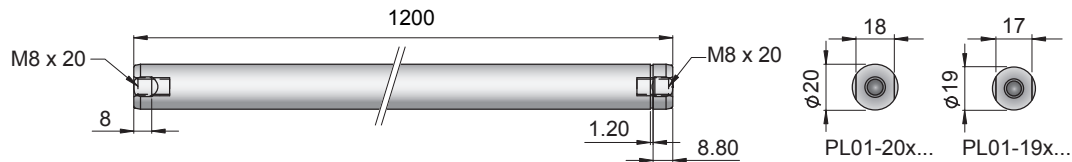

Standard Type	Slider Standard	PL01-20x1200/1120	0150-1340
Special Sliders	Heavy Duty Slider with WC/C-Coating	PL02-20x1200/1120	on request
	Hollow Slider hole diameter 6.5mm	PL01-20x1200/1120-L	0150-1376
	High Clearance Slider d=19mm	PL01-19x1200/1120	on request

Connectors

Motor Connector Wiring

Cable Length:
P01-37x120... 1.5m
P01-37x120...-C20 0.2m

		P01-37...-C P01-37...-C20	P01-37...
Ph 1+	red	A	1
Ph 1-	pink	B	2
Ph 2+	blue	C	3
Ph 2-	grey	D	4
+5VDC	white	E	5
GND	inner Shield	F	6
Sine	yellow	G	7
Cosine	green	H	8
Temp.	black	L	9
Shield	outer Shield	Case	10

Accessoires

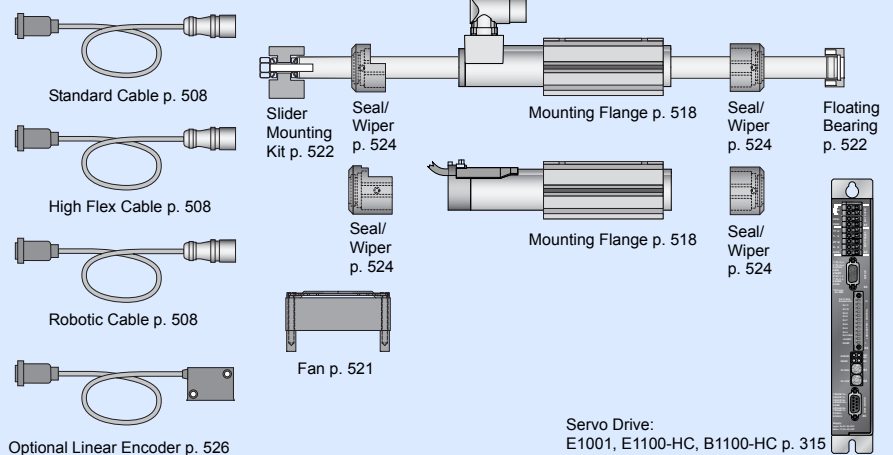

Servo Drive:
E1001, E1100-HC, B1100-HC p. 315

Max. Stroke: 1260mm
Peak Force: 163N

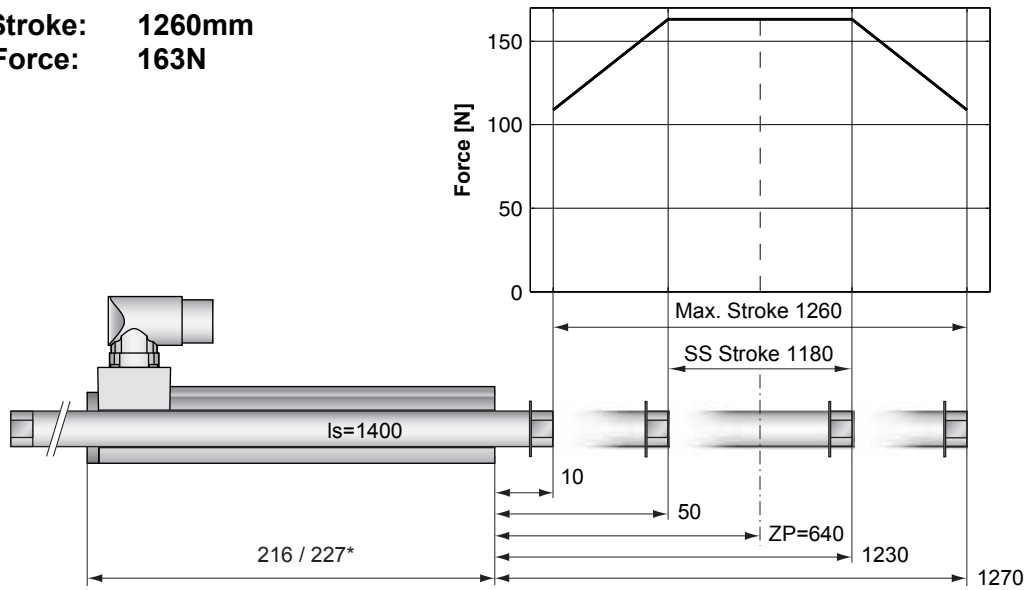

Dimensions in mm
 *Cable Type

Motor Specification

	P01-	Connector Type	Cable Type
		37x120/1180x1260-C	37x120/1180x1260-P150 37x120/1180x1260-C20
Extended Stroke ES	mm (in)	1260 (49.61)	1260 (49.61)
Standard Stroke SS	mm (in)	1180 (46.46)	1180 (46.46)
Peak Force E1100-HC	N (lbf)	163 (36.7)	163 (36.7)
Peak Force E1100 / E1001	N (lbf)	163 (36.7)	163 (36.7)
Cont. Force	N (lbf)	29 (6.5)	29 (6.5)
Cont. Force Fan cooling	N (lbf)	54 (12.2)	54 (12.2)
Border Force	%	67	67
Force Constant	N/A (lbf/A)	20.4 (4.59)	20.4 (4.59)
Max. Current @ 72VDC	A	8.0	8.0
Max. Current @ 48VDC	A	6.3	6.3
Max. Velocity @ 72VDC	m/s (in/s)	3.2 (128)	3.2 (128)
Max. Velocity @ 48VDC	m/s (in/s)	2.2 (85)	2.2 (85)
Phase Resist. 25/80 °C	Ohm	6.2/7.5	6.2/7.5
Phase Inductance	mH	3.1	3.1
Thermal Resistance	°K/W	3.6	3.6
Thermal Time Const.	sec	2900	2900
Stator Diameter	mm (in)	37 (1.46)	37 (1.46)
Stator Length	mm (in)	216 (8.50)	227 (8.94)
Stator Mass	g (lb)	740 (1.63)	740 (1.63)
Slider Diameter	mm (in)	20 (0.79)	20 (0.79)
Slider Length	mm (in)	1400 (55.12)	1400 (55.12)
Slider Mass	g (lb)	3157 (6.96)	3157 (6.96)
Position Repeatability	mm (in)	±0.05 (±0.0020)	±0.05 (±0.0020)
Linearity	%	±0.10	±0.10
Repeatability with EPS	mm (in)	±0.01 (±0.0004)	±0.01 (±0.0004)
Linearity with EPS	mm (in)	±0.01 (±0.0004)	±0.01 (±0.0004)

Position-Time Diagram

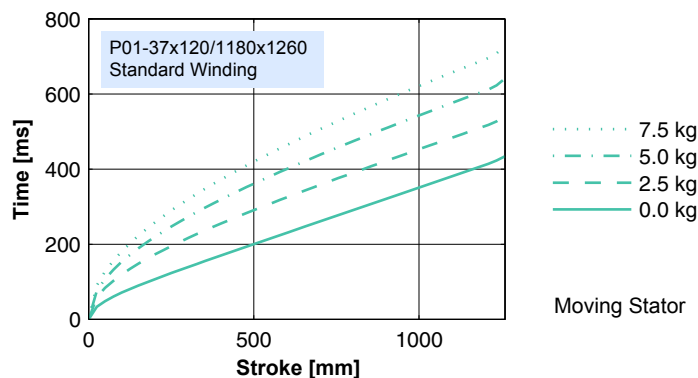

Connector Type

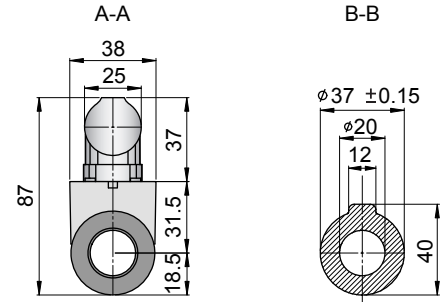
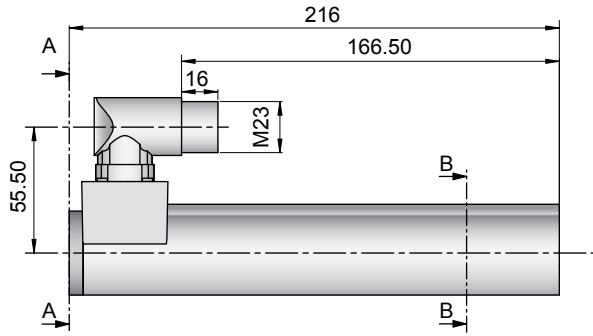

Linear Motor		Stator		Slider	
Type	Art.No	Type	Art. No.	Type	Art. No.
P01-37x120/1180x1260-C	-->	PS01-37x120-C	0150-1223	& PL01-20x1400/1320	0150-1342

Cable Type

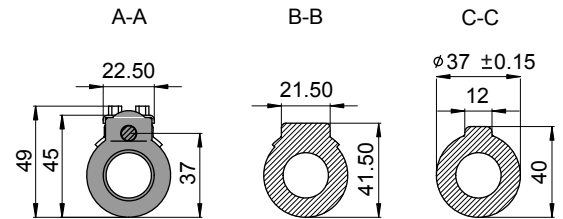
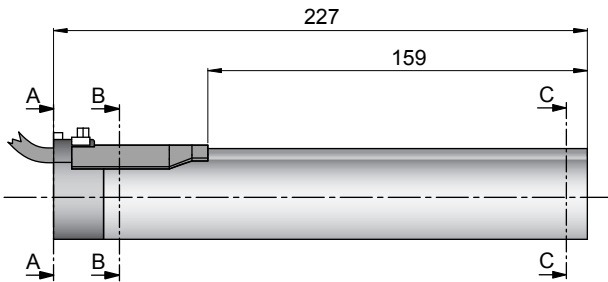

Linear Motor		Stator		Slider	
Type	Art.No	Type	Art. No.	Type	Art. No.
P01-37x120/1180x1260-P150	-->	PS01-37x120-P150	0150-1204	& PL01-20x1400/1320	0150-1342
P01-37x120/1180x1260-C20	-->	PS01-37x120-C20	0150-1237	& PL01-20x1400/1320	0150-1342

Slider

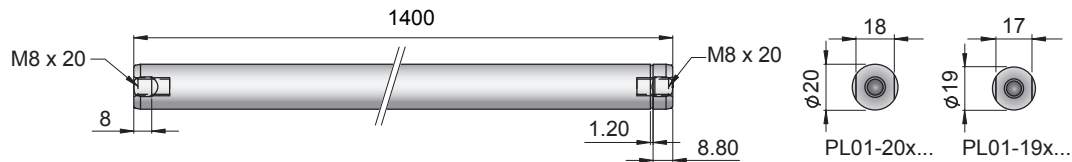

Standard Type	Slider Standard	PL01-20x1400/1320	0150-1342
Special Sliders	Heavy Duty Slider with WC/C-Coating	PL02-20x1400/1320	on request
	Hollow Slider hole diameter 6.5mm	PL01-20x1400/1320-L	on request
	High Clearance Slider d=19mm	PL01-19x1400/1320	on request

Connectors

Motor Connector Wiring

Cable Length:
P01-37x120... 1.5m
P01-37x120...-C20 0.2m

		P01-37...-C P01-37...-C20	P01-37...
Ph 1+	red	A	1
Ph 1-	pink	B	2
Ph 2+	blue	C	3
Ph 2-	grey	D	4
+5VDC	white	E	5
GND	inner Shield	F	6
Sine	yellow	G	7
Cosine	green	H	8
Temp.	black	L	9
Shield	outer Shield	Case	10

Accessoires

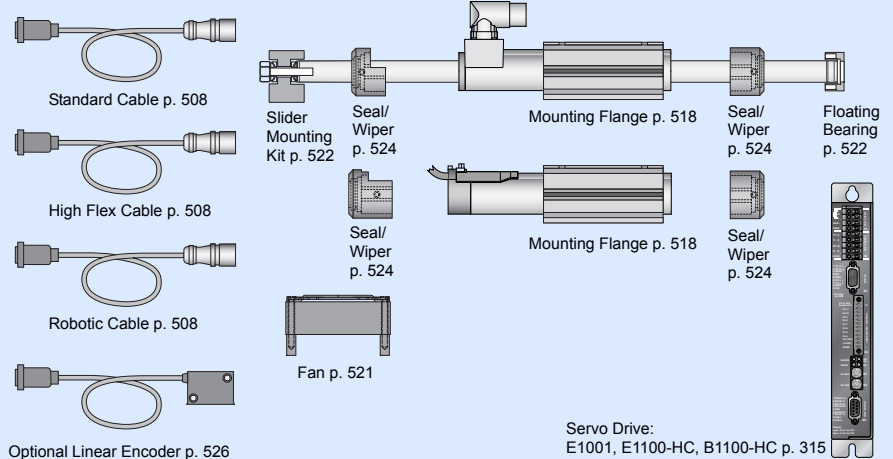

Servo Drive:
E1001, E1100-HC, B1100-HC p. 315

Max. Stroke: 1460mm
Peak Force: 163N

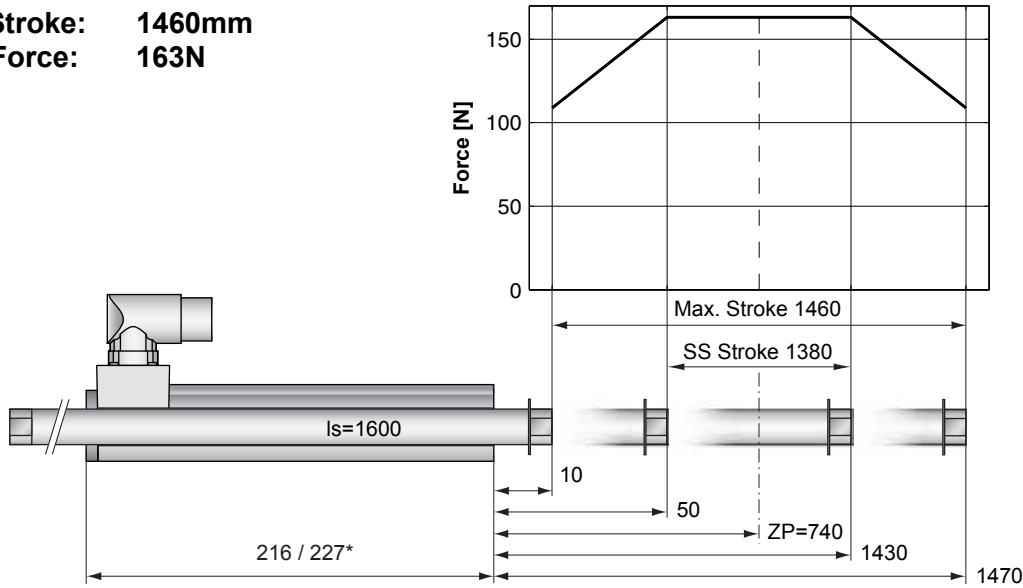

Dimensions in mm
 *Cable Type

Motor Specification

	P01-	Connector Type	Cable Type
		37x120/1380x1460-C	37x120/1380x1460-P150 37x120/1380x1460-C20
Extended Stroke ES	mm (in)	1460 (57.48)	1460 (57.48)
Standard Stroke SS	mm (in)	1380 (54.33)	1380 (54.33)
Peak Force E1100-HC	N (lbf)	163 (36.7)	163 (36.7)
Peak Force E1100 / E1001	N (lbf)	163 (36.7)	163 (36.7)
Cont. Force	N (lbf)	29 (6.5)	29 (6.5)
Cont. Force Fan cooling	N (lbf)	54 (12.2)	54 (12.2)
Border Force	%	67	67
Force Constant	N/A (lbf/A)	20.4 (4.59)	20.4 (4.59)
Max. Current @ 72VDC	A	8.0	8.0
Max. Current @ 48VDC	A	6.3	6.3
Max. Velocity @ 72VDC	m/s (in/s)	3.2 (128)	3.2 (128)
Max. Velocity @ 48VDC	m/s (in/s)	2.2 (85)	2.2 (85)
Phase Resist. 25/80 °C	Ohm	6.2/7.5	6.2/7.5
Phase Inductance	mH	3.1	3.1
Thermal Resistance	°K/W	3.6	3.6
Thermal Time Const.	sec	2900	2900
Stator Diameter	mm (in)	37 (1.46)	37 (1.46)
Stator Length	mm (in)	216 (8.50)	227 (8.94)
Stator Mass	g (lb)	740 (1.63)	740 (1.63)
Slider Diameter	mm (in)	20 (0.79)	20 (0.79)
Slider Length	mm (in)	1600 (62.99)	1600 (62.99)
Slider Mass	g (lb)	3622 (7.99)	3622 (7.99)
Position Repeatability	mm (in)	±0.05 (±0.0020)	±0.05 (±0.0020)
Linearity	%	±0.10	±0.10
Repeatability with EPS	mm (in)	±0.01 (±0.0004)	±0.01 (±0.0004)
Linearity with EPS	mm (in)	±0.01 (±0.0004)	±0.01 (±0.0004)

Position-Time Diagram

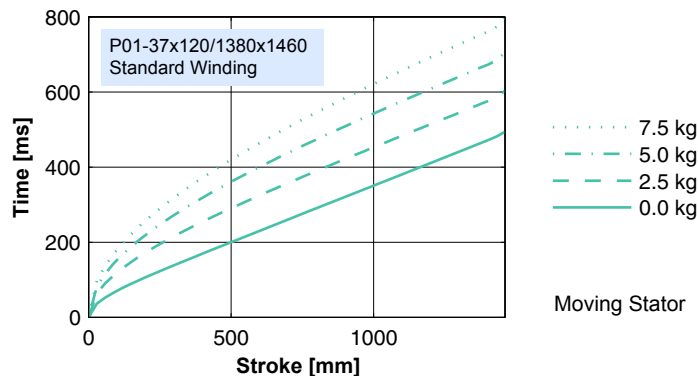

Connector Type

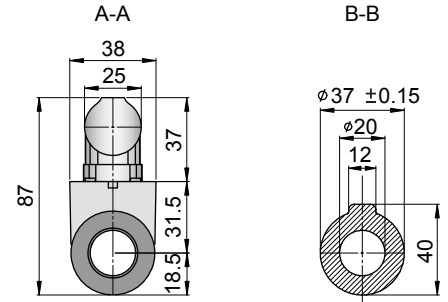
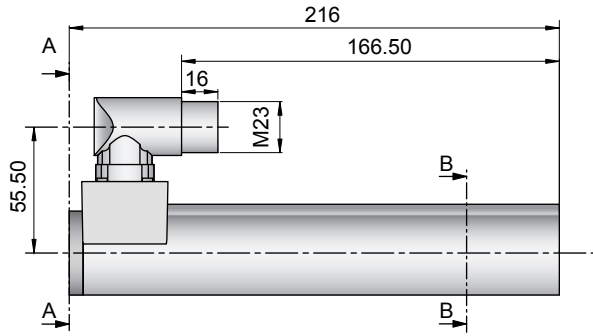

Linear Motor		Stator		Slider	
Type	Art.No	Type	Art. No.	Type	Art. No.
P01-37x120/1380x1460-C	-->	PS01-37x120-C	0150-1223	& PL01-20x1600/1520	0150-1344

Cable Type

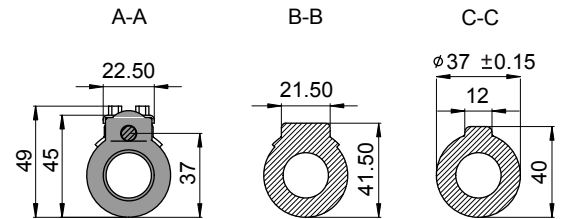
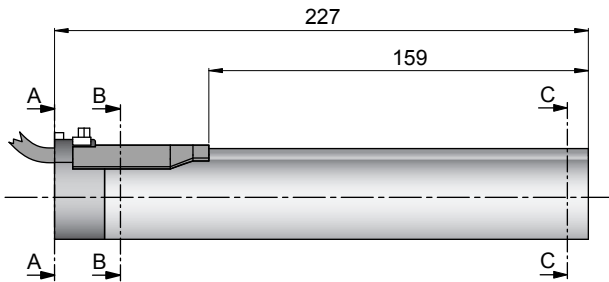

Linear Motor		Stator		Slider	
Type	Art.No	Type	Art. No.	Type	Art. No.
P01-37x120/1380x1460-P150	-->	PS01-37x120-P150	0150-1204	& PL01-20x1600/1520	0150-1344
P01-37x120/1380x1460-C20	-->	PS01-37x120-C20	0150-1237	& PL01-20x1600/1520	0150-1344

Slider

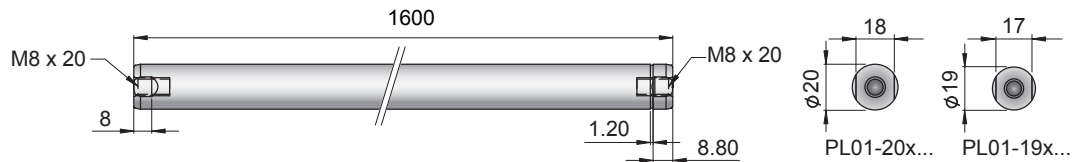

Standard Type	Slider Standard	PL01-20x1600/1520	0150-1344
Special Sliders	Heavy Duty Slider with WC/C-Coating	PL02-20x1600/1520	on request
	Hollow Slider hole diameter 6.5mm	PL01-20x1600/1520-L	on request
	High Clearance Slider d=19mm	PL01-19x1600/1520	on request

Connectors

Motor Connector Wiring		P01-37...-C		P01-37...-C20		P01-37...-C20	
Cable Length:							
P01-37x120...	1.5m						
P01-37x120...-C20	0.2m						
Ph 1+	red	A	1				
Ph 1-	pink	B	2				
Ph 2+	blue	C	3				
Ph 2-	grey	D	4				
+5VDC	white	E	5				
GND	inner Shield	F	6				
Sine	yellow	G	7				
Cosine	green	H	8				
Temp.	black	L	9				
Shield	outer Shield	Case	10				

Accessoires

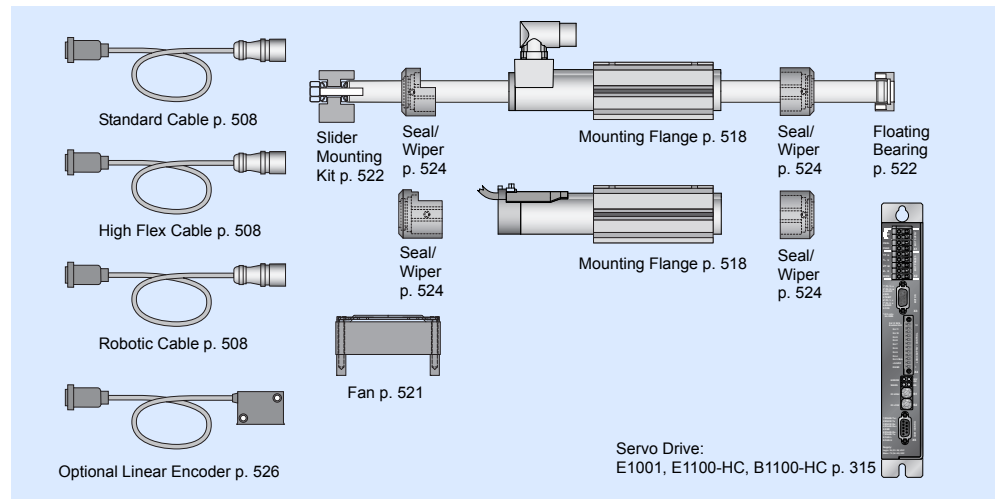

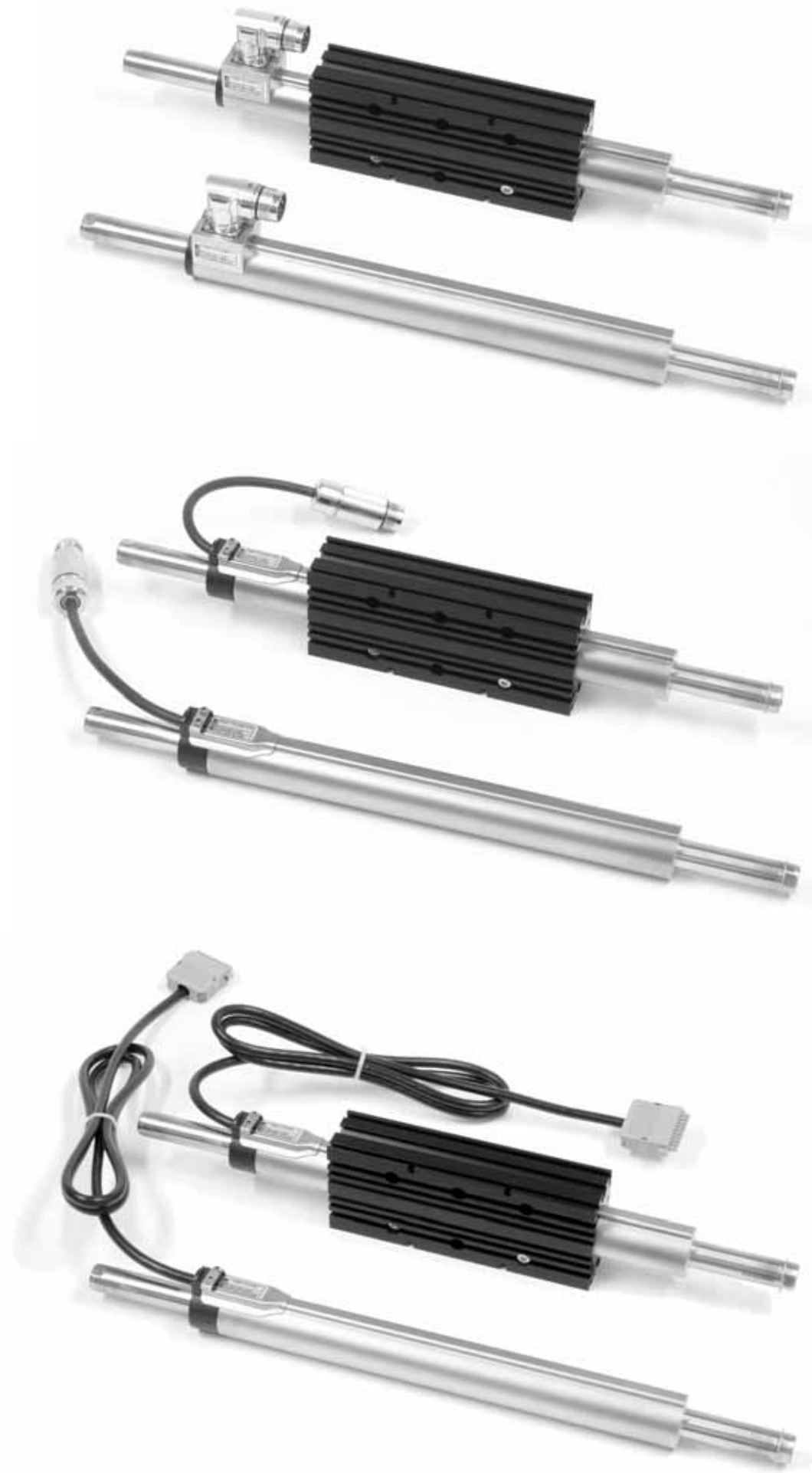

P01-37x240/100x100 112

P01-37x240/40x160 114

P01-37x240/60x260 116

P01-37x240/160x360 118

P01-37x240/260x460 120

P01-37x240/360x560 122

P01-37x240/460x660 124

P01-37x240/560x760 126

P01-37x240/660x860 128

P01-37x240/860x1060 130

P01-37x240/1060x1260 132

P01-37x240/1260x1460 134

Max. Stroke: 100mm
Peak Force: 180N

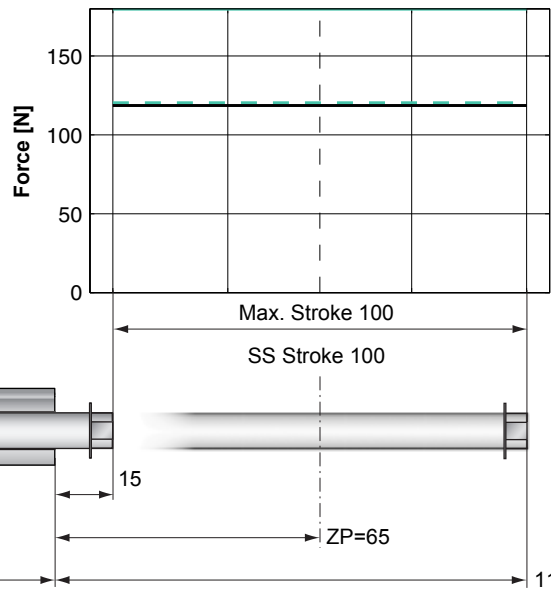

Standard Winding:
 — E1100-HC, 72VDC
 — E1100, 72VDC & E1001, 72VDC

Fast Winding:
 — E1100-HC, 72VDC
 - - E1100, 72VDC & E1001, 72VDC

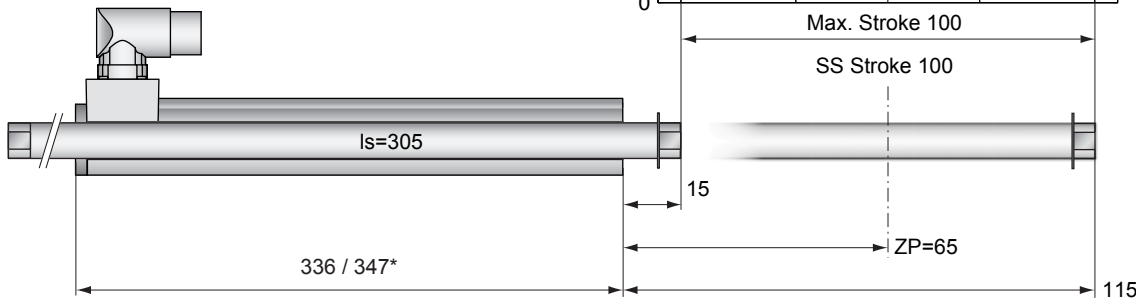

Dimensions in mm
 *Cable Type

Motor Specification

	P01-	Connector Type		Cable Type	
		Standard Winding 37x240/100x100-C	Fast Winding 37x240F/100x100-C	Standard Winding 37x240/100x100-P150 37x240/100x100-C20	Fast Winding 37x240F/100x100-C20
Extended Stroke ES	mm (in)	100 (3.94)	100 (3.94)	100 (3.94)	100 (3.94)
Standard Stroke SS	mm (in)	100 (3.94)	100 (3.94)	100 (3.94)	100 (3.94)
Peak Force E1100-HC	N (lbf)	119 (26.7)	180 (40.4)	119 (26.7)	180 (40.4)
Peak Force E1100 / E1001	N (lbf)	119 (26.7)	120 (27.1)	119 (26.7)	120 (27.1)
Cont. Force	N (lbf)	31 (7.0)	31 (7.0)	31 (7.0)	31 (7.0)
Cont. Force Fan cooling	N (lbf)	58 (13.1)	58 (13.1)	58 (13.1)	58 (13.1)
Border Force	%	100	100	100	100
Force Constant	N/A (lbf/A)	23.8 (5.35)	15.1 (3.38)	23.8 (5.35)	15.1 (3.38)
Max. Current @ 72VDC	A	5.0	11.9	5.0	11.9
Max. Current @ 48VDC	A	3.3	8.0	3.3	8.0
Max. Velocity @ 72VDC	m/s (in/s)	2.8 (110)	4.4 (173)	2.8 (110)	4.4 (173)
Max. Velocity @ 48VDC	m/s (in/s)	1.9 (73)	2.9 (116)	1.9 (73)	2.9 (116)
Phase Resist. 25/80 °C	Ohm	11.7/14.2	4.9/5.9	11.7/14.2	4.9/5.9
Phase Inductance	mH	6.0	2.4	6.0	2.4
Thermal Resistance	°K/W	2.3	2.2	2.3	2.2
Thermal Time Const.	sec	3400	3200	3400	3200
Stator Diameter	mm (in)	37 (1.46)	37 (1.46)	37 (1.46)	37 (1.46)
Stator Length	mm (in)	336 (13.23)	336 (13.23)	347 (13.66)	347 (13.66)
Stator Mass	g (lb)	1385 (3.05)	1385 (3.05)	1385 (3.05)	1385 (3.05)
Slider Diameter	mm (in)	20 (0.79)	20 (0.79)	20 (0.79)	20 (0.79)
Slider Length	mm (in)	305 (12.01)	305 (12.01)	305 (12.01)	305 (12.01)
Slider Mass	g (lb)	496 (1.09)	496 (1.09)	496 (1.09)	496 (1.09)
Position Repeatability	mm (in)	±0.05 (±0.0020)	±0.05 (±0.0020)	±0.05 (±0.0020)	±0.05 (±0.0020)
Linearity	%	±0.40	±0.40	±0.40	±0.40
Repeatability with EPS	mm (in)	±0.01 (±0.0004)	±0.01 (±0.0004)	±0.01 (±0.0004)	±0.01 (±0.0004)
Linearity with EPS	mm (in)	±0.01 (±0.0004)	±0.01 (±0.0004)	±0.01 (±0.0004)	±0.01 (±0.0004)

Position-Time Diagram

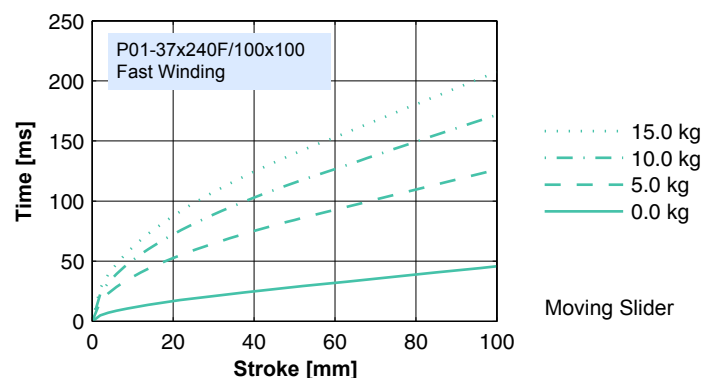
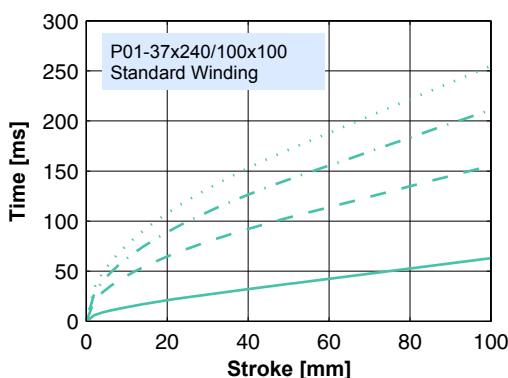

Connector Type

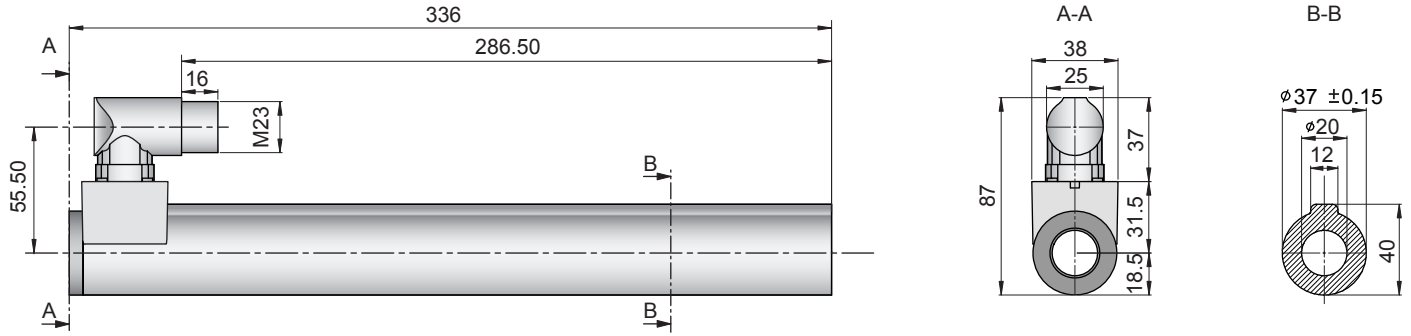

Linear Motor		Stator		Slider		
Type	Art.No	Type	Art. No.	Type	Art No.	
P01-37x240/100x100-C	-->	PS01-37x240-C	0150-1224	&	PL01-20x305/160	0150-1311
P01-37x240F/100x100-C	-->	PS01-37x240F-C	0150-1225	&	PL01-20x305/160	0150-1311

Cable Type

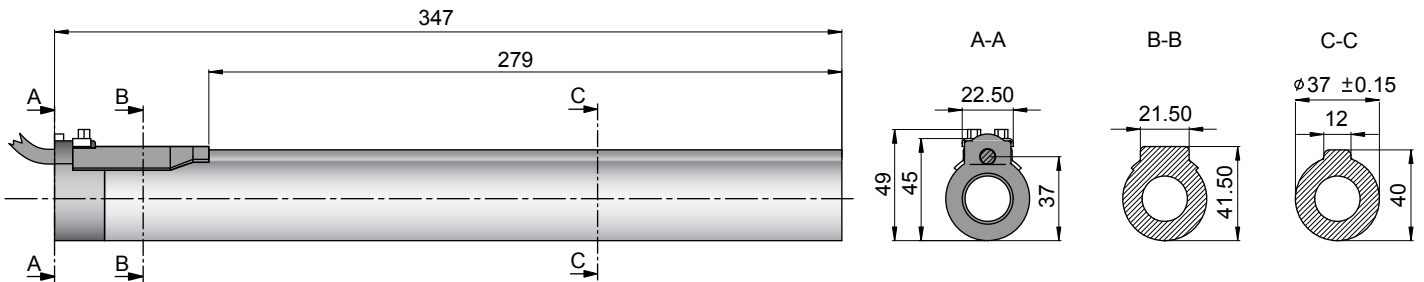

Linear Motor		Stator		Slider		
Type	Art.No	Type	Art. No.	Type	Art No.	
P01-37x240/100x100-P150	-->	PS01-37x240-P150	0150-1203	&	PL01-20x305/160	0150-1311
P01-37x240/100x100-C20	-->	PS01-37x240-C20	0150-1238	&	PL01-20x305/160	0150-1311
P01-37x240F/100x100-C20	-->	PS01-37x240F-C20	0150-1239	&	PL01-20x305/160	0150-1311

Slider

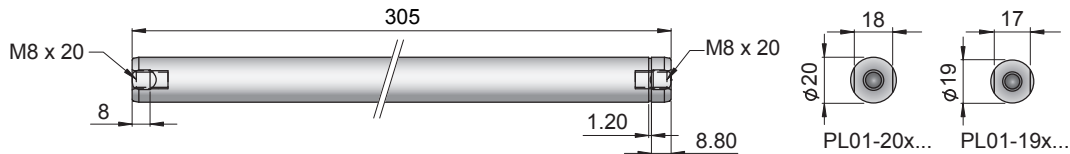

Standard Type	Slider Standard	PL01-20x305/160	0150-1311
Special Sliders	Heavy Duty Slider with WC/C-Coating	PL02-20x305/160	0150-1314
	Hollow Slider hole diameter 6.5mm	PL01-20x305/160-L	0150-1352
	High Clearance Slider d=19mm, m=448g	PL01-19x305/160	0150-1450

Connectors

Motor Connector Wiring

Cable Length:
P01-37x240... 1.5m
P01-37x240...-C20 0.2m

Ph	Color	Terminal	Case
Ph 1+	red	A	1
Ph 1-	pink	B	2
Ph 2+	blue	C	3
Ph 2-	grey	D	4
+5VDC	white	E	5
GND	inner Shield	F	6
Sine	yellow	G	7
Cosine	green	H	8
Temp.	black	L	9
Shield	outer Shield	Case	10

Accessoires

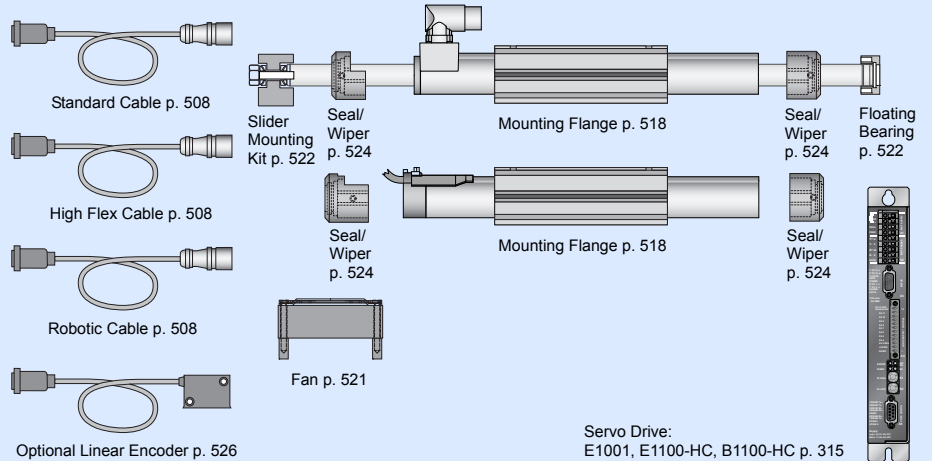

Max. Stroke: 160mm
Peak Force: 257N

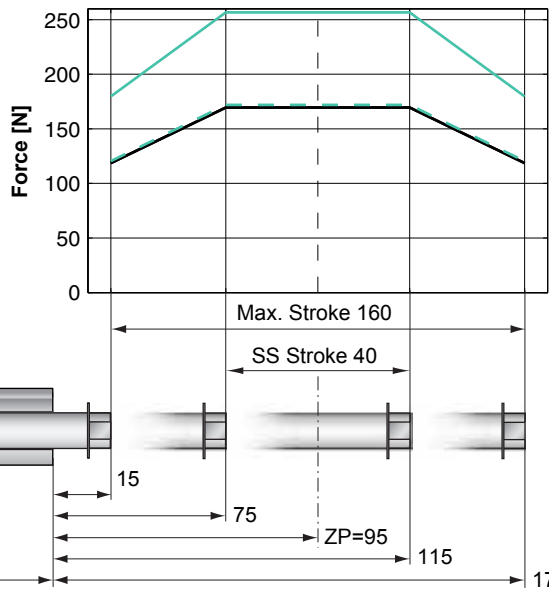

Standard Winding:
 — E1100–HC, 72VDC
 — E1100, 72VDC & E1001, 72VDC

Fast Winding:
 — E1100–HC, 72VDC
 - - E1100, 72VDC & E1001, 72VDC

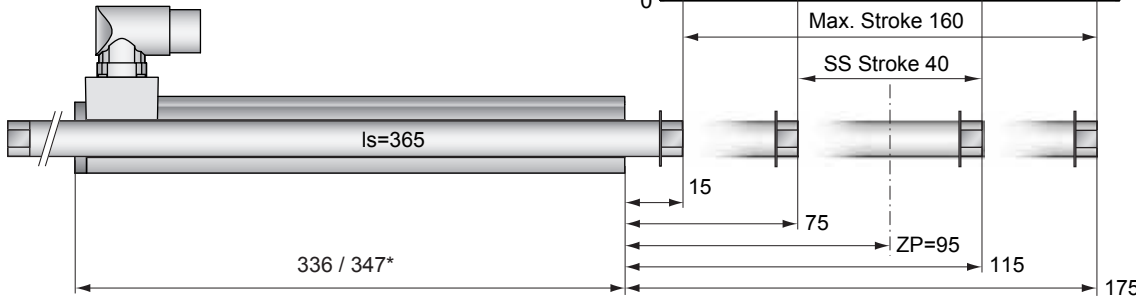

Dimensions in mm
 *Cable Type

Motor Specification

	P01-	Connector Type		Cable Type	
		Standard Winding 37x240/40x160-C	Fast Winding 37x240F/40x160-C	Standard Winding 37x240/40x160-P150 37x240/40x160-C20	Fast Winding 37x240F/40x160-C20
Extended Stroke ES	mm (in)	160 (6.30)	160 (6.30)	160 (6.30)	160 (6.30)
Standard Stroke SS	mm (in)	40 (1.57)	40 (1.57)	40 (1.57)	40 (1.57)
Peak Force E1100-HC	N (lbf)	169 (38.1)	257 (57.7)	169 (38.1)	257 (57.7)
Peak Force E1100 / E1001	N (lbf)	169 (38.1)	172 (38.7)	169 (38.1)	172 (38.7)
Cont. Force	N (lbf)	44 (10.0)	44 (10.0)	44 (10.0)	44 (10.0)
Cont. Force Fan cooling	N (lbf)	83 (18.7)	83 (18.7)	83 (18.7)	83 (18.7)
Border Force	%	70	70	70	70
Force Constant	N/A (lbf/A)	34.0 (7.64)	21.5 (4.83)	34.0 (7.64)	21.5 (4.83)
Max. Current @ 72VDC	A	5.0	11.9	5.0	11.9
Max. Current @ 48VDC	A	3.3	8.0	3.3	8.0
Max. Velocity @ 72VDC	m/s (in/s)	1.9 (77)	3.1 (121)	1.9 (77)	3.1 (121)
Max. Velocity @ 48VDC	m/s (in/s)	1.3 (51)	2.1 (81)	1.3 (51)	2.1 (81)
Phase Resist. 25/80 °C	Ohm	11.7/14.2	4.9/5.9	11.7/14.2	4.9/5.9
Phase Inductance	mH	6.0	2.4	6.0	2.4
Thermal Resistance	°K/W	2.3	2.2	2.3	2.2
Thermal Time Const.	sec	3400	3200	3400	3200
Stator Diameter	mm (in)	37 (1.46)	37 (1.46)	37 (1.46)	37 (1.46)
Stator Length	mm (in)	336 (13.23)	336 (13.23)	347 (13.66)	347 (13.66)
Stator Mass	g (lb)	1385 (3.05)	1385 (3.05)	1385 (3.05)	1385 (3.05)
Slider Diameter	mm (in)	20 (0.79)	20 (0.79)	20 (0.79)	20 (0.79)
Slider Length	mm (in)	365 (14.37)	365 (14.37)	365 (14.37)	365 (14.37)
Slider Mass	g (lb)	635 (1.40)	635 (1.40)	635 (1.40)	635 (1.40)
Position Repeatability	mm (in)	±0.05 (±0.0020)	±0.05 (±0.0020)	±0.05 (±0.0020)	±0.05 (±0.0020)
Linearity	%	±0.30	±0.30	±0.30	±0.30
Repeatability with EPS	mm (in)	±0.01 (±0.0004)	±0.01 (±0.0004)	±0.01 (±0.0004)	±0.01 (±0.0004)
Linearity with EPS	mm (in)	±0.01 (±0.0004)	±0.01 (±0.0004)	±0.01 (±0.0004)	±0.01 (±0.0004)

Position-Time Diagram

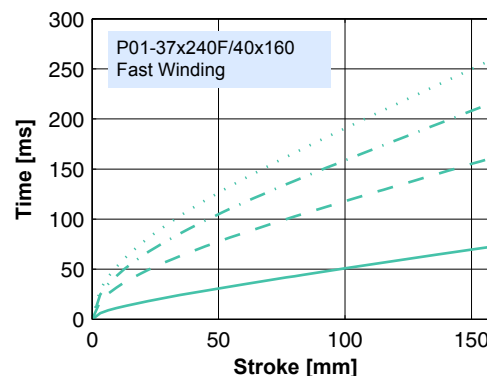
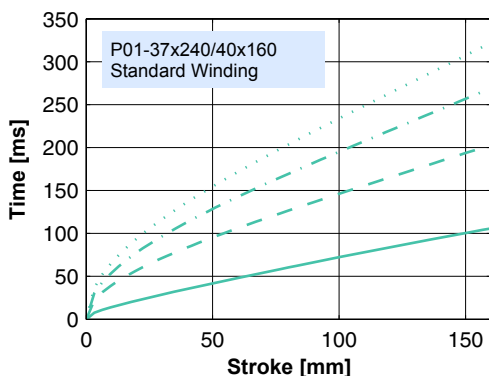

Moving Slider

Moving Slider

Connector Type

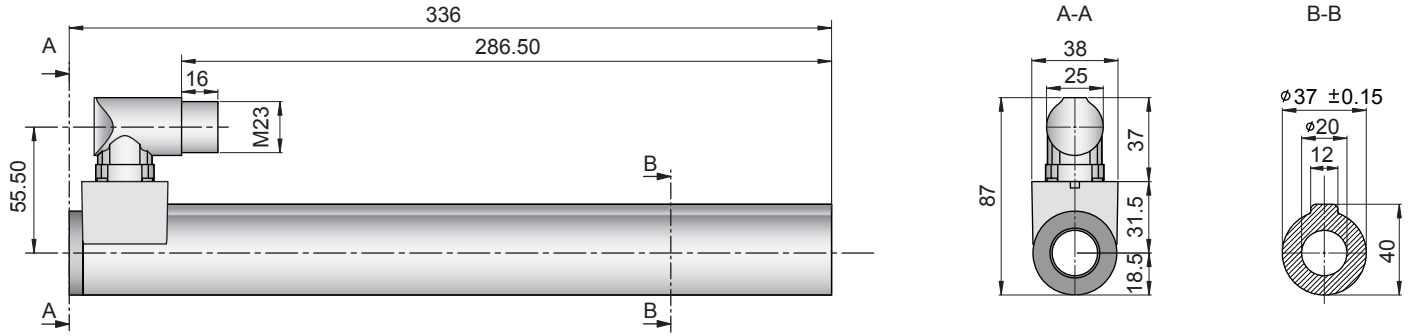

Linear Motor		Stator		Slider		
Type	Art.No	Type	Art. No.	Type	Art No.	
P01-37x240/40x160-C	-->	PS01-37x240-C	0150-1224	&	PL01-20x365/220	0150-1312
P01-37x240F/40x160-C	-->	PS01-37x240F-C	0150-1225	&	PL01-20x365/220	0150-1312

Cable Type

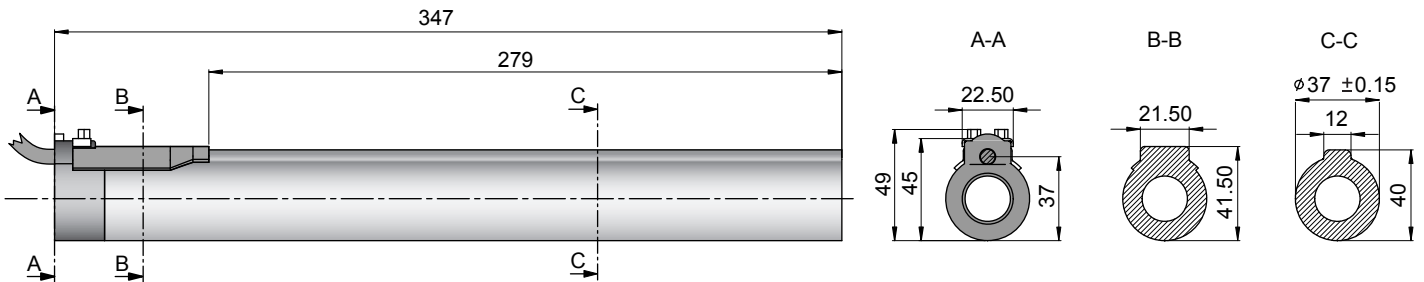

Linear Motor		Stator		Slider		
Type	Art.No	Type	Art. No.	Type	Art No.	
P01-37x240/40x160-P150	-->	PS01-37x240-P150	0150-1203	&	PL01-20x365/220	0150-1312
P01-37x240/40x160-C20	-->	PS01-37x240-C20	0150-1238	&	PL01-20x365/220	0150-1312
P01-37x240F/40x160-C20	-->	PS01-37x240F-C20	0150-1239	&	PL01-20x365/220	0150-1312

Slider

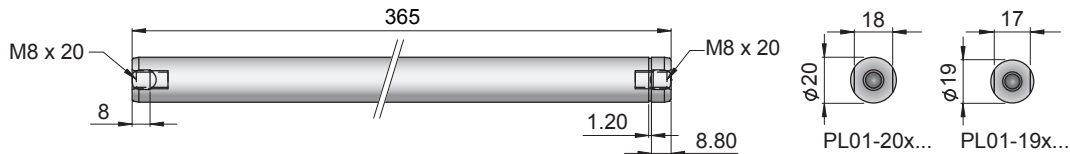

Standard Type	Slider Standard	PL01-20x365/220	0150-1312
Special Sliders	Heavy Duty Slider with WC/C-Coating	PL02-20x365/220	0150-1315
	Hollow Slider hole diameter 6.5mm	PL01-20x365/220-L	0150-1353
	High Clearance Slider d=19mm, m=573g	PL01-19x365/220	0150-1451

Connectors

Motor Connector Wiring		Cable Length:		P01-37...-C		P01-37...-C20		P01-37...	
Ph 1+	red	A	1	1.5m					
Ph 1-	pink	B	2	0.2m					
Ph 2+	blue	C	3						
Ph 2-	grey	D	4						
+5VDC	white	E	5						
GND	inner Shield	F	6						
Sine	yellow	G	7						
Cosine	green	H	8						
Temp.	black	L	9						
Shield	outer Shield	Case	10						

Accessoires

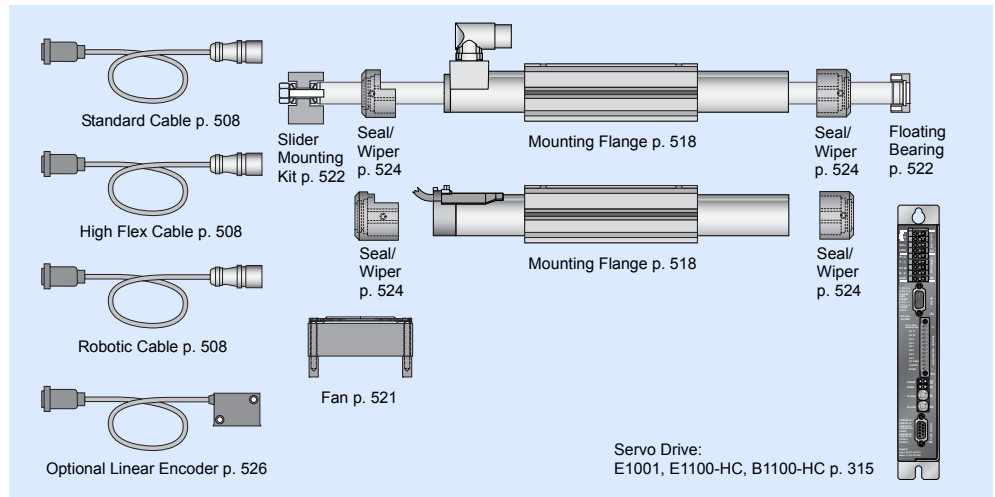

Max. Stroke: 260mm
Peak Force: 308N

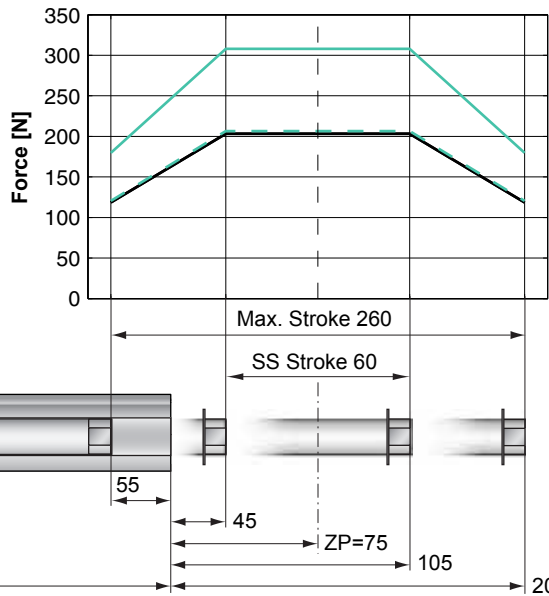

Standard Winding:
 — E1100-HC, 72VDC
 — E1100, 72VDC & E1001, 72VDC

Fast Winding:
 — E1100-HC, 72VDC
 - - E1100, 72VDC & E1001, 72VDC

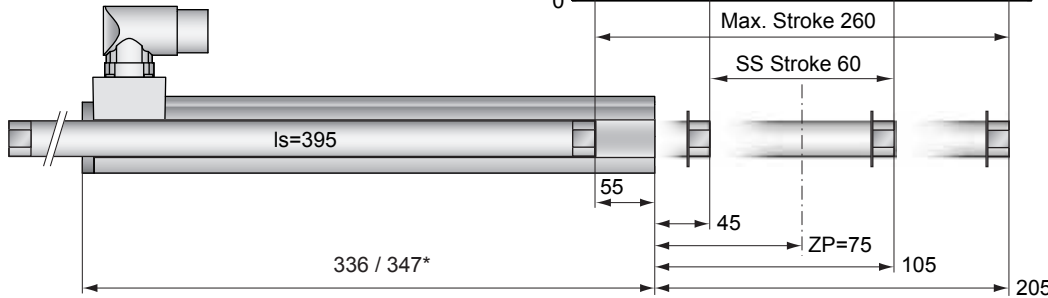

Dimensions in mm
 *Cable Type

Motor Specification

	P01-	Connector Type		Cable Type	
		Standard Winding 37x240/60x260-C	Fast Winding 37x240F/60x260-C	Standard Winding 37x240/60x260-P150 37x240/60x260-C20	Fast Winding 37x240F/60x260-C20
Extended Stroke ES	mm (in)	260 (10.24)	260 (10.24)	260 (10.24)	260 (10.24)
Standard Stroke SS	mm (in)	60 (2.36)	60 (2.36)	60 (2.36)	60 (2.36)
Peak Force E1100-HC	N (lbf)	203 (45.7)	308 (69.2)	203 (45.7)	308 (69.2)
Peak Force E1100 / E1001	N (lbf)	203 (45.7)	206 (46.4)	203 (45.7)	206 (46.4)
Cont. Force	N (lbf)	53 (12.0)	53 (12.0)	53 (12.0)	53 (12.0)
Cont. Force Fan cooling	N (lbf)	100 (22.4)	100 (22.4)	100 (22.4)	100 (22.4)
Border Force	%	58	58	58	58
Force Constant	N/A (lbf/A)	40.8 (9.17)	25.8 (5.80)	40.8 (9.17)	25.8 (5.80)
Max. Current @ 72VDC	A	5.0	11.9	5.0	11.9
Max. Current @ 48VDC	A	3.3	8.0	3.3	8.0
Max. Velocity @ 72VDC	m/s (in/s)	1.6 (64)	2.6 (101)	1.6 (64)	2.6 (101)
Max. Velocity @ 48VDC	m/s (in/s)	1.1 (43)	1.7 (67)	1.1 (43)	1.7 (67)
Phase Resist. 25/80 °C	Ohm	11.7/14.2	4.9/5.9	11.7/14.2	4.9/5.9
Phase Inductance	mH	6.0	2.4	6.0	2.4
Thermal Resistance	°K/W	2.3	2.2	2.3	2.2
Thermal Time Const.	sec	3400	3200	3400	3200
Stator Diameter	mm (in)	37 (1.46)	37 (1.46)	37 (1.46)	37 (1.46)
Stator Length	mm (in)	336 (13.23)	336 (13.23)	347 (13.66)	347 (13.66)
Stator Mass	g (lb)	1385 (3.05)	1385 (3.05)	1385 (3.05)	1385 (3.05)
Slider Diameter	mm (in)	20 (0.79)	20 (0.79)	20 (0.79)	20 (0.79)
Slider Length	mm (in)	395 (15.55)	395 (15.55)	395 (15.55)	395 (15.55)
Slider Mass	g (lb)	829 (1.83)	829 (1.83)	829 (1.83)	829 (1.83)
Position Repeatability	mm (in)	±0.05 (±0.0020)	±0.05 (±0.0020)	±0.05 (±0.0020)	±0.05 (±0.0020)
Linearity	%	±0.20	±0.20	±0.20	±0.20
Repeatability with EPS	mm (in)	±0.01 (±0.0004)	±0.01 (±0.0004)	±0.01 (±0.0004)	±0.01 (±0.0004)
Linearity with EPS	mm (in)	±0.01 (±0.0004)	±0.01 (±0.0004)	±0.01 (±0.0004)	±0.01 (±0.0004)

Position-Time Diagram

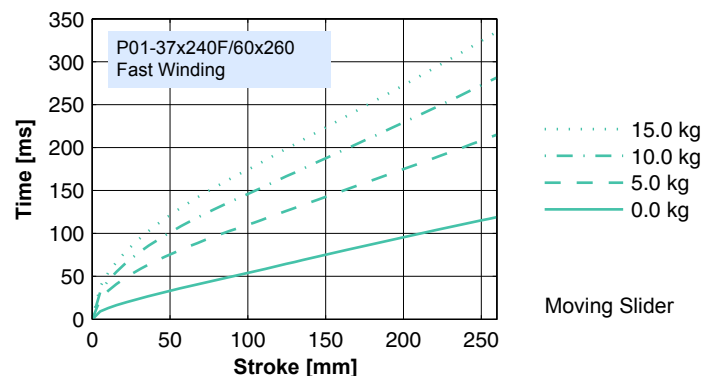
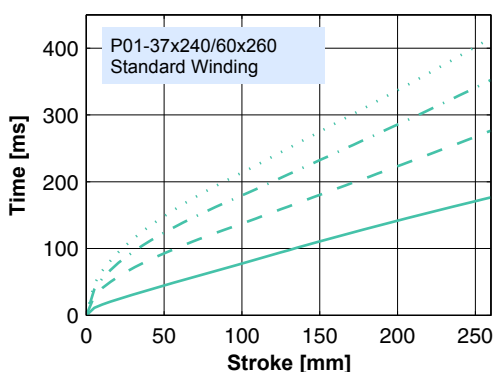

Connector Type

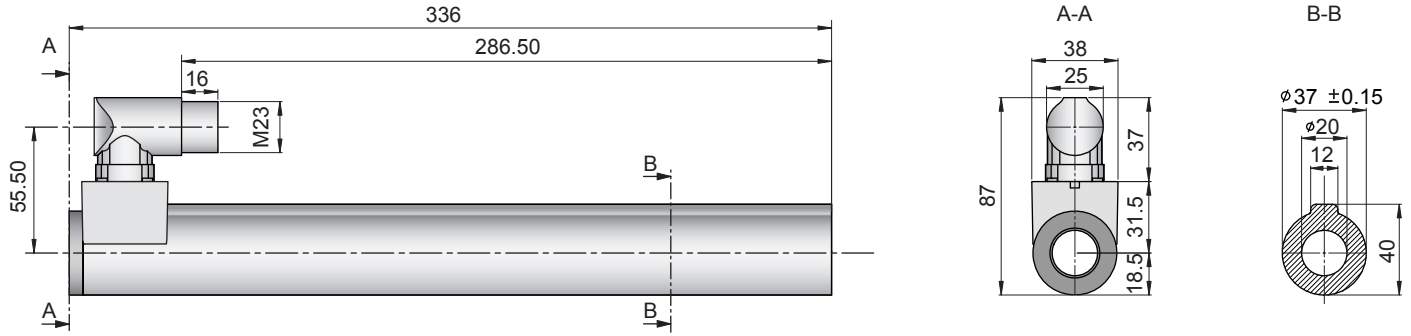

Linear Motor		Stator		Slider	
Type	Art.No	Type	Art. No.	Type	Art No.
P01-37x240/60x260-C	-->	PS01-37x240-C	0150-1224	& PL01-20x395/320	0150-1318
P01-37x240F/60x260-C	-->	PS01-37x240F-C	0150-1225	& PL01-20x395/320	0150-1318

Cable Type

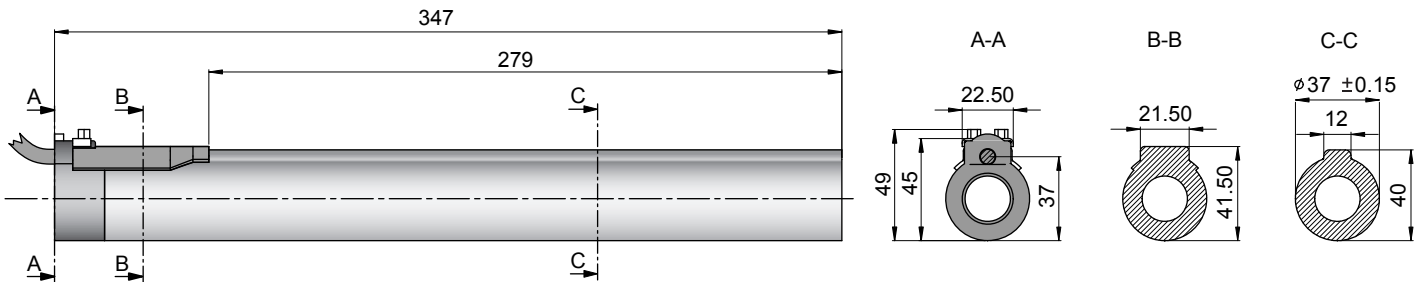

Linear Motor		Stator		Slider	
Type	Art.No	Type	Art. No.	Type	Art No.
P01-37x240/60x260-P150	-->	PS01-37x240-P150	0150-1203	& PL01-20x395/320	0150-1318
P01-37x240/60x260-C20	-->	PS01-37x240-C20	0150-1238	& PL01-20x395/320	0150-1318
P01-37x240F/60x260-C20	-->	PS01-37x240F-C20	0150-1239	& PL01-20x395/320	0150-1318

Slider

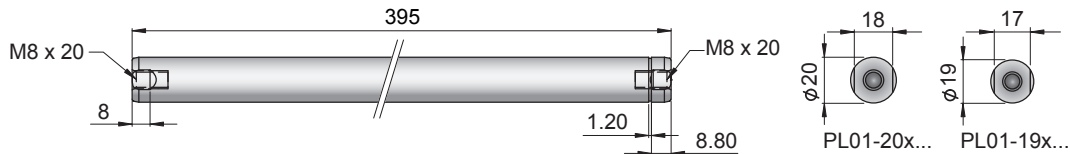

Standard Type	Slider Standard	PL01-20x395/320	0150-1318
Special Sliders	Heavy Duty Slider with WC/C-Coating	PL02-20x395/320	0150-1319
	Hollow Slider hole diameter 6.5mm	PL01-20x395/320-L	0150-1354
	High Clearance Slider d=19mm, m=748g	PL01-19x395/320	0150-1452

Connectors

Motor Connector Wiring

Cable Length:
P01-37x240... 1.5m
P01-37x240...-C20 0.2m

Pin	Color	Label	Case
Ph 1+	red	A	1
Ph 1-	pink	B	2
Ph 2+	blue	C	3
Ph 2-	grey	D	4
+5VDC	white	E	5
GND	inner Shield	F	6
Sine	yellow	G	7
Cosine	green	H	8
Temp.	black	L	9
Shield	outer Shield	Case	10

Accessoires

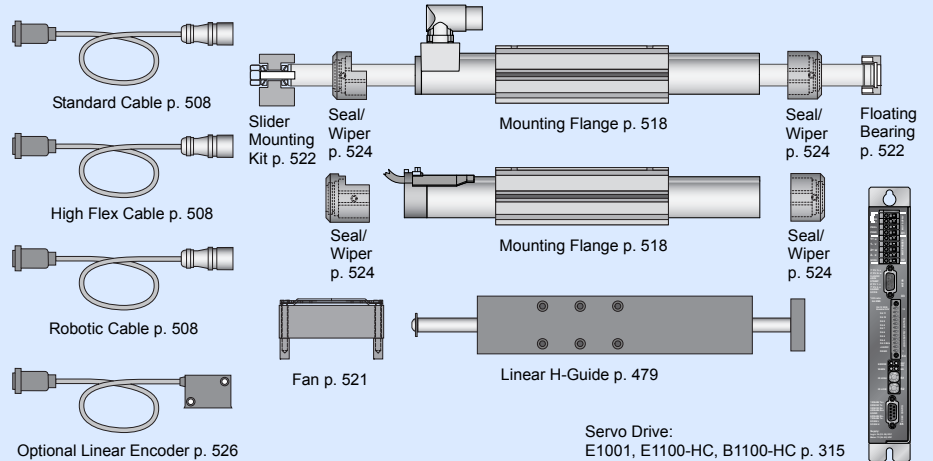

Servo Drive:
E1001, E1100-HC, B1100-HC p. 315

Max. Stroke: 360mm
Peak Force: 308N

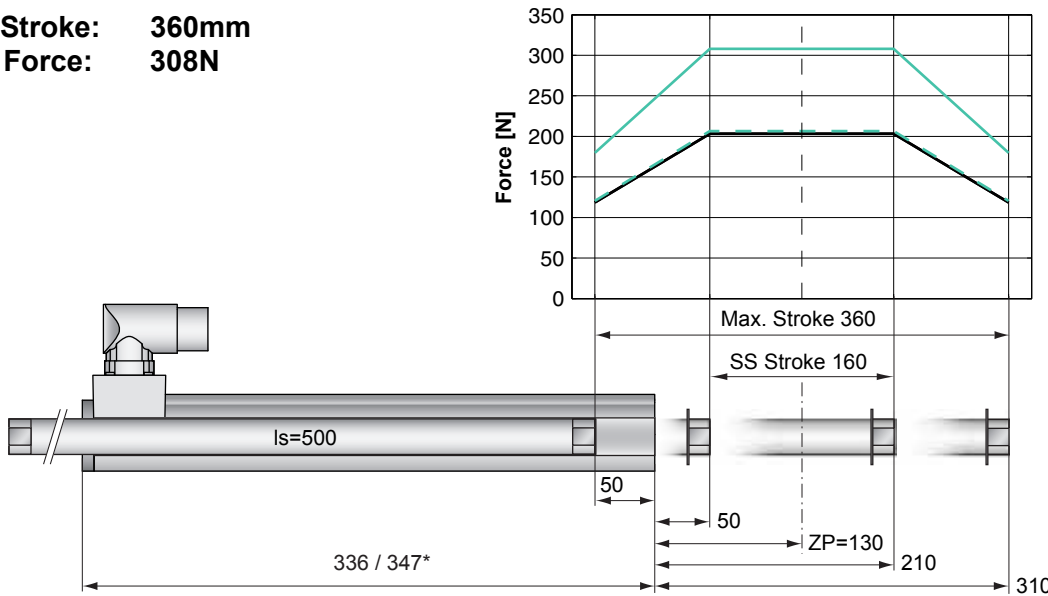

Dimensions in mm
 *Cable Type

Motor Specification

	P01-	Connector Type		Cable Type	
		Standard Winding 37x240/160x360-C	Fast Winding 37x240F/160x360-C	Standard Winding 37x240/160x360-P150 37x240/160x360-C20	Fast Winding 37x240F/160x360-C20
Extended Stroke ES	mm (in)	360 (14.17)	360 (14.17)	360 (14.17)	360 (14.17)
Standard Stroke SS	mm (in)	160 (6.30)	160 (6.30)	160 (6.30)	160 (6.30)
Peak Force E1100-HC	N (lbf)	203 (45.7)	308 (69.2)	203 (45.7)	308 (69.2)
Peak Force E1100 / E1001	N (lbf)	203 (45.7)	206 (46.4)	203 (45.7)	206 (46.4)
Cont. Force	N (lbf)	53 (12.0)	53 (12.0)	53 (12.0)	53 (12.0)
Cont. Force Fan cooling	N (lbf)	100 (22.4)	100 (22.4)	100 (22.4)	100 (22.4)
Border Force	%	58	58	58	58
Force Constant	N/A (lbf/A)	40.8 (9.17)	25.8 (5.80)	40.8 (9.17)	25.8 (5.80)
Max. Current @ 72VDC	A	5.0	11.9	5.0	11.9
Max. Current @ 48VDC	A	3.3	8.0	3.3	8.0
Max. Velocity @ 72VDC	m/s (in/s)	1.6 (64)	2.6 (101)	1.6 (64)	2.6 (101)
Max. Velocity @ 48VDC	m/s (in/s)	1.1 (43)	1.7 (67)	1.1 (43)	1.7 (67)
Phase Resist. 25/80 °C	Ohm	11.7/14.2	4.9/5.9	11.7/14.2	4.9/5.9
Phase Inductance	mH	6.0	2.4	6.0	2.4
Thermal Resistance	°K/W	2.3	2.2	2.3	2.2
Thermal Time Const.	sec	3400	3200	3400	3200
Stator Diameter	mm (in)	37 (1.46)	37 (1.46)	37 (1.46)	37 (1.46)
Stator Length	mm (in)	336 (13.23)	336 (13.23)	347 (13.66)	347 (13.66)
Stator Mass	g (lb)	1385 (3.05)	1385 (3.05)	1385 (3.05)	1385 (3.05)
Slider Diameter	mm (in)	20 (0.79)	20 (0.79)	20 (0.79)	20 (0.79)
Slider Length	mm (in)	500 (19.69)	500 (19.69)	500 (19.69)	500 (19.69)
Slider Mass	g (lb)	1064 (2.35)	1064 (2.35)	1064 (2.35)	1064 (2.35)
Position Repeatability	mm (in)	±0.05 (±0.0020)	±0.05 (±0.0020)	±0.05 (±0.0020)	±0.05 (±0.0020)
Linearity	%	±0.20	±0.20	±0.20	±0.20
Repeatability with EPS	mm (in)	±0.01 (±0.0004)	±0.01 (±0.0004)	±0.01 (±0.0004)	±0.01 (±0.0004)
Linearity with EPS	mm (in)	±0.01 (±0.0004)	±0.01 (±0.0004)	±0.01 (±0.0004)	±0.01 (±0.0004)

Position-Time Diagram

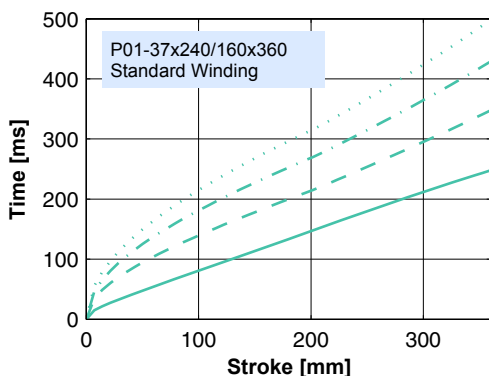

15.0 kg
 10.0 kg
 5.0 kg
 0.0 kg

Moving Slider

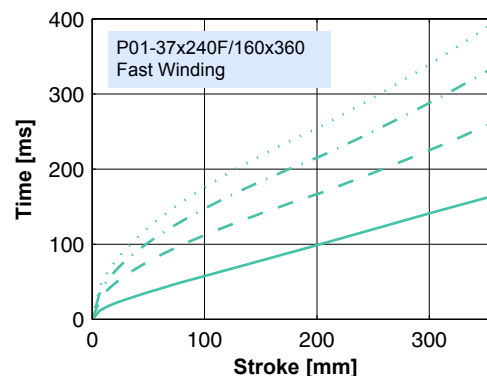

15.0 kg
 10.0 kg
 5.0 kg
 0.0 kg

Moving Slider

Connector Type

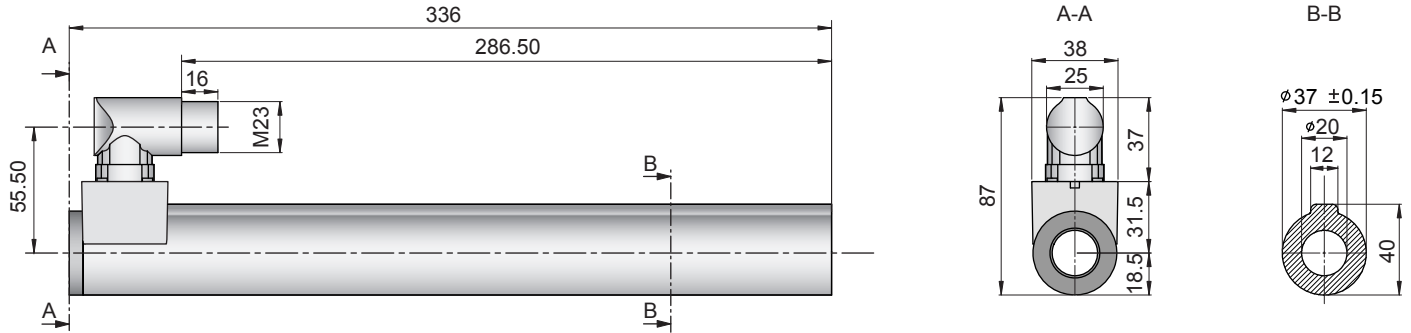

Linear Motor		Stator		Slider	
Type	Art.No	Type	Art. No.	Type	Art No.
P01-37x240/160x360-C	-->	PS01-37x240-C	0150-1224	& PL01-20x500/420	0150-1328
P01-37x240F/160x360-C	-->	PS01-37x240F-C	0150-1225	& PL01-20x500/420	0150-1328

Cable Type

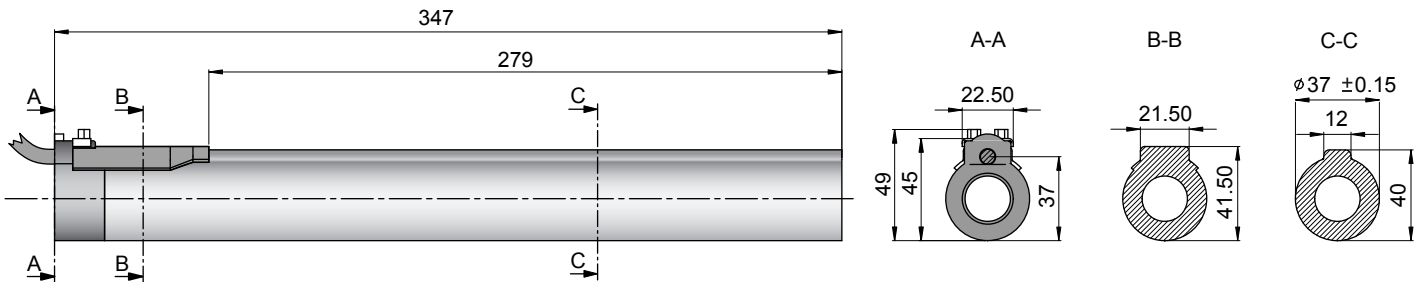

Linear Motor		Stator		Slider	
Type	Art.No	Type	Art. No.	Type	Art No.
P01-37x240/160x360-P150	-->	PS01-37x240-P150	0150-1203	& PL01-20x500/420	0150-1328
P01-37x240/160x360-C20	-->	PS01-37x240-C20	0150-1238	& PL01-20x500/420	0150-1328
P01-37x240F/160x360-C20	-->	PS01-37x240F-C20	0150-1239	& PL01-20x500/420	0150-1328

Slider

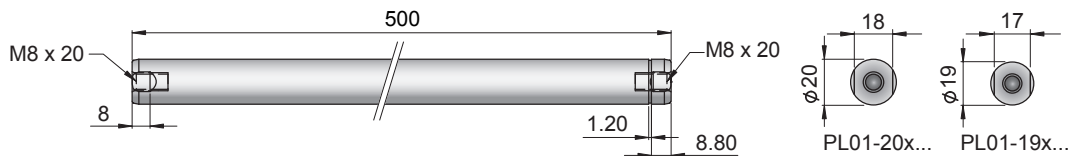

Standard Type	Slider Standard	PL01-20x500/420	0150-1328
Special Sliders	Heavy Duty Slider with WC/C-Coating	PL02-20x500/420	0150-1329
	Hollow Slider hole diameter 6.5mm	PL01-20x500/420-L	0150-1358
	High Clearance Slider d=19mm, m=960g	PL01-19x500/420	0150-1455

Connectors

Motor Connector Wiring

Cable Length:
P01-37x240... 1.5m
P01-37x240...-C20 0.2m

		P01-37...-C P01-37...-C20	P01-37...
Ph 1+	red	A	1
Ph 1-	pink	B	2
Ph 2+	blue	C	3
Ph 2-	grey	D	4
+5VDC	white	E	5
GND	inner Shield	F	6
Sine	yellow	G	7
Cosine	green	H	8
Temp.	black	L	9
Shield	outer Shield	Case	10

Accessoires

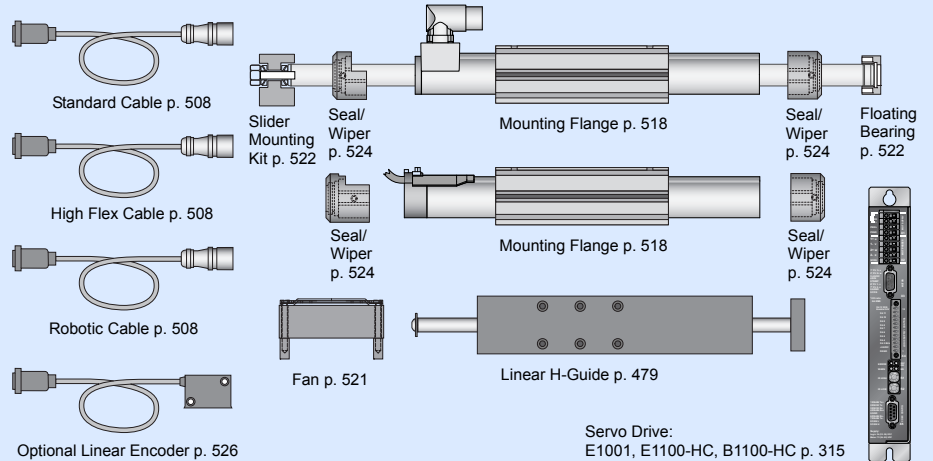

Servo Drive:
E1001, E1100-HC, B1100-HC p. 315

Max. Stroke: 460mm
Peak Force: 308N

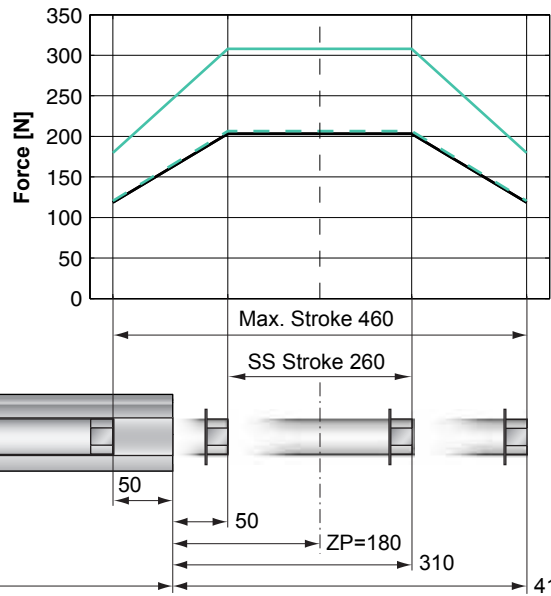

Standard Winding:
 — E1100–HC, 72VDC
 — E1100, 72VDC & E1001, 72VDC

Fast Winding:
 — E1100–HC, 72VDC
 - - E1100, 72VDC & E1001, 72VDC

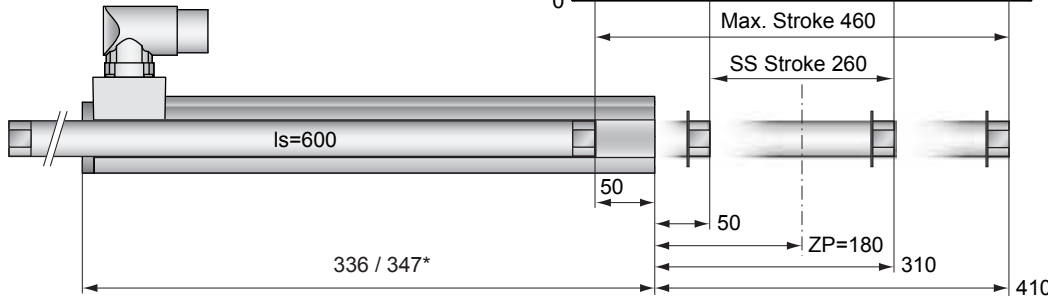

Dimensions in mm
 *Cable Type

Motor Specification

	Connector Type	Cable Type	
		Standard Winding	Fast Winding
		37x240/260x460-C	37x240F/260x460-C
	P01-	37x240/260x460-C	37x240/260x460-P150
			37x240/260x460-C20
			37x240F/260x460-C20
Extended Stroke ES	mm (in)	460 (18.11)	460 (18.11)
Standard Stroke SS	mm (in)	260 (10.24)	260 (10.24)
Peak Force E1100-HC	N (lbf)	203 (45.7)	308 (69.2)
Peak Force E1100 / E1001	N (lbf)	203 (45.7)	206 (46.4)
Cont. Force	N (lbf)	53 (12.0)	53 (12.0)
Cont. Force Fan cooling	N (lbf)	100 (22.4)	100 (22.4)
Border Force	%	58	58
Force Constant	N/A (lbf/A)	40.8 (9.17)	25.8 (5.80)
Max. Current @ 72VDC	A	5.0	11.9
Max. Current @ 48VDC	A	3.3	8.0
Max. Velocity @ 72VDC	m/s (in/s)	1.6 (64)	2.6 (101)
Max. Velocity @ 48VDC	m/s (in/s)	1.1 (43)	1.7 (67)
Phase Resist. 25/80 °C	Ohm	11.7/14.2	4.9/5.9
Phase Inductance	mH	6.0	2.4
Thermal Resistance	°K/W	2.3	2.2
Thermal Time Const.	sec	3400	3200
Stator Diameter	mm (in)	37 (1.46)	37 (1.46)
Stator Length	mm (in)	336 (13.23)	336 (13.23)
Stator Mass	g (lb)	1385 (3.05)	1385 (3.05)
Slider Diameter	mm (in)	20 (0.79)	20 (0.79)
Slider Length	mm (in)	600 (23.62)	600 (23.62)
Slider Mass	g (lb)	1297 (2.86)	1297 (2.86)
Position Repeatability	mm (in)	±0.05 (±0.0020)	±0.05 (±0.0020)
Linearity	%	±0.15	±0.15
Repeatability with EPS	mm (in)	±0.01 (±0.0004)	±0.01 (±0.0004)
Linearity with EPS	mm (in)	±0.01 (±0.0004)	±0.01 (±0.0004)

Position-Time Diagram

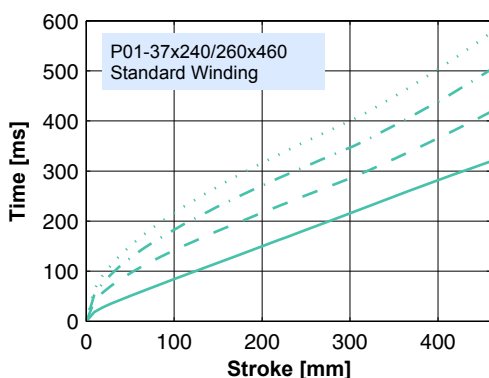

15.0 kg
 10.0 kg
 5.0 kg
 0.0 kg

Moving Slider

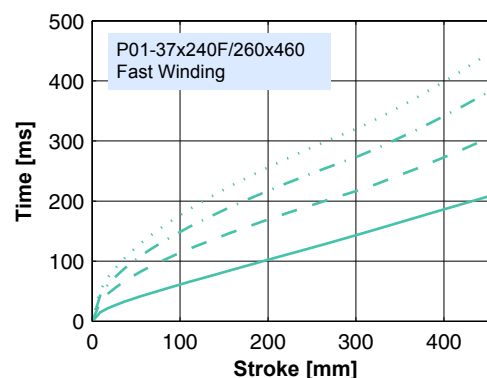

15.0 kg
 10.0 kg
 5.0 kg
 0.0 kg

Moving Slider

Connector Type

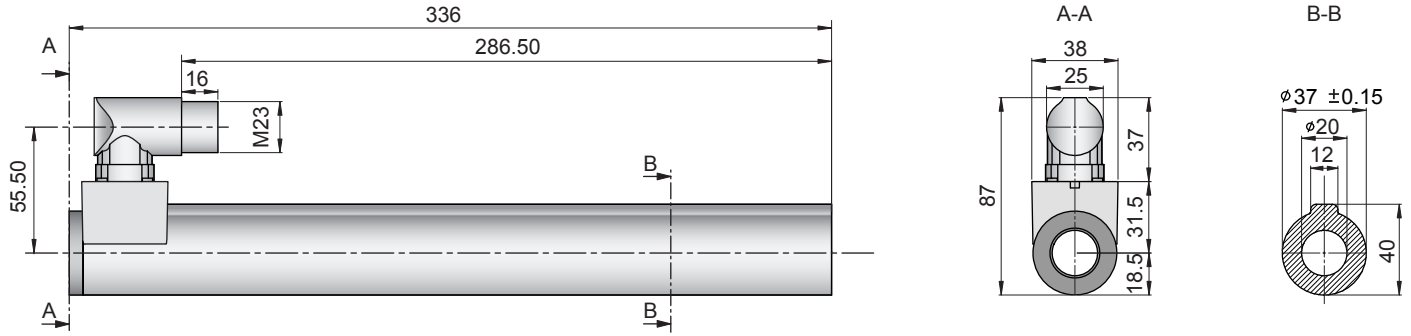

Linear Motor		Stator		Slider		
Type	Art.No	Type	Art. No.	Type	Art No.	
P01-37x240/260x460-C	-->	PS01-37x240-C	0150-1224	&	PL01-20x600/520	0150-1330
P01-37x240F/260x460-C	-->	PS01-37x240F-C	0150-1225	&	PL01-20x600/520	0150-1330

Cable Type

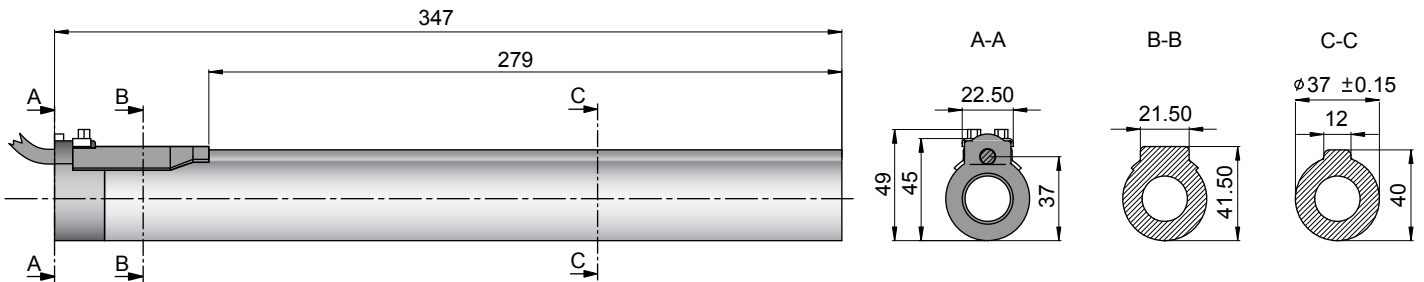

Linear Motor		Stator		Slider		
Type	Art.No	Type	Art. No.	Type	Art No.	
P01-37x240/260x460-P150	-->	PS01-37x240-P150	0150-1203	&	PL01-20x600/520	0150-1330
P01-37x240/260x460-C20	-->	PS01-37x240-C20	0150-1238	&	PL01-20x600/520	0150-1330
P01-37x240F/260x460-C20	-->	PS01-37x240F-C20	0150-1239	&	PL01-20x600/520	0150-1330

Slider

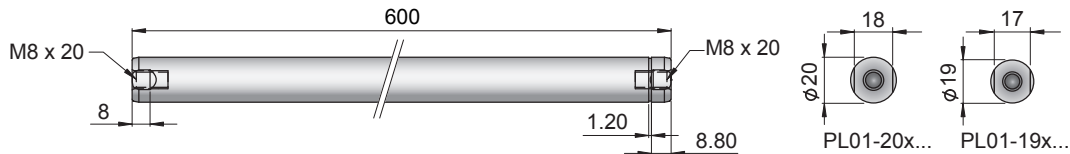

Standard Type	Slider Standard	PL01-20x600/520	0150-1330
Special Sliders	Heavy Duty Slider with WC/C-Coating	PL02-20x600/520	0150-1331
	Hollow Slider hole diameter 6.5mm	PL01-20x600/520-L	0150-1359
	High Clearance Slider d=19mm, m=1171g	PL01-19x600/520	0150-1456

Connectors

Motor Connector Wiring		P01-37...-C		P01-37...-C20		P01-37...	
Cable Length:							
P01-37x240...	1.5m						
P01-37x240...-C20	0.2m						
Ph 1+	red	A	1				
Ph 1-	pink	B	2				
Ph 2+	blue	C	3				
Ph 2-	grey	D	4				
+5VDC	white	E	5				
GND	inner Shield	F	6				
Sine	yellow	G	7				
Cosine	green	H	8				
Temp.	black	L	9				
Shield	outer Shield	Case	10				

Accessoires

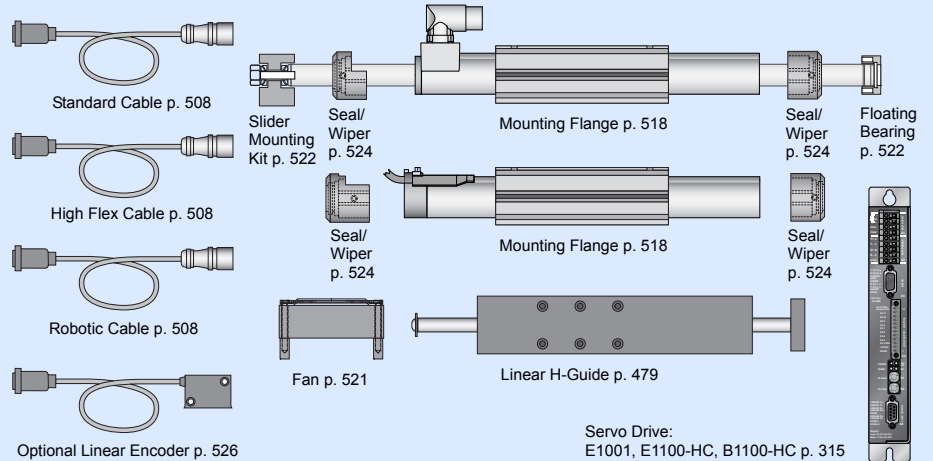

Max. Stroke: 560mm
Peak Force: 308N

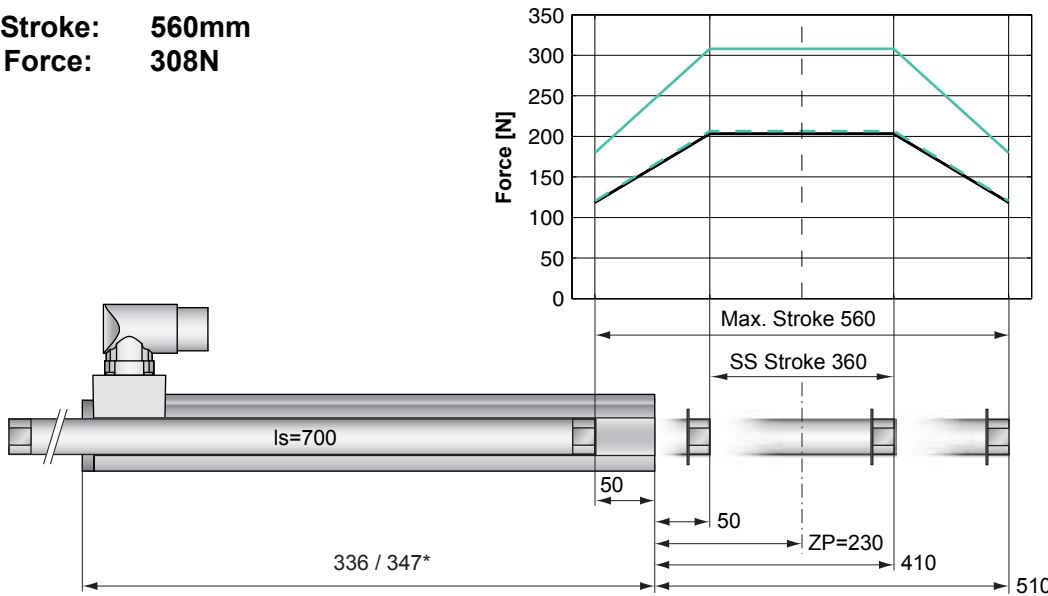

Standard Winding:
 — E1100-HC, 72VDC
 - - E1100, 72VDC & E1001, 72VDC

Fast Winding:
 — E1100-HC, 72VDC
 - - E1100, 72VDC & E1001, 72VDC

Dimensions in mm
 *Cable Type

Motor Specification

	P01-	Connector Type		Cable Type	
		Standard Winding 37x240/360x560-C	Fast Winding 37x240F/360x560-C	Standard Winding 37x240/360x560-P150 37x240/360x560-C20	Fast Winding 37x240F/360x560-C20
Extended Stroke ES	mm (in)	560 (22.05)	560 (22.05)	560 (22.05)	560 (22.05)
Standard Stroke SS	mm (in)	360 (14.17)	360 (14.17)	360 (14.17)	360 (14.17)
Peak Force E1100-HC	N (lbf)	203 (45.7)	308 (69.2)	203 (45.7)	308 (69.2)
Peak Force E1100 / E1001	N (lbf)	203 (45.7)	206 (46.4)	203 (45.7)	206 (46.4)
Cont. Force	N (lbf)	53 (12.0)	53 (12.0)	53 (12.0)	53 (12.0)
Cont. Force Fan cooling	N (lbf)	100 (22.4)	100 (22.4)	100 (22.4)	100 (22.4)
Border Force	%	58	58	58	58
Force Constant	N/A (lbf/A)	40.8 (9.17)	25.8 (5.80)	40.8 (9.17)	25.8 (5.80)
Max. Current @ 72VDC	A	5.0	11.9	5.0	11.9
Max. Current @ 48VDC	A	3.3	8.0	3.3	8.0
Max. Velocity @ 72VDC	m/s (in/s)	1.6 (64)	2.6 (101)	1.6 (64)	2.6 (101)
Max. Velocity @ 48VDC	m/s (in/s)	1.1 (43)	1.7 (67)	1.1 (43)	1.7 (67)
Phase Resist. 25/80 °C	Ohm	11.7/14.2	4.9/5.9	11.7/14.2	4.9/5.9
Phase Inductance	mH	6.0	2.4	6.0	2.4
Thermal Resistance	°K/W	2.3	2.2	2.3	2.2
Thermal Time Const.	sec	3400	3200	3400	3200
Stator Diameter	mm (in)	37 (1.46)	37 (1.46)	37 (1.46)	37 (1.46)
Stator Length	mm (in)	336 (13.23)	336 (13.23)	347 (13.66)	347 (13.66)
Stator Mass	g (lb)	1385 (3.05)	1385 (3.05)	1385 (3.05)	1385 (3.05)
Slider Diameter	mm (in)	20 (0.79)	20 (0.79)	20 (0.79)	20 (0.79)
Slider Length	mm (in)	700 (27.56)	700 (27.56)	700 (27.56)	700 (27.56)
Slider Mass	g (lb)	1529 (3.37)	1529 (3.37)	1529 (3.37)	1529 (3.37)
Position Repeatability	mm (in)	±0.05 (±0.0020)	±0.05 (±0.0020)	±0.05 (±0.0020)	±0.05 (±0.0020)
Linearity	%	±0.15	±0.15	±0.15	±0.15
Repeatability with EPS	mm (in)	±0.01 (±0.0004)	±0.01 (±0.0004)	±0.01 (±0.0004)	±0.01 (±0.0004)
Linearity with EPS	mm (in)	±0.01 (±0.0004)	±0.01 (±0.0004)	±0.01 (±0.0004)	±0.01 (±0.0004)

Position-Time Diagram

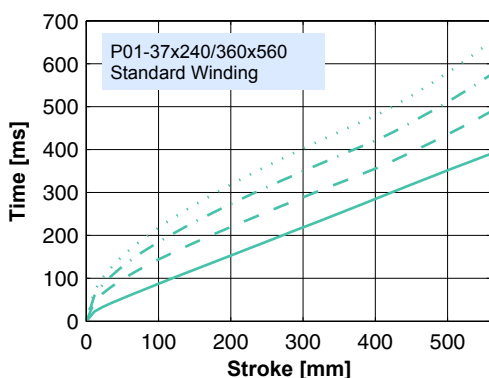

15.0 kg
 10.0 kg
 5.0 kg
 0.0 kg

Moving Slider

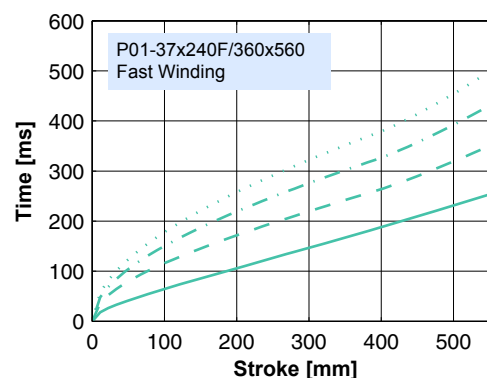

15.0 kg
 10.0 kg
 5.0 kg
 0.0 kg

Moving Slider

Connector Type

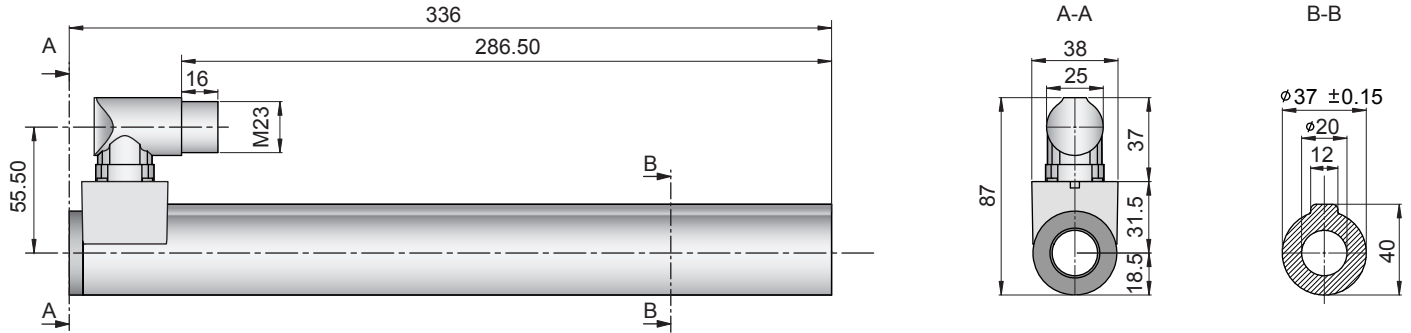

Linear Motor		Stator		Slider		
Type	Art.No	Type	Art. No.	Type	Art No.	
P01-37x240/360x560-C	-->	PS01-37x240-C	0150-1224	&	PL01-20x700/620	0150-1332
P01-37x240F/360x560-C	-->	PS01-37x240F-C	0150-1225	&	PL01-20x700/620	0150-1332

Cable Type

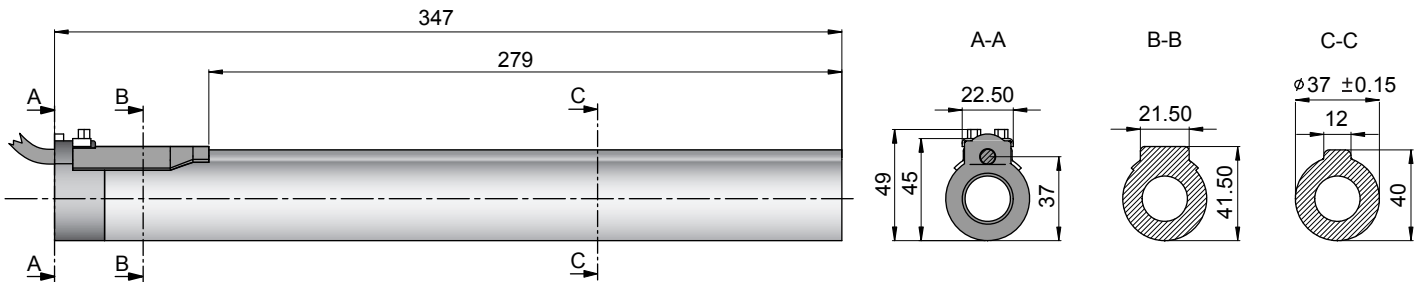

Linear Motor		Stator		Slider		
Type	Art.No	Type	Art. No.	Type	Art No.	
P01-37x240/360x560-P150	-->	PS01-37x240-P150	0150-1203	&	PL01-20x700/620	0150-1332
P01-37x240/360x560-C20	-->	PS01-37x240-C20	0150-1238	&	PL01-20x700/620	0150-1332
P01-37x240F/360x560-C20	-->	PS01-37x240F-C20	0150-1239	&	PL01-20x700/620	0150-1332

Slider

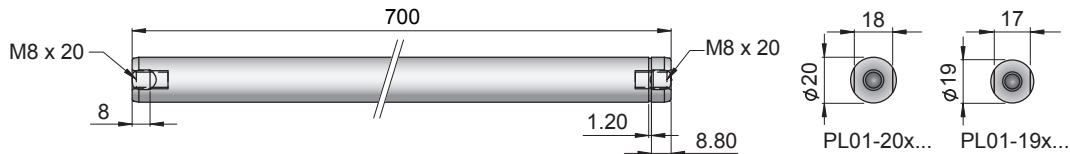

Standard Type	Slider Standard	PL01-20x700/620	0150-1332
Special Sliders	Heavy Duty Slider with WC/C-Coating	PL02-20x700/620	0150-1333
	Hollow Slider hole diameter 6.5mm	PL01-20x700/620-L	0150-1360
	High Clearance Slider d=19mm, m=1380g	PL01-19x700/620	0150-1457

Connectors

Motor Connector Wiring

Cable Length:
P01-37x240... 1.5m
P01-37x240...-C20 0.2m

		P01-37...-C P01-37...-C20	P01-37...
Ph 1+	red	A	1
Ph 1-	pink	B	2
Ph 2+	blue	C	3
Ph 2-	grey	D	4
+5VDC	white	E	5
GND	inner Shield	F	6
Sine	yellow	G	7
Cosine	green	H	8
Temp.	black	L	9
Shield	outer Shield	Case	10

Accessoires

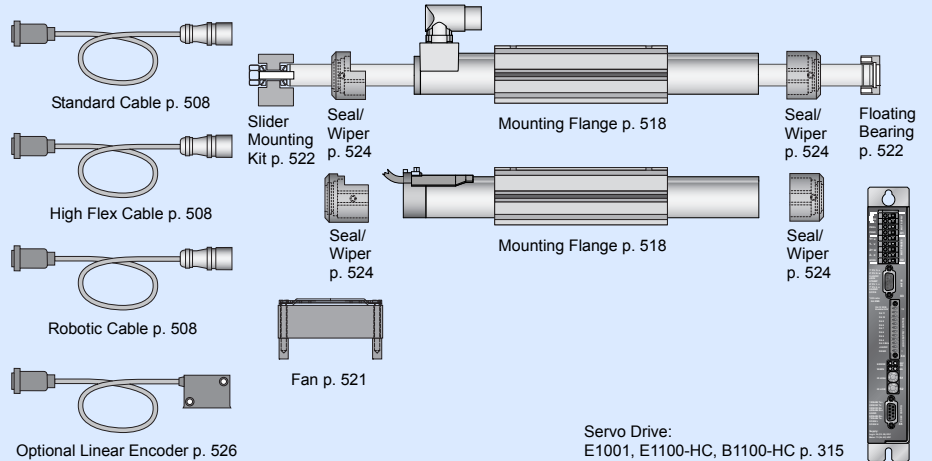

Servo Drive:
E1001, E1100-HC, B1100-HC p. 315

Max. Stroke: 660mm
Peak Force: 308N

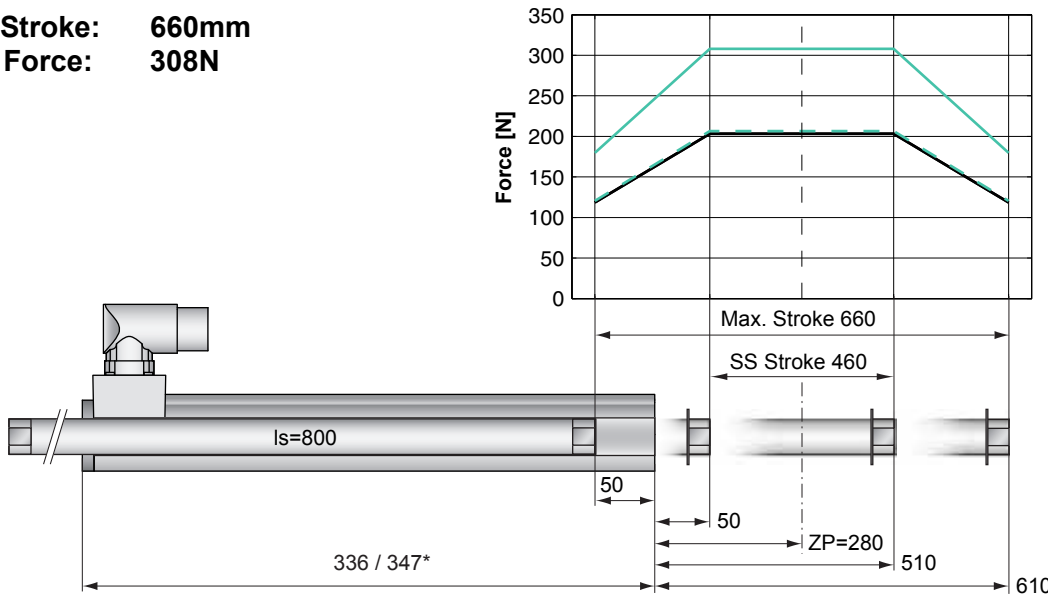

Standard Winding:
 — E1100-HC, 72VDC
 — E1100, 72VDC & E1001, 72VDC

Fast Winding:
 — E1100-HC, 72VDC
 - - E1100, 72VDC & E1001, 72VDC

Dimensions in mm
 *Cable Type

Motor Specification

	P01-	Connector Type		Cable Type	
		Standard Winding 37x240/460x660-C	Fast Winding 37x240F/460x660-C	Standard Winding 37x240/460x660-P150 37x240/460x660-C20	Fast Winding 37x240F/460x660-C20
Extended Stroke ES	mm (in)	660 (25.98)	660 (25.98)	660 (25.98)	660 (25.98)
Standard Stroke SS	mm (in)	460 (18.11)	460 (18.11)	460 (18.11)	460 (18.11)
Peak Force E1100-HC	N (lbf)	203 (45.7)	308 (69.2)	203 (45.7)	308 (69.2)
Peak Force E1100 / E1001	N (lbf)	203 (45.7)	206 (46.4)	203 (45.7)	206 (46.4)
Cont. Force	N (lbf)	53 (12.0)	53 (12.0)	53 (12.0)	53 (12.0)
Cont. Force Fan cooling	N (lbf)	100 (22.4)	100 (22.4)	100 (22.4)	100 (22.4)
Border Force	%	58	58	58	58
Force Constant	N/A (lbf/A)	40.8 (9.17)	25.8 (5.80)	40.8 (9.17)	25.8 (5.80)
Max. Current @ 72VDC	A	5.0	11.9	5.0	11.9
Max. Current @ 48VDC	A	3.3	8.0	3.3	8.0
Max. Velocity @ 72VDC	m/s (in/s)	1.6 (64)	2.6 (101)	1.6 (64)	2.6 (101)
Max. Velocity @ 48VDC	m/s (in/s)	1.1 (43)	1.7 (67)	1.1 (43)	1.7 (67)
Phase Resist. 25/80 °C	Ohm	11.7/14.2	4.9/5.9	11.7/14.2	4.9/5.9
Phase Inductance	mH	6.0	2.4	6.0	2.4
Thermal Resistance	°K/W	2.3	2.2	2.3	2.2
Thermal Time Const.	sec	3400	3200	3400	3200
Stator Diameter	mm (in)	37 (1.46)	37 (1.46)	37 (1.46)	37 (1.46)
Stator Length	mm (in)	336 (13.23)	336 (13.23)	347 (13.66)	347 (13.66)
Stator Mass	g (lb)	1385 (3.05)	1385 (3.05)	1385 (3.05)	1385 (3.05)
Slider Diameter	mm (in)	20 (0.79)	20 (0.79)	20 (0.79)	20 (0.79)
Slider Length	mm (in)	800 (31.50)	800 (31.50)	800 (31.50)	800 (31.50)
Slider Mass	g (lb)	1762 (3.88)	1762 (3.88)	1762 (3.88)	1762 (3.88)
Position Repeatability	mm (in)	±0.05 (±0.0020)	±0.05 (±0.0020)	±0.05 (±0.0020)	±0.05 (±0.0020)
Linearity	%	±0.15	±0.15	±0.15	±0.15
Repeatability with EPS	mm (in)	±0.01 (±0.0004)	±0.01 (±0.0004)	±0.01 (±0.0004)	±0.01 (±0.0004)
Linearity with EPS	mm (in)	±0.01 (±0.0004)	±0.01 (±0.0004)	±0.01 (±0.0004)	±0.01 (±0.0004)

Position-Time Diagram

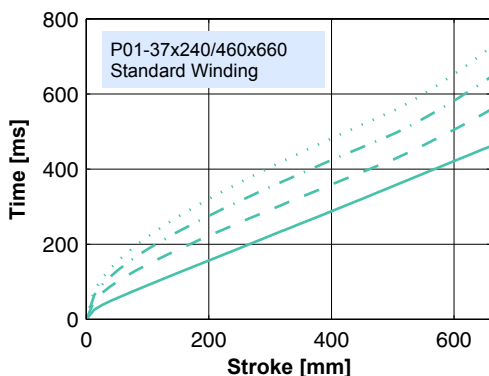

15.0 kg
 10.0 kg
 5.0 kg
 0.0 kg

Moving Slider

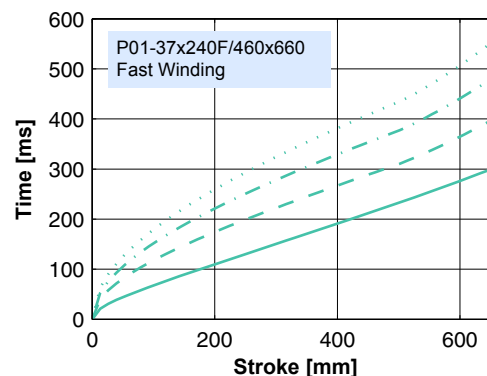

15.0 kg
 10.0 kg
 5.0 kg
 0.0 kg

Moving Slider

Connector Type

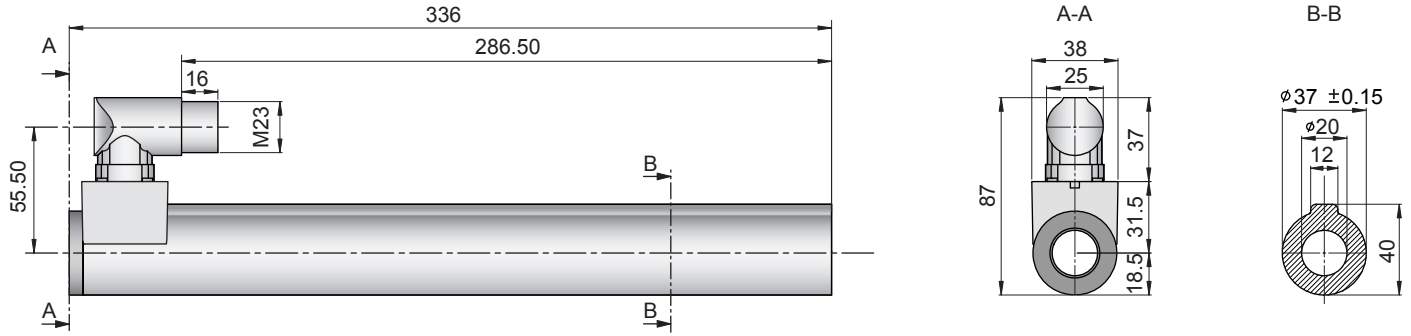

Linear Motor		Stator		Slider	
Type	Art.No	Type	Art. No.	Type	Art No.
P01-37x240/460x660-C	-->	PS01-37x240-C	0150-1224	&	PL01-20x800/720
P01-37x240F/460x660-C	-->	PS01-37x240F-C	0150-1225	&	PL01-20x800/720

Cable Type

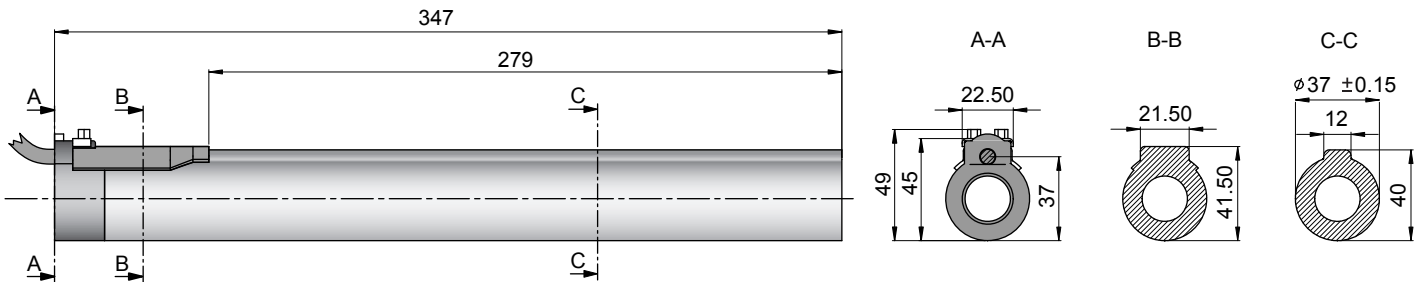

Linear Motor		Stator		Slider	
Type	Art.No	Type	Art. No.	Type	Art No.
P01-37x240/460x660-P150	-->	PS01-37x240-P150	0150-1203	&	PL01-20x800/720
P01-37x240/460x660-C20	-->	PS01-37x240-C20	0150-1238	&	PL01-20x800/720
P01-37x240F/460x660-C20	-->	PS01-37x240F-C20	0150-1239	&	PL01-20x800/720

Slider

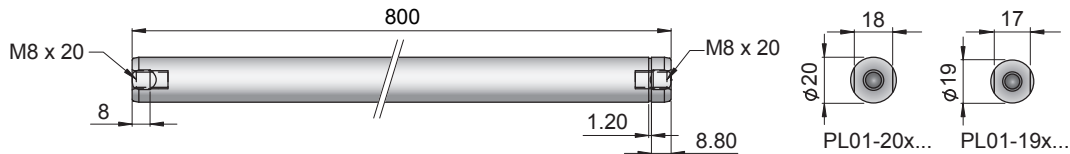

Standard Type	Slider Standard	PL01-20x800/720	0150-1334
Special Sliders	Heavy Duty Slider with WC/C-Coating	PL02-20x800/720	0150-1335
	Hollow Slider hole diameter 6.5mm	PL01-20x800/720-L	0150-1361

Connectors

Motor Connector Wiring		P01-37...-C P01-37...-C20	P01-37...
Cable Length:			
P01-37x240...	1.5m		
P01-37x240...-C20	0.2m		
Ph 1+	red	A	1
Ph 1-	pink	B	2
Ph 2+	blue	C	3
Ph 2-	grey	D	4
+5VDC	white	E	5
GND	inner Shield	F	6
Sine	yellow	G	7
Cosine	green	H	8
Temp.	black	L	9
Shield	outer Shield	Case	10

Accessoires

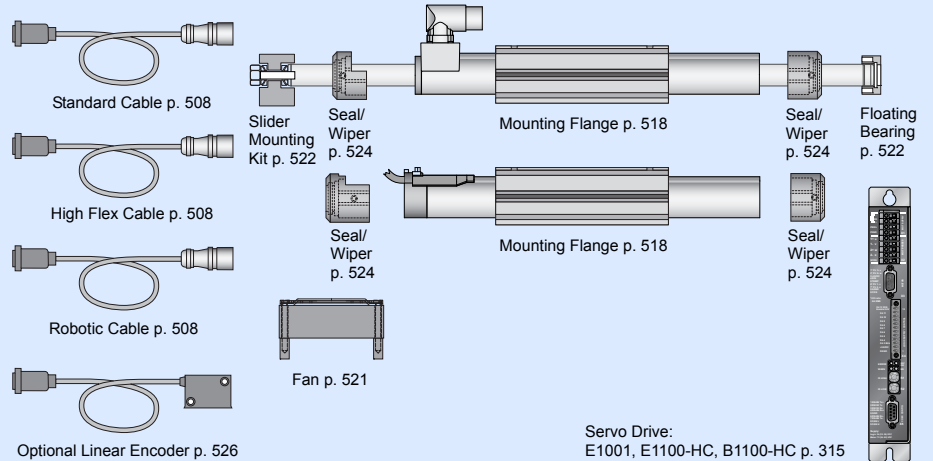

Servo Drive:
E1001, E1100-HC, B1100-HC p. 315

Max. Stroke: 760mm
Peak Force: 308N

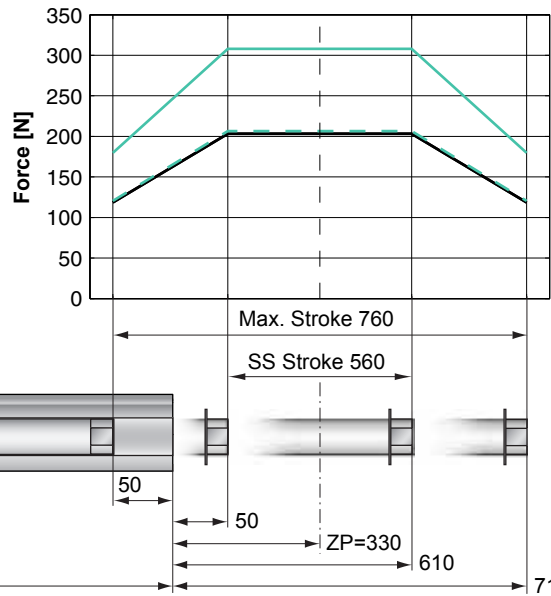

Standard Winding:
 — E1100-HC, 72VDC
 — E1100, 72VDC & E1001, 72VDC

Fast Winding:
 — E1100-HC, 72VDC
 - - E1100, 72VDC & E1001, 72VDC

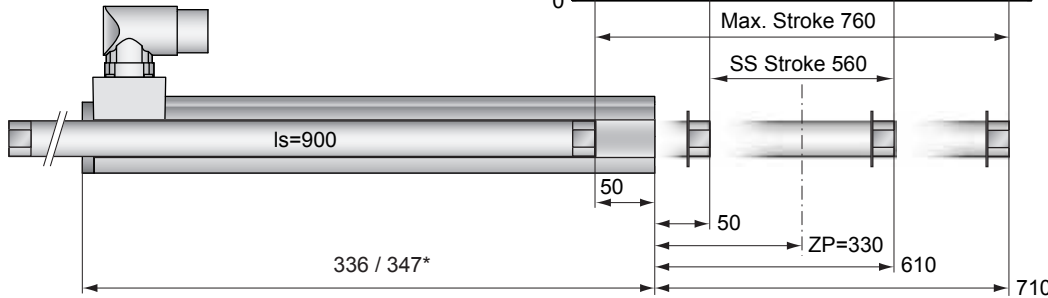

Dimensions in mm
 *Cable Type

Motor Specification

	P01-	Connector Type		Cable Type	
		Standard Winding 37x240/560x760-C	Fast Winding 37x240F/560x760-C	Standard Winding 37x240/560x760-P150 37x240/560x760-C20	Fast Winding 37x240F/560x760-C20
Extended Stroke ES	mm (in)	760 (29.92)	760 (29.92)	760 (29.92)	760 (29.92)
Standard Stroke SS	mm (in)	560 (22.05)	560 (22.05)	560 (22.05)	560 (22.05)
Peak Force E1100-HC	N (lbf)	203 (45.7)	308 (69.2)	203 (45.7)	308 (69.2)
Peak Force E1100 / E1001	N (lbf)	203 (45.7)	206 (46.4)	203 (45.7)	206 (46.4)
Cont. Force	N (lbf)	53 (12.0)	53 (12.0)	53 (12.0)	53 (12.0)
Cont. Force Fan cooling	N (lbf)	100 (22.4)	100 (22.4)	100 (22.4)	100 (22.4)
Border Force	%	58	58	58	58
Force Constant	N/A (lbf/A)	40.8 (9.17)	25.8 (5.80)	40.8 (9.17)	25.8 (5.80)
Max. Current @ 72VDC	A	5.0	11.9	5.0	11.9
Max. Current @ 48VDC	A	3.3	8.0	3.3	8.0
Max. Velocity @ 72VDC	m/s (in/s)	1.6 (64)	2.6 (101)	1.6 (64)	2.6 (101)
Max. Velocity @ 48VDC	m/s (in/s)	1.1 (43)	1.7 (67)	1.1 (43)	1.7 (67)
Phase Resist. 25/80 °C	Ohm	11.7/14.2	4.9/5.9	11.7/14.2	4.9/5.9
Phase Inductance	mH	6.0	2.4	6.0	2.4
Thermal Resistance	°K/W	2.3	2.2	2.3	2.2
Thermal Time Const.	sec	3400	3200	3400	3200
Stator Diameter	mm (in)	37 (1.46)	37 (1.46)	37 (1.46)	37 (1.46)
Stator Length	mm (in)	336 (13.23)	336 (13.23)	347 (13.66)	347 (13.66)
Stator Mass	g (lb)	1385 (3.05)	1385 (3.05)	1385 (3.05)	1385 (3.05)
Slider Diameter	mm (in)	20 (0.79)	20 (0.79)	20 (0.79)	20 (0.79)
Slider Length	mm (in)	900 (35.43)	900 (35.43)	900 (35.43)	900 (35.43)
Slider Mass	g (lb)	1994 (4.40)	1994 (4.40)	1994 (4.40)	1994 (4.40)
Position Repeatability	mm (in)	±0.05 (±0.0020)	±0.05 (±0.0020)	±0.05 (±0.0020)	±0.05 (±0.0020)
Linearity	%	±0.15	±0.15	±0.15	±0.15
Repeatability with EPS	mm (in)	±0.01 (±0.0004)	±0.01 (±0.0004)	±0.01 (±0.0004)	±0.01 (±0.0004)
Linearity with EPS	mm (in)	±0.01 (±0.0004)	±0.01 (±0.0004)	±0.01 (±0.0004)	±0.01 (±0.0004)

Position-Time Diagram

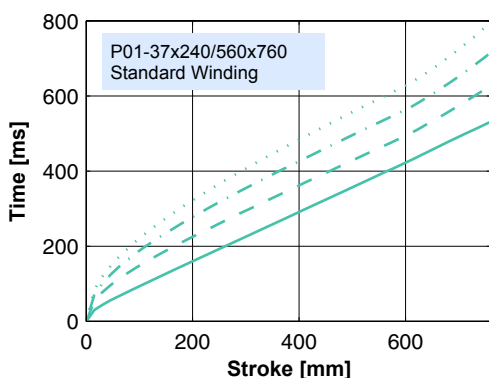

15.0 kg
 10.0 kg
 5.0 kg
 0.0 kg

Moving Slider

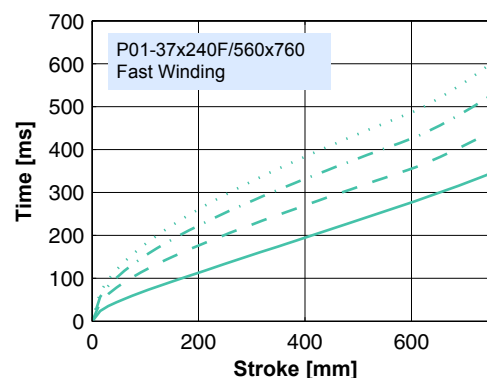

15.0 kg
 10.0 kg
 5.0 kg
 0.0 kg

Moving Slider

Connector Type

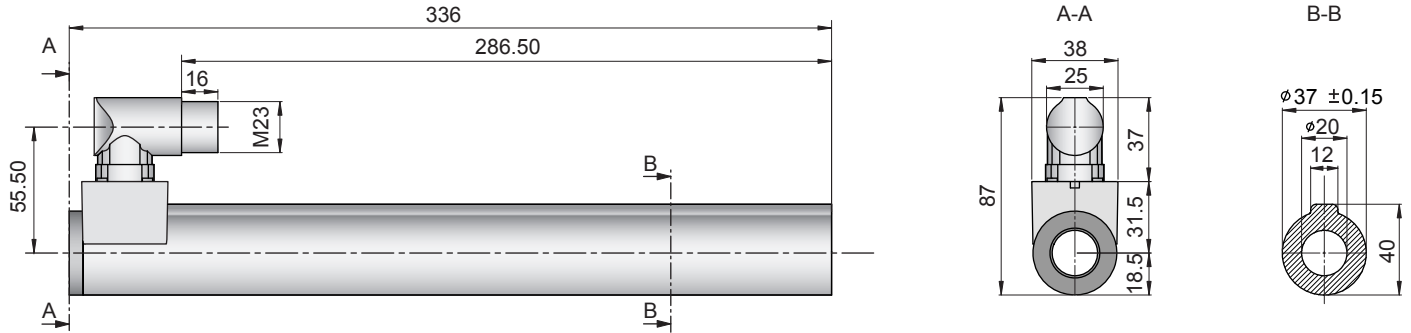

Linear Motor		Stator		Slider	
Type	Art.No	Type	Art. No.	Type	Art No.
P01-37x240/560x760-C	-->	PS01-37x240-C	0150-1224	& PL01-20x900/820	0150-1336
P01-37x240F/560x760-C	-->	PS01-37x240F-C	0150-1225	& PL01-20x900/820	0150-1336

Cable Type

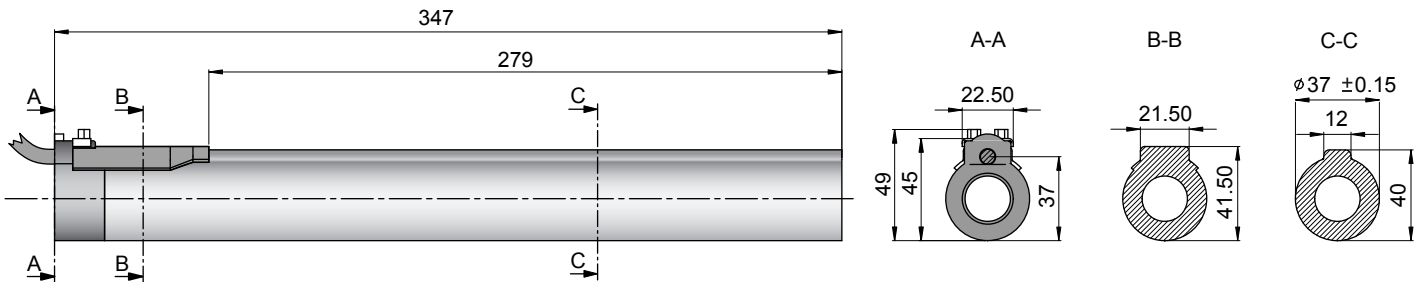

Linear Motor		Stator		Slider	
Type	Art.No	Type	Art. No.	Type	Art No.
P01-37x240/560x760-P150	-->	PS01-37x240-P150	0150-1203	& PL01-20x900/820	0150-1336
P01-37x240/560x760-C20	-->	PS01-37x240-C20	0150-1238	& PL01-20x900/820	0150-1336
P01-37x240F/560x760-C20	-->	PS01-37x240F-C20	0150-1239	& PL01-20x900/820	0150-1336

Slider

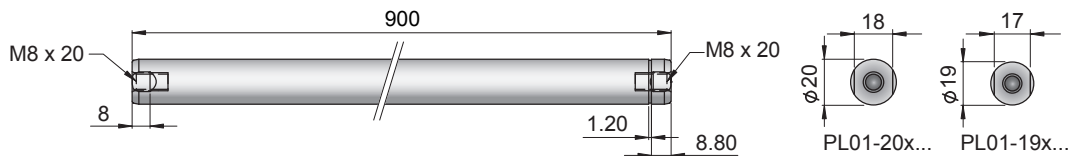

Standard Type	Slider Standard	PL01-20x900/820	0150-1336
Special Sliders	Heavy Duty Slider with WC/C-Coating	PL02-20x900/820	0150-1337
	Hollow Slider hole diameter 6.5mm	PL01-20x900/820-L	0150-1362

Connectors

Motor Connector Wiring

Cable Length:
P01-37x240... 1.5m
P01-37x240...-C20 0.2m

Wire Color	Pin	Case	Order
Ph 1+	red	A	1
Ph 1-	pink	B	2
Ph 2+	blue	C	3
Ph 2-	grey	D	4
+5VDC	white	E	5
GND	inner Shield	F	6
Sine	yellow	G	7
Cosine	green	H	8
Temp.	black	L	9
Shield	outer Shield	Case	10

Accessoires

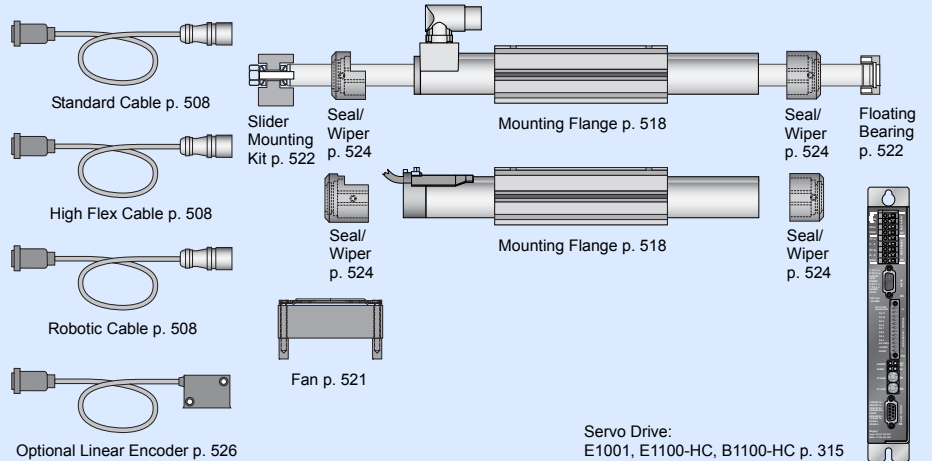

Servo Drive:
E1001, E1100-HC, B1100-HC p. 315

Max. Stroke: 860mm
Peak Force: 308N

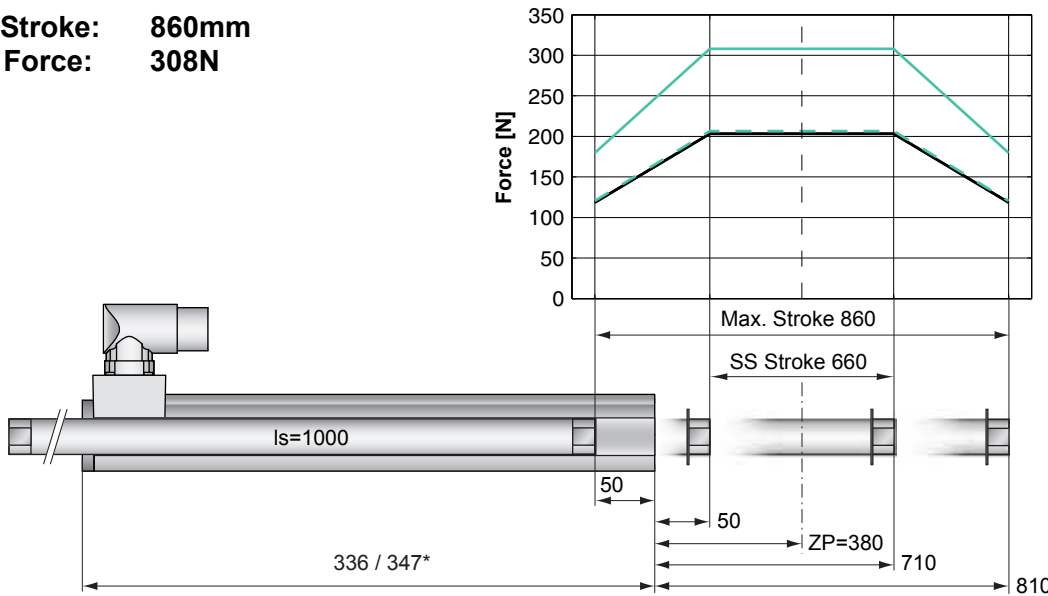

Standard Winding:
 — E1100-HC, 72VDC
 — E1100, 72VDC & E1001, 72VDC

Fast Winding:
 — E1100-HC, 72VDC
 - - E1100, 72VDC & E1001, 72VDC

Dimensions in mm
 *Cable Type

Motor Specification

	Connector Type	Cable Type	
		Standard Winding	Fast Winding
		37x240/660x860-C	37x240F/660x860-C
		37x240/660x860-P150	37x240/660x860-C20
		37x240F/660x860-C20	
Extended Stroke ES	mm (in)	860 (33.86)	860 (33.86)
Standard Stroke SS	mm (in)	660 (25.98)	660 (25.98)
Peak Force E1100-HC	N (lbf)	203 (45.7)	308 (69.2)
Peak Force E1100 / E1001	N (lbf)	203 (45.7)	206 (46.4)
Cont. Force	N (lbf)	53 (12.0)	53 (12.0)
Cont. Force Fan cooling	N (lbf)	100 (22.4)	100 (22.4)
Border Force	%	58	58
Force Constant	N/A (lbf/A)	40.8 (9.17)	25.8 (5.80)
Max. Current @ 72VDC	A	5.0	11.9
Max. Current @ 48VDC	A	3.3	8.0
Max. Velocity @ 72VDC	m/s (in/s)	1.6 (64)	2.6 (101)
Max. Velocity @ 48VDC	m/s (in/s)	1.1 (43)	1.7 (67)
Phase Resist. 25/80 °C	Ohm	11.7/14.2	4.9/5.9
Phase Inductance	mH	6.0	2.4
Thermal Resistance	°K/W	2.3	2.2
Thermal Time Const.	sec	3400	3200
Stator Diameter	mm (in)	37 (1.46)	37 (1.46)
Stator Length	mm (in)	336 (13.23)	336 (13.23)
Stator Mass	g (lb)	1385 (3.05)	1385 (3.05)
Slider Diameter	mm (in)	20 (0.79)	20 (0.79)
Slider Length	mm (in)	1000 (39.37)	1000 (39.37)
Slider Mass	g (lb)	2227 (4.91)	2227 (4.91)
Position Repeatability	mm (in)	±0.05 (±0.0020)	±0.05 (±0.0020)
Linearity	%	±0.15	±0.15
Repeatability with EPS	mm (in)	±0.01 (±0.0004)	±0.01 (±0.0004)
Linearity with EPS	mm (in)	±0.01 (±0.0004)	±0.01 (±0.0004)

Position-Time Diagram

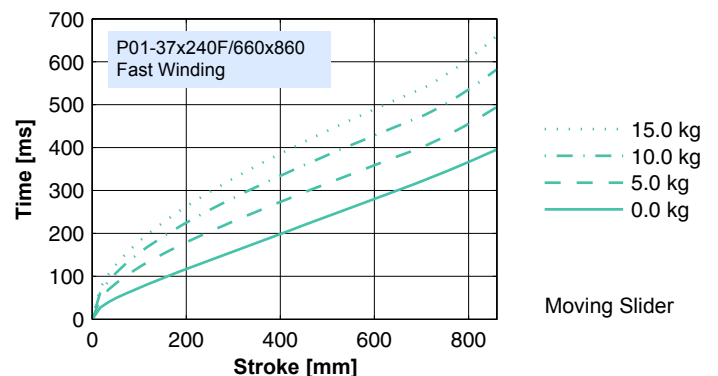
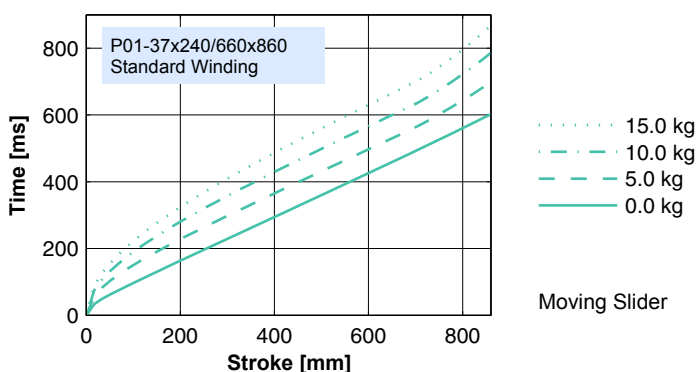

Connector Type

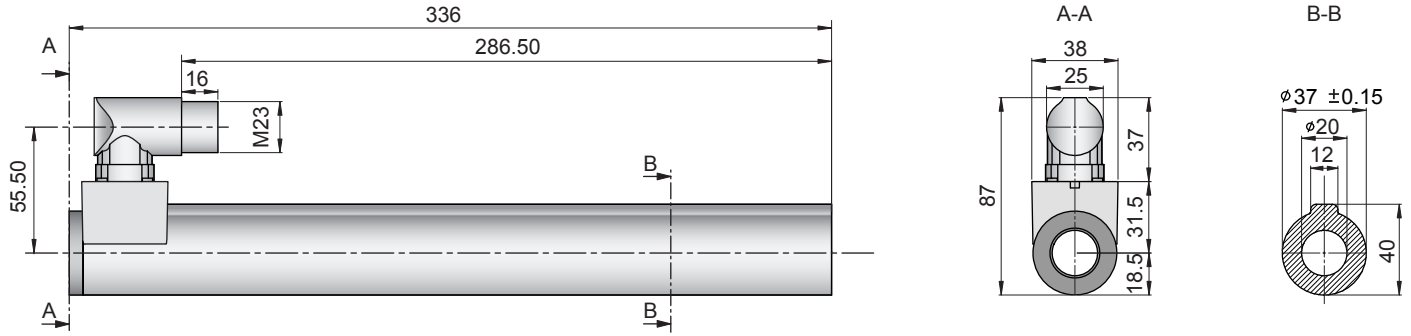

Linear Motor		Stator		Slider	
Type	Art.No	Type	Art. No.	Type	Art No.
P01-37x240/660x860-C	-->	PS01-37x240-C	0150-1224	& PL01-20x1000/920	0150-1338
P01-37x240F/660x860-C	-->	PS01-37x240F-C	0150-1225	& PL01-20x1000/920	0150-1338

Cable Type

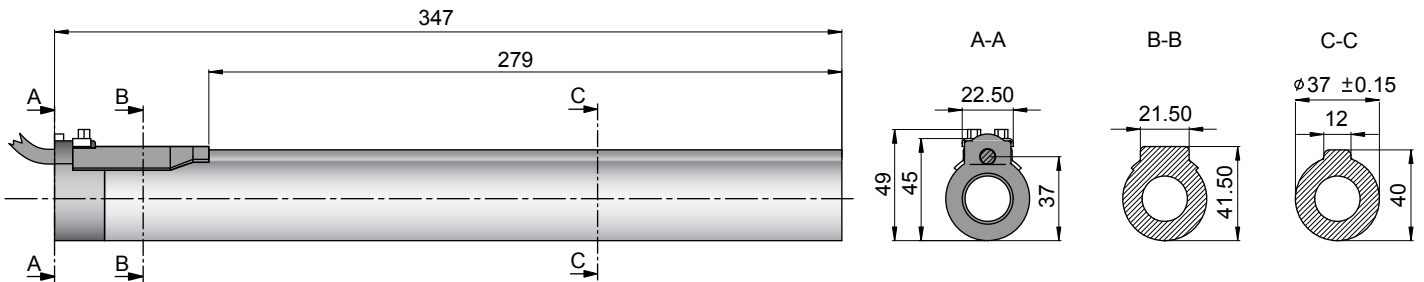

Linear Motor		Stator		Slider	
Type	Art.No	Type	Art. No.	Type	Art No.
P01-37x240/660x860-P150	-->	PS01-37x240-P150	0150-1203	& PL01-20x1000/920	0150-1338
P01-37x240/660x860-C20	-->	PS01-37x240-C20	0150-1238	& PL01-20x1000/920	0150-1338
P01-37x240F/660x860-C20	-->	PS01-37x240F-C20	0150-1239	& PL01-20x1000/920	0150-1338

Slider

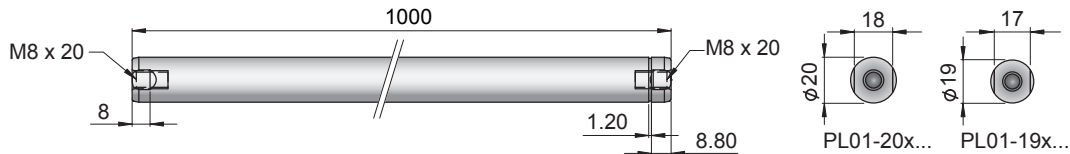

Standard Type	Slider Standard	PL01-20x1000/920	0150-1338
Special Sliders	Heavy Duty Slider with WC/C-Coating	PL02-20x1000/920	on request
	Hollow Slider hole diameter 6.5mm	PL01-20x1000/920-L	0150-1364

Connectors

Motor Connector Wiring

Cable Length:
P01-37x240... 1.5m
P01-37x240...-C20 0.2m

		P01-37...-C P01-37...-C20	P01-37...
Ph 1+	red	A	1
Ph 1-	pink	B	2
Ph 2+	blue	C	3
Ph 2-	grey	D	4
+5VDC	white	E	5
GND	inner Shield	F	6
Sine	yellow	G	7
Cosine	green	H	8
Temp.	black	L	9
Shield	outer Shield	Case	10

Accessoires

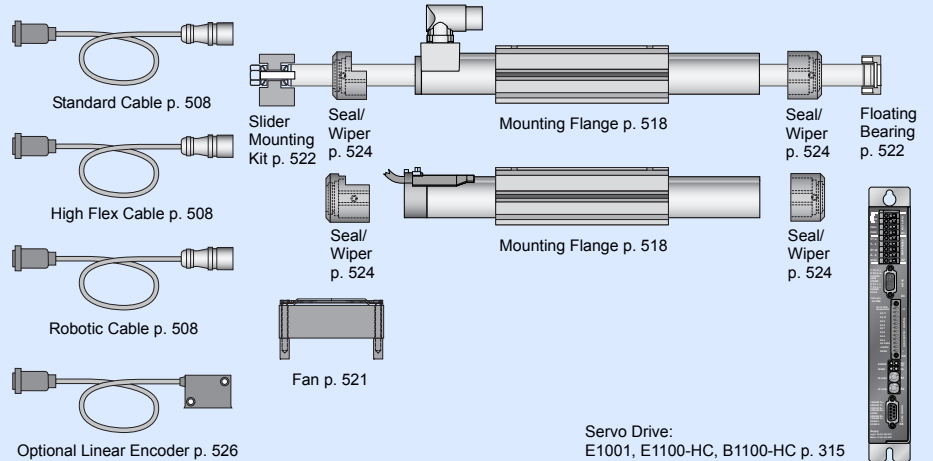

Servo Drive:
E1001, E1100-HC, B1100-HC p. 315

Max. Stroke: 1060mm
Peak Force: 308N

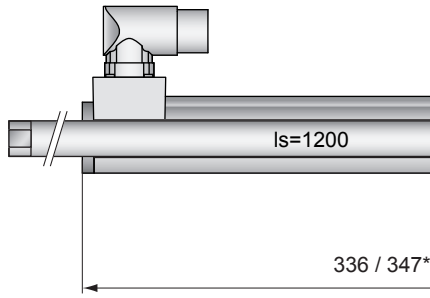
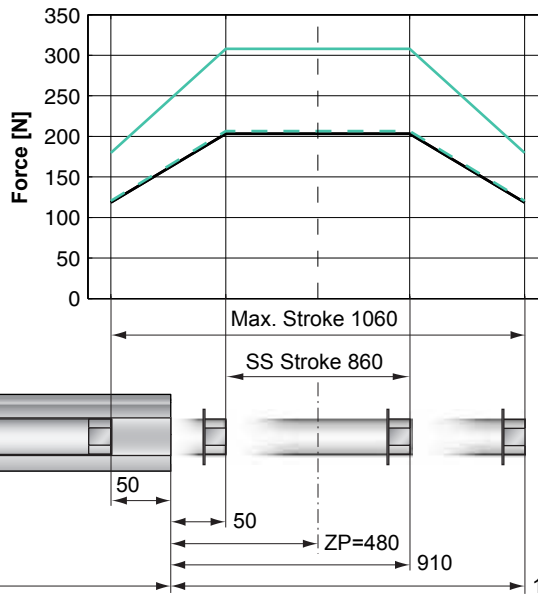

Dimensions in mm
 *Cable Type

Motor Specification

	P01-	Connector Type		Cable Type	
		Standard Winding 37x240/860x1060-C	Fast Winding 37x240F/860x1060-C	Standard Winding 37x240/860x1060-P150 37x240/860x1060-C20	Fast Winding 37x240F/860x1060-C20
Extended Stroke ES	mm (in)	1060 (41.73)	1060 (41.73)	1060 (41.73)	1060 (41.73)
Standard Stroke SS	mm (in)	860 (33.86)	860 (33.86)	860 (33.86)	860 (33.86)
Peak Force E1100-HC	N (lbf)	203 (45.7)	308 (69.2)	203 (45.7)	308 (69.2)
Peak Force E1100 / E1001	N (lbf)	203 (45.7)	206 (46.4)	203 (45.7)	206 (46.4)
Cont. Force	N (lbf)	53 (12.0)	53 (12.0)	53 (12.0)	53 (12.0)
Cont. Force Fan cooling	N (lbf)	100 (22.4)	100 (22.4)	100 (22.4)	100 (22.4)
Border Force	%	58	58	58	58
Force Constant	N/A (lbf/A)	40.8 (9.17)	25.8 (5.80)	40.8 (9.17)	25.8 (5.80)
Max. Current @ 72VDC	A	5.0	11.9	5.0	11.9
Max. Current @ 48VDC	A	3.3	8.0	3.3	8.0
Max. Velocity @ 72VDC	m/s (in/s)	1.6 (64)	2.6 (101)	1.6 (64)	2.6 (101)
Max. Velocity @ 48VDC	m/s (in/s)	1.1 (43)	1.7 (67)	1.1 (43)	1.7 (67)
Phase Resist. 25/80 °C	Ohm	11.7/14.2	4.9/5.9	11.7/14.2	4.9/5.9
Phase Inductance	mH	6.0	2.4	6.0	2.4
Thermal Resistance	°K/W	2.3	2.2	2.3	2.2
Thermal Time Const.	sec	3400	3200	3400	3200
Stator Diameter	mm (in)	37 (1.46)	37 (1.46)	37 (1.46)	37 (1.46)
Stator Length	mm (in)	336 (13.23)	336 (13.23)	347 (13.66)	347 (13.66)
Stator Mass	g (lb)	1385 (3.05)	1385 (3.05)	1385 (3.05)	1385 (3.05)
Slider Diameter	mm (in)	20 (0.79)	20 (0.79)	20 (0.79)	20 (0.79)
Slider Length	mm (in)	1200 (47.24)	1200 (47.24)	1200 (47.24)	1200 (47.24)
Slider Mass	g (lb)	2692 (5.93)	2692 (5.93)	2692 (5.93)	2692 (5.93)
Position Repeatability	mm (in)	±0.05 (±0.0020)	±0.05 (±0.0020)	±0.05 (±0.0020)	±0.05 (±0.0020)
Linearity	%	±0.10	±0.10	±0.10	±0.10
Repeatability with EPS	mm (in)	±0.01 (±0.0004)	±0.01 (±0.0004)	±0.01 (±0.0004)	±0.01 (±0.0004)
Linearity with EPS	mm (in)	±0.01 (±0.0004)	±0.01 (±0.0004)	±0.01 (±0.0004)	±0.01 (±0.0004)

Position-Time Diagram

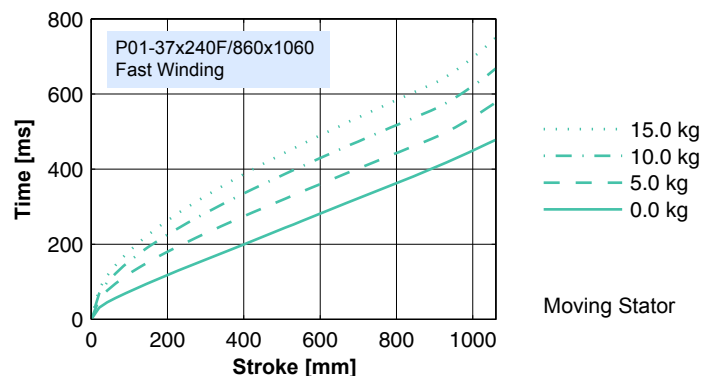
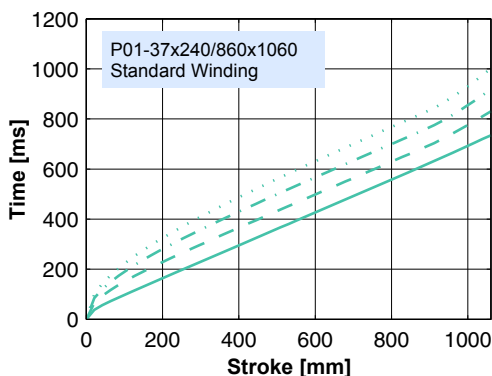

Connector Type

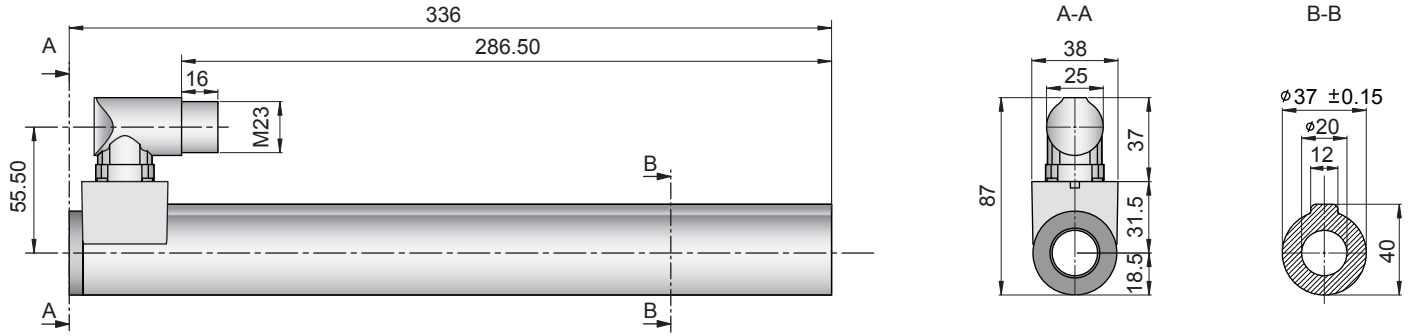

Linear Motor		Stator		Slider		
Type	Art.No	Type	Art. No.	Type	Art No.	
P01-37x240/860x1060-C	-->	PS01-37x240-C	0150-1224	&	PL01-20x1200/1120	0150-1340
P01-37x240F/860x1060-C	-->	PS01-37x240F-C	0150-1225	&	PL01-20x1200/1120	0150-1340

Cable Type

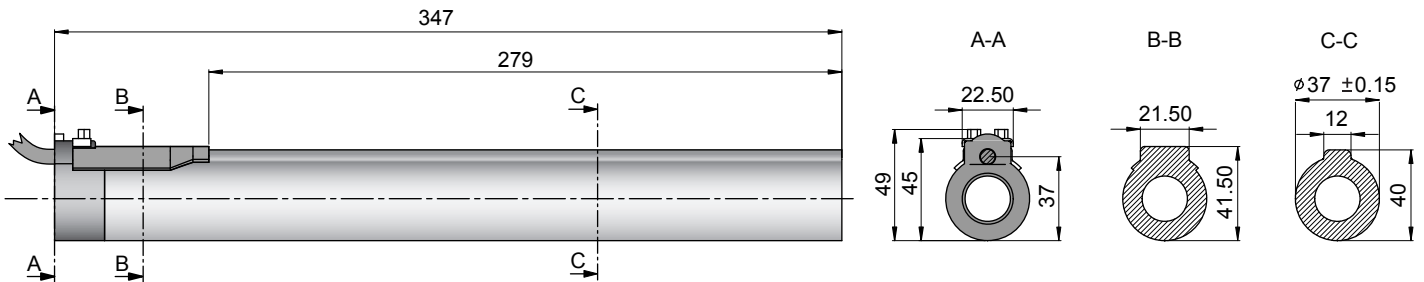

Linear Motor		Stator		Slider		
Type	Art.No	Type	Art. No.	Type	Art No.	
P01-37x240/860x1060-P150	-->	PS01-37x240-P150	0150-1203	&	PL01-20x1200/1120	0150-1340
P01-37x240/860x1060-C20	-->	PS01-37x240-C20	0150-1238	&	PL01-20x1200/1120	0150-1340
P01-37x240F/860x1060-C20	-->	PS01-37x240F-C20	0150-1239	&	PL01-20x1200/1120	0150-1340

Slider

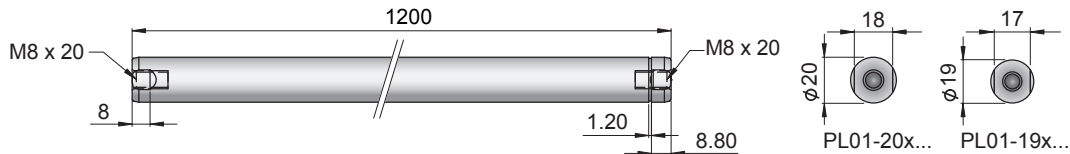

Standard Type	Slider Standard	PL01-20x1200/1120	0150-1340
Special Sliders	Heavy Duty Slider with WC/C-Coating	PL02-20x1200/1120	on request
	Hollow Slider hole diameter 6.5mm	PL01-20x1200/1120-L	0150-1376

Connectors

Motor Connector Wiring		Cable Length:		P01-37...-C		P01-37...-C20		P01-37...-C20	
Ph 1+	red	A	1	1.5m					
Ph 1-	pink	B	2	0.2m					
Ph 2+	blue	C	3						
Ph 2-	grey	D	4						
+5VDC	white	E	5						
GND	inner Shield	F	6						
Sine	yellow	G	7						
Cosine	green	H	8						
Temp.	black	L	9						
Shield	outer Shield	Case	10						

Accessoires

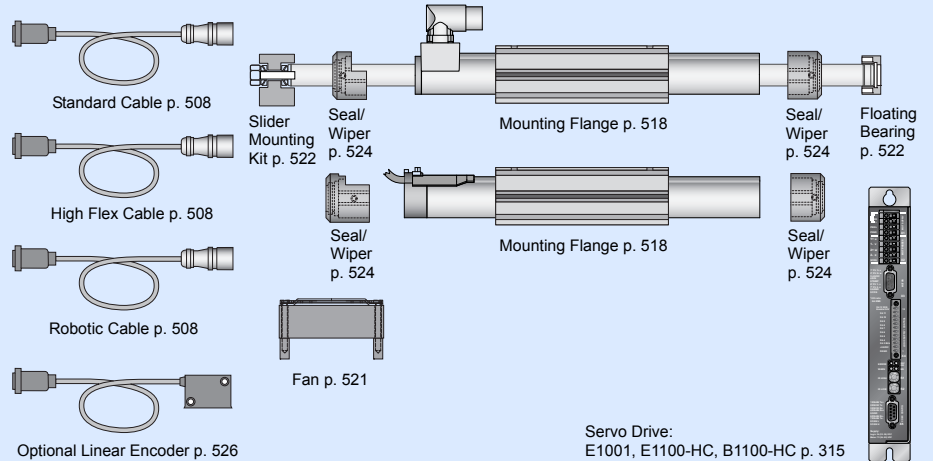

Servo Drive:
E1001, E1100-HC, B1100-HC p. 315

Max. Stroke: 1260mm
Peak Force: 308N

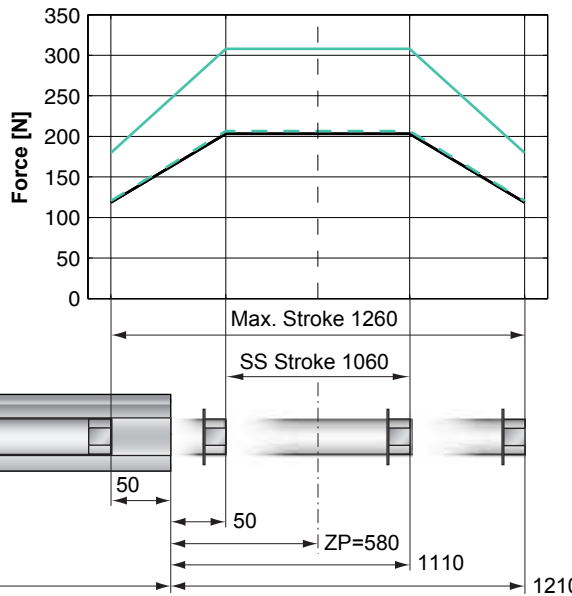

Standard Winding:
 — E1100-HC, 72VDC
 — E1100, 72VDC & E1001, 72VDC

Fast Winding:
 — E1100-HC, 72VDC
 - - E1100, 72VDC & E1001, 72VDC

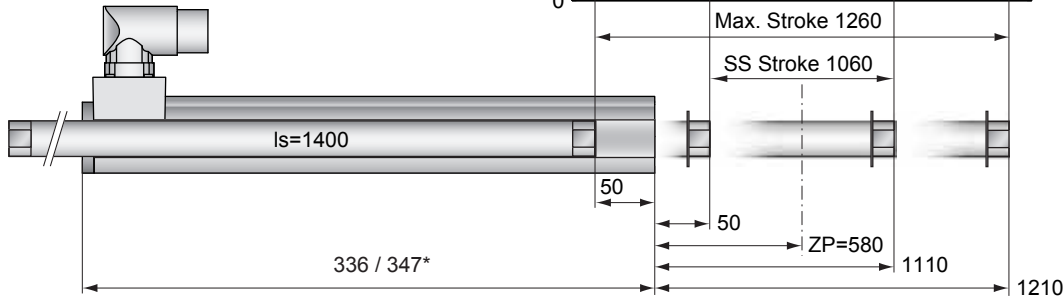

Dimensions in mm
 *Cable Type

Motor Specification

	Connector Type	Cable Type	
		Standard Winding	Fast Winding
		P01-37x240/1060x1260-C	37x240F/1060x1260-C
		37x240/1060x1260-P150	37x240/1060x1260-C20
		37x240F/1060x1260-C20	
Extended Stroke ES	mm (in)	1260 (49.61)	1260 (49.61)
Standard Stroke SS	mm (in)	1060 (41.73)	1060 (41.73)
Peak Force E1100-HC	N (lbf)	203 (45.7)	308 (69.2)
Peak Force E1100 / E1001	N (lbf)	203 (45.7)	206 (46.4)
Cont. Force	N (lbf)	53 (12.0)	53 (12.0)
Cont. Force Fan cooling	N (lbf)	100 (22.4)	100 (22.4)
Border Force	%	58	58
Force Constant	N/A (lbf/A)	40.8 (9.17)	25.8 (5.80)
Max. Current @ 72VDC	A	5.0	11.9
Max. Current @ 48VDC	A	3.3	8.0
Max. Velocity @ 72VDC	m/s (in/s)	1.6 (64)	2.6 (101)
Max. Velocity @ 48VDC	m/s (in/s)	1.1 (43)	1.7 (67)
Phase Resist. 25/80 °C	Ohm	11.7/14.2	4.9/5.9
Phase Inductance	mH	6.0	2.4
Thermal Resistance	°K/W	2.3	2.2
Thermal Time Const.	sec	3400	3200
Stator Diameter	mm (in)	37 (1.46)	37 (1.46)
Stator Length	mm (in)	336 (13.23)	336 (13.23)
Stator Mass	g (lb)	1385 (3.05)	1385 (3.05)
Slider Diameter	mm (in)	20 (0.79)	20 (0.79)
Slider Length	mm (in)	1400 (55.12)	1400 (55.12)
Slider Mass	g (lb)	3157 (6.96)	3157 (6.96)
Position Repeatability	mm (in)	±0.05 (±0.0020)	±0.05 (±0.0020)
Linearity	%	±0.10	±0.10
Repeatability with EPS	mm (in)	±0.01 (±0.0004)	±0.01 (±0.0004)
Linearity with EPS	mm (in)	±0.01 (±0.0004)	±0.01 (±0.0004)

Position-Time Diagram

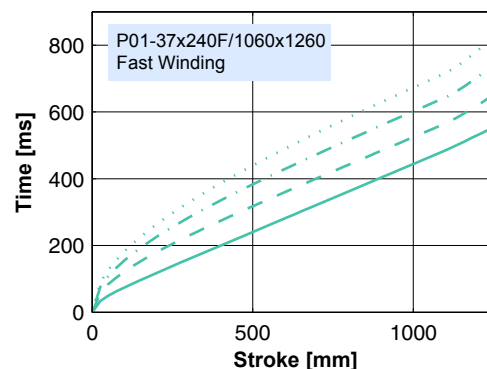
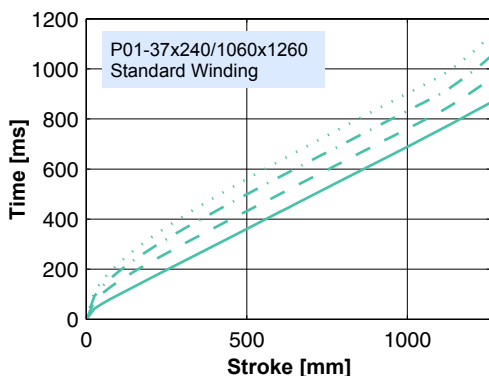

Connector Type

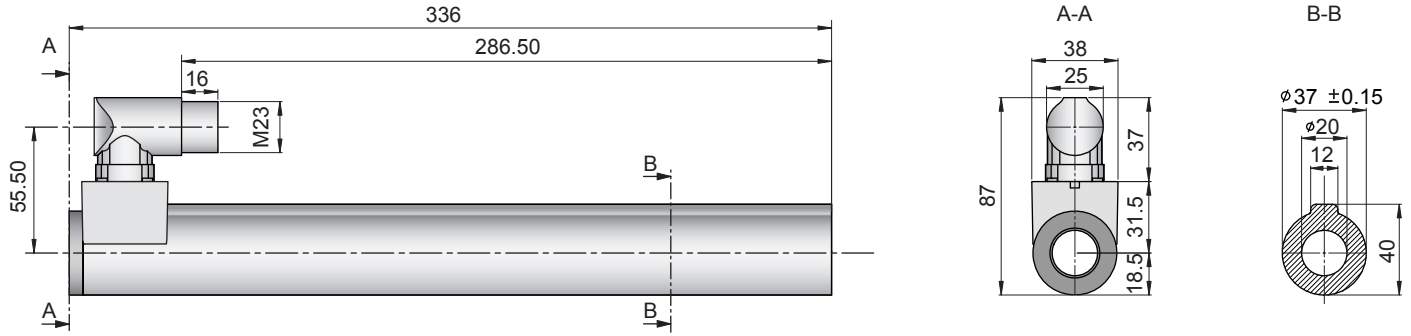

Linear Motor		Stator		Slider		
Type	Art.No	Type	Art. No.	Type	Art No.	
P01-37x240/1060x1260-C	-->	PS01-37x240-C	0150-1224	&	PL01-20x1400/1320	0150-1342
P01-37x240F/1060x1260-C	-->	PS01-37x240F-C	0150-1225	&	PL01-20x1400/1320	0150-1342

Cable Type

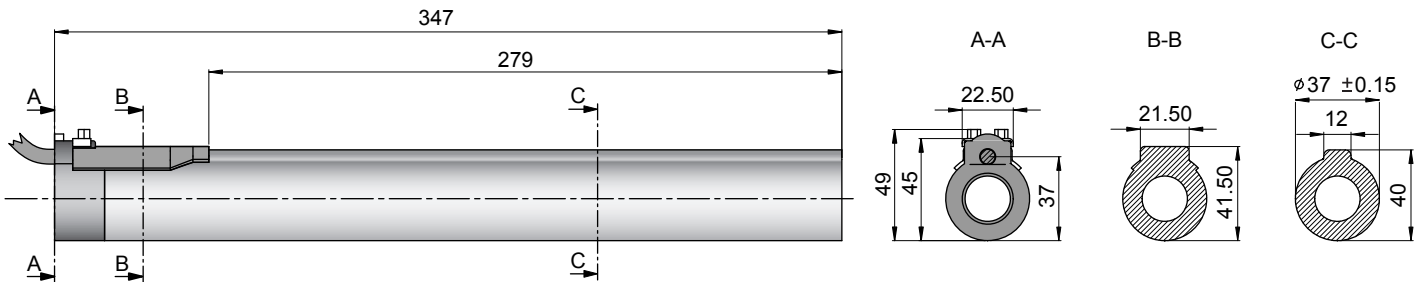

Linear Motor		Stator		Slider		
Type	Art.No	Type	Art. No.	Type	Art No.	
P01-37x240/1060x1260-P150	-->	PS01-37x240-P150	0150-1203	&	PL01-20x1400/1320	0150-1342
P01-37x240/1060x1260-C20	-->	PS01-37x240-C20	0150-1238	&	PL01-20x1400/1320	0150-1342
P01-37x240F/1060x1260-C20	-->	PS01-37x240F-C20	0150-1239	&	PL01-20x1400/1320	0150-1342

Slider

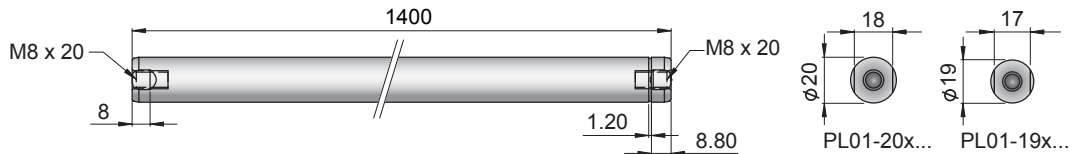

Standard Type	Slider Standard	PL01-20x1400/1320	0150-1342
Special Sliders	Heavy Duty Slider with WC/C-Coating	PL02-20x1400/1320	on request
	Hollow Slider hole diameter 6.5mm	PL01-20x1400/1320-L	on request

Connectors

Motor Connector Wiring		P01-37...-C P01-37...-C20	P01-37...
Cable Length:			
P01-37x240...	1.5m		
P01-37x240...-C20	0.2m		
Ph 1+	red	A	1
Ph 1-	pink	B	2
Ph 2+	blue	C	3
Ph 2-	grey	D	4
+5VDC	white	E	5
GND	inner Shield	F	6
Sine	yellow	G	7
Cosine	green	H	8
Temp.	black	L	9
Shield	outer Shield	Case	10

Accessoires

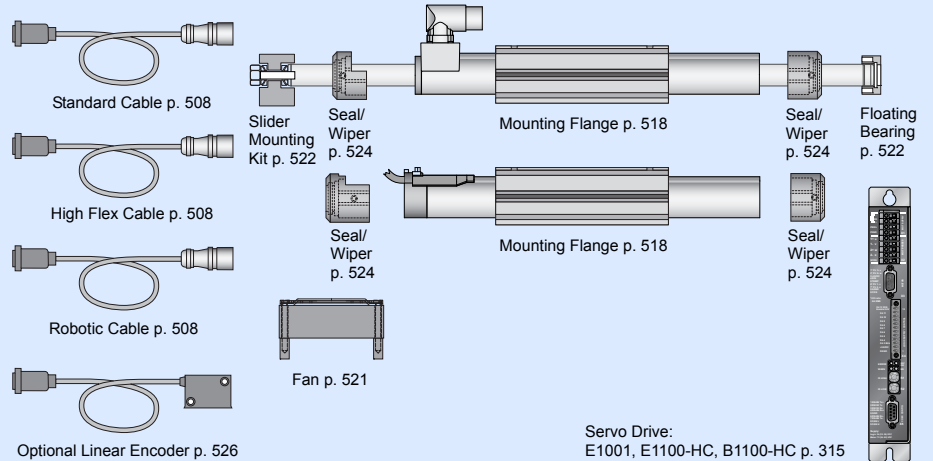

Servo Drive:
E1001, E1100-HC, B1100-HC p. 315

Max. Stroke: 1460mm
Peak Force: 308N

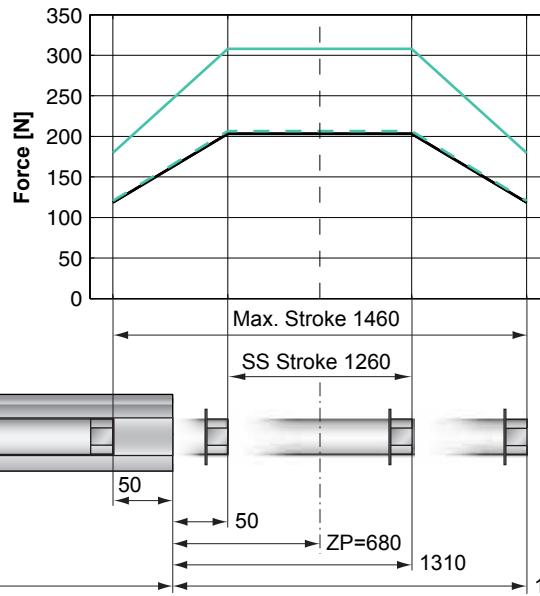

Standard Winding:
 — E1100-HC, 72VDC
 — E1100, 72VDC & E1001, 72VDC

Fast Winding:
 — E1100-HC, 72VDC
 - - E1100, 72VDC & E1001, 72VDC

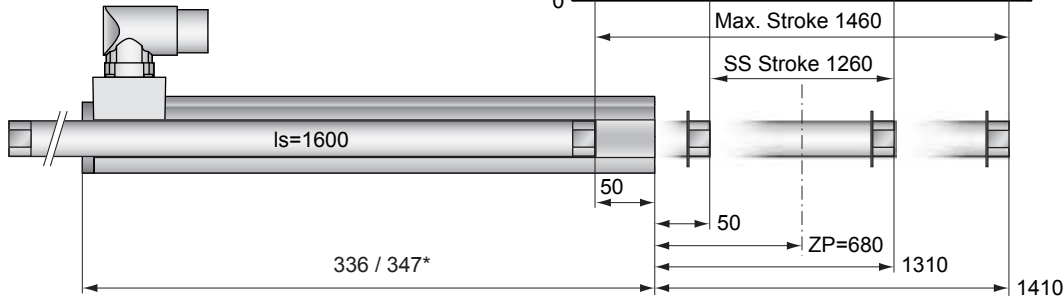

Dimensions in mm
 *Cable Type

Motor Specification

	P01-	Connector Type		Cable Type	
		Standard Winding 37x240/1260x1460-C	Fast Winding 37x240F/1260x1460-C	Standard Winding 37x240/1260x1460-P150 37x240/1260x1460-C20	Fast Winding 37x240F/1260x1460-C20
Extended Stroke ES	mm (in)	1460 (57.48)	1460 (57.48)	1460 (57.48)	1460 (57.48)
Standard Stroke SS	mm (in)	1260 (49.61)	1260 (49.61)	1260 (49.61)	1260 (49.61)
Peak Force E1100-HC	N (lbf)	203 (45.7)	308 (69.2)	203 (45.7)	308 (69.2)
Peak Force E1100 / E1001	N (lbf)	203 (45.7)	206 (46.4)	203 (45.7)	206 (46.4)
Cont. Force	N (lbf)	53 (12.0)	53 (12.0)	53 (12.0)	53 (12.0)
Cont. Force Fan cooling	N (lbf)	100 (22.4)	100 (22.4)	100 (22.4)	100 (22.4)
Border Force	%	58	58	58	58
Force Constant	N/A (lbf/A)	40.8 (9.17)	25.8 (5.80)	40.8 (9.17)	25.8 (5.80)
Max. Current @ 72VDC	A	5.0	11.9	5.0	11.9
Max. Current @ 48VDC	A	3.3	8.0	3.3	8.0
Max. Velocity @ 72VDC	m/s (in/s)	1.6 (64)	2.6 (101)	1.6 (64)	2.6 (101)
Max. Velocity @ 48VDC	m/s (in/s)	1.1 (43)	1.7 (67)	1.1 (43)	1.7 (67)
Phase Resist. 25/80 °C	Ohm	11.7/14.2	4.9/5.9	11.7/14.2	4.9/5.9
Phase Inductance	mH	6.0	2.4	6.0	2.4
Thermal Resistance	°K/W	2.3	2.2	2.3	2.2
Thermal Time Const.	sec	3400	3200	3400	3200
Stator Diameter	mm (in)	37 (1.46)	37 (1.46)	37 (1.46)	37 (1.46)
Stator Length	mm (in)	336 (13.23)	336 (13.23)	347 (13.66)	347 (13.66)
Stator Mass	g (lb)	1385 (3.05)	1385 (3.05)	1385 (3.05)	1385 (3.05)
Slider Diameter	mm (in)	20 (0.79)	20 (0.79)	20 (0.79)	20 (0.79)
Slider Length	mm (in)	1600 (62.99)	1600 (62.99)	1600 (62.99)	1600 (62.99)
Slider Mass	g (lb)	3622 (7.99)	3622 (7.99)	3622 (7.99)	3622 (7.99)
Position Repeatability	mm (in)	±0.05 (±0.0020)	±0.05 (±0.0020)	±0.05 (±0.0020)	±0.05 (±0.0020)
Linearity	%	±0.10	±0.10	±0.10	±0.10
Repeatability with EPS	mm (in)	±0.01 (±0.0004)	±0.01 (±0.0004)	±0.01 (±0.0004)	±0.01 (±0.0004)
Linearity with EPS	mm (in)	±0.01 (±0.0004)	±0.01 (±0.0004)	±0.01 (±0.0004)	±0.01 (±0.0004)

Position-Time Diagram

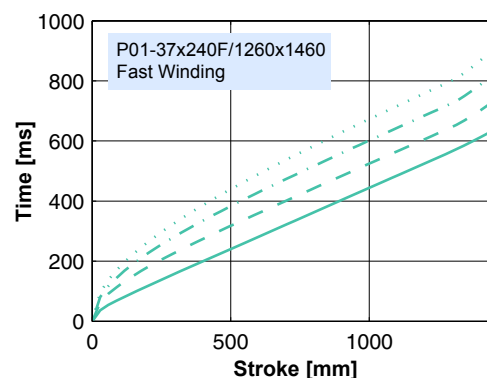
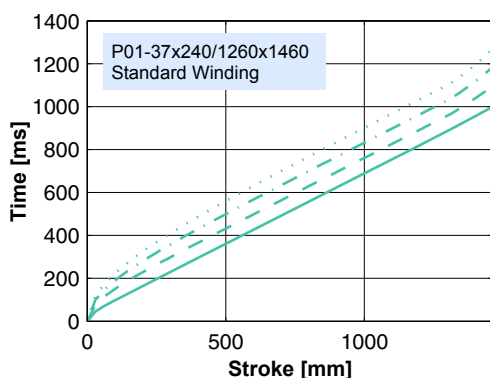

Connector Type

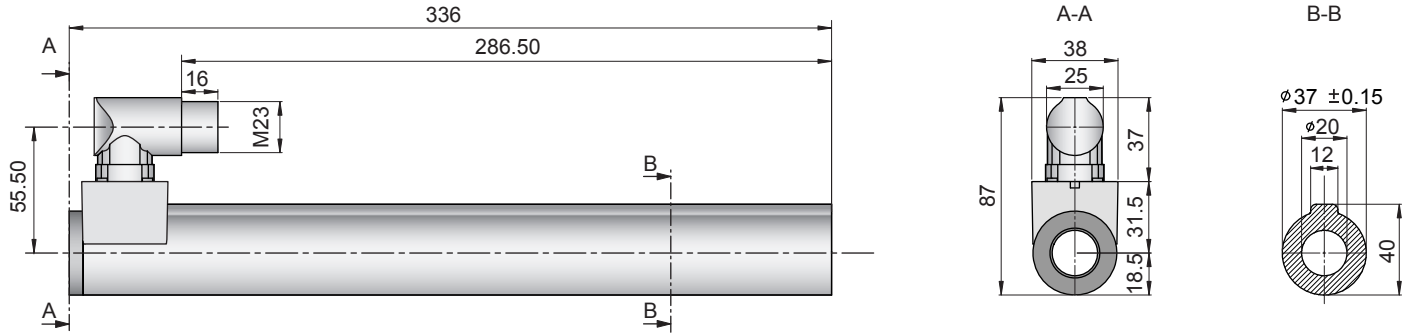

Linear Motor		Stator		Slider	
Type	Art.No	Type	Art. No.	Type	Art No.
P01-37x240/1260x1460-C	-->	PS01-37x240-C	0150-1224	& PL01-20x1600/1520	0150-1344
P01-37x240F/1260x1460-C	-->	PS01-37x240F-C	0150-1225	& PL01-20x1600/1520	0150-1344

Cable Type

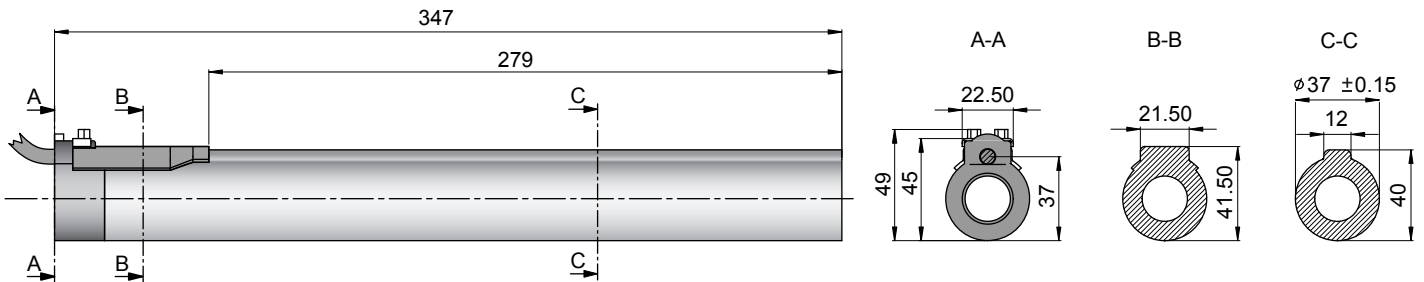

Linear Motor		Stator		Slider	
Type	Art.No	Type	Art. No.	Type	Art No.
P01-37x240/1260x1460-P150	-->	PS01-37x240-P150	0150-1203	& PL01-20x1600/1520	0150-1344
P01-37x240/1260x1460-C20	-->	PS01-37x240-C20	0150-1238	& PL01-20x1600/1520	0150-1344
P01-37x240F/1260x1460-C20	-->	PS01-37x240F-C20	0150-1239	& PL01-20x1600/1520	0150-1344

Slider

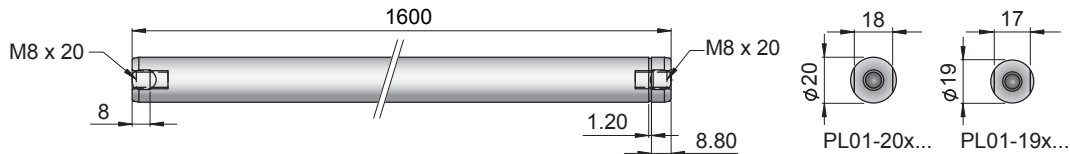

Standard Type	Slider Standard	PL01-20x1600/1520	0150-1344
Special Sliders	Heavy Duty Slider with WC/C-Coating	PL02-20x1600/1520	on request
	Hollow Slider hole diameter 6.5mm	PL01-20x1600/1520-L	on request

Connectors

Motor Connector Wiring

Cable Length:
P01-37x240... 1.5m
P01-37x240...-C20 0.2m

Ph	Color	Terminal	Case
Ph 1+	red	A	1
Ph 1-	pink	B	2
Ph 2+	blue	C	3
Ph 2-	grey	D	4
+5VDC	white	E	5
GND	inner Shield	F	6
Sine	yellow	G	7
Cosine	green	H	8
Temp.	black	L	9
Shield	outer Shield	Case	10

Accessoires

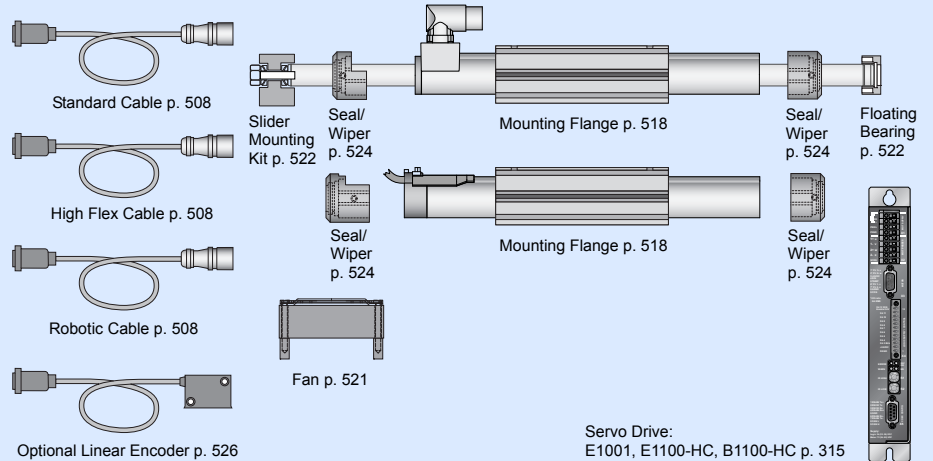

Servo Drive:
E1001, E1100-HC, B1100-HC p. 315



P01-48x240/30x180 138

P01-48x240/90x240 140

P01-48x240/180x330 142

P01-48x240/300x450 144

P01-48x240/390x540 146

P01-48x240/480x630 148

P01-48x240/600x750 150

P01-48x240/690x840 152

P01-48x240/900x1050 154

P01-48x240/1080x1230 156

P01-48x240/1290x1440 158

P01-48x240/1500x1650 160

P01-48x240/1680x1830 162

Max. Stroke: 180mm
Peak Force: 585N

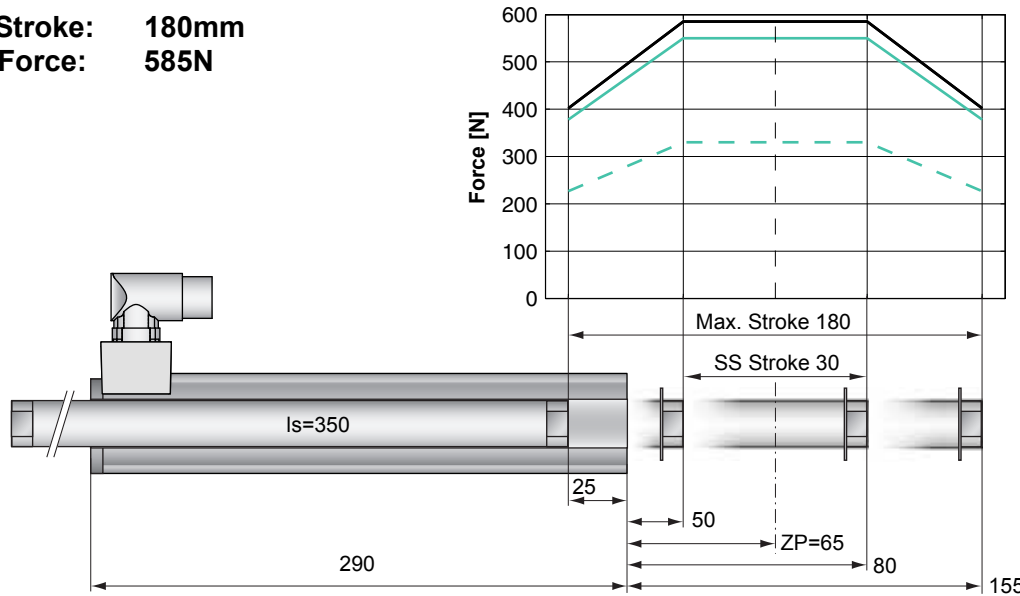

Dimensions in mm

Motor Specification

P01-		Standard Winding	Fast Winding
		48x240/30x180-C	48x240F/30x180-C
Extended Stroke ES	mm (in)	180 (7.09)	180 (7.09)
Standard Stroke SS	mm (in)	30 (1.18)	30 (1.18)
Peak Force E1100-XC	N (lbf)	585 (131.5)	550 (123.6)
Peak Force E1100-HC	N (lbf)	585 (131.5)	330 (74.2)
Cont. Force	N (lbf)	145 (32.5)	145 (32.6)
Cont. Force Fan cooling	N (lbf)	258 (58.0)	255 (57.3)
Border Force	%	69	69
Force Constant	N/A (lbf/A)	39.0 (8.77)	22.0 (4.95)
Max. Current @ 72VDC	A	15.0	26.0
Max. Current @ 48VDC	A	12.7	26.0
Max. Velocity @ 72VDC	m/s (in/s)	1.7 (67)	3.0 (119)
Max. Velocity @ 48VDC	m/s (in/s)	1.1 (45)	2.0 (79)
Phase Resist. 25/80 °C	Ohm	3.1/3.7	1.0/1.2
Phase Inductance	mH	3.1	1.0
Thermal Resistance	°K/W	1.1	1.1
Thermal Time Const.	sec	3000	3000
Stator Diameter	mm (in)	48 (1.89)	48 (1.89)
Stator Length	mm (in)	290 (11.40)	290 (11.40)
Stator Mass	g (lb)	1930 (4.25)	1930 (4.25)
Slider Diameter	mm (in)	28 (1.10)	28 (1.10)
Slider Length	mm (in)	350 (13.78)	350 (13.78)
Slider Mass	g (lb)	1460 (3.22)	1460 (3.22)
Position Repeatability	mm (in)	±0.05 (±0.0020)	±0.05 (±0.0020)
Linearity	%	±0.25	±0.25
Repeatability with EPS	mm (in)	±0.01 (±0.0004)	±0.01 (±0.0004)
Linearity with EPS	mm (in)	±0.01 (±0.0004)	±0.01 (±0.0004)

Position-Time Diagram

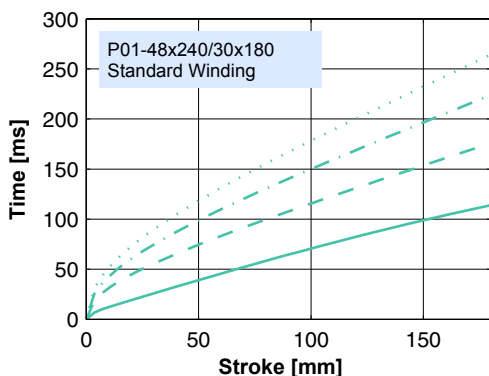

30.0 kg
 20.0 kg
 10.0 kg
 0.0 kg

Moving Slider

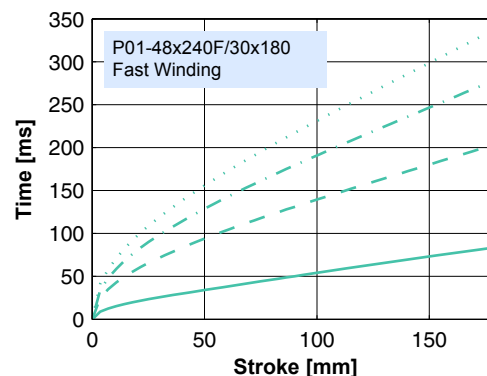

30.0 kg
 20.0 kg
 10.0 kg
 0.0 kg

Moving Slider

Connector Type

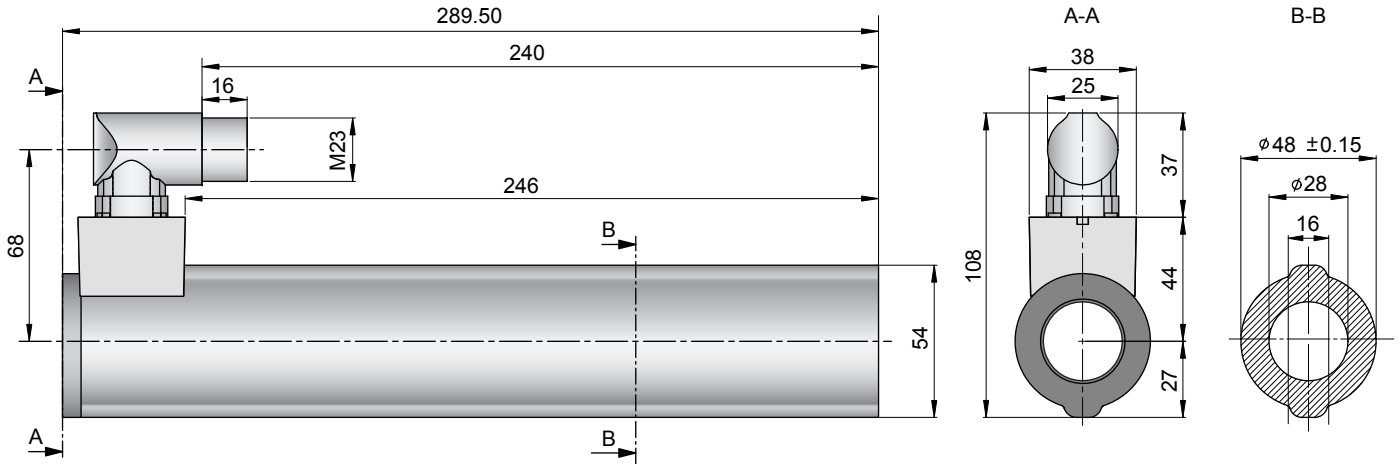

Linear Motor		Stator		Slider	
Type	Art.No	Type	Art. No.	Type	Art No.
P01-48x240/30x180-C	-->	PS01-48x240-C	0150-1219	& PL01-28x350/270	0150-1380
P01-48x240F/30x180-C	-->	PS01-48x240F-C	0150-1220	& PL01-28x350/270	0150-1380

Slider

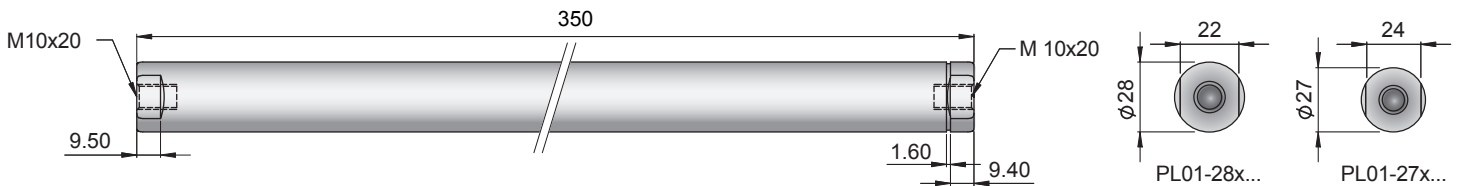

Standard Type	Slider Standard	PL01-28x350/270	0150-1380
Special Sliders	Heavy Duty Slider with WC/C-Coating	PL02-28x350/270	0150-1411
	Hollow Slider hole diameter 8.5mm	PL01-28x350/270-L	0150-1475
	High Clearance Slider d=27mm, m=1360g	PL01-27x350/270	0150-1467

Connectors

Motor Connector Wiring

		P01-48...-C
Ph 1+	red	A
Ph 1-	pink	B
Ph 2+	blue	C
Ph 2-	grey	D
+5VDC	white	E
GND	inner Shield	F
Sine	yellow	G
Cosine	green	H
Temp.	black	L
Shield	outer Shield	Case

Accessoires

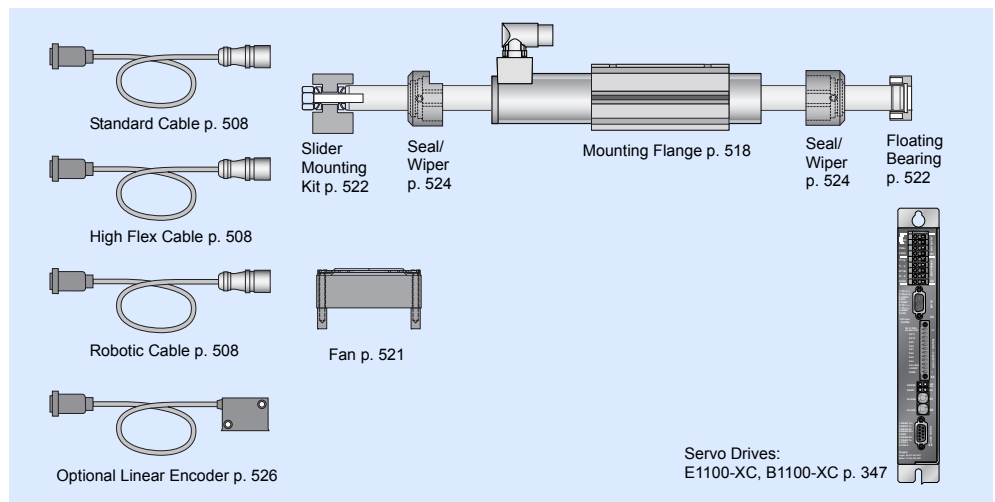

Max. Stroke: 240mm
Peak Force: 585N

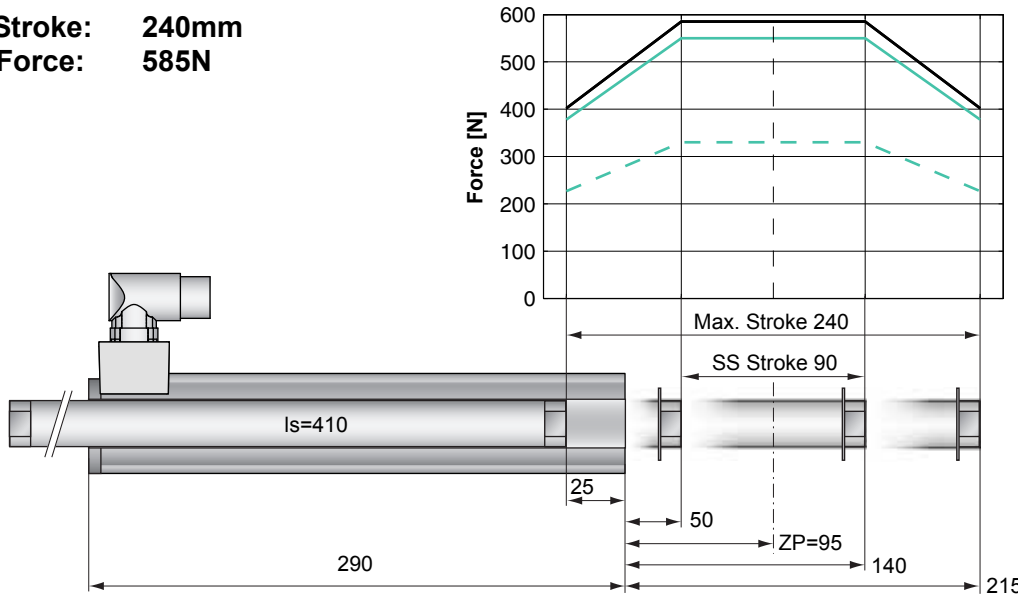

Dimensions in mm

Motor Specification

P01-		Standard Winding	Fast Winding
		48x240/90x240-C	48x240F/90x240-C
Extended Stroke ES	mm (in)	240 (9.45)	240 (9.45)
Standard Stroke SS	mm (in)	90 (3.54)	90 (3.54)
Peak Force E1100-XC	N (lbf)	585 (131.5)	550 (123.6)
Peak Force E1100-HC	N (lbf)	585 (131.5)	330 (74.2)
Cont. Force	N (lbf)	145 (32.5)	145 (32.6)
Cont. Force Fan cooling	N (lbf)	258 (58.0)	255 (57.3)
Border Force	%	69	69
Force Constant	N/A (lbf/A)	39.0 (8.77)	22.0 (4.95)
Max. Current @ 72VDC	A	15.0	26.0
Max. Current @ 48VDC	A	12.7	26.0
Max. Velocity @ 72VDC	m/s (in/s)	1.7 (67)	3.0 (119)
Max. Velocity @ 48VDC	m/s (in/s)	1.1 (45)	2.0 (79)
Phase Resist. 25/80 °C	Ohm	3.1/3.7	1.0/1.2
Phase Inductance	mH	3.1	1.0
Thermal Resistance	°K/W	1.1	1.1
Thermal Time Const.	sec	3000	3000
Stator Diameter	mm (in)	48 (1.89)	48 (1.89)
Stator Length	mm (in)	290 (11.40)	290 (11.40)
Stator Mass	g (lb)	1930 (4.25)	1930 (4.25)
Slider Diameter	mm (in)	28 (1.10)	28 (1.10)
Slider Length	mm (in)	410 (16.14)	410 (16.14)
Slider Mass	g (lb)	1740 (3.84)	1740 (3.84)
Position Repeatability	mm (in)	±0.05 (±0.0020)	±0.05 (±0.0020)
Linearity	%	±0.20	±0.20
Repeatability with EPS	mm (in)	±0.01 (±0.0004)	±0.01 (±0.0004)
Linearity with EPS	mm (in)	±0.01 (±0.0004)	±0.01 (±0.0004)

Position-Time Diagram

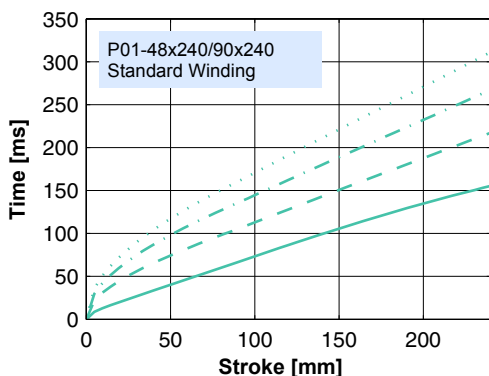

30.0 kg
 20.0 kg
 10.0 kg
 0.0 kg

Moving Slider

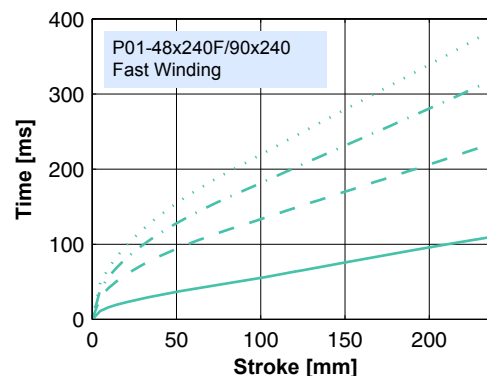

30.0 kg
 20.0 kg
 10.0 kg
 0.0 kg

Moving Slider

Connector Type

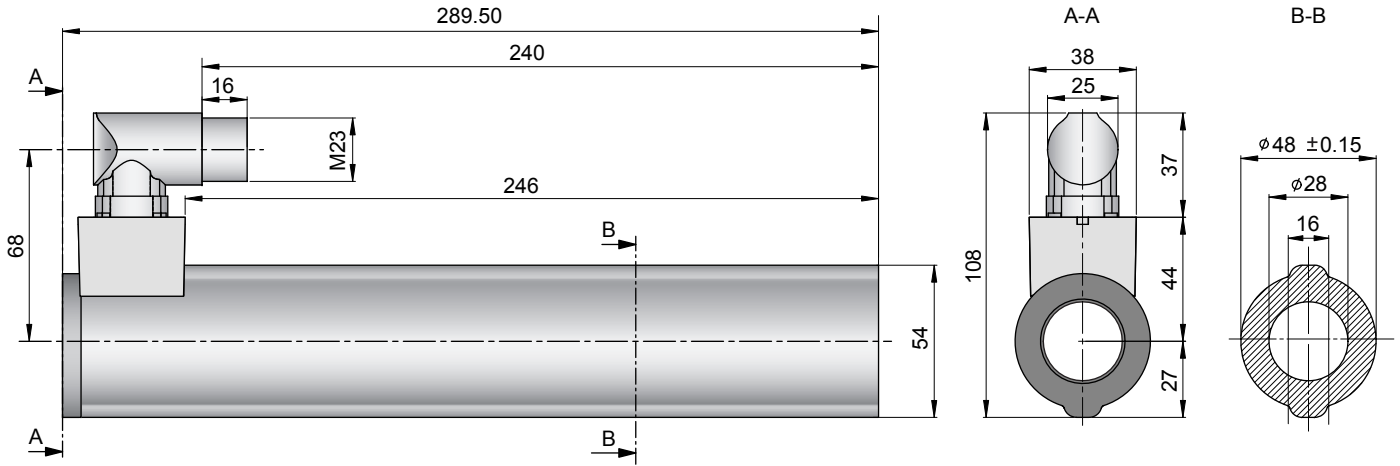

Linear Motor		Stator		Slider	
Type	Art.No	Type	Art. No.	Type	Art No.
P01-48x240/90x240-C	-->	PS01-48x240-C	0150-1219	& PL01-28x410/330	0150-1381
P01-48x240F/90x240-C	-->	PS01-48x240F-C	0150-1220	& PL01-28x410/330	0150-1381

Slider

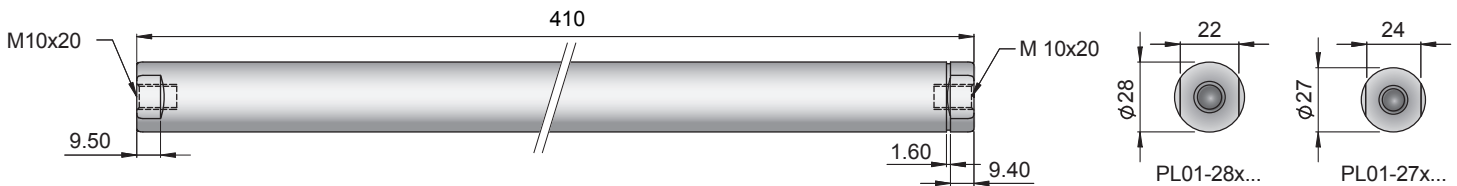

Standard Type	Slider Standard	PL01-28x410/330	0150-1381
Special Sliders	Heavy Duty Slider with WC/C-Coating	PL02-28x410/330	0150-1412
	Hollow Slider hole diameter 8.5mm	PL01-28x410/330-L	0150-1476
	High Clearance Slider d=27mm, m=1620g	PL01-27x410/330	0150-1468

Connectors

Motor Connector Wiring

		P01-48...-C
Ph 1+	red	A
Ph 1-	pink	B
Ph 2+	blue	C
Ph 2-	grey	D
+5VDC	white	E
GND	inner Shield	F
Sine	yellow	G
Cosine	green	H
Temp.	black	L
Shield	outer Shield	Case

Accessoires

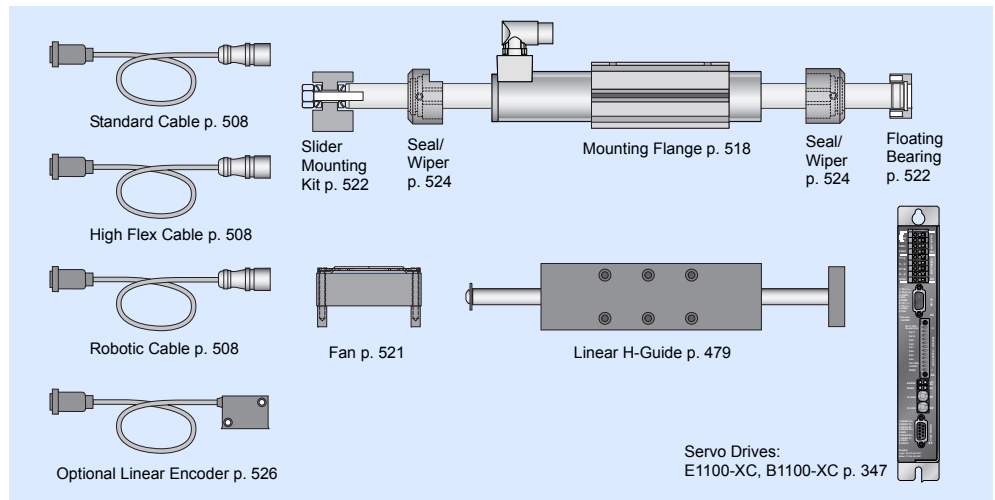

Max. Stroke: 330mm
Peak Force: 585N

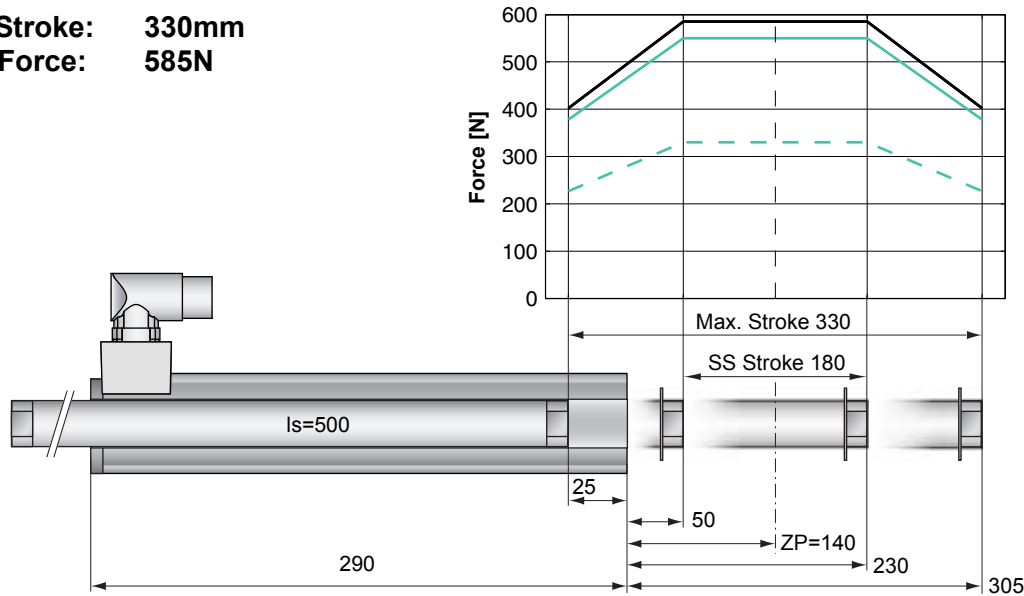

Standard Winding:
 — E1100-XC, 72VDC
 — E1100-HC, 72VDC

Fast Winding:
 — E1100-XC, 72VDC
 - - E1100-HC, 72VDC

Dimensions in mm

Motor Specification

	P01-	Standard Winding	Fast Winding
		48x240/180x330-C	48x240F/180x330-C
Extended Stroke ES	mm (in)	330 (12.99)	330 (12.99)
Standard Stroke SS	mm (in)	180 (7.09)	180 (7.09)
Peak Force E1100-XC	N (lbf)	585 (131.5)	550 (123.6)
Peak Force E1100-HC	N (lbf)	585 (131.5)	330 (74.2)
Cont. Force	N (lbf)	145 (32.5)	145 (32.6)
Cont. Force Fan cooling	N (lbf)	258 (58.0)	255 (57.3)
Border Force	%	69	69
Force Constant	N/A (lbf/A)	39.0 (8.77)	22.0 (4.95)
Max. Current @ 72VDC	A	15.0	26.0
Max. Current @ 48VDC	A	12.7	26.0
Max. Velocity @ 72VDC	m/s (in/s)	1.7 (67)	3.0 (119)
Max. Velocity @ 48VDC	m/s (in/s)	1.1 (45)	2.0 (79)
Phase Resist. 25/80 °C	Ohm	3.1/3.7	1.0/1.2
Phase Inductance	mH	3.1	1.0
Thermal Resistance	°K/W	1.1	1.1
Thermal Time Const.	sec	3000	3000
Stator Diameter	mm (in)	48 (1.89)	48 (1.89)
Stator Length	mm (in)	290 (11.40)	290 (11.40)
Stator Mass	g (lb)	1930 (4.25)	1930 (4.25)
Slider Diameter	mm (in)	28 (1.10)	28 (1.10)
Slider Length	mm (in)	500 (19.69)	500 (19.69)
Slider Mass	g (lb)	2160 (4.76)	2160 (4.76)
Position Repeatability	mm (in)	±0.05 (±0.0020)	±0.05 (±0.0020)
Linearity	%	±0.15	±0.15
Repeatability with EPS	mm (in)	±0.01 (±0.0004)	±0.01 (±0.0004)
Linearity with EPS	mm (in)	±0.01 (±0.0004)	±0.01 (±0.0004)

Position-Time Diagram

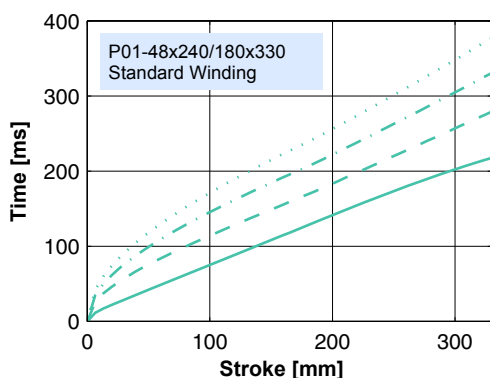

30.0 kg
 20.0 kg
 10.0 kg
 0.0 kg

Moving Slider

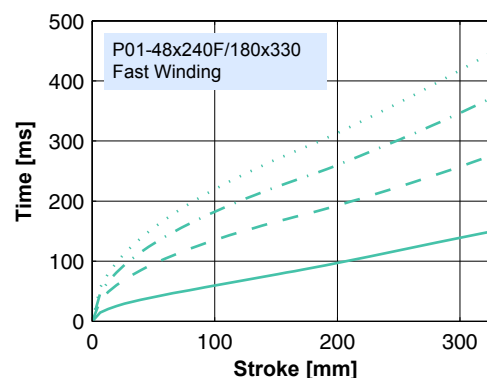

30.0 kg
 20.0 kg
 10.0 kg
 0.0 kg

Moving Slider

Connector Type

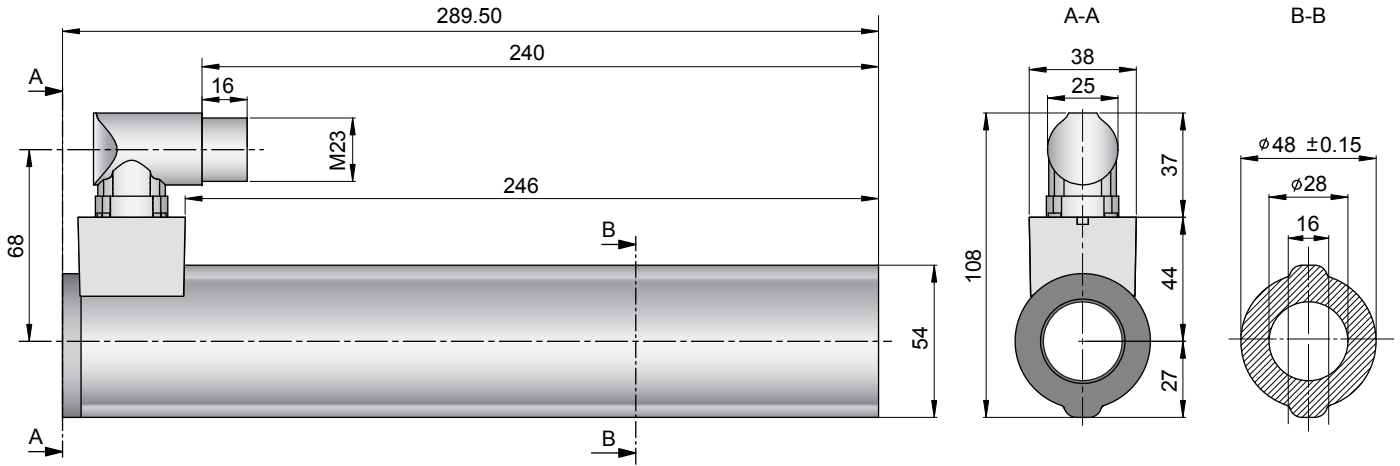

Linear Motor		Stator		Slider	
Type	Art.No	Type	Art. No.	Type	Art No.
P01-48x240/180x330-C	-->	PS01-48x240-C	0150-1219	& PL01-28x500/420	0150-1382
P01-48x240F/180x330-C	-->	PS01-48x240F-C	0150-1220	& PL01-28x500/420	0150-1382

Slider

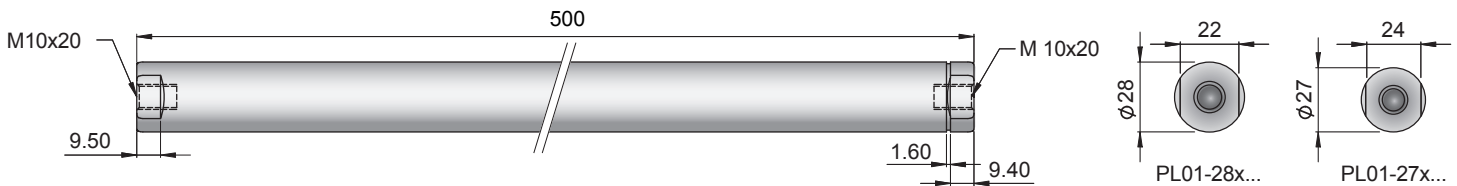

Standard Type	Slider Standard	PL01-28x500/420	0150-1382
Special Sliders	Heavy Duty Slider with WC/C-Coating	PL02-28x500/420	0150-1413
	Hollow Slider hole diameter 8.5mm	PL01-28x500/420-L	0150-1480
	High Clearance Slider d=27mm, m=2010g	PL01-27x500/420	0150-1469

Connectors

Motor Connector Wiring

		P01-48...-C
Ph 1+	red	A
Ph 1-	pink	B
Ph 2+	blue	C
Ph 2-	grey	D
+5VDC	white	E
GND	inner Shield	F
Sine	yellow	G
Cosine	green	H
Temp.	black	L
Shield	outer Shield	Case

Accessoires

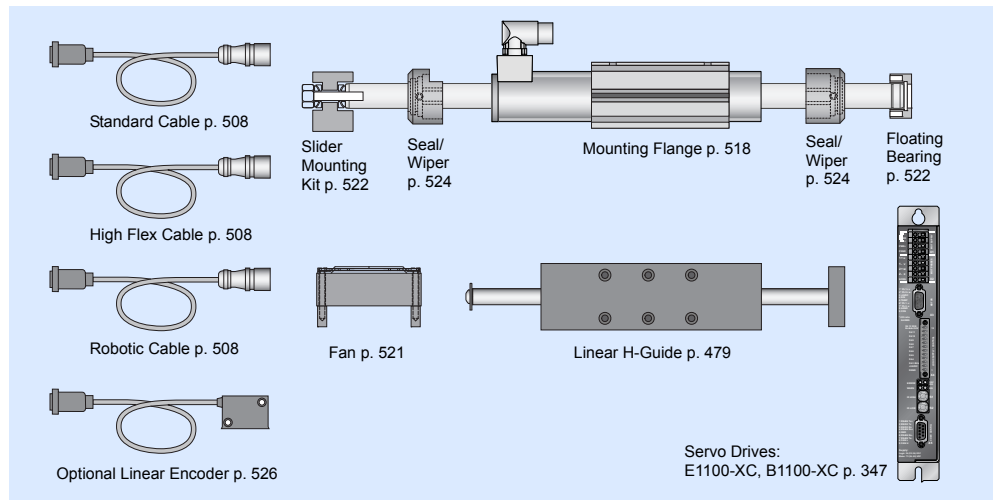

Max. Stroke: 450mm
Peak Force: 585N

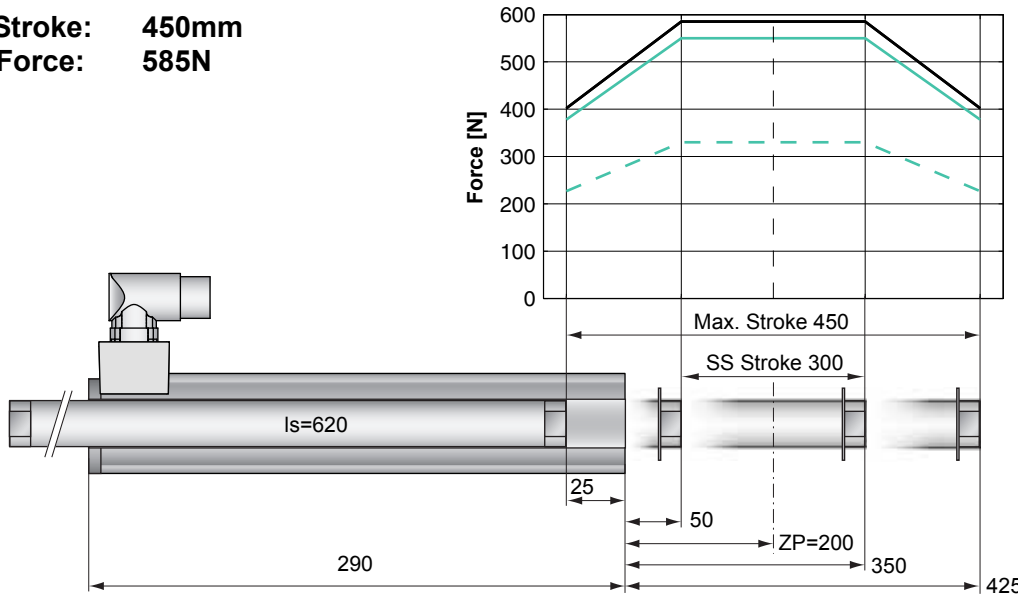

Standard Winding:
 — E1100-XC, 72VDC
 - - E1100-HC, 72VDC

Fast Winding:
 — E1100-XC, 72VDC
 - - E1100-HC, 72VDC

Dimensions in mm

Motor Specification

P01-		Standard Winding	Fast Winding
		48x240/300x450-C	48x240F/300x450-C
Extended Stroke ES	mm (in)	450 (17.72)	450 (17.72)
Standard Stroke SS	mm (in)	300 (11.81)	300 (11.81)
Peak Force E1100-XC	N (lbf)	585 (131.5)	550 (123.6)
Peak Force E1100-HC	N (lbf)	585 (131.5)	330 (74.2)
Cont. Force	N (lbf)	145 (32.5)	145 (32.6)
Cont. Force Fan cooling	N (lbf)	258 (58.0)	255 (57.3)
Border Force	%	69	69
Force Constant	N/A (lbf/A)	39.0 (8.77)	22.0 (4.95)
Max. Current @ 72VDC	A	15.0	26.0
Max. Current @ 48VDC	A	12.7	26.0
Max. Velocity @ 72VDC	m/s (in/s)	1.7 (67)	3.0 (119)
Max. Velocity @ 48VDC	m/s (in/s)	1.1 (45)	2.0 (79)
Phase Resist. 25/80 °C	Ohm	3.1/3.7	1.0/1.2
Phase Inductance	mH	3.1	1.0
Thermal Resistance	°K/W	1.1	1.1
Thermal Time Const.	sec	3000	3000
Stator Diameter	mm (in)	48 (1.89)	48 (1.89)
Stator Length	mm (in)	290 (11.40)	290 (11.40)
Stator Mass	g (lb)	1930 (4.25)	1930 (4.25)
Slider Diameter	mm (in)	28 (1.10)	28 (1.10)
Slider Length	mm (in)	620 (24.41)	620 (24.41)
Slider Mass	g (lb)	2720 (6.00)	2720 (6.00)
Position Repeatability	mm (in)	±0.05 (±0.0020)	±0.05 (±0.0020)
Linearity	%	±0.15	±0.15
Repeatability with EPS	mm (in)	±0.01 (±0.0004)	±0.01 (±0.0004)
Linearity with EPS	mm (in)	±0.01 (±0.0004)	±0.01 (±0.0004)

Position-Time Diagram

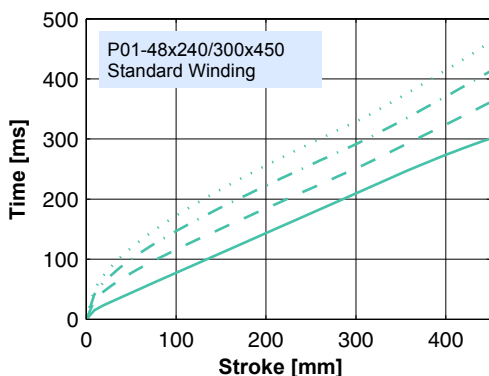

30.0 kg
 20.0 kg
 10.0 kg
 0.0 kg

Moving Slider

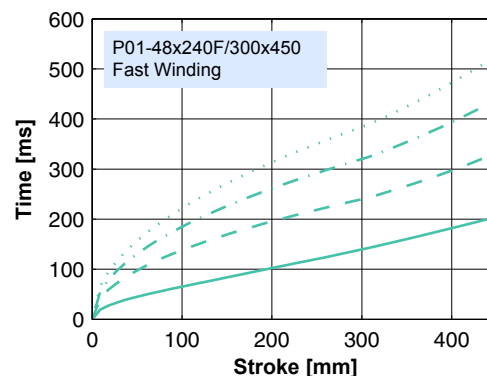

30.0 kg
 20.0 kg
 10.0 kg
 0.0 kg

Moving Slider

Connector Type

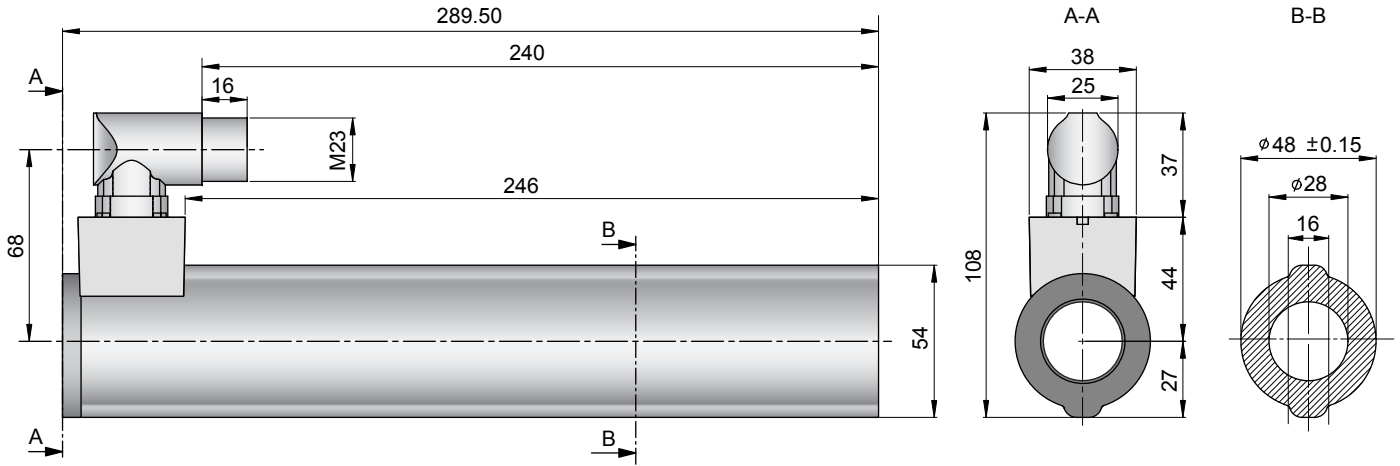

Linear Motor		Stator		Slider	
Type	Art.No	Type	Art. No.	Type	Art No.
P01-48x240/300x450-C	-->	PS01-48x240-C	0150-1219	& PL01-28x620/540	0150-1383
P01-48x240F/300x450-C	-->	PS01-48x240F-C	0150-1220	& PL01-28x620/540	0150-1383

Slider

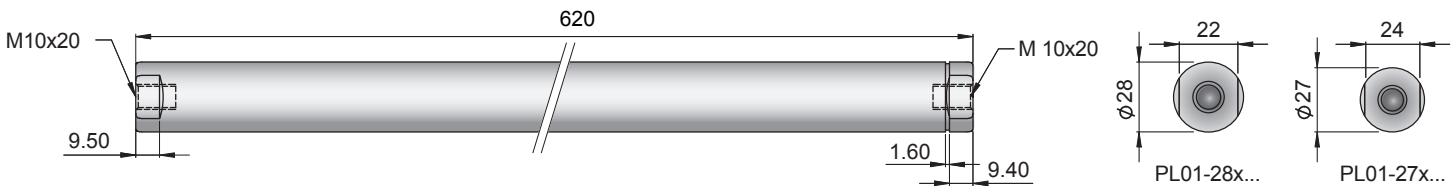

Standard Type	Slider Standard	PL01-28x620/540	0150-1383
Special Sliders	Heavy Duty Slider with WC/C-Coating	PL02-28x620/540	0150-1414
	Hollow Slider hole diameter 8.5mm	PL01-28x620/540-L	0150-1481
	High Clearance Slider d=27mm, m=2530g	PL01-27x620/540	0150-1470

Connectors

Motor Connector Wiring

		P01-48...-C
Ph 1+	red	A
Ph 1-	pink	B
Ph 2+	blue	C
Ph 2-	grey	D
+5VDC	white	E
GND	inner Shield	F
Sine	yellow	G
Cosine	green	H
Temp.	black	L
Shield	outer Shield	Case

Accessoires

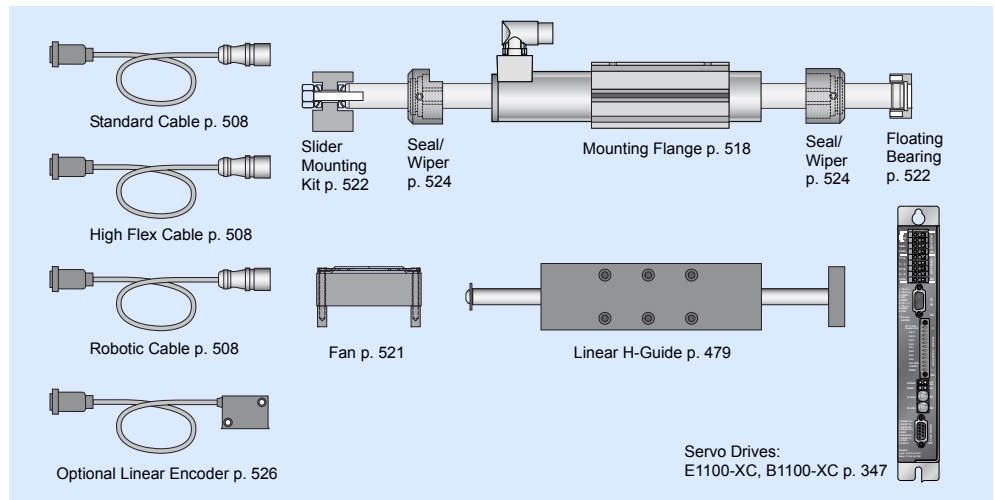

Max. Stroke: 540mm
Peak Force: 585N

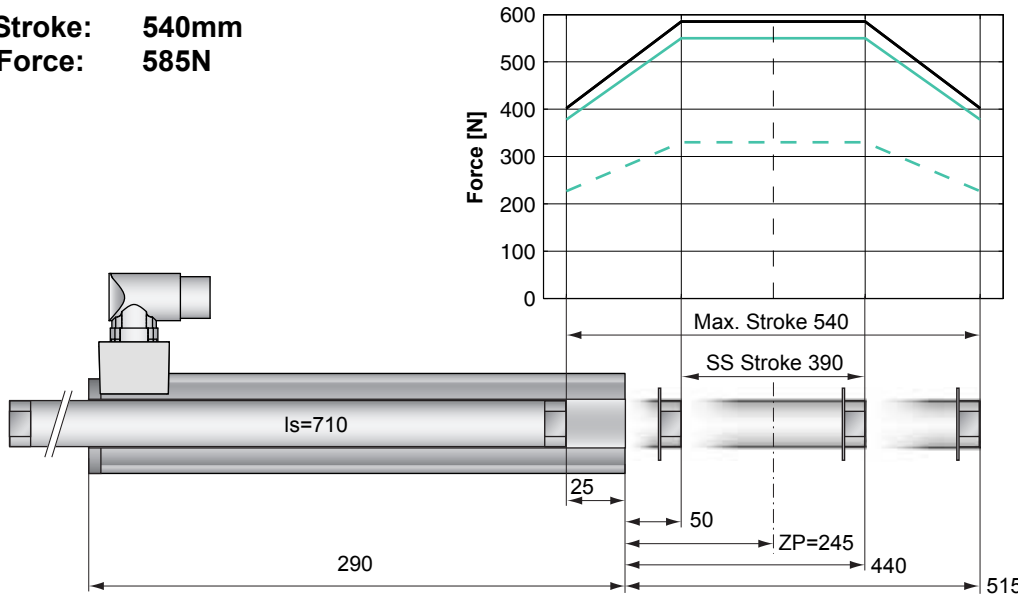

Dimensions in mm

Motor Specification

	P01-	Standard Winding	Fast Winding
		48x240/390x540-C	48x240F/390x540-C
Extended Stroke ES	mm (in)	540 (21.26)	540 (21.26)
Standard Stroke SS	mm (in)	390 (15.35)	390 (15.35)
Peak Force E1100-XC	N (lbf)	585 (131.5)	550 (123.6)
Peak Force E1100-HC	N (lbf)	585 (131.5)	330 (74.2)
Cont. Force	N (lbf)	145 (32.5)	145 (32.6)
Cont. Force Fan cooling	N (lbf)	258 (58.0)	255 (57.3)
Border Force	%	69	69
Force Constant	N/A (lbf/A)	39.0 (8.77)	22.0 (4.95)
Max. Current @ 72VDC	A	15.0	26.0
Max. Current @ 48VDC	A	12.7	26.0
Max. Velocity @ 72VDC	m/s (in/s)	1.7 (67)	3.0 (119)
Max. Velocity @ 48VDC	m/s (in/s)	1.1 (45)	2.0 (79)
Phase Resist. 25/80 °C	Ohm	3.1/3.7	1.0/1.2
Phase Inductance	mH	3.1	1.0
Thermal Resistance	°K/W	1.1	1.1
Thermal Time Const.	sec	3000	3000
Stator Diameter	mm (in)	48 (1.89)	48 (1.89)
Stator Length	mm (in)	290 (11.40)	290 (11.40)
Stator Mass	g (lb)	1930 (4.25)	1930 (4.25)
Slider Diameter	mm (in)	28 (1.10)	28 (1.10)
Slider Length	mm (in)	710 (27.95)	710 (27.95)
Slider Mass	g (lb)	3140 (6.92)	3140 (6.92)
Position Repeatability	mm (in)	±0.05 (±0.0020)	±0.05 (±0.0020)
Linearity	%	±0.15	±0.15
Repeatability with EPS	mm (in)	±0.01 (±0.0004)	±0.01 (±0.0004)
Linearity with EPS	mm (in)	±0.01 (±0.0004)	±0.01 (±0.0004)

Position-Time Diagram

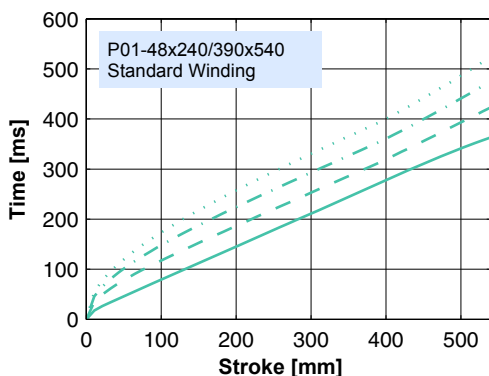

30.0 kg
 20.0 kg
 10.0 kg
 0.0 kg

Moving Slider

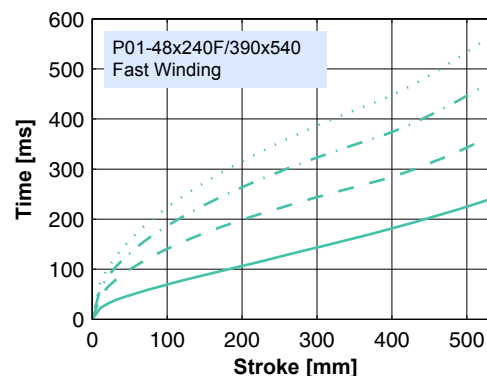

30.0 kg
 20.0 kg
 10.0 kg
 0.0 kg

Moving Slider

Connector Type

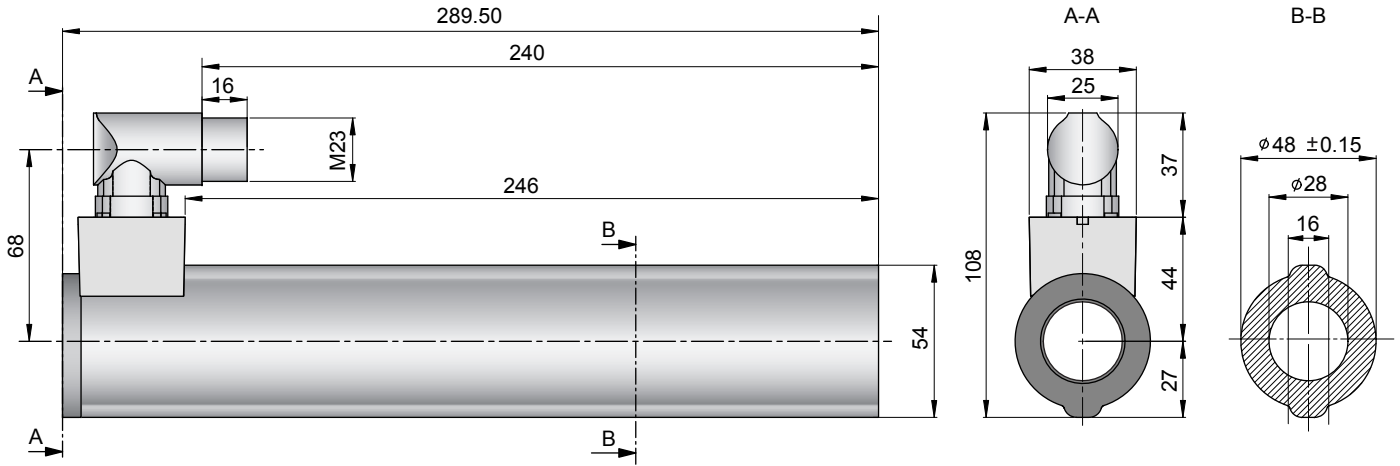

Linear Motor		Stator		Slider	
Type	Art.No	Type	Art. No.	Type	Art No.
P01-48x240/390x540-C	-->	PS01-48x240-C	0150-1219	& PL01-28x710/630	0150-1384
P01-48x240F/390x540-C	-->	PS01-48x240F-C	0150-1220	& PL01-28x710/630	0150-1384

Slider

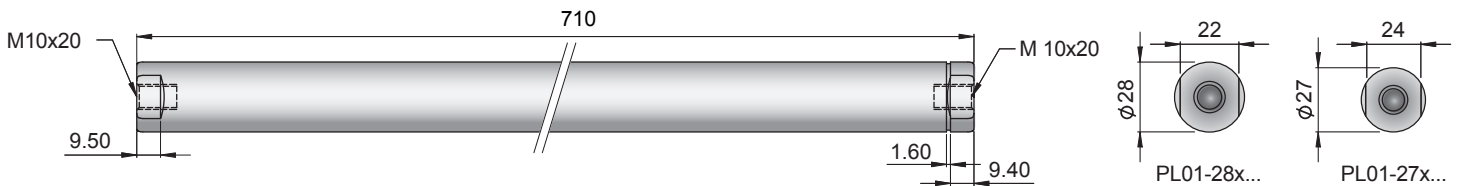

Standard Type	Slider Standard	PL01-28x710/630	0150-1384
Special Sliders	Heavy Duty Slider with WC/C-Coating	PL02-28x710/630	0150-1415
	Hollow Slider hole diameter 8.5mm	PL01-28x710/630-L	0150-1482
	High Clearance Slider d=27mm, m=2920g	PL01-27x710/630	0150-1471

Connectors

Motor Connector Wiring

		P01-48...-C
Ph 1+	red	A
Ph 1-	pink	B
Ph 2+	blue	C
Ph 2-	grey	D
+5VDC	white	E
GND	inner Shield	F
Sine	yellow	G
Cosine	green	H
Temp.	black	L
Shield	outer Shield	Case

Accessoires

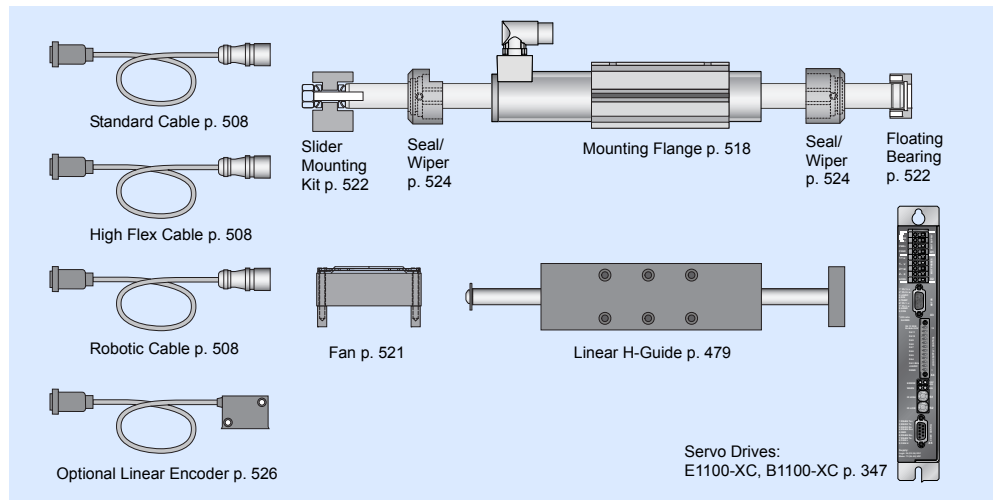

Max. Stroke: 630mm
Peak Force: 585N

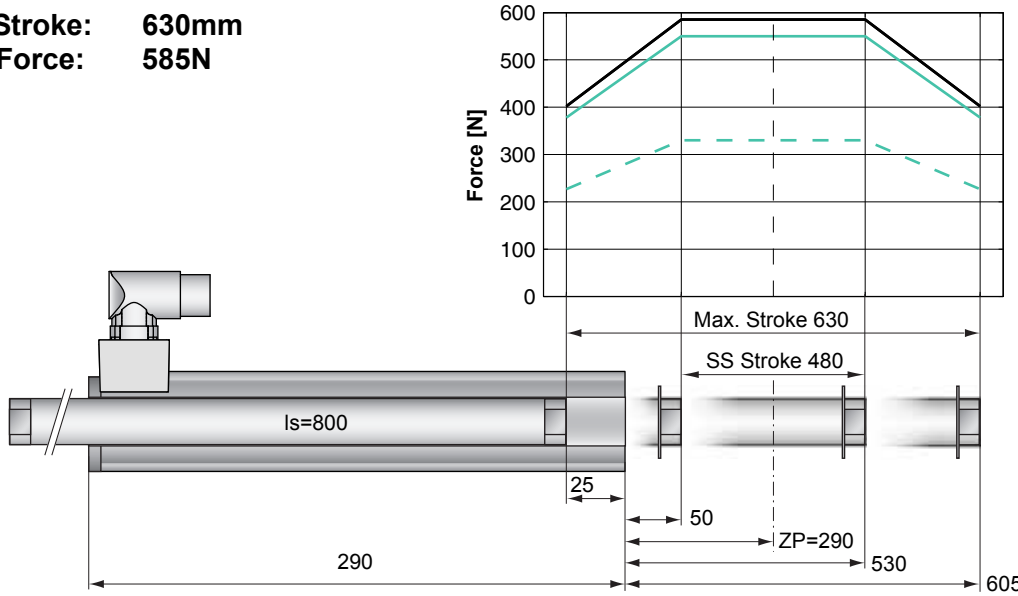

Dimensions in mm

Motor Specification

	P01-	Standard Winding	Fast Winding
		48x240/480x630-C	48x240F/480x630-C
Extended Stroke ES	mm (in)	630 (24.80)	630 (24.80)
Standard Stroke SS	mm (in)	480 (18.90)	480 (18.90)
Peak Force E1100-XC	N (lbf)	585 (131.5)	550 (123.6)
Peak Force E1100-HC	N (lbf)	585 (131.5)	330 (74.2)
Cont. Force	N (lbf)	145 (32.5)	145 (32.6)
Cont. Force Fan cooling	N (lbf)	258 (58.0)	255 (57.3)
Border Force	%	69	69
Force Constant	N/A (lbf/A)	39.0 (8.77)	22.0 (4.95)
Max. Current @ 72VDC	A	15.0	26.0
Max. Current @ 48VDC	A	12.7	26.0
Max. Velocity @ 72VDC	m/s (in/s)	1.7 (67)	3.0 (119)
Max. Velocity @ 48VDC	m/s (in/s)	1.1 (45)	2.0 (79)
Phase Resist. 25/80 °C	Ohm	3.1/3.7	1.0/1.2
Phase Inductance	mH	3.1	1.0
Thermal Resistance	°K/W	1.1	1.1
Thermal Time Const.	sec	3000	3000
Stator Diameter	mm (in)	48 (1.89)	48 (1.89)
Stator Length	mm (in)	290 (11.40)	290 (11.40)
Stator Mass	g (lb)	1930 (4.25)	1930 (4.25)
Slider Diameter	mm (in)	28 (1.10)	28 (1.10)
Slider Length	mm (in)	800 (31.50)	800 (31.50)
Slider Mass	g (lb)	3560 (7.85)	3560 (7.85)
Position Repeatability	mm (in)	±0.05 (±0.0020)	±0.05 (±0.0020)
Linearity	%	±0.10	±0.10
Repeatability with EPS	mm (in)	±0.01 (±0.0004)	±0.01 (±0.0004)
Linearity with EPS	mm (in)	±0.01 (±0.0004)	±0.01 (±0.0004)

Position-Time Diagram

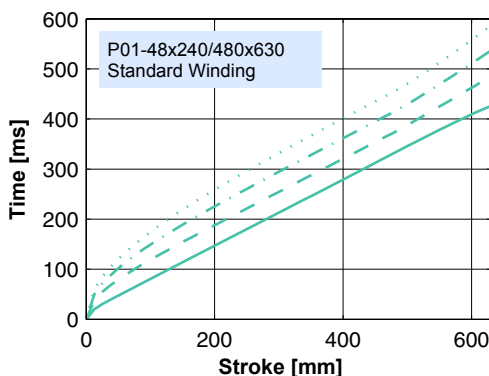

30.0 kg
 20.0 kg
 10.0 kg
 0.0 kg

Moving Slider

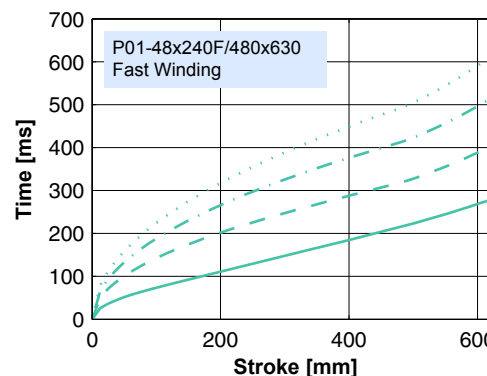

30.0 kg
 20.0 kg
 10.0 kg
 0.0 kg

Moving Slider

Connector Type

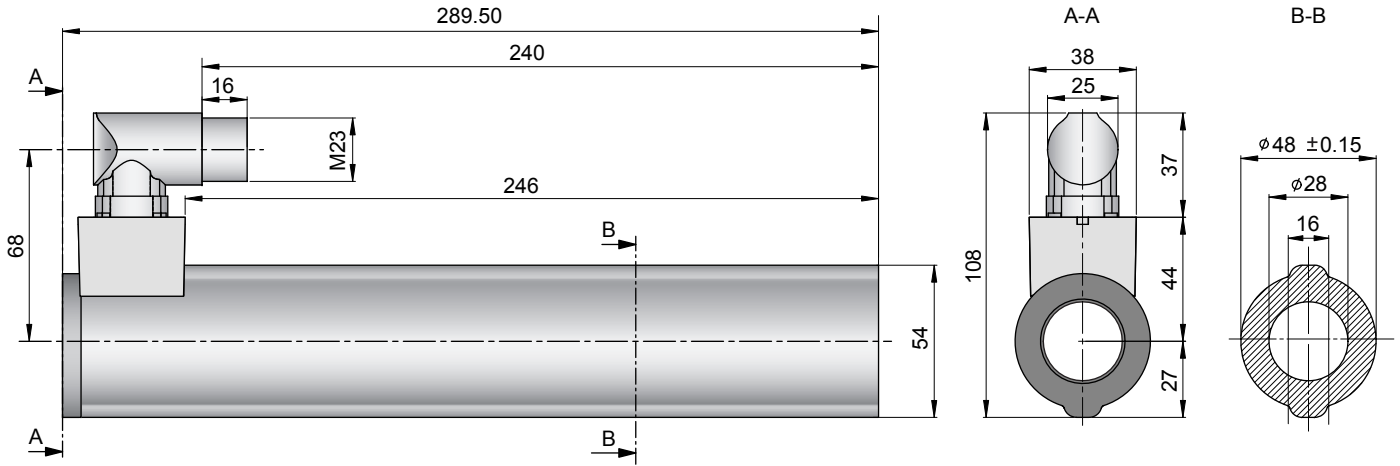

Linear Motor		Stator		Slider	
Type	Art.No	Type	Art. No.	Type	Art No.
P01-48x240/480x630-C	-->	PS01-48x240-C	0150-1219	& PL01-28x800/720	0150-1385
P01-48x240F/480x630-C	-->	PS01-48x240F-C	0150-1220	& PL01-28x800/720	0150-1385

Slider

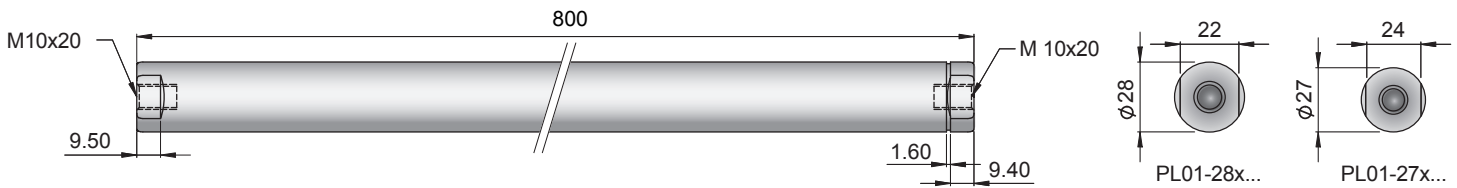

Standard Type	Slider Standard	PL01-28x800/720	0150-1385
Special Sliders	Heavy Duty Slider with WC/C-Coating	PL02-28x800/720	0150-1416
	Hollow Slider hole diameter 8.5mm	PL01-28x800/720-L	0150-1483

Connectors

Motor Connector Wiring

		P01-48...-C
Ph 1+	red	A
Ph 1-	pink	B
Ph 2+	blue	C
Ph 2-	grey	D
+5VDC	white	E
GND	inner Shield	F
Sine	yellow	G
Cosine	green	H
Temp.	black	L
Shield	outer Shield	Case

Accessoires

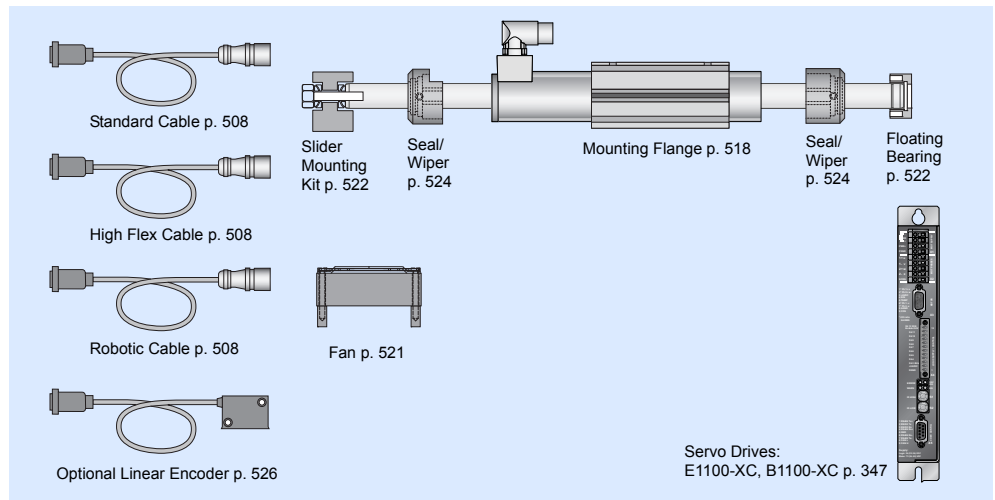

Max. Stroke: 750mm
Peak Force: 585N

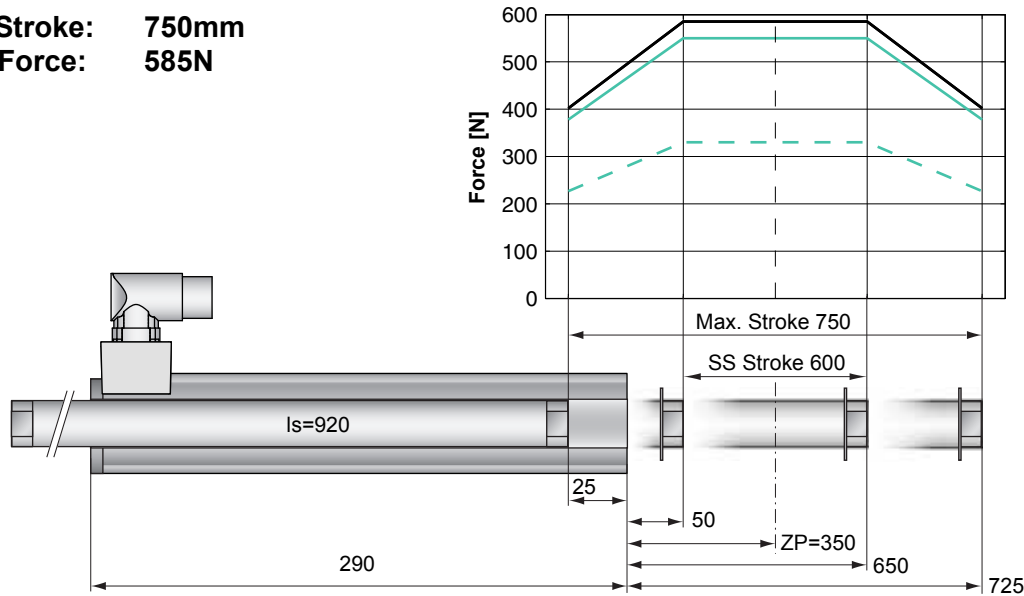

Dimensions in mm

Motor Specification

	P01-	Standard Winding	Fast Winding
		48x240/600x750-C	48x240F/600x750-C
Extended Stroke ES	mm (in)	750 (29.53)	750 (29.53)
Standard Stroke SS	mm (in)	600 (23.62)	600 (23.62)
Peak Force E1100-XC	N (lbf)	585 (131.5)	550 (123.6)
Peak Force E1100-HC	N (lbf)	585 (131.5)	330 (74.2)
Cont. Force	N (lbf)	145 (32.5)	145 (32.6)
Cont. Force Fan cooling	N (lbf)	258 (58.0)	255 (57.3)
Border Force	%	69	69
Force Constant	N/A (lbf/A)	39.0 (8.77)	22.0 (4.95)
Max. Current @ 72VDC	A	15.0	26.0
Max. Current @ 48VDC	A	12.7	26.0
Max. Velocity @ 72VDC	m/s (in/s)	1.7 (67)	3.0 (119)
Max. Velocity @ 48VDC	m/s (in/s)	1.1 (45)	2.0 (79)
Phase Resist. 25/80 °C	Ohm	3.1/3.7	1.0/1.2
Phase Inductance	mH	3.1	1.0
Thermal Resistance	°K/W	1.1	1.1
Thermal Time Const.	sec	3000	3000
Stator Diameter	mm (in)	48 (1.89)	48 (1.89)
Stator Length	mm (in)	290 (11.40)	290 (11.40)
Stator Mass	g (lb)	1930 (4.25)	1930 (4.25)
Slider Diameter	mm (in)	28 (1.10)	28 (1.10)
Slider Length	mm (in)	920 (36.22)	920 (36.22)
Slider Mass	g (lb)	4120 (9.08)	4120 (9.08)
Position Repeatability	mm (in)	±0.05 (±0.0020)	±0.05 (±0.0020)
Linearity	%	±0.10	±0.10
Repeatability with EPS	mm (in)	±0.01 (±0.0004)	±0.01 (±0.0004)
Linearity with EPS	mm (in)	±0.01 (±0.0004)	±0.01 (±0.0004)

Position-Time Diagram

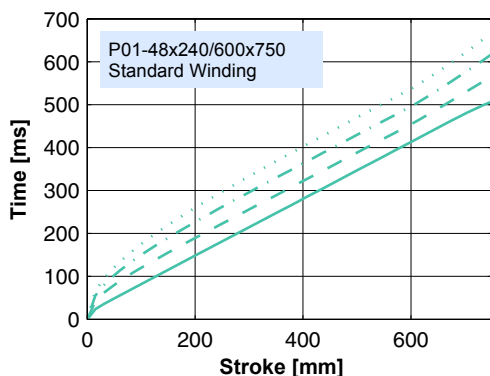

30.0 kg
 20.0 kg
 10.0 kg
 0.0 kg

Moving Stator

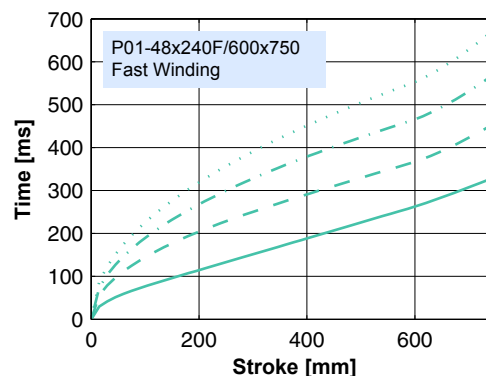

30.0 kg
 20.0 kg
 10.0 kg
 0.0 kg

Moving Stator

Connector Type

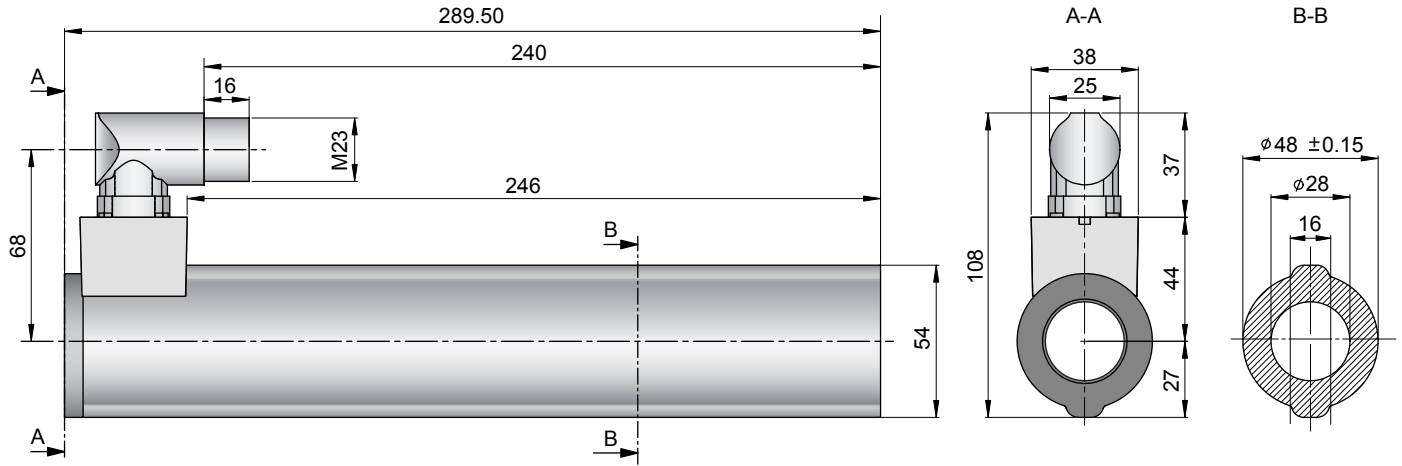

Linear Motor		Stator		Slider	
Type	Art.No	Type	Art. No.	Type	Art No.
P01-48x240/600x750-C	-->	PS01-48x240-C	0150-1219	& PL01-28x920/840	0150-1386
P01-48x240F/600x750-C	-->	PS01-48x240F-C	0150-1220	& PL01-28x920/840	0150-1386

Slider

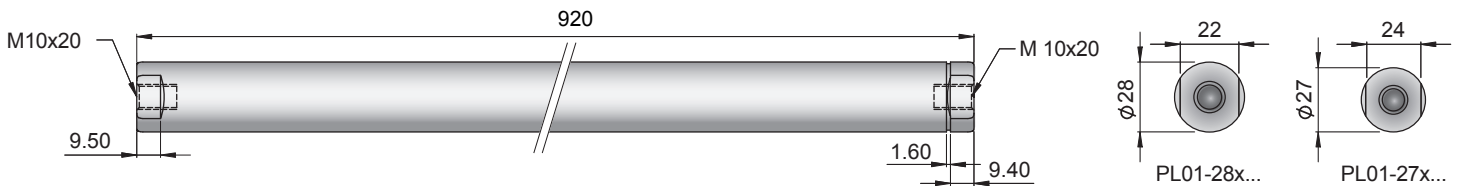

Standard Type	Slider Standard	PL01-28x920/840	0150-1386
Special Sliders	Heavy Duty Slider with WC/C-Coating	PL02-28x920/840	0150-1417
	Hollow Slider hole diameter 8.5mm	PL01-28x920/840-L	on request

Connectors

Motor Connector Wiring

		P01-48...-C
Ph 1+	red	A
Ph 1-	pink	B
Ph 2+	blue	C
Ph 2-	grey	D
+5VDC	white	E
GND	inner Shield	F
Sine	yellow	G
Cosine	green	H
Temp.	black	L
Shield	outer Shield	Case

Accessoires

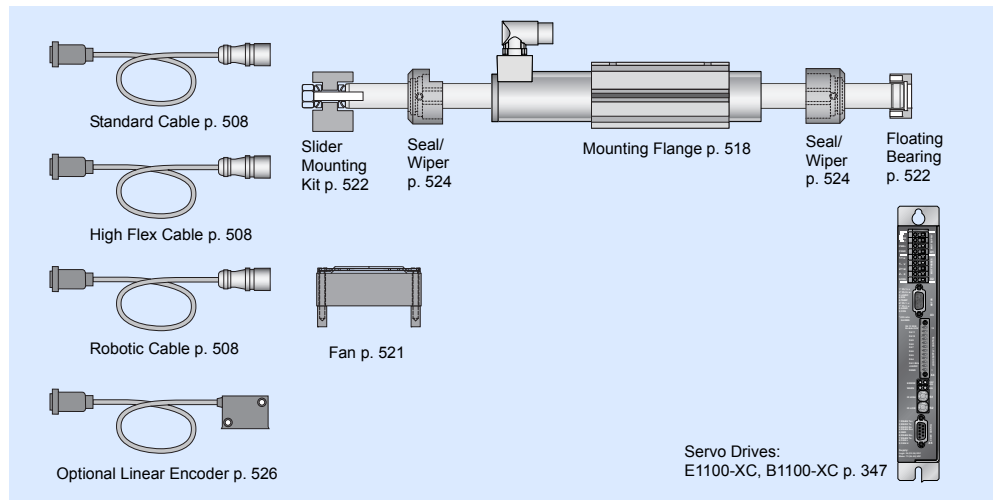

Max. Stroke: 840mm
Peak Force: 585N

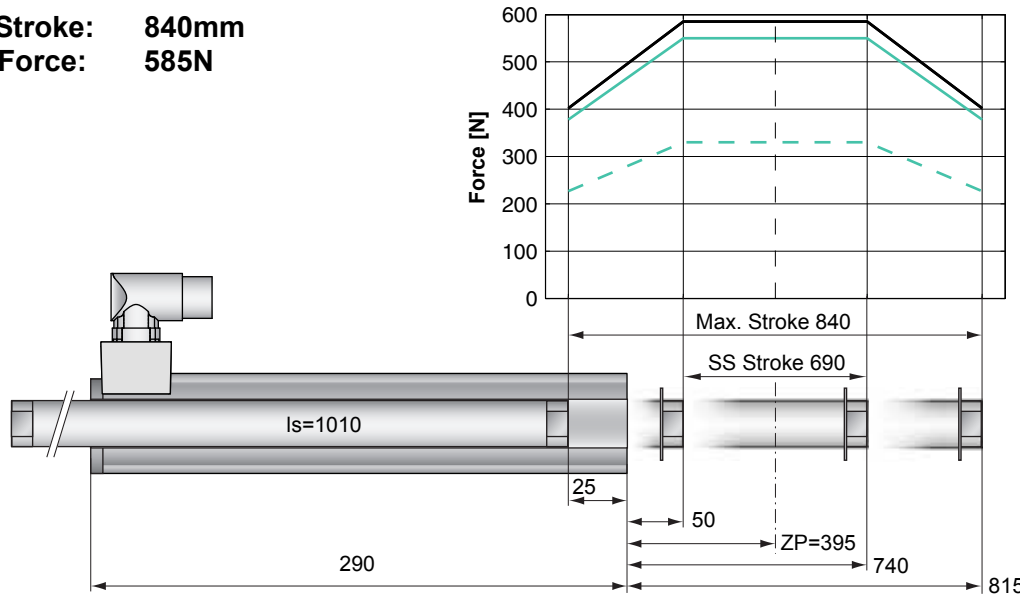

Dimensions in mm

Motor Specification

P01-		Standard Winding	Fast Winding
		48x240/690x840-C	48x240F/690x840-C
Extended Stroke ES	mm (in)	840 (33.07)	840 (33.07)
Standard Stroke SS	mm (in)	690 (27.17)	690 (27.17)
Peak Force E1100-XC	N (lbf)	585 (131.5)	550 (123.6)
Peak Force E1100-HC	N (lbf)	585 (131.5)	330 (74.2)
Cont. Force	N (lbf)	145 (32.5)	145 (32.6)
Cont. Force Fan cooling	N (lbf)	258 (58.0)	255 (57.3)
Border Force	%	69	69
Force Constant	N/A (lbf/A)	39.0 (8.77)	22.0 (4.95)
Max. Current @ 72VDC	A	15.0	26.0
Max. Current @ 48VDC	A	12.7	26.0
Max. Velocity @ 72VDC	m/s (in/s)	1.7 (67)	3.0 (119)
Max. Velocity @ 48VDC	m/s (in/s)	1.1 (45)	2.0 (79)
Phase Resist. 25/80 °C	Ohm	3.1/3.7	1.0/1.2
Phase Inductance	mH	3.1	1.0
Thermal Resistance	°K/W	1.1	1.1
Thermal Time Const.	sec	3000	3000
Stator Diameter	mm (in)	48 (1.89)	48 (1.89)
Stator Length	mm (in)	290 (11.40)	290 (11.40)
Stator Mass	g (lb)	1930 (4.25)	1930 (4.25)
Slider Diameter	mm (in)	28 (1.10)	28 (1.10)
Slider Length	mm (in)	1010 (39.76)	1010 (39.76)
Slider Mass	g (lb)	4540 (10.01)	4540 (10.01)
Position Repeatability	mm (in)	±0.05 (±0.0020)	±0.05 (±0.0020)
Linearity	%	±0.10	±0.10
Repeatability with EPS	mm (in)	±0.01 (±0.0004)	±0.01 (±0.0004)
Linearity with EPS	mm (in)	±0.01 (±0.0004)	±0.01 (±0.0004)

Position-Time Diagram

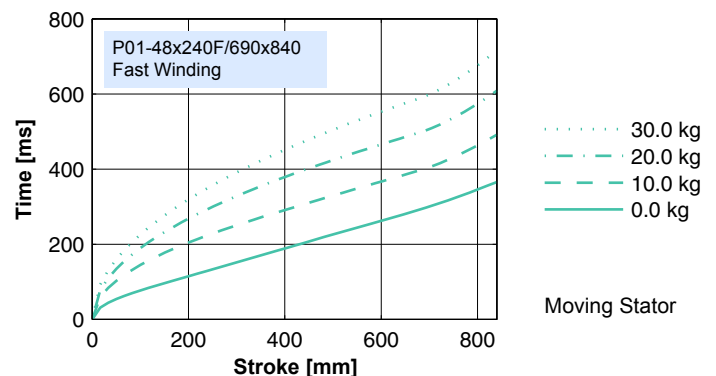
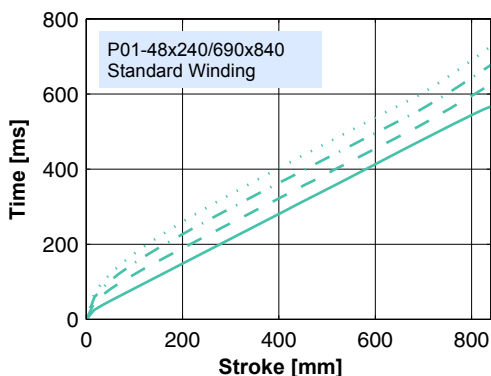

Connector Type

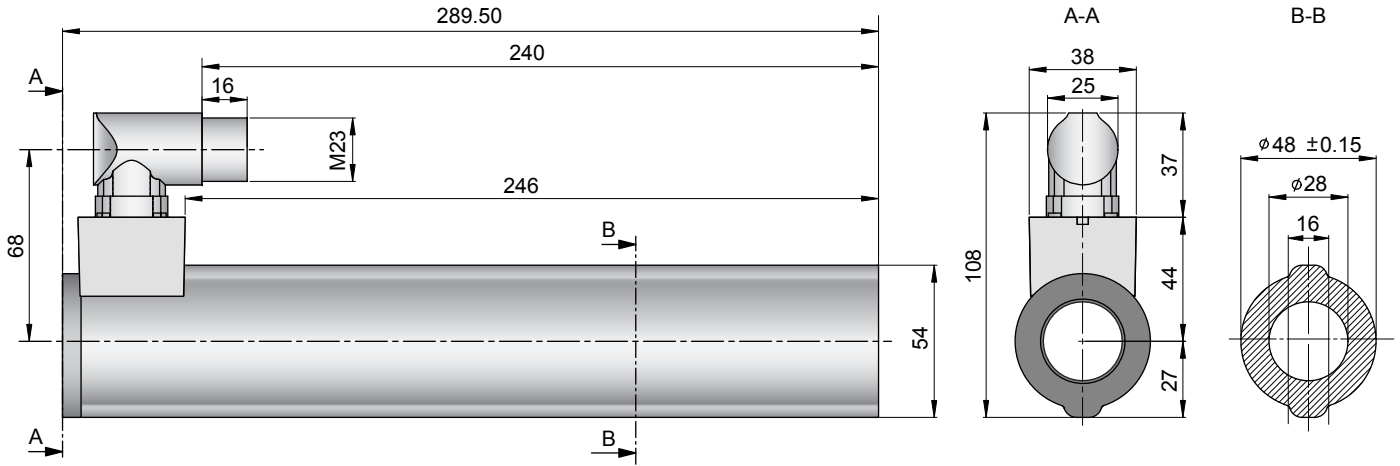

Linear Motor		Stator		Slider	
Type	Art.No	Type	Art. No.	Type	Art No.
P01-48x240/690x840-C	-->	PS01-48x240-C	0150-1219	& PL01-28x1010/930	0150-1387
P01-48x240F/690x840-C	-->	PS01-48x240F-C	0150-1220	& PL01-28x1010/930	0150-1387

Slider

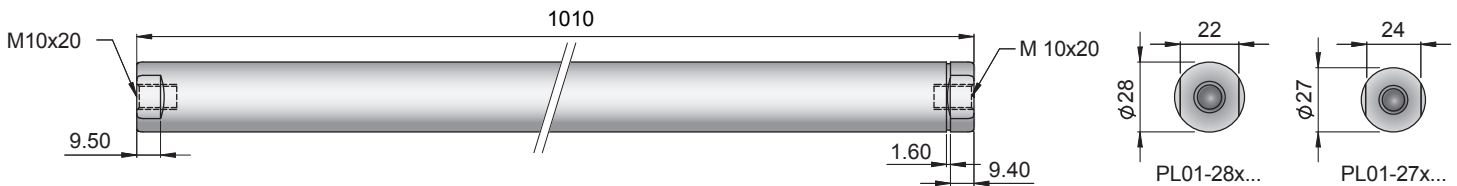

Standard Type	Slider Standard	PL01-28x1010/930	0150-1387
Special Sliders	Heavy Duty Slider with WC/C-Coating	PL02-28x1010/930	on request
	Hollow Slider hole diameter 8.5mm	PL01-28x1010/930-L	on request

Connectors

Motor Connector Wiring

		P01-48...-C
Ph 1+	red	A
Ph 1-	pink	B
Ph 2+	blue	C
Ph 2-	grey	D
+5VDC	white	E
GND	inner Shield	F
Sine	yellow	G
Cosine	green	H
Temp.	black	L
Shield	outer Shield	Case

Accessoires

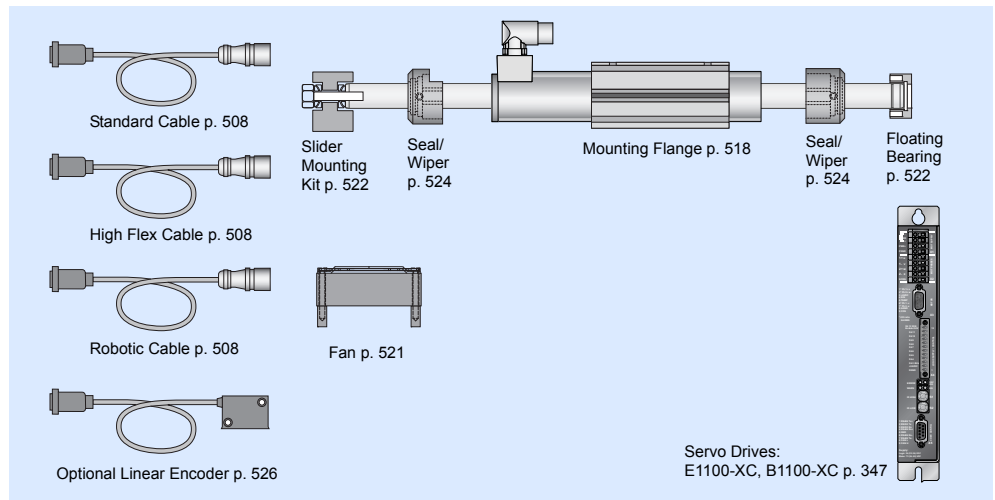

Max. Stroke: 1050mm
Peak Force: 585N

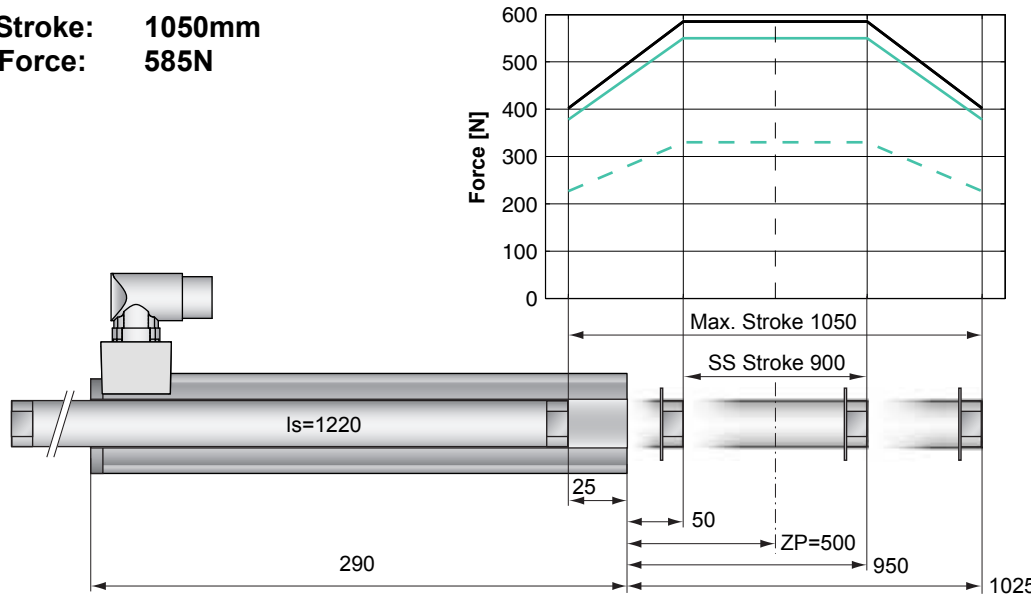

Dimensions in mm

Motor Specification

P01-		Standard Winding	Fast Winding
		48x240/900x1050-C	48x240F/900x1050-C
Extended Stroke ES	mm (in)	1050 (41.34)	1050 (41.34)
Standard Stroke SS	mm (in)	900 (35.43)	900 (35.43)
Peak Force E1100-XC	N (lbf)	585 (131.5)	550 (123.6)
Peak Force E1100-HC	N (lbf)	585 (131.5)	330 (74.2)
Cont. Force	N (lbf)	145 (32.5)	145 (32.6)
Cont. Force Fan cooling	N (lbf)	258 (58.0)	255 (57.3)
Border Force	%	69	69
Force Constant	N/A (lbf/A)	39.0 (8.77)	22.0 (4.95)
Max. Current @ 72VDC	A	15.0	26.0
Max. Current @ 48VDC	A	12.7	26.0
Max. Velocity @ 72VDC	m/s (in/s)	1.7 (67)	3.0 (119)
Max. Velocity @ 48VDC	m/s (in/s)	1.1 (45)	2.0 (79)
Phase Resist. 25/80 °C	Ohm	3.1/3.7	1.0/1.2
Phase Inductance	mH	3.1	1.0
Thermal Resistance	°K/W	1.1	1.1
Thermal Time Const.	sec	3000	3000
Stator Diameter	mm (in)	48 (1.89)	48 (1.89)
Stator Length	mm (in)	290 (11.40)	290 (11.40)
Stator Mass	g (lb)	1930 (4.25)	1930 (4.25)
Slider Diameter	mm (in)	28 (1.10)	28 (1.10)
Slider Length	mm (in)	1220 (48.03)	1220 (48.03)
Slider Mass	g (lb)	5510 (12.15)	5510 (12.15)
Position Repeatability	mm (in)	±0.05 (±0.0020)	±0.05 (±0.0020)
Linearity	%	±0.10	±0.10
Repeatability with EPS	mm (in)	±0.01 (±0.0004)	±0.01 (±0.0004)
Linearity with EPS	mm (in)	±0.01 (±0.0004)	±0.01 (±0.0004)

Position-Time Diagram

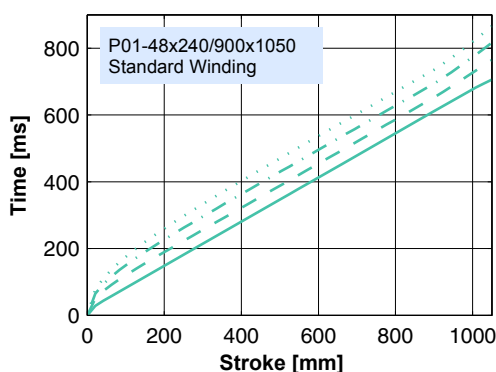

30.0 kg
 20.0 kg
 10.0 kg
 0.0 kg

Moving Stator

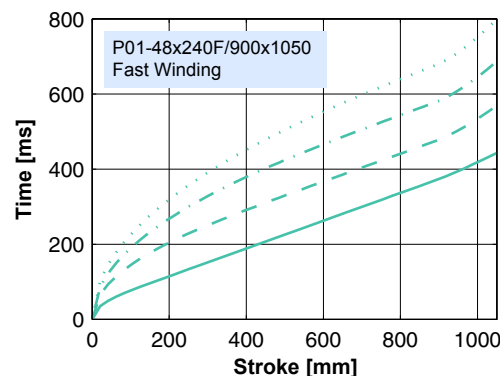

30.0 kg
 20.0 kg
 10.0 kg
 0.0 kg

Moving Stator

Connector Type

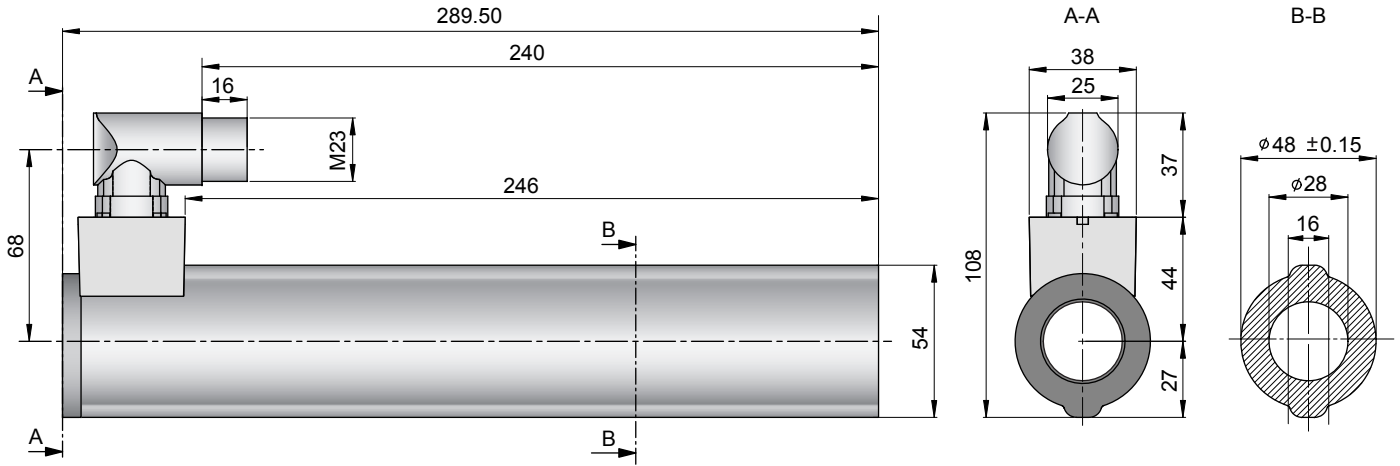

Linear Motor		Stator		Slider	
Type	Art.No	Type	Art. No.	Type	Art No.
P01-48x240/900x1050-C	-->	PS01-48x240-C	0150-1219	& PL01-28x1220/1140	0150-1388
P01-48x240F/900x1050-C	-->	PS01-48x240F-C	0150-1220	& PL01-28x1220/1140	0150-1388

Slider

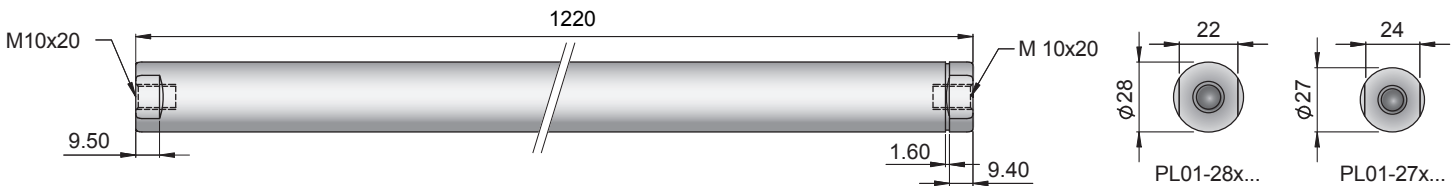

Standard Type	Slider Standard	PL01-28x1220/1140	0150-1388
Special Sliders	Heavy Duty Slider with WC/C-Coating	PL02-28x1220/1140	on request
	Hollow Slider hole diameter 8.5mm	PL01-28x1220/1140-L	on request

Connectors

Motor Connector Wiring

		P01-48...-C
Ph 1+	red	A
Ph 1-	pink	B
Ph 2+	blue	C
Ph 2-	grey	D
+5VDC	white	E
GND	inner Shield	F
Sine	yellow	G
Cosine	green	H
Temp.	black	L
Shield	outer Shield	Case

Accessoires

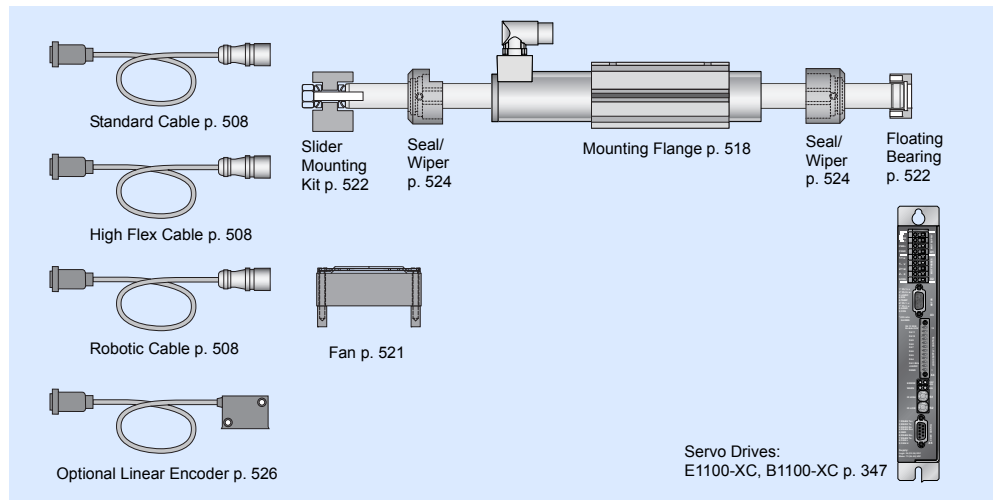

Max. Stroke: 1230mm
Peak Force: 585N

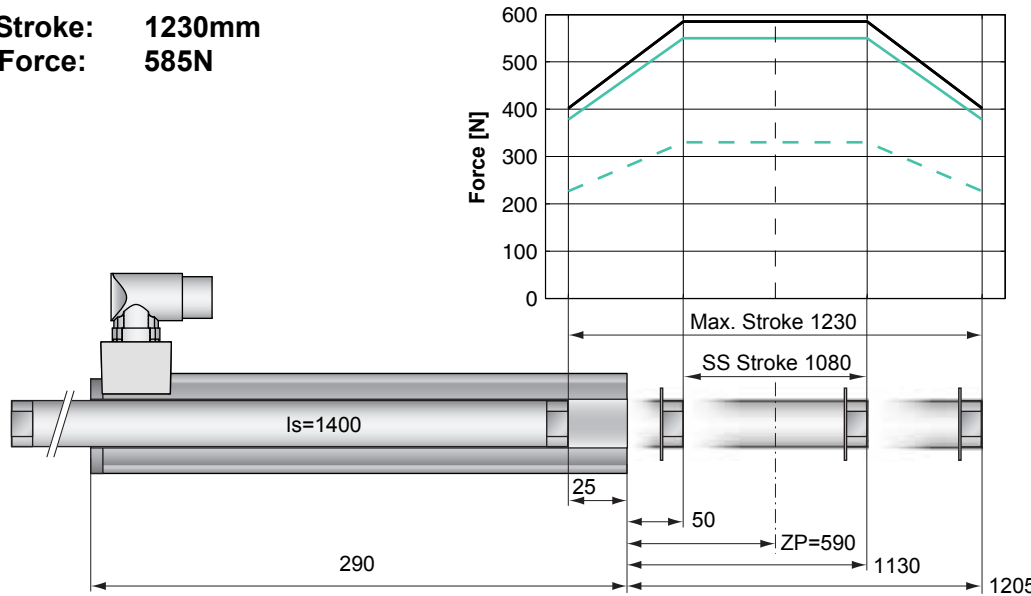

Dimensions in mm

Motor Specification

	P01-	Standard Winding	Fast Winding
		48x240/1080x1230-C	48x240F/1080x1230-C
Extended Stroke ES	mm (in)	1230 (48.43)	1230 (48.43)
Standard Stroke SS	mm (in)	1080 (42.52)	1080 (42.52)
Peak Force E1100-XC	N (lbf)	585 (131.5)	550 (123.6)
Peak Force E1100-HC	N (lbf)	585 (131.5)	330 (74.2)
Cont. Force	N (lbf)	145 (32.5)	145 (32.6)
Cont. Force Fan cooling	N (lbf)	258 (58.0)	255 (57.3)
Border Force	%	69	69
Force Constant	N/A (lbf/A)	39.0 (8.77)	22.0 (4.95)
Max. Current @ 72VDC	A	15.0	26.0
Max. Current @ 48VDC	A	12.7	26.0
Max. Velocity @ 72VDC	m/s (in/s)	1.7 (67)	3.0 (119)
Max. Velocity @ 48VDC	m/s (in/s)	1.1 (45)	2.0 (79)
Phase Resist. 25/80 °C	Ohm	3.1/3.7	1.0/1.2
Phase Inductance	mH	3.1	1.0
Thermal Resistance	°K/W	1.1	1.1
Thermal Time Const.	sec	3000	3000
Stator Diameter	mm (in)	48 (1.89)	48 (1.89)
Stator Length	mm (in)	290 (11.40)	290 (11.40)
Stator Mass	g (lb)	1930 (4.25)	1930 (4.25)
Slider Diameter	mm (in)	28 (1.10)	28 (1.10)
Slider Length	mm (in)	1400 (55.12)	1400 (55.12)
Slider Mass	g (lb)	6350 (14.00)	6350 (14.00)
Position Repeatability	mm (in)	±0.05 (±0.0020)	±0.05 (±0.0020)
Linearity	%	±0.10	±0.10
Repeatability with EPS	mm (in)	±0.01 (±0.0004)	±0.01 (±0.0004)
Linearity with EPS	mm (in)	±0.01 (±0.0004)	±0.01 (±0.0004)

Position-Time Diagram

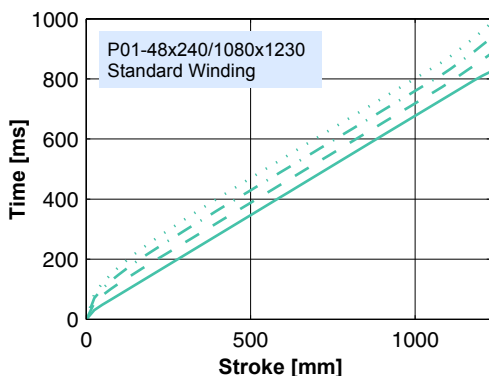

30.0 kg
 20.0 kg
 10.0 kg
 0.0 kg

Moving Stator

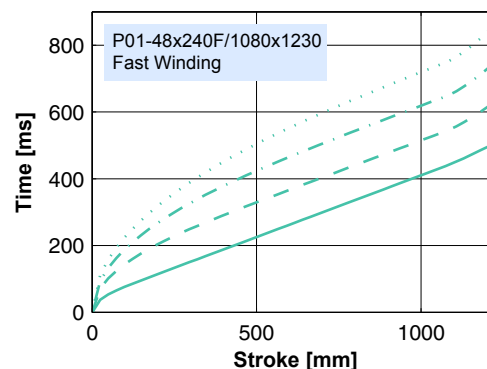

30.0 kg
 20.0 kg
 10.0 kg
 0.0 kg

Moving Stator

Connector Type

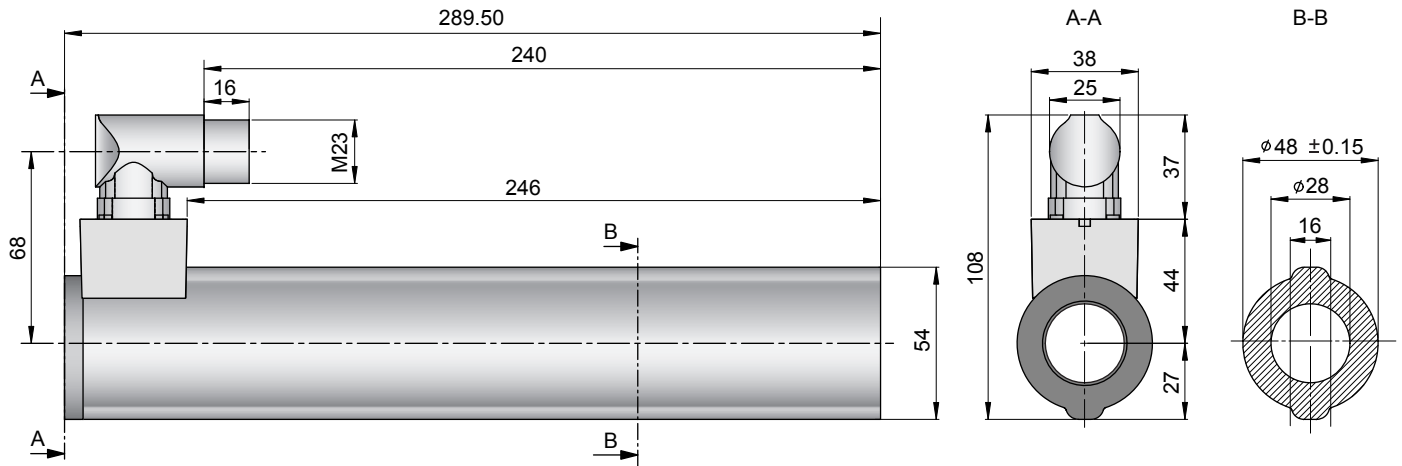

Linear Motor		Stator		Slider	
Type	Art.No	Type	Art. No.	Type	Art No.
P01-48x240/1080x1230-C	-->	PS01-48x240-C	0150-1219	& PL01-28x1400/1320	0150-1389
P01-48x240F/1080x1230-C	-->	PS01-48x240F-C	0150-1220	& PL01-28x1400/1320	0150-1389

Slider

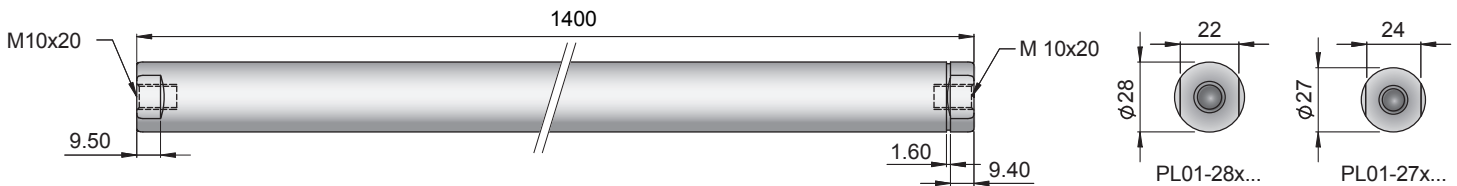

Standard Type	Slider Standard	PL01-28x1400/1320	0150-1389
Special Sliders	Heavy Duty Slider with WC/C-Coating	PL02-28x1400/1320	on request
	Hollow Slider hole diameter 8.5mm	PL01-28x1400/1320-L	on request

Connectors

Motor Connector Wiring

Motor Connector Wiring		P01-48...-C
Ph 1+	red	A
Ph 1-	pink	B
Ph 2+	blue	C
Ph 2-	grey	D
+5VDC	white	E
GND	inner Shield	F
Sine	yellow	G
Cosine	green	H
Temp.	black	L
Shield	outer Shield	Case

Accessoires

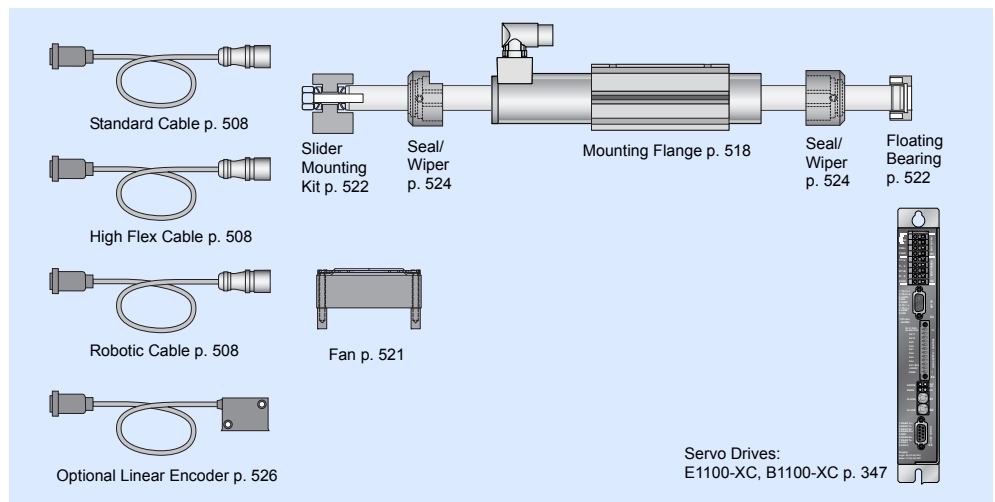

Max. Stroke: 1440mm
Peak Force: 585N

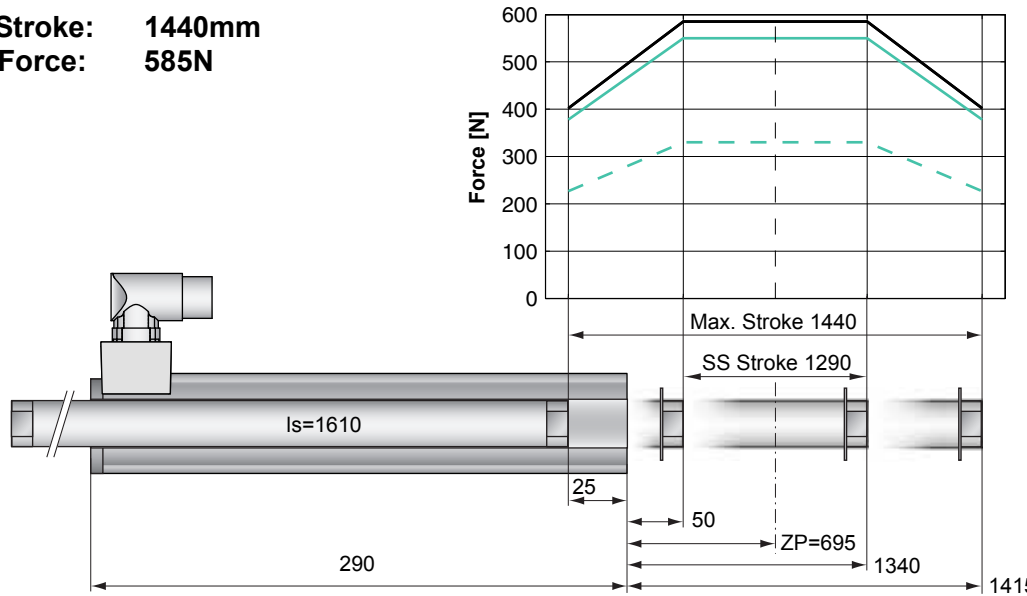

Dimensions in mm

Motor Specification

P01-	Standard Winding		Fast Winding	
	48x240/1290x1440-C		48x240F/1290x1440-C	
Extended Stroke ES	mm (in)	1440 (56.69)	1440 (56.69)	1440 (56.69)
Standard Stroke SS	mm (in)	1290 (50.79)	1290 (50.79)	1290 (50.79)
Peak Force E1100-XC	N (lbf)	585 (131.5)	550 (123.6)	550 (123.6)
Peak Force E1100-HC	N (lbf)	585 (131.5)	330 (74.2)	330 (74.2)
Cont. Force	N (lbf)	145 (32.5)	145 (32.6)	145 (32.6)
Cont. Force Fan cooling	N (lbf)	258 (58.0)	255 (57.3)	255 (57.3)
Border Force	%	69	69	69
Force Constant	N/A (lbf/A)	39.0 (8.77)	22.0 (4.95)	22.0 (4.95)
Max. Current @ 72VDC	A	15.0	26.0	26.0
Max. Current @ 48VDC	A	12.7	26.0	26.0
Max. Velocity @ 72VDC	m/s (in/s)	1.7 (67)	3.0 (119)	3.0 (119)
Max. Velocity @ 48VDC	m/s (in/s)	1.1 (45)	2.0 (79)	2.0 (79)
Phase Resist. 25/80 °C	Ohm	3.1/3.7	1.0/1.2	1.0/1.2
Phase Inductance	mH	3.1	1.0	1.0
Thermal Resistance	°K/W	1.1	1.1	1.1
Thermal Time Const.	sec	3000	3000	3000
Stator Diameter	mm (in)	48 (1.89)	48 (1.89)	48 (1.89)
Stator Length	mm (in)	290 (11.40)	290 (11.40)	290 (11.40)
Stator Mass	g (lb)	1930 (4.25)	1930 (4.25)	1930 (4.25)
Slider Diameter	mm (in)	28 (1.10)	28 (1.10)	28 (1.10)
Slider Length	mm (in)	1610 (63.39)	1610 (63.39)	1610 (63.39)
Slider Mass	g (lb)	7330 (16.16)	7330 (16.16)	7330 (16.16)
Position Repeatability	mm (in)	±0.05 (±0.0020)	±0.05 (±0.0020)	±0.05 (±0.0020)
Linearity	%	±0.10	±0.10	±0.10
Repeatability with EPS	mm (in)	±0.01 (±0.0004)	±0.01 (±0.0004)	±0.01 (±0.0004)
Linearity with EPS	mm (in)	±0.01 (±0.0004)	±0.01 (±0.0004)	±0.01 (±0.0004)

Position-Time Diagram

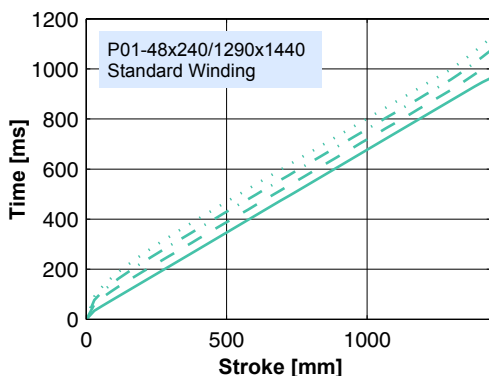

30.0 kg
 20.0 kg
 10.0 kg
 0.0 kg

Moving Stator

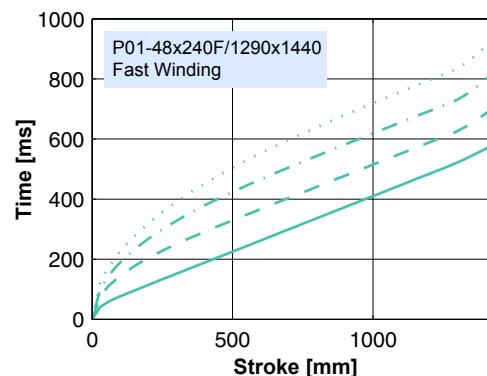

30.0 kg
 20.0 kg
 10.0 kg
 0.0 kg

Moving Stator

Connector Type

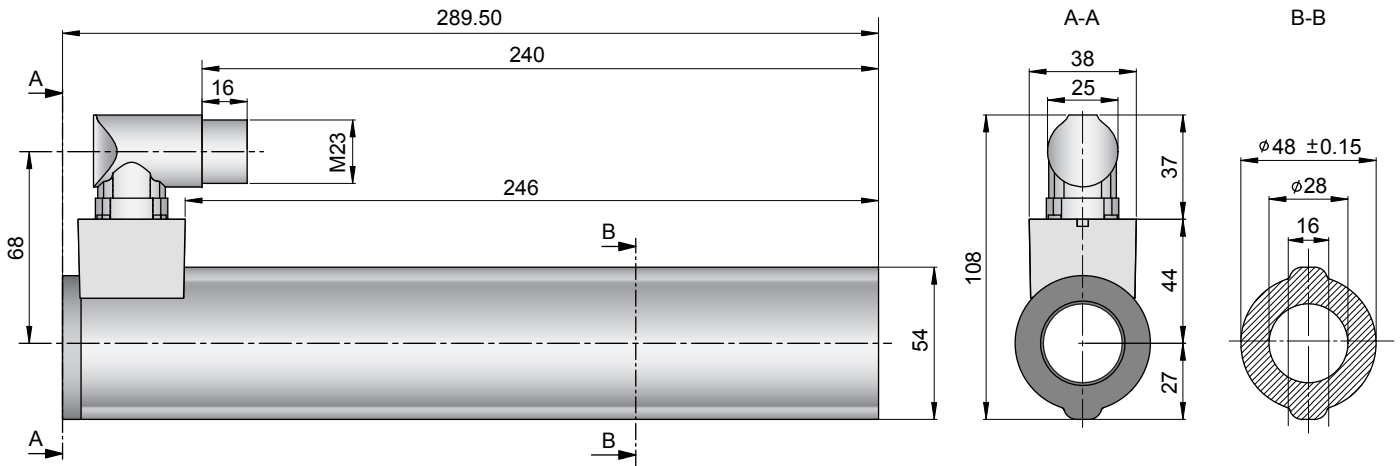

Linear Motor		Stator		Slider	
Type	Art.No	Type	Art. No.	Type	Art No.
P01-48x240/1290x1440-C	-->	PS01-48x240-C	0150-1219	& PL01-28x1610/1530	0150-1390
P01-48x240F/1290x1440-C	-->	PS01-48x240F-C	0150-1220	& PL01-28x1610/1530	0150-1390

Slider

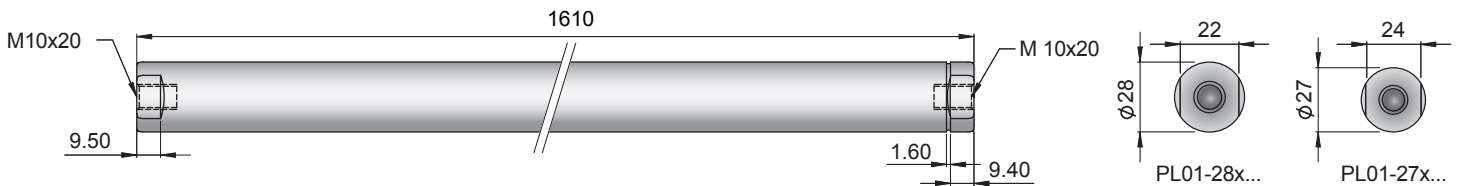

Standard Type	Slider Standard	PL01-28x1610/1530	0150-1390
Special Sliders	Heavy Duty Slider with WC/C-Coating	PL02-28x1610/1530	on request
	Hollow Slider hole diameter 8.5mm	PL01-28x1610/1530-L	on request

Connectors

Motor Connector Wiring

		P01-48...-C
Ph 1+	red	A
Ph 1-	pink	B
Ph 2+	blue	C
Ph 2-	grey	D
+5VDC	white	E
GND	inner Shield	F
Sine	yellow	G
Cosine	green	H
Temp.	black	L
Shield	outer Shield	Case

Accessoires

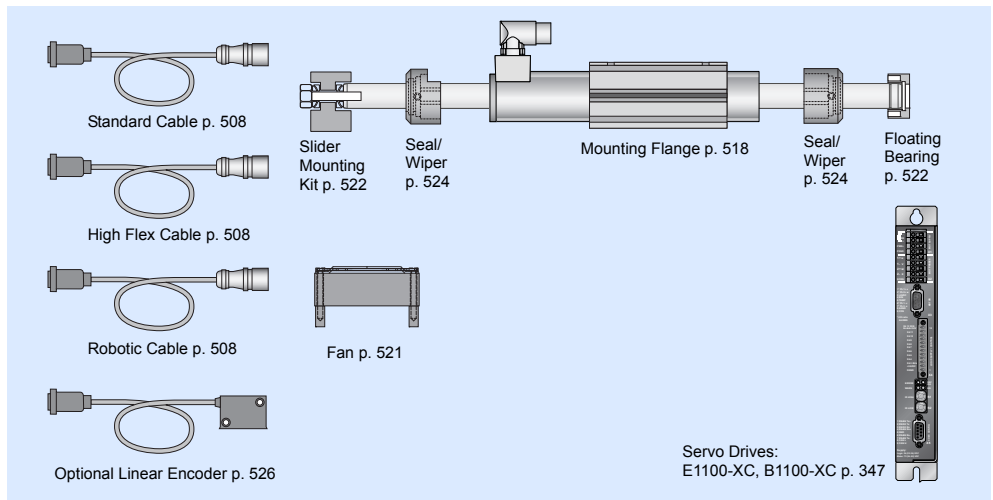

Max. Stroke: 1650mm
Peak Force: 585N

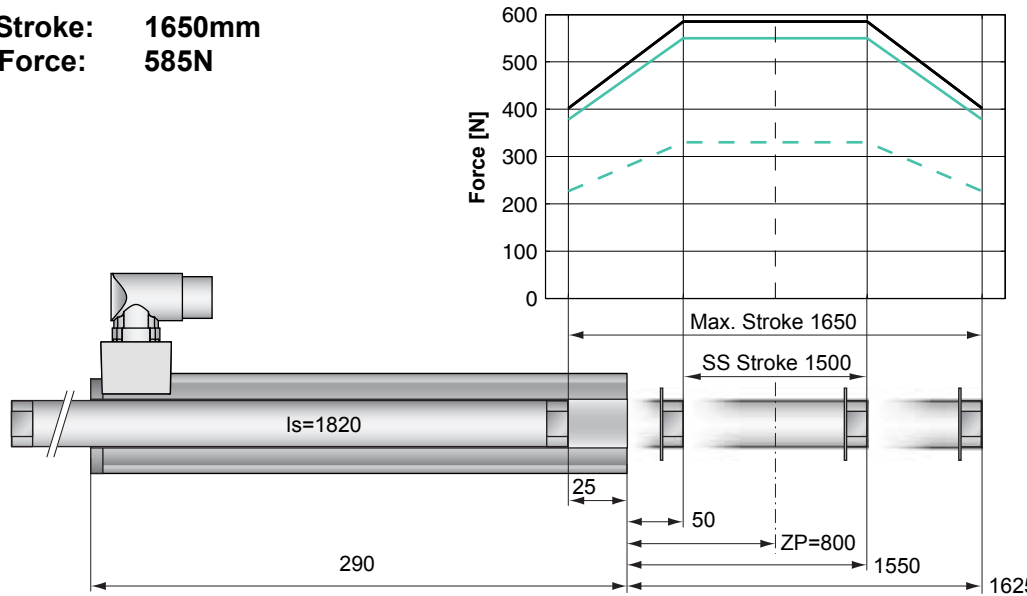

Dimensions in mm

Motor Specification

P01-	Standard Winding		Fast Winding	
	48x240/1500x1650-C		48x240F/1500x1650-C	
Extended Stroke ES	mm (in)	1650 (64.96)	1650 (64.96)	1650 (64.96)
Standard Stroke SS	mm (in)	1500 (59.06)	1500 (59.06)	1500 (59.06)
Peak Force E1100-XC	N (lbf)	585 (131.5)	550 (123.6)	550 (123.6)
Peak Force E1100-HC	N (lbf)	585 (131.5)	330 (74.2)	330 (74.2)
Cont. Force	N (lbf)	145 (32.5)	145 (32.6)	145 (32.6)
Cont. Force Fan cooling	N (lbf)	258 (58.0)	255 (57.3)	255 (57.3)
Border Force	%	69	69	69
Force Constant	N/A (lbf/A)	39.0 (8.77)	22.0 (4.95)	22.0 (4.95)
Max. Current @ 72VDC	A	15.0	26.0	26.0
Max. Current @ 48VDC	A	12.7	26.0	26.0
Max. Velocity @ 72VDC	m/s (in/s)	1.7 (67)	3.0 (119)	3.0 (119)
Max. Velocity @ 48VDC	m/s (in/s)	1.1 (45)	2.0 (79)	2.0 (79)
Phase Resist. 25/80 °C	Ohm	3.1/3.7	1.0/1.2	1.0/1.2
Phase Inductance	mH	3.1	1.0	1.0
Thermal Resistance	°K/W	1.1	1.1	1.1
Thermal Time Const.	sec	3000	3000	3000
Stator Diameter	mm (in)	48 (1.89)	48 (1.89)	48 (1.89)
Stator Length	mm (in)	290 (11.40)	290 (11.40)	290 (11.40)
Stator Mass	g (lb)	1930 (4.25)	1930 (4.25)	1930 (4.25)
Slider Diameter	mm (in)	28 (1.10)	28 (1.10)	28 (1.10)
Slider Length	mm (in)	1820 (71.65)	1820 (71.65)	1820 (71.65)
Slider Mass	g (lb)	8300 (18.30)	8300 (18.30)	8300 (18.30)
Position Repeatability	mm (in)	±0.05 (±0.0020)	±0.05 (±0.0020)	±0.05 (±0.0020)
Linearity	%	±0.10	±0.10	±0.10
Repeatability with EPS	mm (in)	±0.01 (±0.0004)	±0.01 (±0.0004)	±0.01 (±0.0004)
Linearity with EPS	mm (in)	±0.01 (±0.0004)	±0.01 (±0.0004)	±0.01 (±0.0004)

Position-Time Diagram

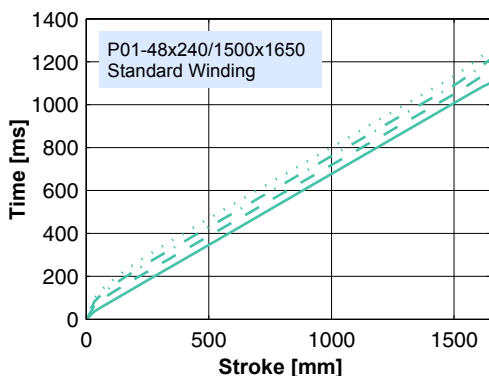

30.0 kg
 20.0 kg
 10.0 kg
 0.0 kg

Moving Stator

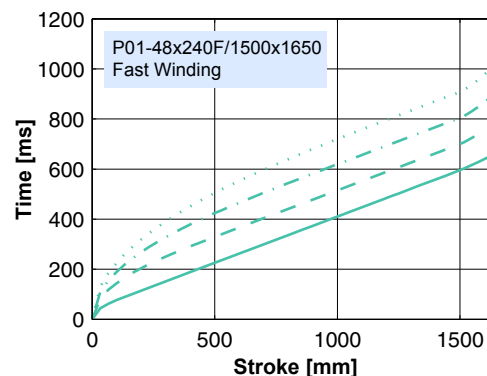

30.0 kg
 20.0 kg
 10.0 kg
 0.0 kg

Moving Stator

Connector Type

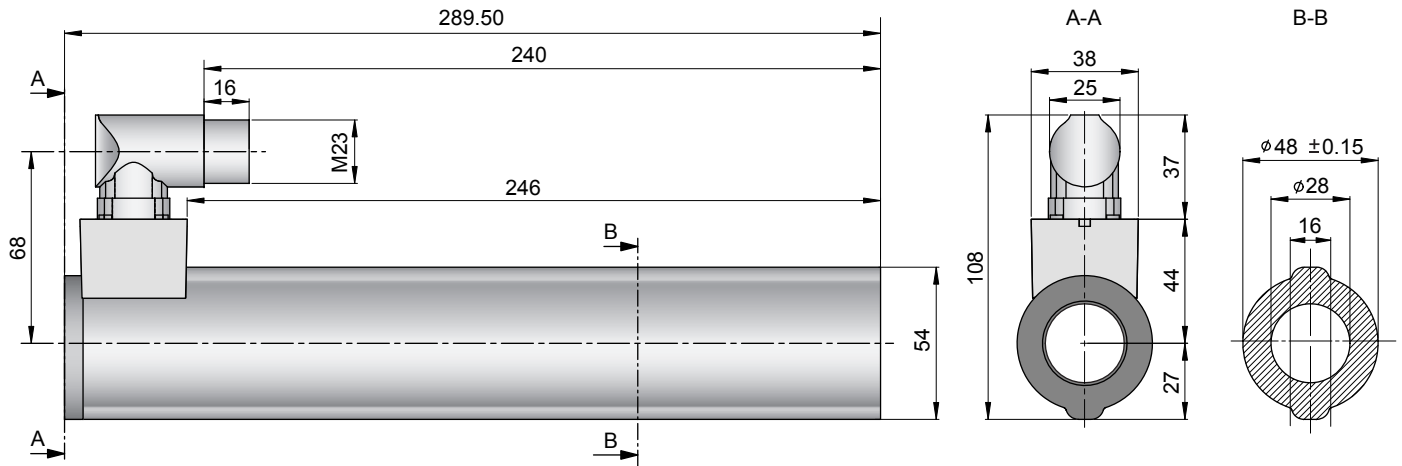

Linear Motor		Stator		Slider	
Type	Art. No.	Type	Art. No.	Type	Art. No.
P01-48x240/1500x1650-C	-->	PS01-48x240-C	0150-1219	& PL01-28x1820/1740	0150-1395
P01-48x240F/1500x1650-C	-->	PS01-48x240F-C	0150-1220	& PL01-28x1820/1740	0150-1395

Slider

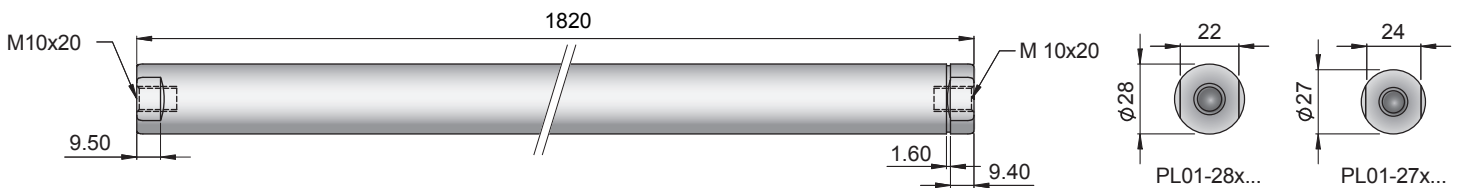

Standard Type	Slider Standard	PL01-28x1820/1740	0150-1395
Special Sliders	Heavy Duty Slider with WC/C-Coating	PL02-28x1820/1740	on request
	Hollow Slider hole diameter 8.5mm	PL01-28x1820/1740-L	on request

Connectors

Motor Connector Wiring

		P01-48...-C
Ph 1+	red	A
Ph 1-	pink	B
Ph 2+	blue	C
Ph 2-	grey	D
+5VDC	white	E
GND	inner Shield	F
Sine	yellow	G
Cosine	green	H
Temp.	black	L
Shield	outer Shield	Case

Accessoires

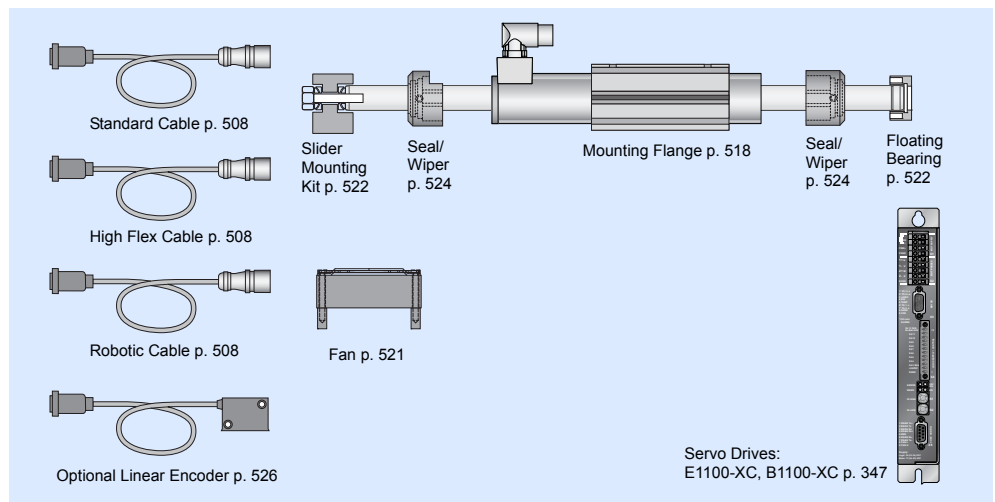

Max. Stroke: 1830mm
Peak Force: 585N

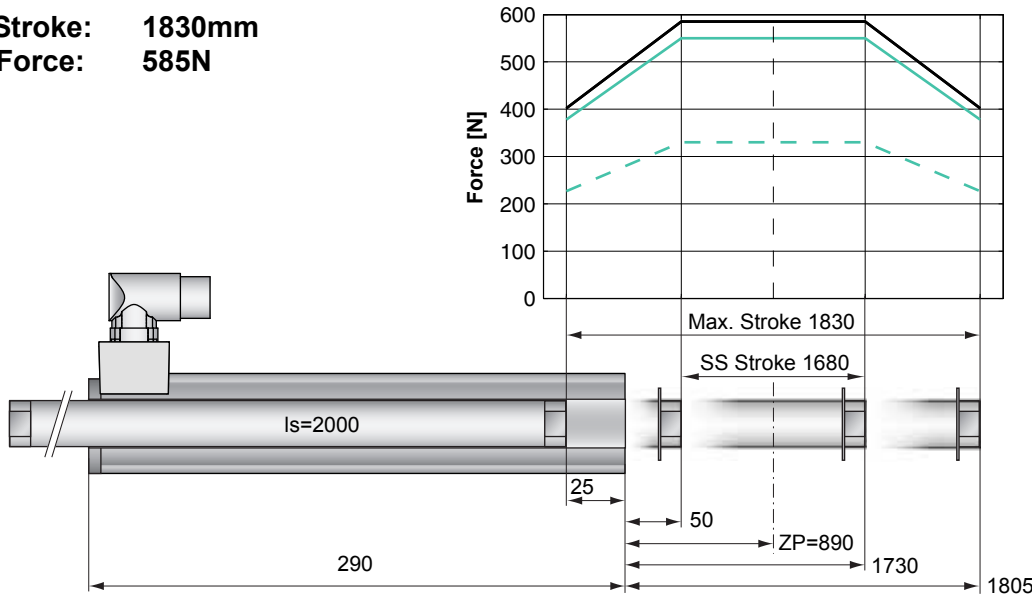

Dimensions in mm

Motor Specification

	P01-	Standard Winding	Fast Winding
		48x240/1680x1830-C	48x240F/1680x1830-C
Extended Stroke ES	mm (in)	1830 (72.05)	1830 (72.05)
Standard Stroke SS	mm (in)	1680 (66.14)	1680 (66.14)
Peak Force E1100-XC	N (lbf)	585 (131.5)	550 (123.6)
Peak Force E1100-HC	N (lbf)	585 (131.5)	330 (74.2)
Cont. Force	N (lbf)	145 (32.5)	145 (32.6)
Cont. Force Fan cooling	N (lbf)	258 (58.0)	255 (57.3)
Border Force	%	69	69
Force Constant	N/A (lbf/A)	39.0 (8.77)	22.0 (4.95)
Max. Current @ 72VDC	A	15.0	26.0
Max. Current @ 48VDC	A	12.7	26.0
Max. Velocity @ 72VDC	m/s (in/s)	1.7 (67)	3.0 (119)
Max. Velocity @ 48VDC	m/s (in/s)	1.1 (45)	2.0 (79)
Phase Resist. 25/80 °C	Ohm	3.1/3.7	1.0/1.2
Phase Inductance	mH	3.1	1.0
Thermal Resistance	°K/W	1.1	1.1
Thermal Time Const.	sec	3000	3000
Stator Diameter	mm (in)	48 (1.89)	48 (1.89)
Stator Length	mm (in)	290 (11.40)	290 (11.40)
Stator Mass	g (lb)	1930 (4.25)	1930 (4.25)
Slider Diameter	mm (in)	28 (1.10)	28 (1.10)
Slider Length	mm (in)	2000 (78.74)	2000 (78.74)
Slider Mass	g (lb)	9140 (20.15)	9140 (20.15)
Position Repeatability	mm (in)	±0.05 (±0.0020)	±0.05 (±0.0020)
Linearity	%	±0.10	±0.10
Repeatability with EPS	mm (in)	±0.01 (±0.0004)	±0.01 (±0.0004)
Linearity with EPS	mm (in)	±0.01 (±0.0004)	±0.01 (±0.0004)

Position-Time Diagram

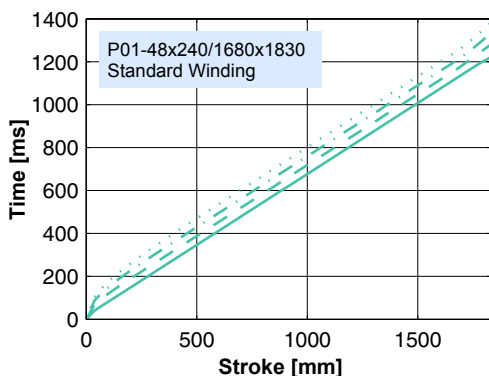

30.0 kg
 20.0 kg
 10.0 kg
 0.0 kg

Moving Stator

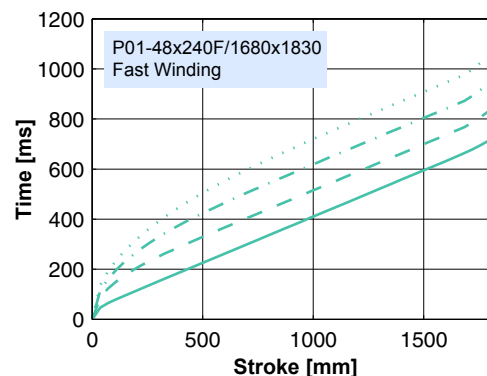

30.0 kg
 20.0 kg
 10.0 kg
 0.0 kg

Moving Stator

Connector Type

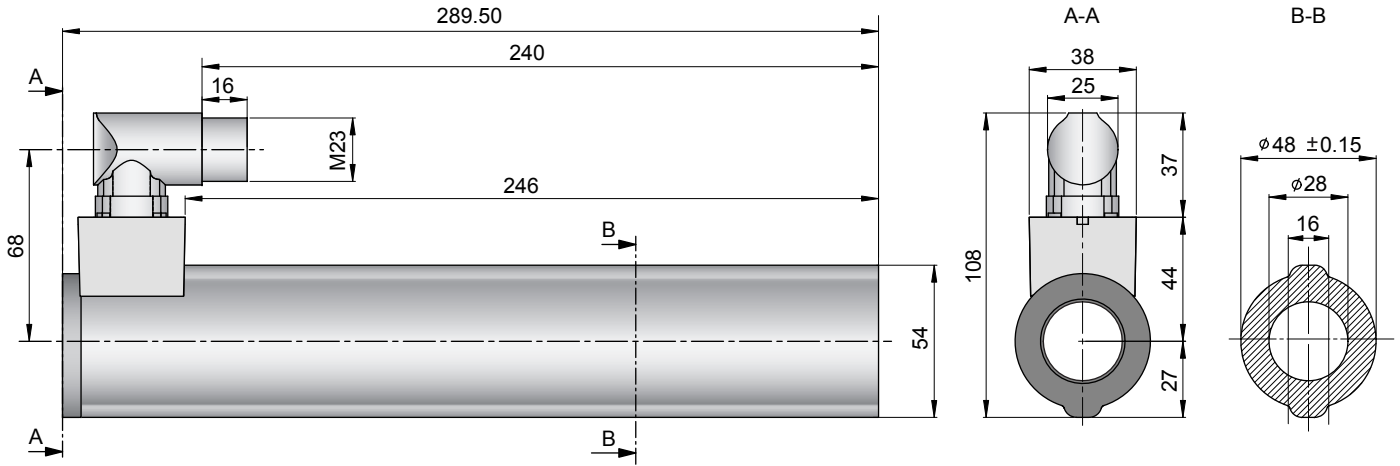

Linear Motor		Stator		Slider	
Type	Art. No.	Type	Art. No.	Type	Art. No.
P01-48x240/1680x1830-C	-->	PS01-48x240-C	0150-1219	& PL01-28x2000/1920	0150-1396
P01-48x240F/1680x1830-C	-->	PS01-48x240F-C	0150-1220	& PL01-28x2000/1920	0150-1396

Slider

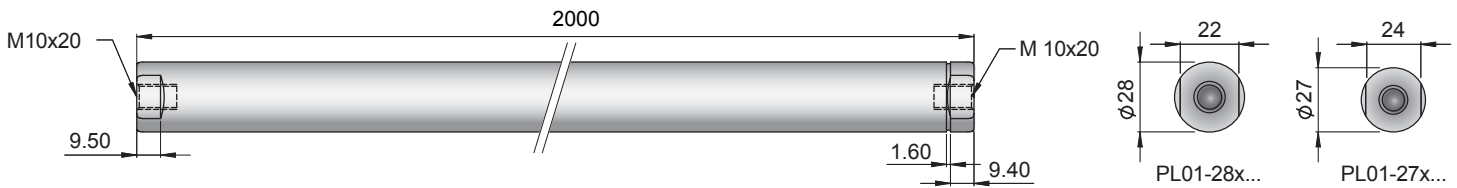

Standard Type	Slider Standard	PL01-28x2000/1920	0150-1396
Special Sliders	Heavy Duty Slider with WC/C-Coating	PL02-28x2000/1920	on request
	Hollow Slider hole diameter 8.5mm	PL01-28x2000/1920-L	on request

Connectors

Motor Connector Wiring

		P01-48...-C
Ph 1+	red	A
Ph 1-	pink	B
Ph 2+	blue	C
Ph 2-	grey	D
+5VDC	white	E
GND	inner Shield	F
Sine	yellow	G
Cosine	green	H
Temp.	black	L
Shield	outer Shield	Case

Accessoires

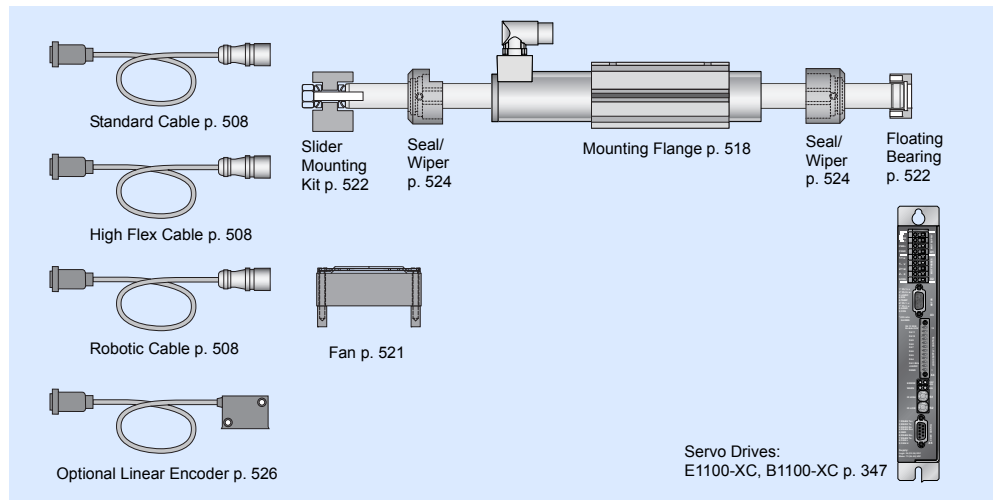



P01-48x360F/60x210 166

P01-48x360F/180x330 168

P01-48x360F/270x420 170

P01-48x360F/360x510 172

P01-48x360F/480x630 174

P01-48x360F/570x720 176

P01-48x360F/780x930 178

P01-48x360F/960x1110 180

P01-48x360F/1170x1320 182

P01-48x360F/1380x1530 184

P01-48x360F/1560x1710 186

Max. Stroke: 210mm
Max. Force: 1024N

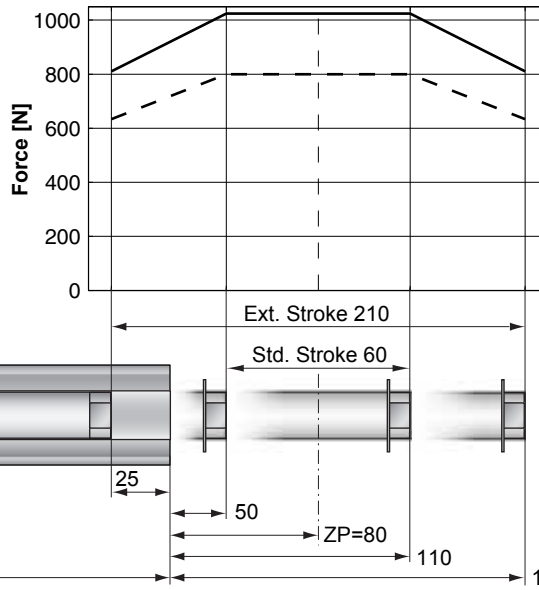

— E1250-UC, 72VDC
 - - - E1100-XC, 72VDC

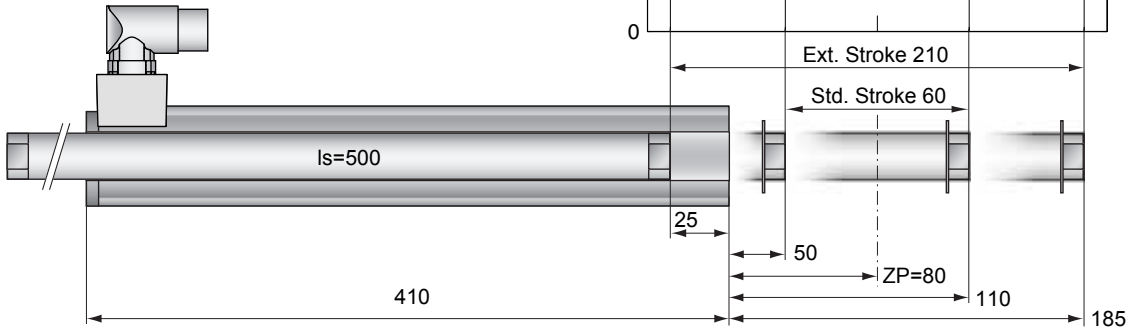

Dimensions in mm

Motor Specification

		F-Winding	
		48x360F/60x210-C	
Extended Stroke	mm (in)	210 (8.27)	
Standard Stroke	mm (in)	60 (2.36)	
Max. Force E1250-UC	N (lbf)	1024 (230.1)	
Max. Force E1100-XC	N (lbf)	800 (179.8)	
Cont. Force	N (lbf)	203 (45.7)	
Cont. Force with fan	N (lbf)	354 (79.7)	
Border Force	%	79	
Force Constant	N/A (lbf/A)	32.0 (7.19)	
Max. Current @ 72VDC	A	32.0	
Max. Velocity @ 72VDC	m/s (in/s)	2.1 (82)	
Phase Resist. 25/80 °C	Ohm	1.38/1.67	
Phase Inductance	mH	1.6	
Thermal Resistance	°K/W	0.8	
Thermal Time Const.	sec	3200	
Stator Diameter	mm (in)	48 (1.89)	
Stator Length	mm (in)	410 (16.12)	
Stator Mass	g (lb)	2880 (6.35)	
Slider Diameter	mm (in)	28 (1.10)	
Slider Length	mm (in)	500 (19.69)	
Slider Mass	g (lb)	2160 (4.76)	
Position Repeatability	mm (in)	±0.05 (±0.0020)	
Linearity	%	±0.25	
Repeatability with EPS	mm (in)	±0.01 (±0.0004)	
Linearity with EPS	mm (in)	±0.01 (±0.0004)	

Position-Time Diagram

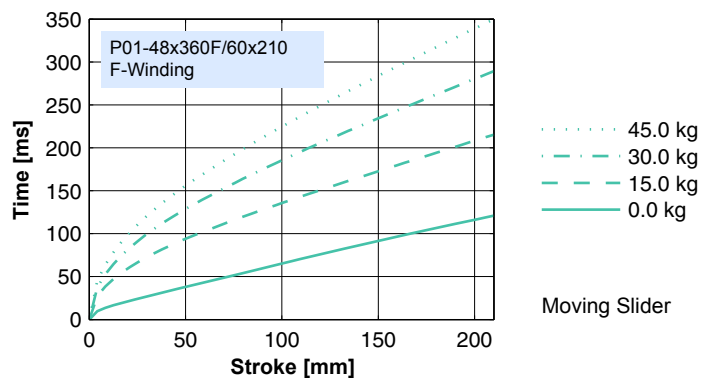

Moving Slider

Connector Type

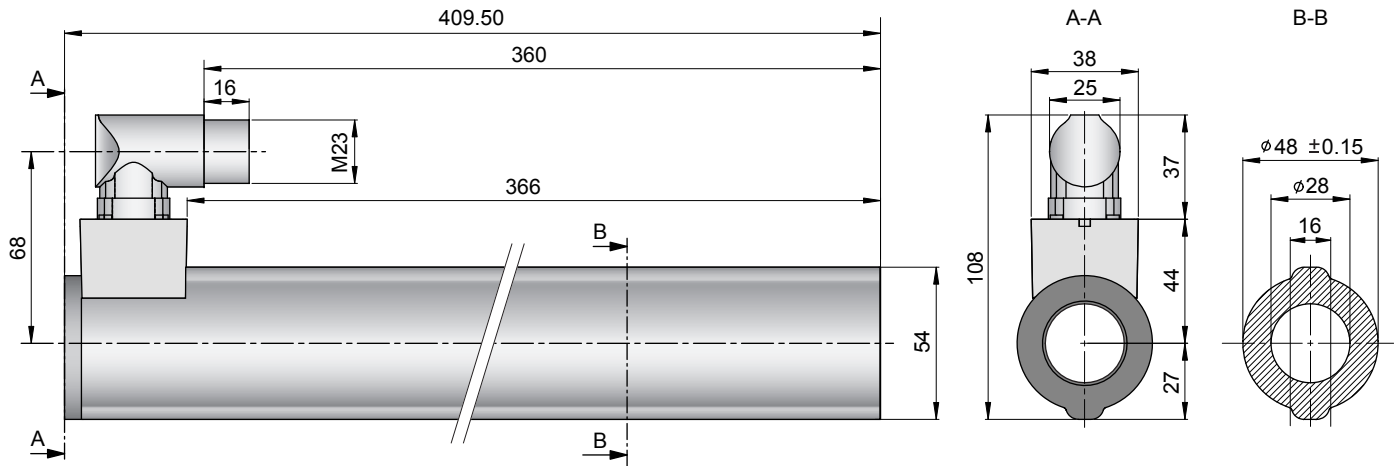

Linear Motor		Stator		Slider	
Type	Art.No	Type	Art. No.	Type	Art. No.
P01-48x360F/60x210-C	-->	PS01-48x360F-C	0150-1269	& PL01-28x500/420	0150-1382

Slider

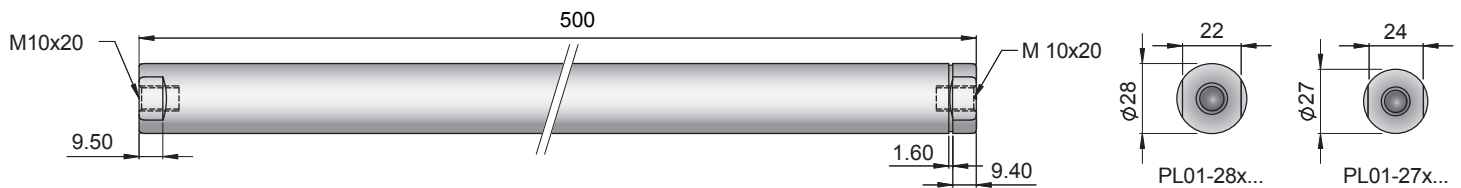

Standard Type	Slider Standard	PL01-28x500/420	0150-1382
Special Sliders	Heavy Duty Slider with WC/C-Coating	PL02-28x500/420	0150-1413
	Hollow Slider hole diameter 6mm	PL01-28x500/420-L	0150-1480
	High Clearance Slider d=27mm	PL01-27x500/420	on request

Connectors

Motor connector Wiring

		P01-48...-C
Ph 1+	Red	A
Ph 1-	Pink	B
Ph 2+	Blue	C
Ph 2-	Grey	D
+5VDC	White	E
GND	Inner Shield	F
Sine	Yellow	G
Cosine	Green	H
Temp.	Black	L
Shield	Outer Shield	Case

Accessoires

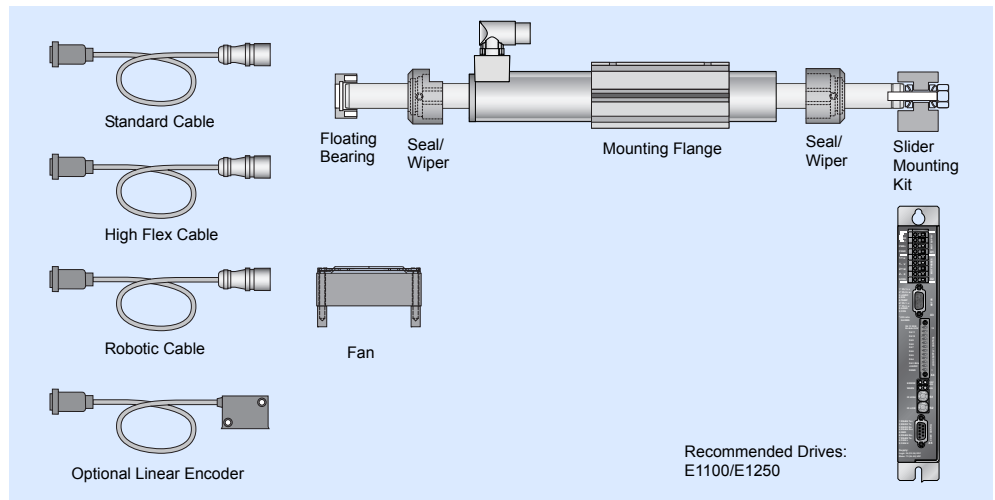

Recommended Drives:
E1100/E1250

Max. Stroke: 330mm
Max. Force: 1024N

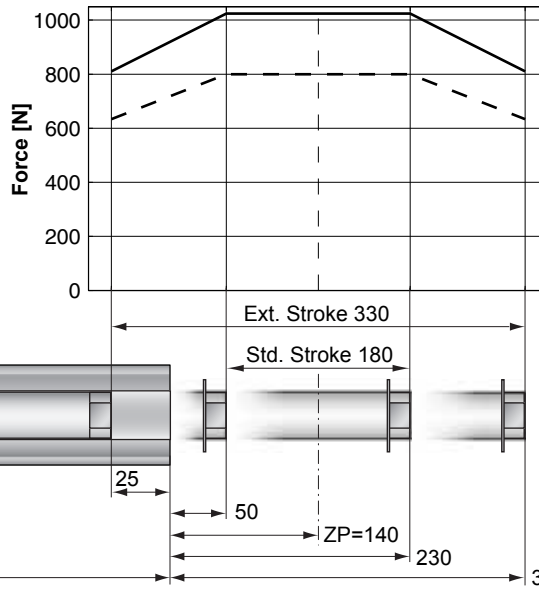

— E1250-UC, 72VDC
 - - - E1100-XC, 72VDC

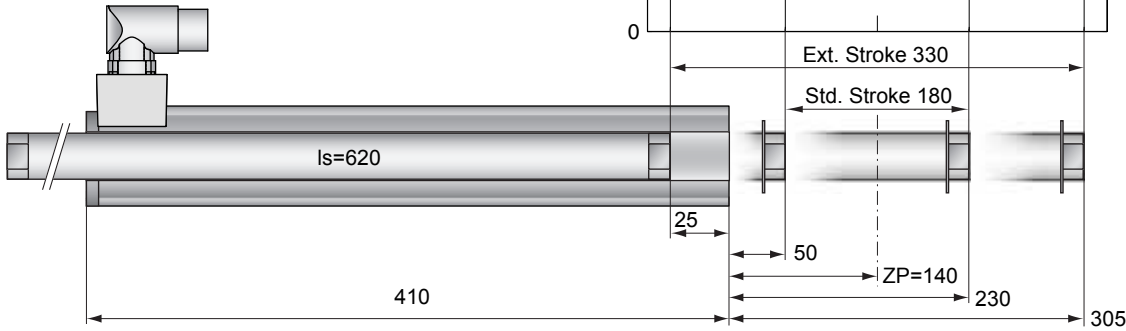

Dimensions in mm

Motor Specification

		F-Winding	
		48x360F/180x330-C	
Extended Stroke	mm (in)	330 (12.99)	
Standard Stroke	mm (in)	180 (7.09)	
Max. Force E1250-UC	N (lbf)	1024 (230.1)	
Max. Force E1100-XC	N (lbf)	800 (179.8)	
Cont. Force	N (lbf)	203 (45.7)	
Cont. Force with fan	N (lbf)	354 (79.7)	
Border Force	%	79	
Force Constant	N/A (lbf/A)	32.0 (7.19)	
Max. Current @ 72VDC	A	32.0	
Max. Velocity @ 72VDC	m/s (in/s)	2.1 (82)	
Phase Resist. 25/80 °C	Ohm	1.38/1.67	
Phase Inductance	mH	1.6	
Thermal Resistance	°K/W	0.8	
Thermal Time Const.	sec	3200	
Stator Diameter	mm (in)	48 (1.89)	
Stator Length	mm (in)	410 (16.12)	
Stator Mass	g (lb)	2880 (6.35)	
Slider Diameter	mm (in)	28 (1.10)	
Slider Length	mm (in)	620 (24.41)	
Slider Mass	g (lb)	2720 (6.00)	
Position Repeatability	mm (in)	±0.05 (±0.0020)	
Linearity	%	±0.20	
Repeatability with EPS	mm (in)	±0.01 (±0.0004)	
Linearity with EPS	mm (in)	±0.01 (±0.0004)	

Position-Time Diagram

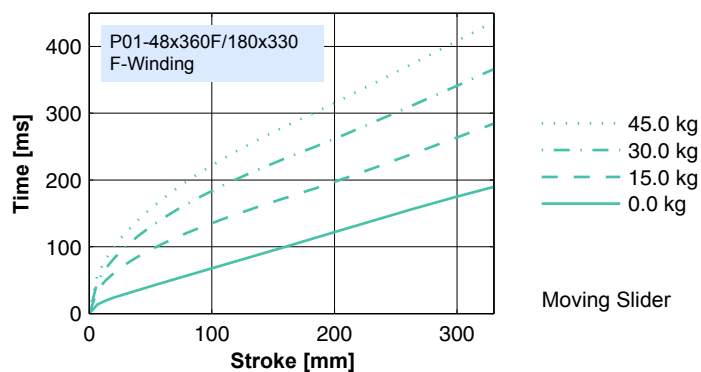

Moving Slider

Connector Type

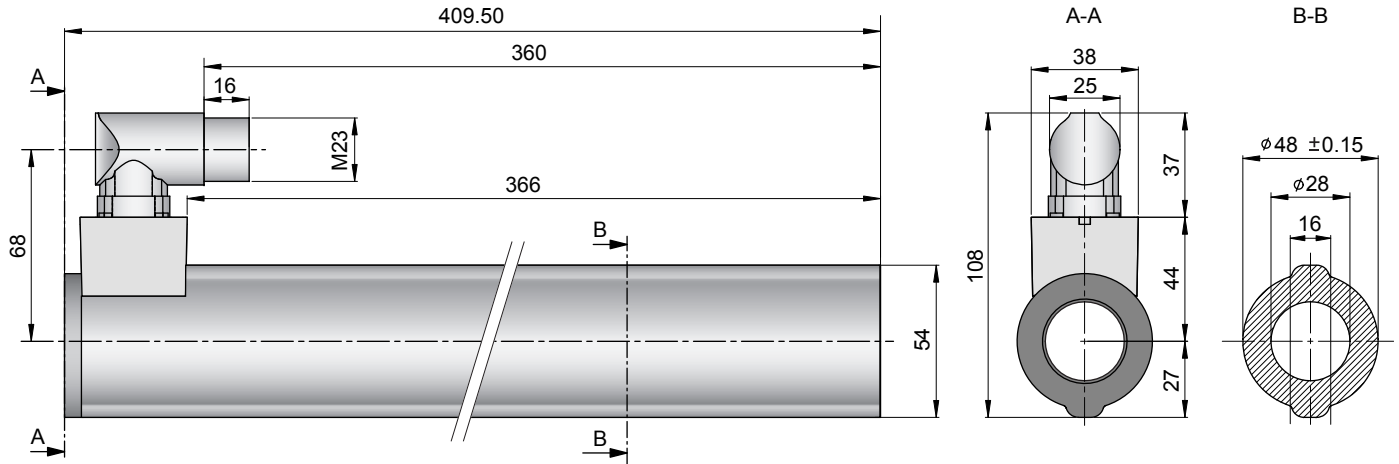

Linear Motor		Stator		Slider	
Type	Art.No	Type	Art. No.	Type	Art. No.
P01-48x360F/180x330-C	-->	PS01-48x360F-C	0150-1269	& PL01-28x620/540	0150-1383

Slider

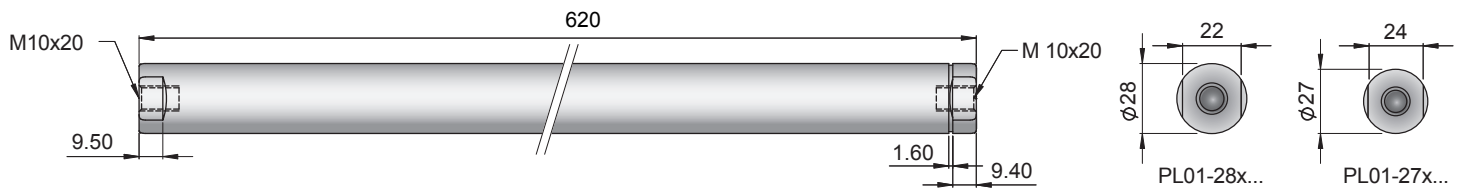

Standard Type	Slider Standard	PL01-28x620/540	0150-1383
Special Sliders	Heavy Duty Slider with WC/C-Coating	PL02-28x620/540	0150-1414
	Hollow Slider hole diameter 6mm	PL01-28x620/540-L	0150-1481
	High Clearance Slider d=27mm	PL01-27x620/540	on request

Connectors

Motor connector Wiring

P01-48...-C

Ph 1+	Red	A
Ph 1-	Pink	B
Ph 2+	Blue	C
Ph 2-	Grey	D
+5VDC	White	E
GND	Inner Shield	F
Sine	Yellow	G
Cosine	Green	H
Temp.	Black	L
Shield	Outer Shield	Case

Accessoires

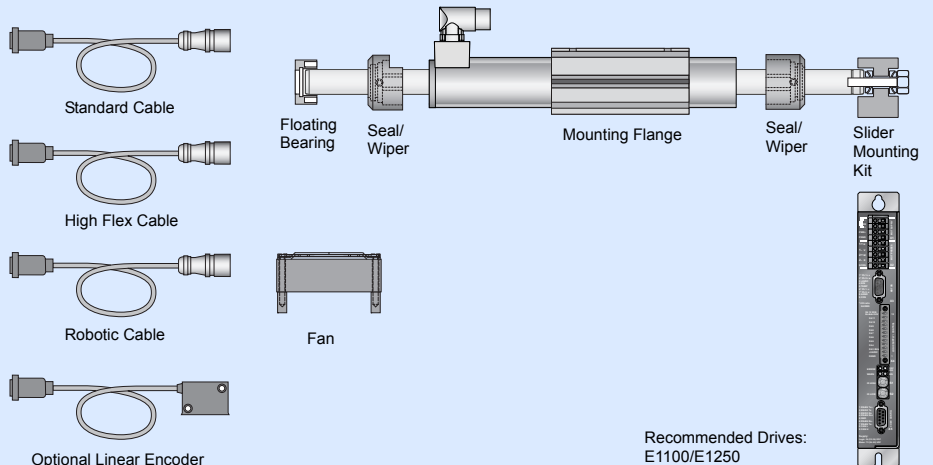

Max. Stroke: 420mm
Max. Force: 1024N

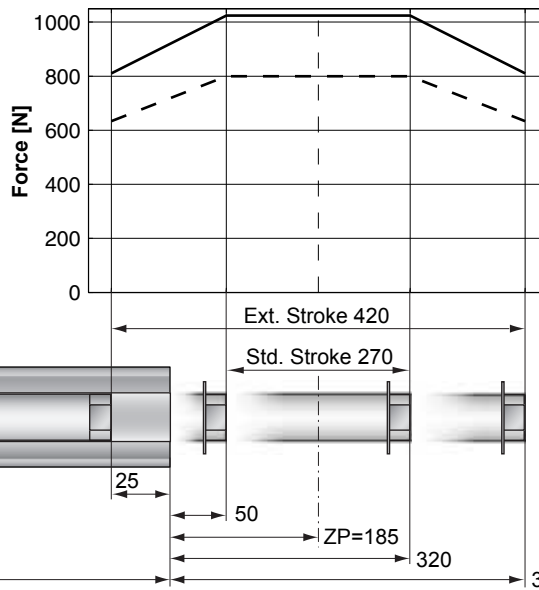

— E1250-UC, 72VDC
 - - - E1100-XC, 72VDC

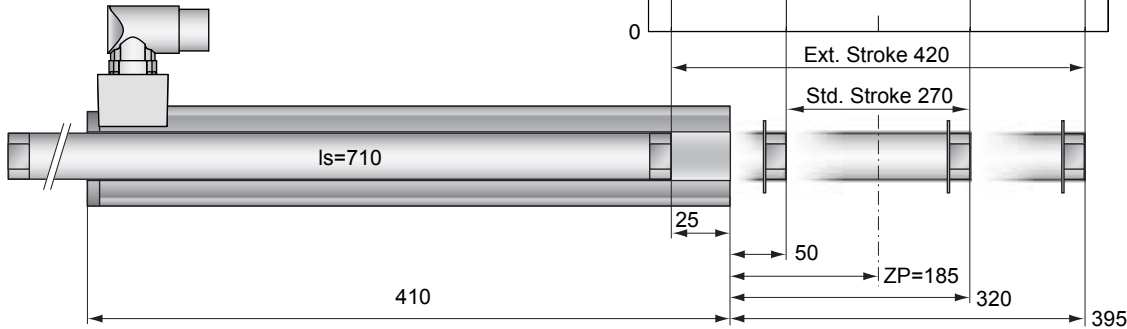

Dimensions in mm

Motor Specification

		F-Winding	
		48x360F/270x420-C	
	P01-		
Extended Stroke	mm (in)		420 (16.54)
Standard Stroke	mm (in)		270 (10.63)
Max. Force E1250-UC	N (lbf)		1024 (230.1)
Max. Force E1100-XC	N (lbf)		800 (179.8)
Cont. Force	N (lbf)		203 (45.7)
Cont. Force with fan	N (lbf)		354 (79.7)
Border Force	%		79
Force Constant	N/A (lbf/A)		32.0 (7.19)
Max. Current @ 72VDC	A		32.0
Max. Velocity @ 72VDC	m/s (in/s)		2.1 (82)
Phase Resist. 25/80 °C	Ohm		1.38/1.67
Phase Inductance	mH		1.6
Thermal Resistance	°K/W		0.8
Thermal Time Const.	sec		3200
Stator Diameter	mm (in)		48 (1.89)
Stator Length	mm (in)		410 (16.12)
Stator Mass	g (lb)		2880 (6.35)
Slider Diameter	mm (in)		28 (1.10)
Slider Length	mm (in)		710 (27.95)
Slider Mass	g (lb)		3140 (6.92)
Position Repeatability	mm (in)		±0.05 (±0.0020)
Linearity	%		±0.15
Repeatability with EPS	mm (in)		±0.01 (±0.0004)
Linearity with EPS	mm (in)		±0.01 (±0.0004)

Position-Time Diagram

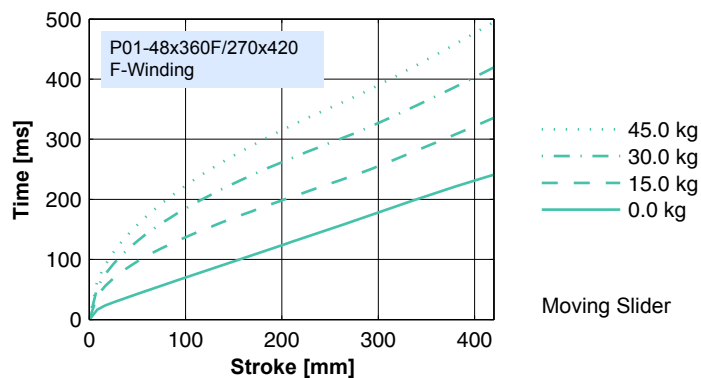

Moving Slider

Connector Type

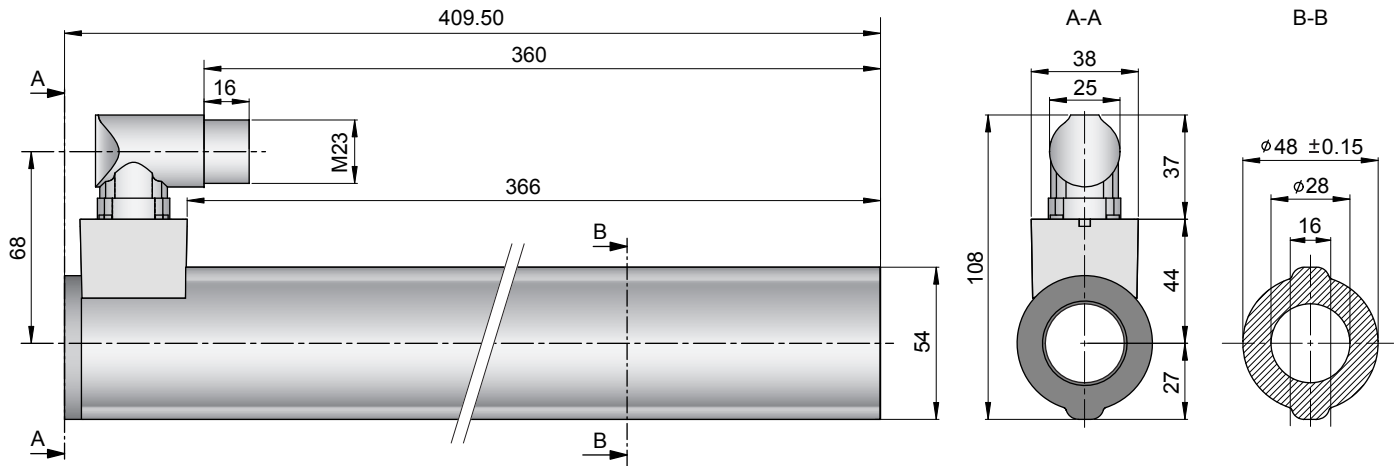

Linear Motor		Stator		Slider	
Type	Art.No	Type	Art. No.	Type	Art. No.
P01-48x360F/270x420-C	-->	PS01-48x360F-C	0150-1269	& PL01-28x710/630	0150-1384

Slider

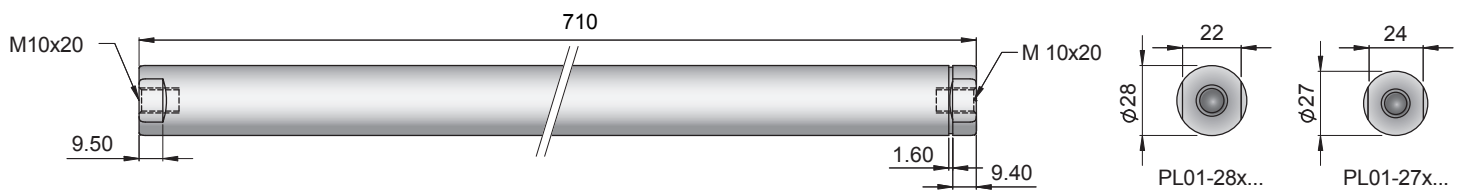

Standard Type	Slider Standard	PL01-28x710/630	0150-1384
Special Sliders	Heavy Duty Slider with WC/C-Coating	PL02-28x710/630	0150-1415
	Hollow Slider hole diameter 6mm	PL01-28x710/630-L	0150-1482
	High Clearance Slider d=27mm	PL01-27x710/630	on request

Connectors

Motor connector Wiring

		P01-48...-C
Ph 1+	Red	A
Ph 1-	Pink	B
Ph 2+	Blue	C
Ph 2-	Grey	D
+5VDC	White	E
GND	Inner Shield	F
Sine	Yellow	G
Cosine	Green	H
Temp.	Black	L
Shield	Outer Shield	Case

Accessoires

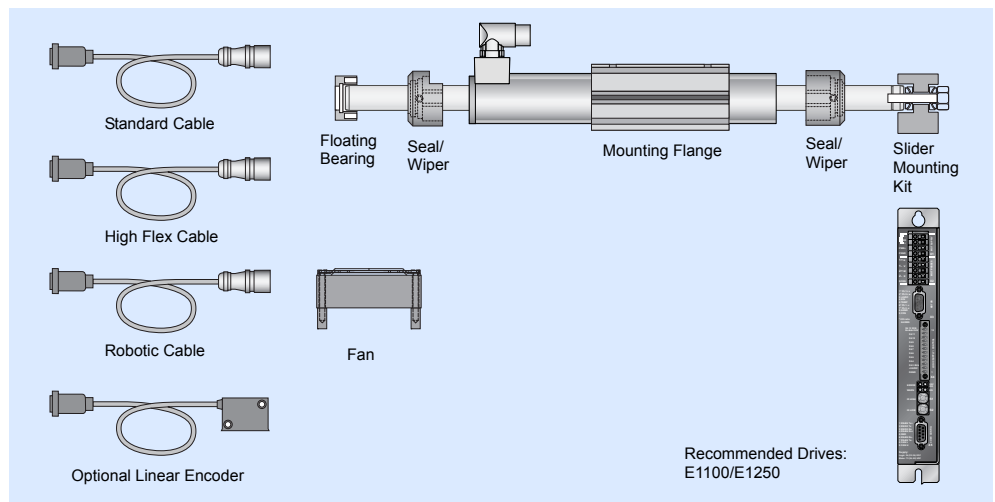

Max. Stroke: 510mm
Max. Force: 1024N

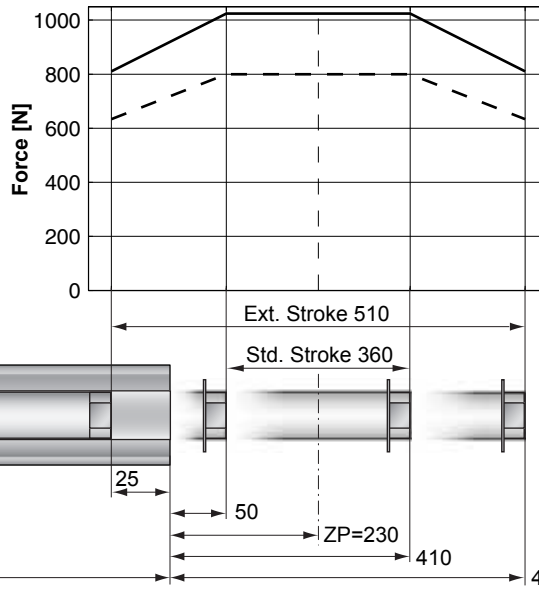

— E1250-UC, 72VDC
 - - - E1100-XC, 72VDC

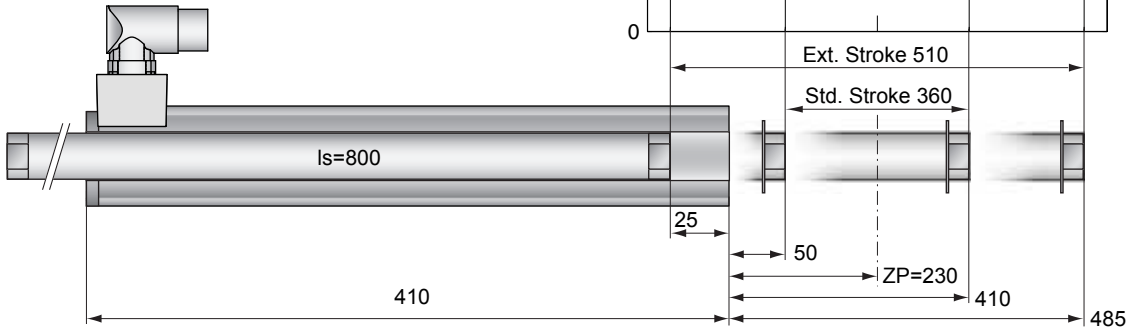

Dimensions in mm

Motor Specification

		F-Winding	
		48x360F/360x510-C	
Extended Stroke	mm (in)	510 (20.08)	
Standard Stroke	mm (in)	360 (14.17)	
Max. Force E1250-UC	N (lbf)	1024 (230.1)	
Max. Force E1100-XC	N (lbf)	800 (179.8)	
Cont. Force	N (lbf)	203 (45.7)	
Cont. Force with fan	N (lbf)	354 (79.7)	
Border Force	%	79	
Force Constant	N/A (lbf/A)	32.0 (7.19)	
Max. Current @ 72VDC	A	32.0	
Max. Velocity @ 72VDC	m/s (in/s)	2.1 (82)	
Phase Resist. 25/80 °C	Ohm	1.38/1.67	
Phase Inductance	mH	1.6	
Thermal Resistance	°K/W	0.8	
Thermal Time Const.	sec	3200	
Stator Diameter	mm (in)	48 (1.89)	
Stator Length	mm (in)	410 (16.12)	
Stator Mass	g (lb)	2880 (6.35)	
Slider Diameter	mm (in)	28 (1.10)	
Slider Length	mm (in)	800 (31.50)	
Slider Mass	g (lb)	3560 (7.85)	
Position Repeatability	mm (in)	±0.05 (±0.0020)	
Linearity	%	±0.15	
Repeatability with EPS	mm (in)	±0.01 (±0.0004)	
Linearity with EPS	mm (in)	±0.01 (±0.0004)	

Position-Time Diagram

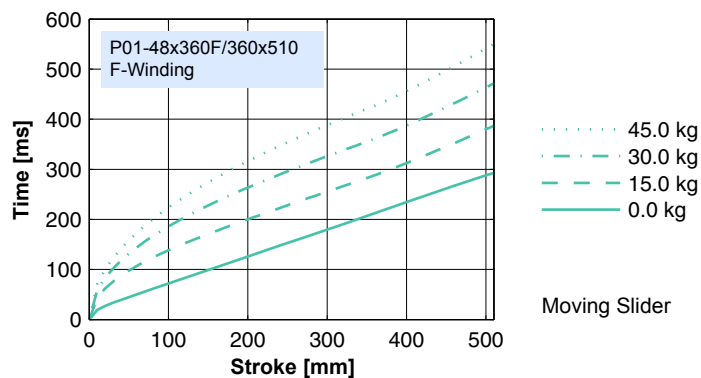

Moving Slider

Connector Type

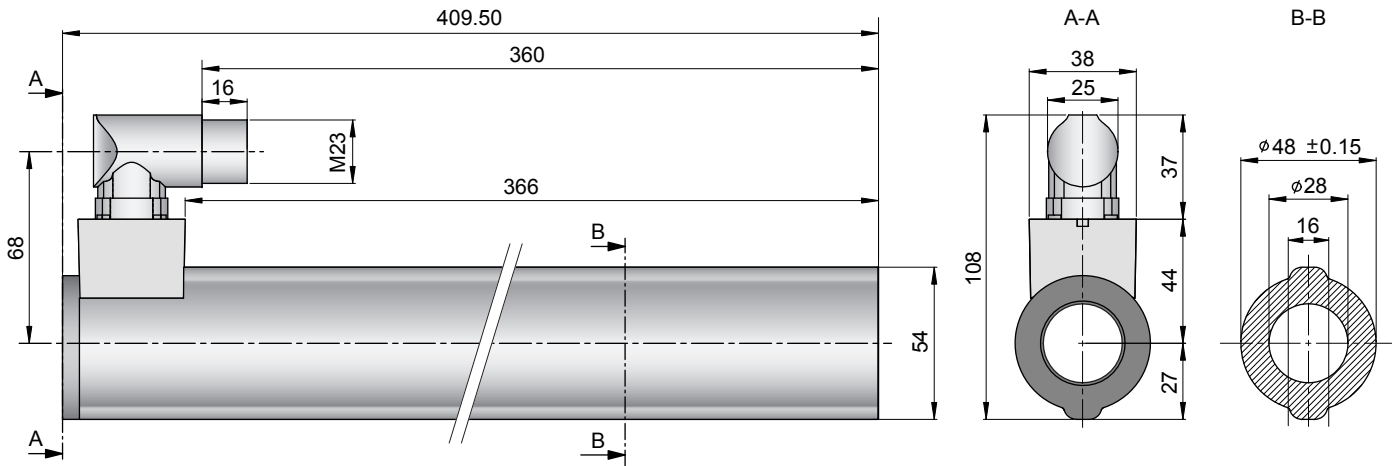

Linear Motor		Stator		Slider	
Type	Art.No	Type	Art. No.	Type	Art. No.
P01-48x360F/360x510-C	-->	PS01-48x360F-C	0150-1269	& PL01-28x800/720	0150-1385

Slider

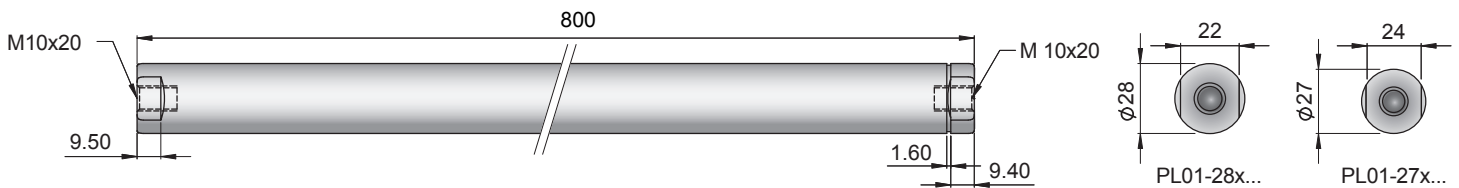

Standard Type	Slider Standard	PL01-28x800/720	0150-1385
Special Sliders	Heavy Duty Slider with WC/C-Coating	PL02-28x800/720	0150-1416
	Hollow Slider hole diameter 6mm	PL01-28x800/720-L	0150-1483
	High Clearance Slider d=27mm	PL01-27x800/720	on request

Connectors

Motor connector Wiring

		P01-48...-C
Ph 1+	Red	A
Ph 1-	Pink	B
Ph 2+	Blue	C
Ph 2-	Grey	D
+5VDC	White	E
GND	Inner Shield	F
Sine	Yellow	G
Cosine	Green	H
Temp.	Black	L
Shield	Outer Shield	Case

Accessoires

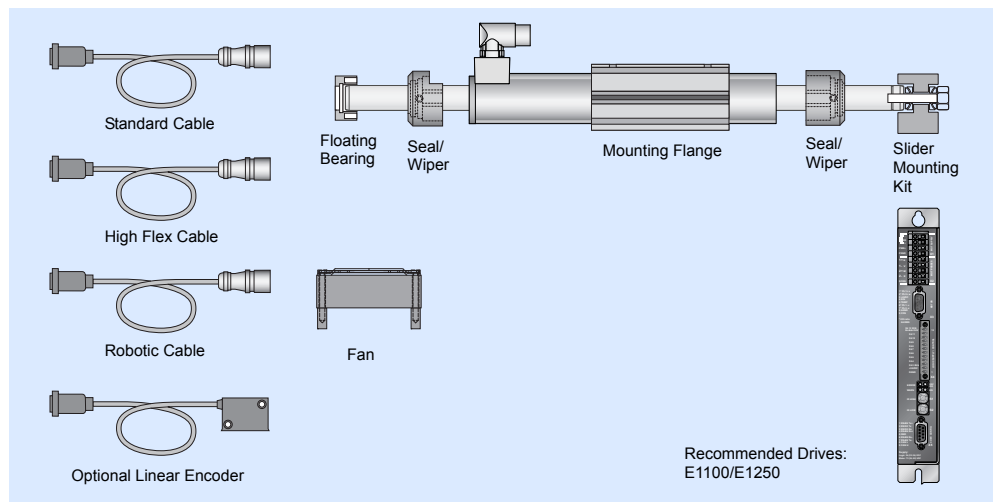

Max. Stroke: 630mm
Max. Force: 1024N

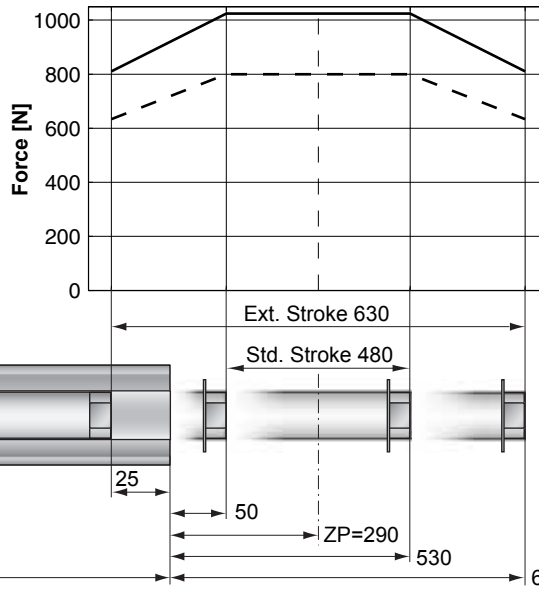

— E1250-UC, 72VDC
 - - - E1100-XC, 72VDC

Dimensions in mm

Motor Specification

		F-Winding	
		48x360F/480x630-C	
Extended Stroke	mm (in)	630 (24.80)	
Standard Stroke	mm (in)	480 (18.90)	
Max. Force E1250-UC	N (lbf)	1024 (230.1)	
Max. Force E1100-XC	N (lbf)	800 (179.8)	
Cont. Force	N (lbf)	203 (45.7)	
Cont. Force with fan	N (lbf)	354 (79.7)	
Border Force	%	79	
Force Constant	N/A (lbf/A)	32.0 (7.19)	
Max. Current @ 72VDC	A	32.0	
Max. Velocity @ 72VDC	m/s (in/s)	2.1 (82)	
Phase Resist. 25/80 °C	Ohm	1.38/1.67	
Phase Inductance	mH	1.6	
Thermal Resistance	°K/W	0.8	
Thermal Time Const.	sec	3200	
Stator Diameter	mm (in)	48 (1.89)	
Stator Length	mm (in)	410 (16.12)	
Stator Mass	g (lb)	2880 (6.35)	
Slider Diameter	mm (in)	28 (1.10)	
Slider Length	mm (in)	920 (36.22)	
Slider Mass	g (lb)	4120 (9.08)	
Position Repeatability	mm (in)	±0.05 (±0.0020)	
Linearity	%	±0.15	
Repeatability with EPS	mm (in)	±0.01 (±0.0004)	
Linearity with EPS	mm (in)	±0.01 (±0.0004)	

Position-Time Diagram

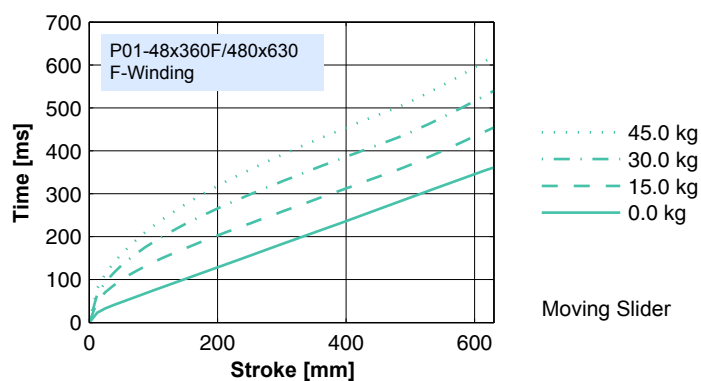

Moving Slider

Connector Type

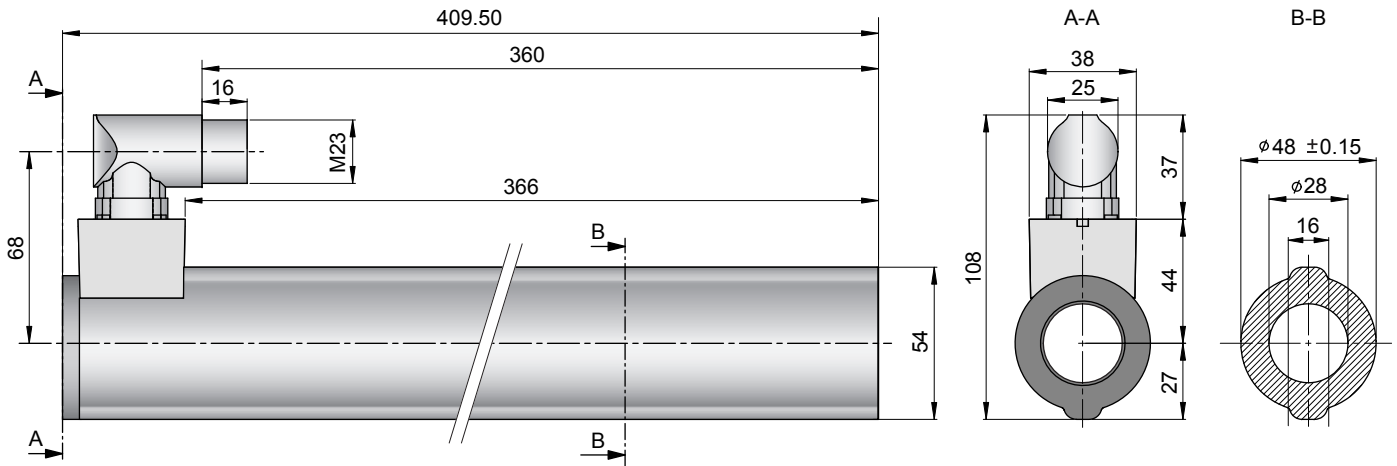

Linear Motor		Stator		Slider	
Type	Art.No	Type	Art. No.	Type	Art. No.
P01-48x360F/480x630-C	-->	PS01-48x360F-C	0150-1269	& PL01-28x920/840	0150-1386

Slider

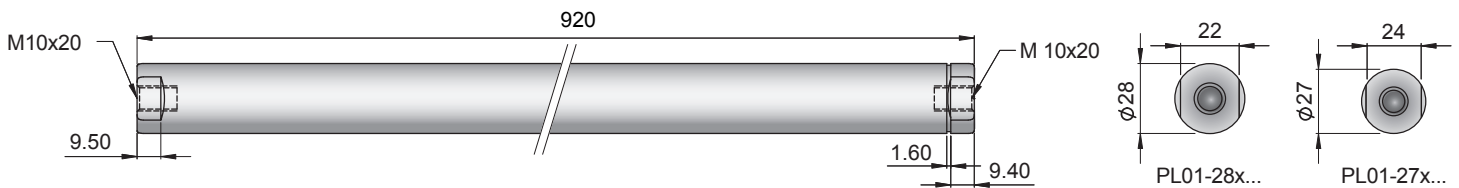

Standard Type	Slider Standard	PL01-28x920/840	0150-1386
Special Sliders	Heavy Duty Slider with WC/C-Coating	PL02-28x920/840	0150-1417
	Hollow Slider hole diameter 6mm	PL01-28x920/840-L	on request
	High Clearance Slider d=27mm	PL01-27x920/840	on request

Connectors

Motor connector Wiring

P01-48...-C

Ph 1+	Red	A
Ph 1-	Pink	B
Ph 2+	Blue	C
Ph 2-	Grey	D
+5VDC	White	E
GND	Inner Shield	F
Sine	Yellow	G
Cosine	Green	H
Temp.	Black	L
Shield	Outer Shield	Case

Accessoires

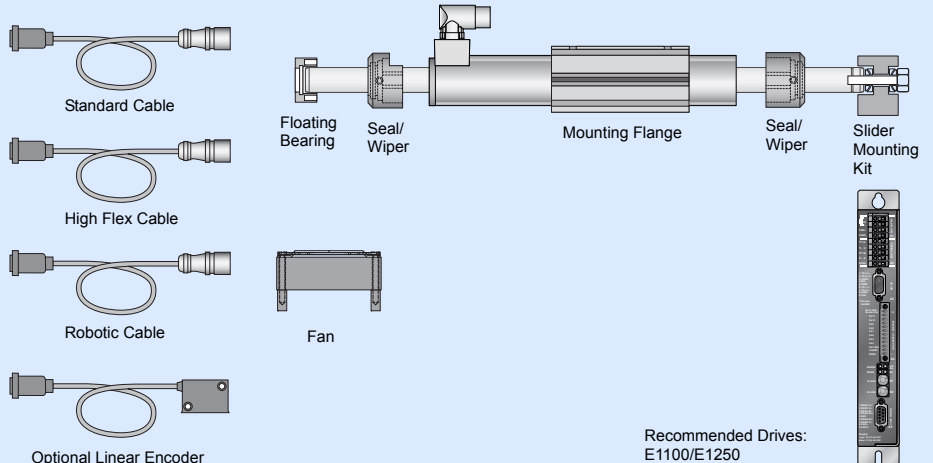

Recommended Drives:
E1100/E1250

Max. Stroke: 720mm
Max. Force: 1024N

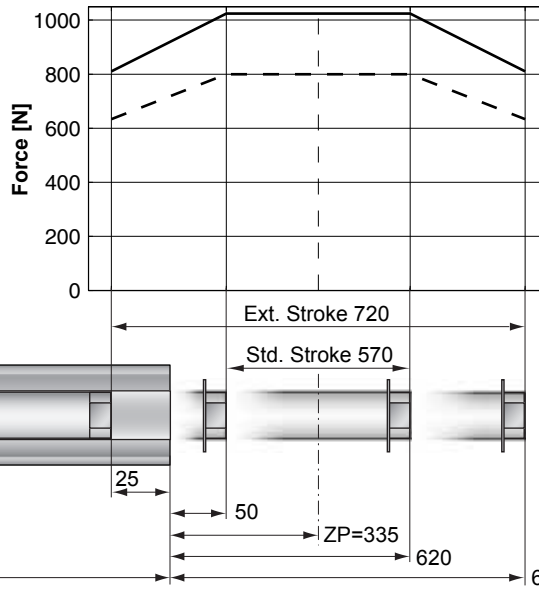

— E1250-UC, 72VDC
 - - - E1100-XC, 72VDC

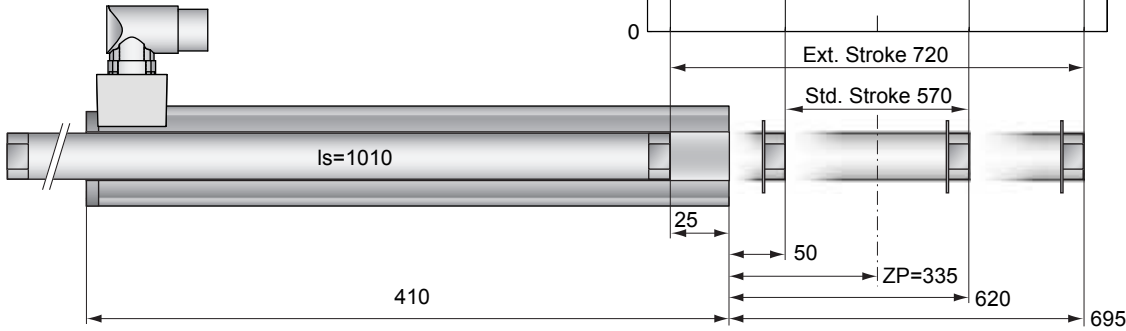

Dimensions in mm

Motor Specification

		F-Winding	
		48x360F/570x720-C	
Extended Stroke	mm (in)	720 (28.35)	
Standard Stroke	mm (in)	570 (22.44)	
Max. Force E1250-UC	N (lbf)	1024 (230.1)	
Max. Force E1100-XC	N (lbf)	800 (179.8)	
Cont. Force	N (lbf)	203 (45.7)	
Cont. Force with fan	N (lbf)	354 (79.7)	
Border Force	%	79	
Force Constant	N/A (lbf/A)	32.0 (7.19)	
Max. Current @ 72VDC	A	32.0	
Max. Velocity @ 72VDC	m/s (in/s)	2.1 (82)	
Phase Resist. 25/80 °C	Ohm	1.38/1.67	
Phase Inductance	mH	1.6	
Thermal Resistance	°K/W	0.8	
Thermal Time Const.	sec	3200	
Stator Diameter	mm (in)	48 (1.89)	
Stator Length	mm (in)	410 (16.12)	
Stator Mass	g (lb)	2880 (6.35)	
Slider Diameter	mm (in)	28 (1.10)	
Slider Length	mm (in)	1010 (39.76)	
Slider Mass	g (lb)	4540 (10.01)	
Position Repeatability	mm (in)	±0.05 (±0.0020)	
Linearity	%	±0.10	
Repeatability with EPS	mm (in)	±0.01 (±0.0004)	
Linearity with EPS	mm (in)	±0.01 (±0.0004)	

Position-Time Diagram

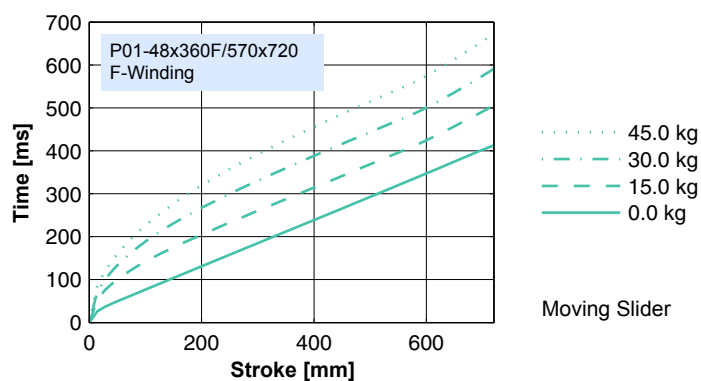

Connector Type

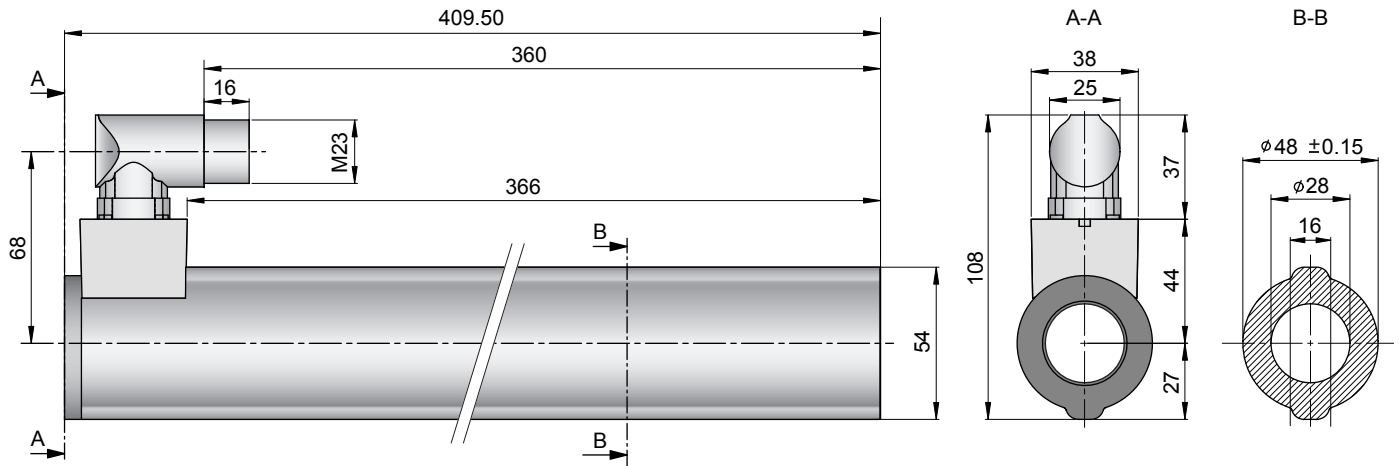

Linear Motor		Stator		Slider	
Type	Art.No	Type	Art. No.	Type	Art. No.
P01-48x360F/570x720-C	-->	PS01-48x360F-C	0150-1269	& PL01-28x1010/930	0150-1387

Slider

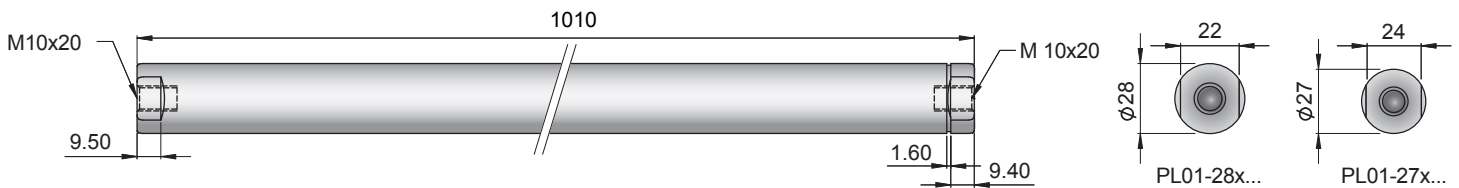

Standard Type	Slider Standard	PL01-28x1010/930	0150-1387
Special Sliders	Heavy Duty Slider with WC/C-Coating	PL02-28x1010/930	on request
	Hollow Slider hole diameter 6mm	PL01-28x1010/930-L	on request
	High Clearance Slider d=27mm	PL01-27x1010/930	on request

Connectors

Motor connector Wiring

P01-48...-C

Ph 1+	Red	A
Ph 1-	Pink	B
Ph 2+	Blue	C
Ph 2-	Grey	D
+5VDC	White	E
GND	Inner Shield	F
Sine	Yellow	G
Cosine	Green	H
Temp.	Black	L
Shield	Outer Shield	Case

Accessoires

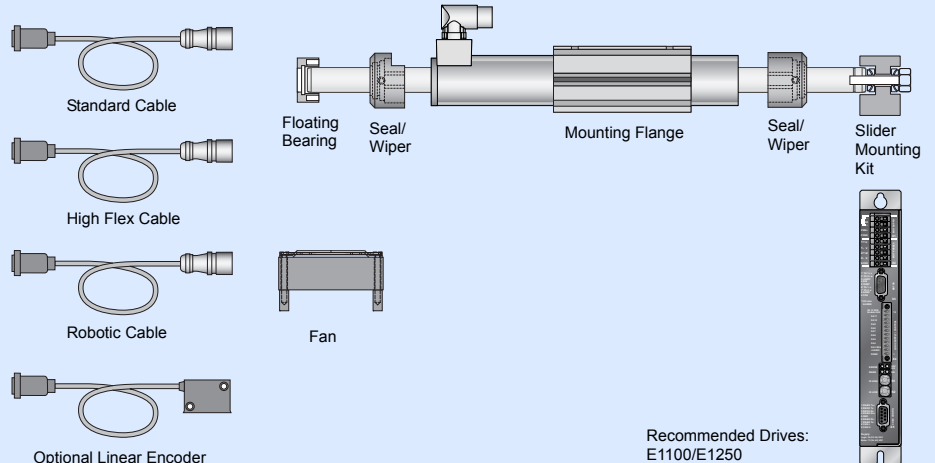

Recommended Drives:
E1100/E1250

Max. Stroke: 930mm
Max. Force: 1024N

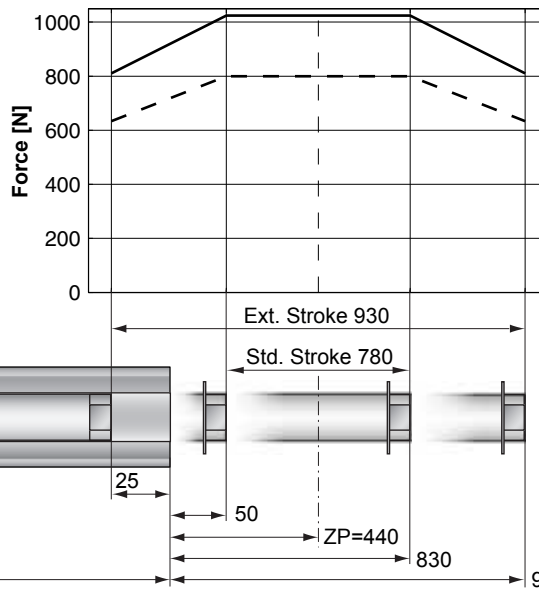

— E1250-UC, 72VDC
 - - - E1100-XC, 72VDC

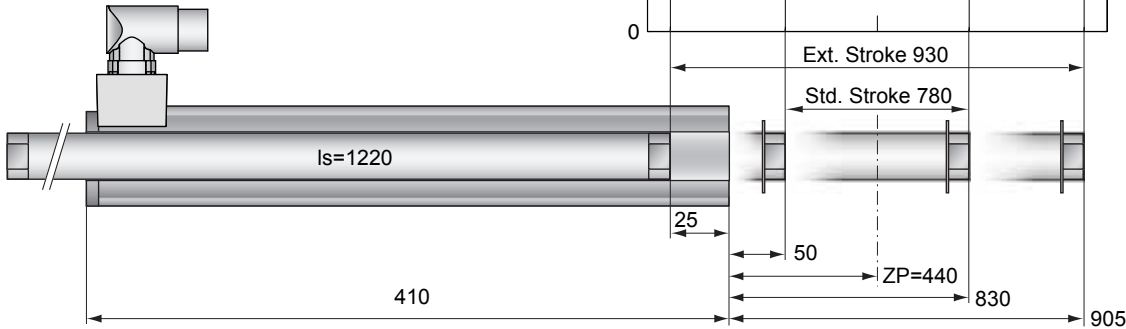

Dimensions in mm

Motor Specification

		F-Winding	
		48x360F/780x930-C	
Extended Stroke	mm (in)	930 (36.61)	
Standard Stroke	mm (in)	780 (30.71)	
Max. Force E1250-UC	N (lbf)	1024 (230.1)	
Max. Force E1100-XC	N (lbf)	800 (179.8)	
Cont. Force	N (lbf)	203 (45.7)	
Cont. Force with fan	N (lbf)	354 (79.7)	
Border Force	%	79	
Force Constant	N/A (lbf/A)	32.0 (7.19)	
Max. Current @ 72VDC	A	32.0	
Max. Velocity @ 72VDC	m/s (in/s)	2.1 (82)	
Phase Resist. 25/80 °C	Ohm	1.38/1.67	
Phase Inductance	mH	1.6	
Thermal Resistance	°K/W	0.8	
Thermal Time Const.	sec	3200	
Stator Diameter	mm (in)	48 (1.89)	
Stator Length	mm (in)	410 (16.12)	
Stator Mass	g (lb)	2880 (6.35)	
Slider Diameter	mm (in)	28 (1.10)	
Slider Length	mm (in)	1220 (48.03)	
Slider Mass	g (lb)	5510 (12.15)	
Position Repeatability	mm (in)	±0.05 (±0.0020)	
Linearity	%	±0.10	
Repeatability with EPS	mm (in)	±0.01 (±0.0004)	
Linearity with EPS	mm (in)	±0.01 (±0.0004)	

Position-Time Diagram

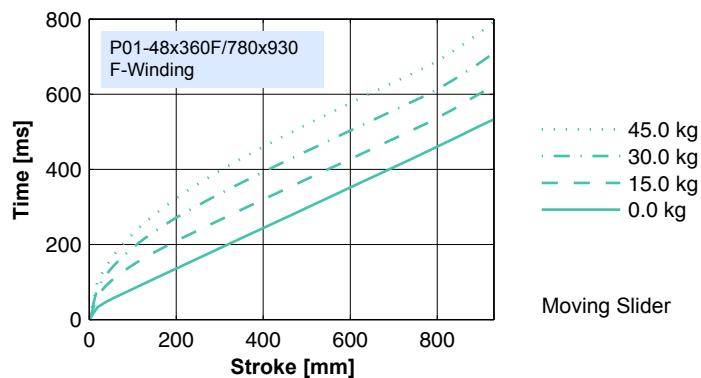

Connector Type

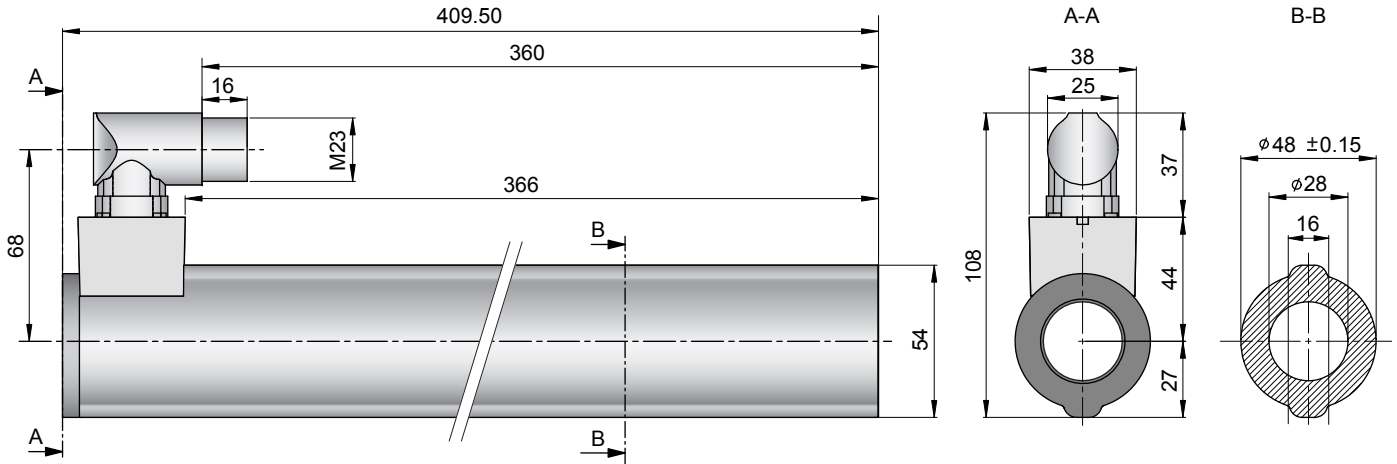

Linear Motor		Stator		Slider	
Type	Art.No	Type	Art. No.	Type	Art. No.
P01-48x360F/780x930-C	-->	PS01-48x360F-C	0150-1269	& PL01-28x1220/1140	0150-1388

Slider

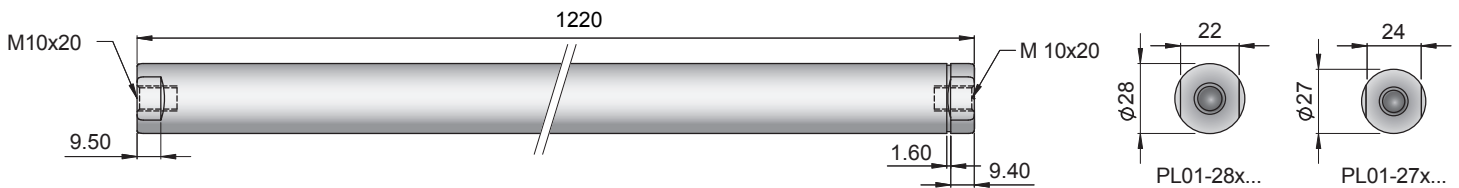

Standard Type	Slider Standard	PL01-28x1220/1140	0150-1388
Special Sliders	Heavy Duty Slider with WC/C-Coating	PL02-28x1220/1140	on request
	Hollow Slider hole diameter 6mm	PL01-28x1220/1140-L	on request
	High Clearance Slider d=27mm	PL01-27x1220/1140	on request

Connectors

Motor connector Wiring

P01-48...-C

Ph 1+	Red	A
Ph 1-	Pink	B
Ph 2+	Blue	C
Ph 2-	Grey	D
+5VDC	White	E
GND	Inner Shield	F
Sine	Yellow	G
Cosine	Green	H
Temp.	Black	L
Shield	Outer Shield	Case

Accessoires

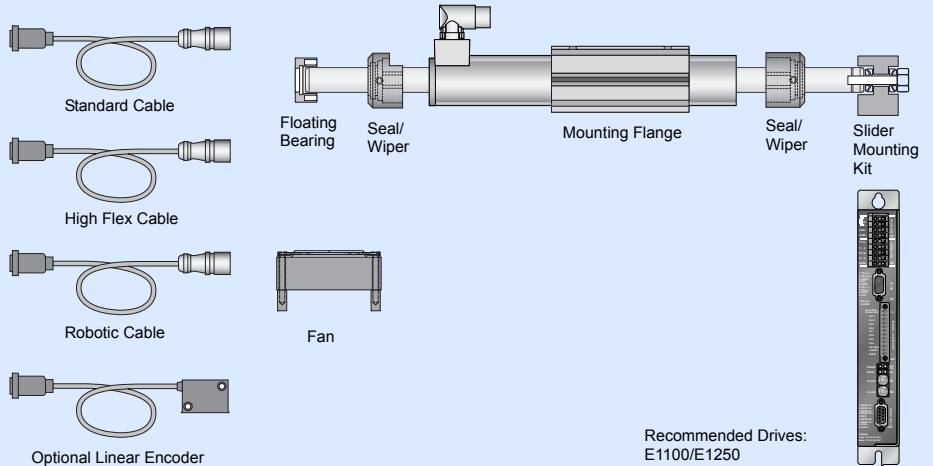

Max. Stroke: 1110mm
Max. Force: 1024N

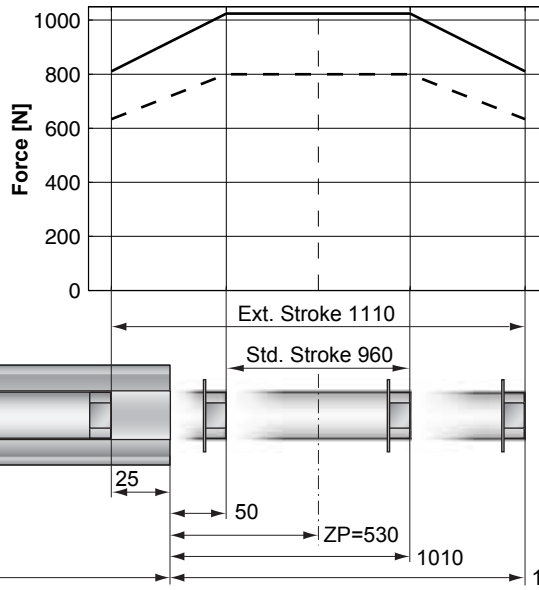

— E1250-UC, 72VDC
 - - - E1100-XC, 72VDC

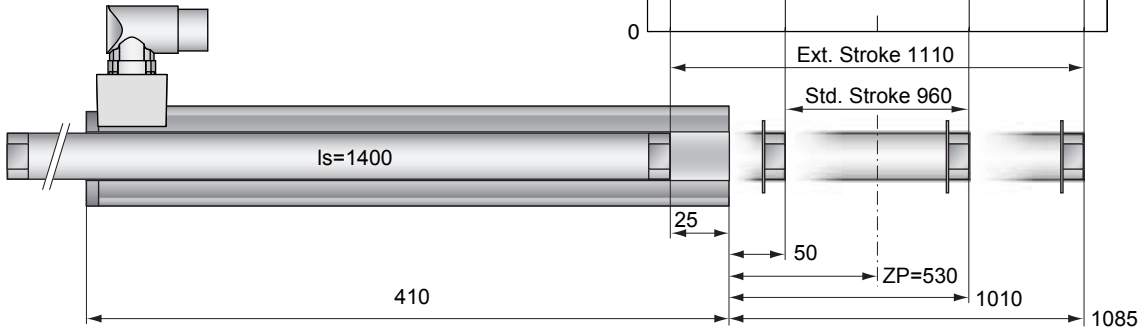

Dimensions in mm

Motor Specification

		F-Winding	
		48x360F/960x1110-C	
Extended Stroke	mm (in)	1110 (43.70)	
Standard Stroke	mm (in)	960 (37.80)	
Max. Force E1250-UC	N (lbf)	1024 (230.1)	
Max. Force E1100-XC	N (lbf)	800 (179.8)	
Cont. Force	N (lbf)	203 (45.7)	
Cont. Force with fan	N (lbf)	354 (79.7)	
Border Force	%	79	
Force Constant	N/A (lbf/A)	32.0 (7.19)	
Max. Current @ 72VDC	A	32.0	
Max. Velocity @ 72VDC	m/s (in/s)	2.1 (82)	
Phase Resist. 25/80 °C	Ohm	1.38/1.67	
Phase Inductance	mH	1.6	
Thermal Resistance	°K/W	0.8	
Thermal Time Const.	sec	3200	
Stator Diameter	mm (in)	48 (1.89)	
Stator Length	mm (in)	410 (16.12)	
Stator Mass	g (lb)	2880 (6.35)	
Slider Diameter	mm (in)	28 (1.10)	
Slider Length	mm (in)	1400 (55.12)	
Slider Mass	g (lb)	6350 (14.00)	
Position Repeatability	mm (in)	±0.05 (±0.0020)	
Linearity	%	±0.10	
Repeatability with EPS	mm (in)	±0.01 (±0.0004)	
Linearity with EPS	mm (in)	±0.01 (±0.0004)	

Position-Time Diagram

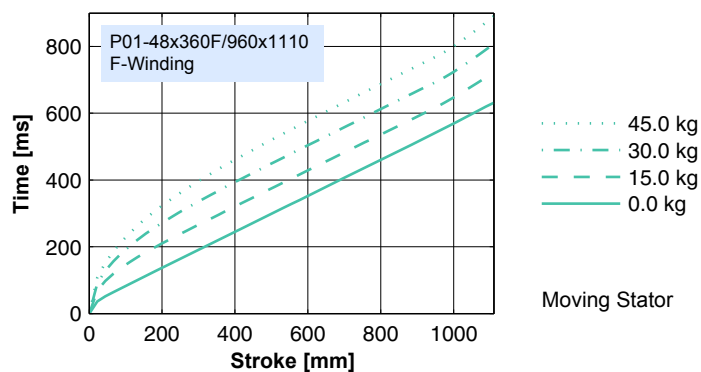

Connector Type

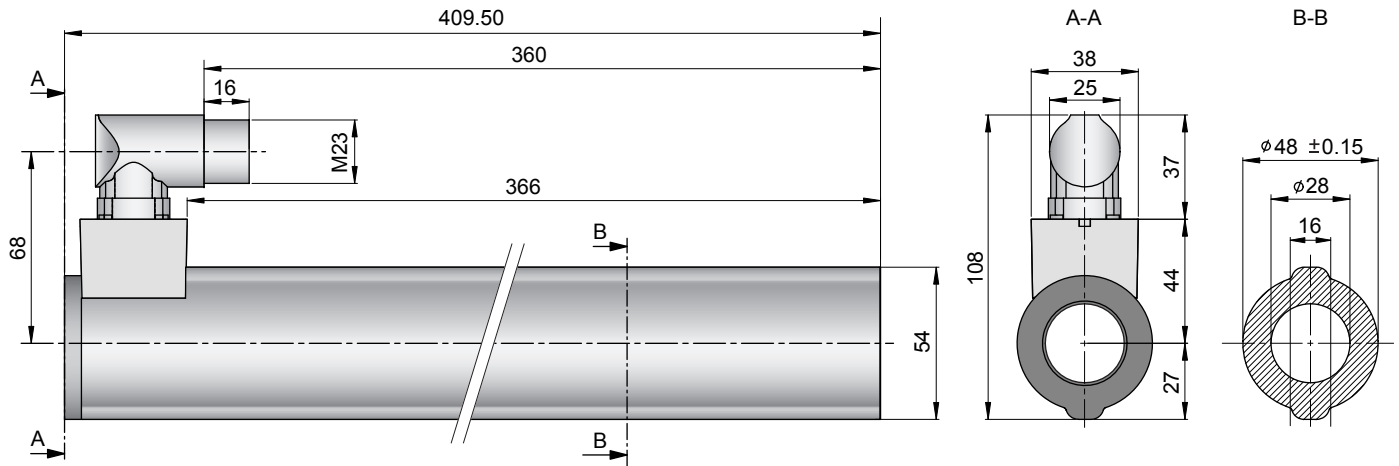

Linear Motor		Stator		Slider	
Type	Art.No	Type	Art. No.	Type	Art. No.
P01-48x360F/960x1110-C	-->	PS01-48x360F-C	0150-1269	& PL01-28x1400/1320	0150-1389

Slider

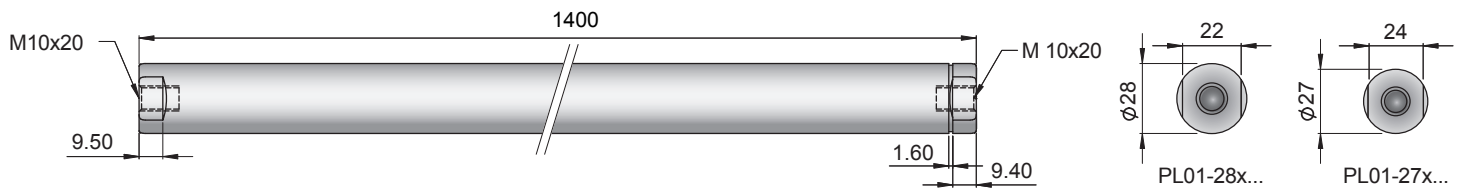

Standard Type	Slider Standard	PL01-28x1400/1320	0150-1389
Special Sliders	Heavy Duty Slider with WC/C-Coating	PL02-28x1400/1320	on request
	Hollow Slider hole diameter 6mm	PL01-28x1400/1320-L	on request
	High Clearance Slider d=27mm	PL01-27x1400/1320	on request

Connectors

Motor connector Wiring

P01-48...-C

Ph 1+	Red	A
Ph 1-	Pink	B
Ph 2+	Blue	C
Ph 2-	Grey	D
+5VDC	White	E
GND	Inner Shield	F
Sine	Yellow	G
Cosine	Green	H
Temp.	Black	L
Shield	Outer Shield	Case

Accessoires

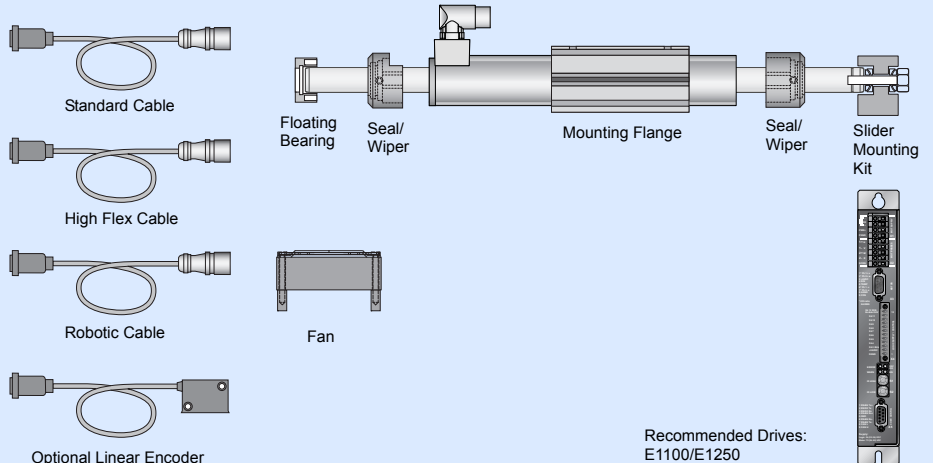

Recommended Drives:
E1100/E1250

Max. Stroke: 1320mm
Max. Force: 1024N

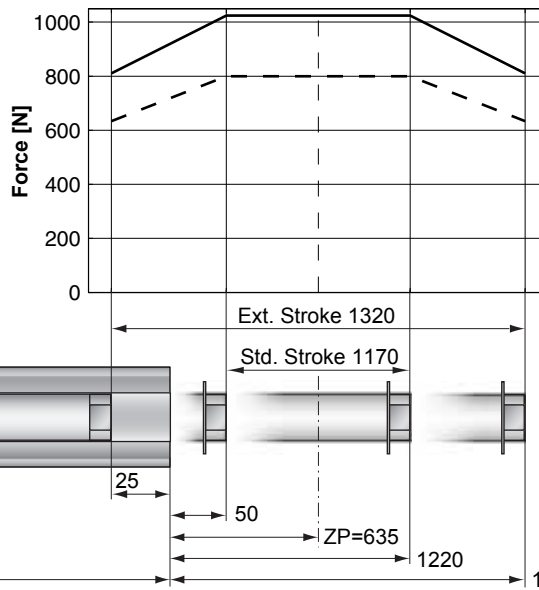

— E1250-UC, 72VDC
 - - - E1100-XC, 72VDC

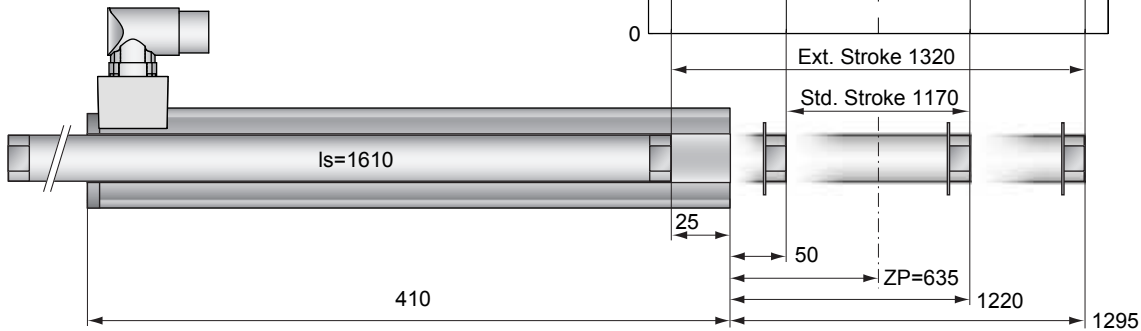

Dimensions in mm

Motor Specification

		F-Winding	
		48x360F/1170x1320-C	
Extended Stroke	mm (in)	1320 (51.97)	
Standard Stroke	mm (in)	1170 (46.06)	
Max. Force E1250-UC	N (lbf)	1024 (230.1)	
Max. Force E1100-XC	N (lbf)	800 (179.8)	
Cont. Force	N (lbf)	203 (45.7)	
Cont. Force with fan	N (lbf)	354 (79.7)	
Border Force	%	79	
Force Constant	N/A (lbf/A)	32.0 (7.19)	
Max. Current @ 72VDC	A	32.0	
Max. Velocity @ 72VDC	m/s (in/s)	2.1 (82)	
Phase Resist. 25/80 °C	Ohm	1.38/1.67	
Phase Inductance	mH	1.6	
Thermal Resistance	°K/W	0.8	
Thermal Time Const.	sec	3200	
Stator Diameter	mm (in)	48 (1.89)	
Stator Length	mm (in)	410 (16.12)	
Stator Mass	g (lb)	2880 (6.35)	
Slider Diameter	mm (in)	28 (1.10)	
Slider Length	mm (in)	1610 (63.39)	
Slider Mass	g (lb)	7330 (16.16)	
Position Repeatability	mm (in)	±0.05 (±0.0020)	
Linearity	%	±0.10	
Repeatability with EPS	mm (in)	±0.01 (±0.0004)	
Linearity with EPS	mm (in)	±0.01 (±0.0004)	

Position-Time Diagram

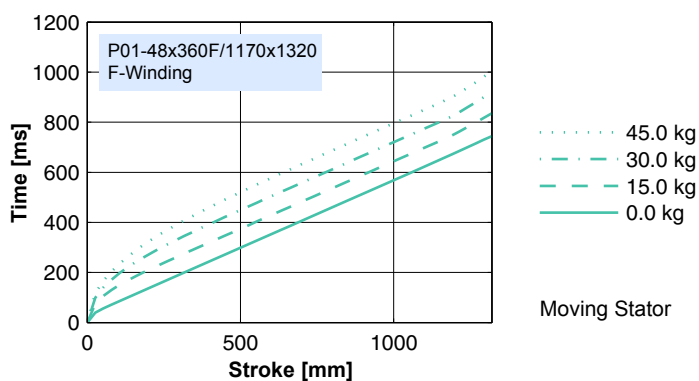

Moving Stator

Connector Type

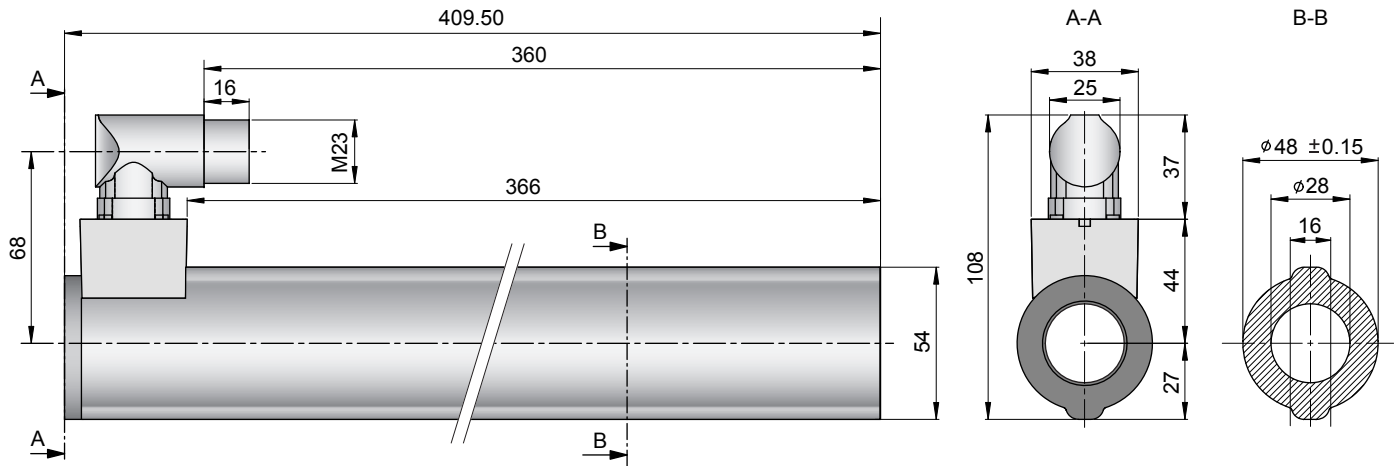

Linear Motor		Stator		Slider	
Type	Art.No	Type	Art. No.	Type	Art. No.
P01-48x360F/1170x1320-C	-->	PS01-48x360F-C	0150-1269	& PL01-28x1610/1530	0150-1390

Slider

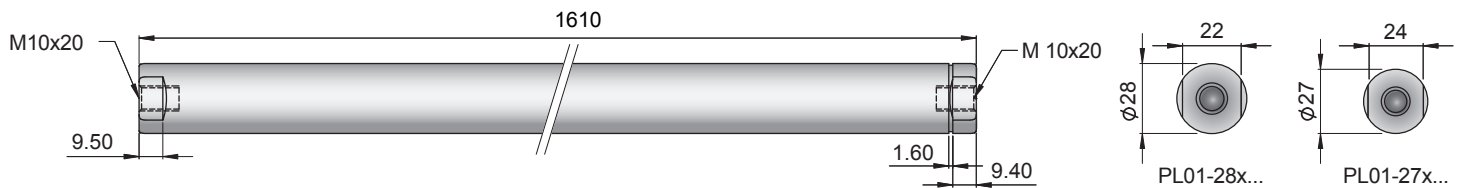

Standard Type	Slider Standard	PL01-28x1610/1530	0150-1390
Special Sliders	Heavy Duty Slider with WC/C-Coating	PL02-28x1610/1530	on request
	Hollow Slider hole diameter 6mm	PL01-28x1610/1530-L	on request
	High Clearance Slider d=27mm	PL01-27x1610/1530	on request

Connectors

Motor connector Wiring

P01-48...-C

Ph 1+	Red	A
Ph 1-	Pink	B
Ph 2+	Blue	C
Ph 2-	Grey	D
+5VDC	White	E
GND	Inner Shield	F
Sine	Yellow	G
Cosine	Green	H
Temp.	Black	L
Shield	Outer Shield	Case

Accessoires

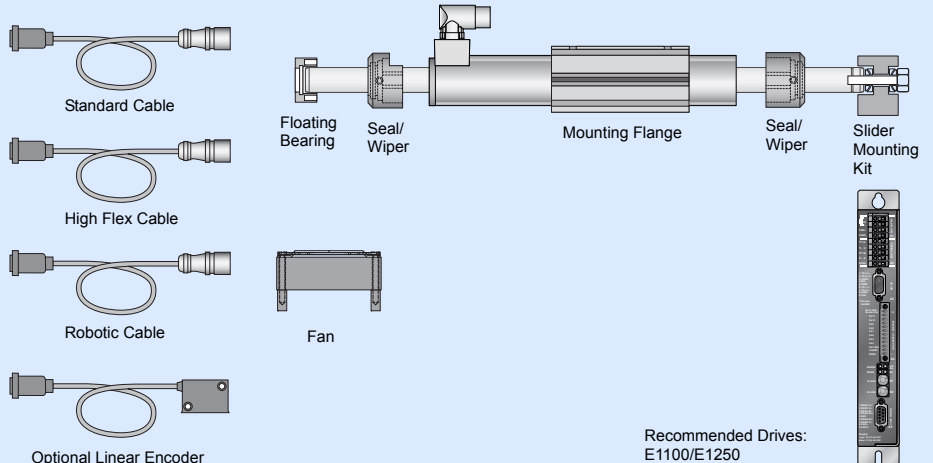

Recommended Drives:
E1100/E1250

Max. Stroke: 1530mm
Max. Force: 1024N

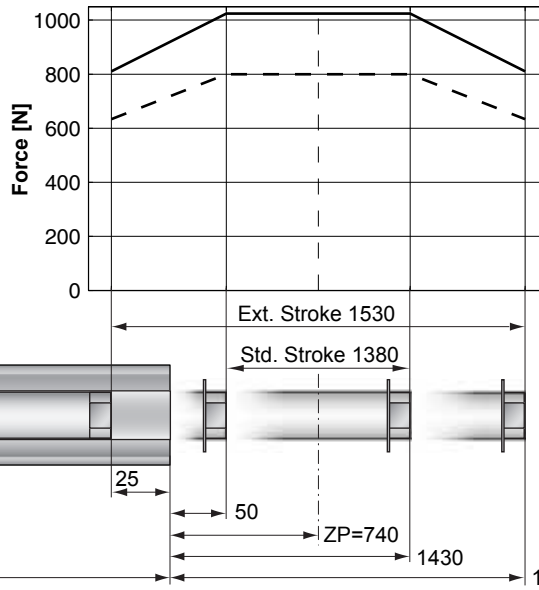

— E1250-UC, 72VDC
 - - - E1100-XC, 72VDC

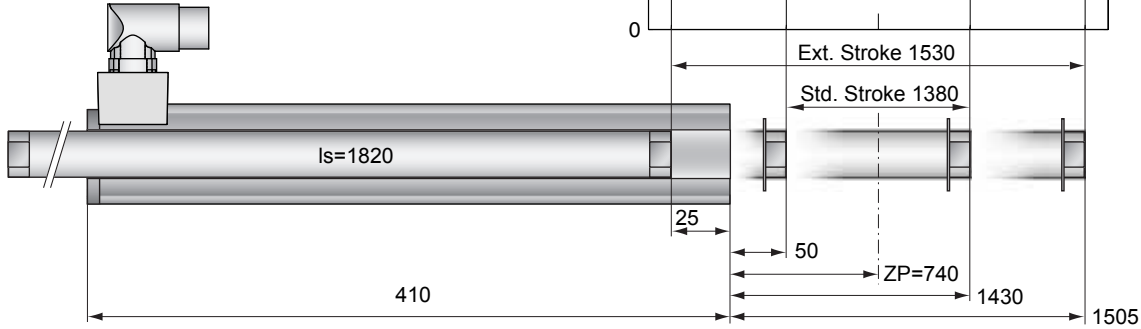

Dimensions in mm

Motor Specification

		F-Winding	
		48x360F/1380x1530-C	
Extended Stroke	mm (in)	1530 (60.24)	
Standard Stroke	mm (in)	1380 (54.33)	
Max. Force E1250-UC	N (lbf)	1024 (230.1)	
Max. Force E1100-XC	N (lbf)	800 (179.8)	
Cont. Force	N (lbf)	203 (45.7)	
Cont. Force with fan	N (lbf)	354 (79.7)	
Border Force	%	79	
Force Constant	N/A (lbf/A)	32.0 (7.19)	
Max. Current @ 72VDC	A	32.0	
Max. Velocity @ 72VDC	m/s (in/s)	2.1 (82)	
Phase Resist. 25/80 °C	Ohm	1.38/1.67	
Phase Inductance	mH	1.6	
Thermal Resistance	°K/W	0.8	
Thermal Time Const.	sec	3200	
Stator Diameter	mm (in)	48 (1.89)	
Stator Length	mm (in)	410 (16.12)	
Stator Mass	g (lb)	2880 (6.35)	
Slider Diameter	mm (in)	28 (1.10)	
Slider Length	mm (in)	1820 (71.65)	
Slider Mass	g (lb)	8300 (18.30)	
Position Repeatability	mm (in)	±0.05 (±0.0020)	
Linearity	%	±0.10	
Repeatability with EPS	mm (in)	±0.01 (±0.0004)	
Linearity with EPS	mm (in)	±0.01 (±0.0004)	

Position-Time Diagram

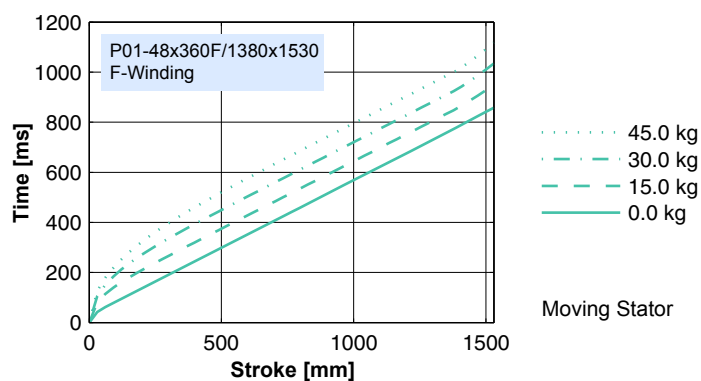

Moving Stator

Connector Type

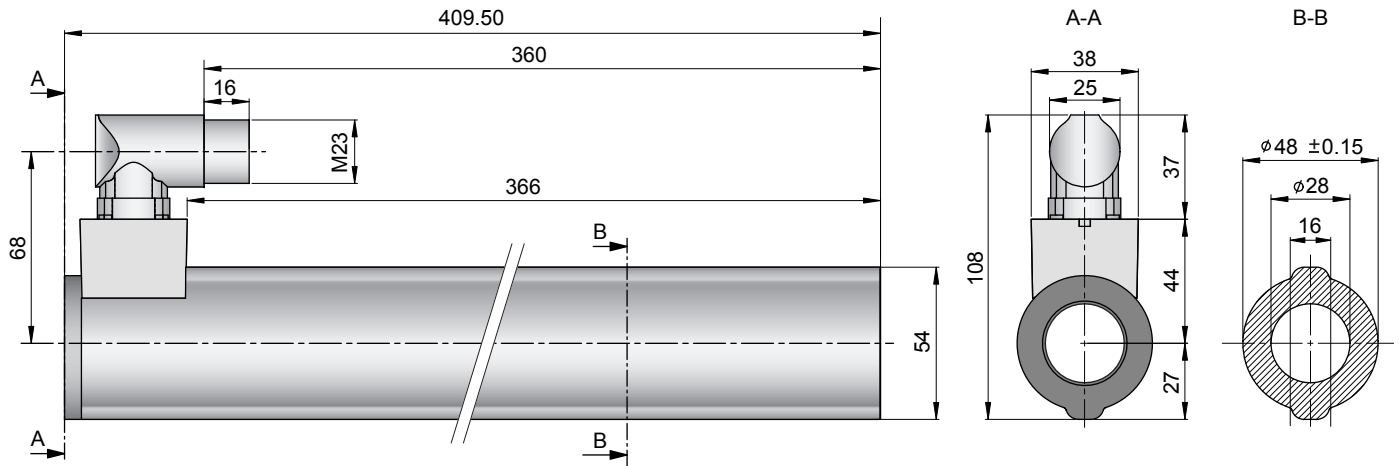

Linear Motor		Stator		Slider	
Type	Art.No	Type	Art. No.	Type	Art. No.
P01-48x360F/1380x1530-C	-->	PS01-48x360F-C	0150-1269	& PL01-28x1820/1740	0150-1395

Slider

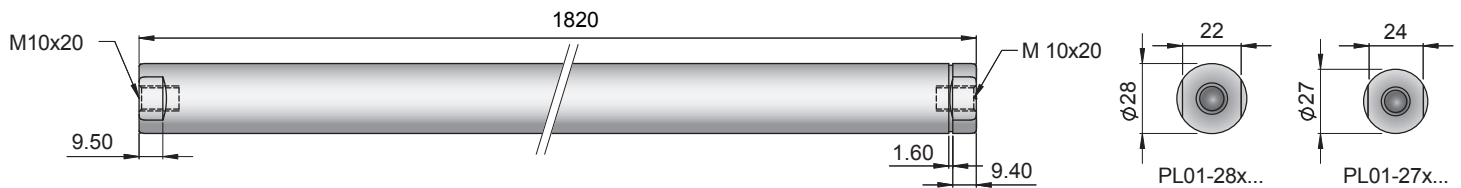

Standard Type	Slider Standard	PL01-28x1820/1740	0150-1395
Special Sliders	Heavy Duty Slider with WC/C-Coating	PL02-28x1820/1740	on request
	Hollow Slider hole diameter 6mm	PL01-28x1820/1740-L	on request
	High Clearance Slider d=27mm	PL01-27x1820/1740	on request

Connectors

Motor connector Wiring

P01-48...-C

Ph 1+	Red	A
Ph 1-	Pink	B
Ph 2+	Blue	C
Ph 2-	Grey	D
+5VDC	White	E
GND	Inner Shield	F
Sine	Yellow	G
Cosine	Green	H
Temp.	Black	L
Shield	Outer Shield	Case

Accessoires

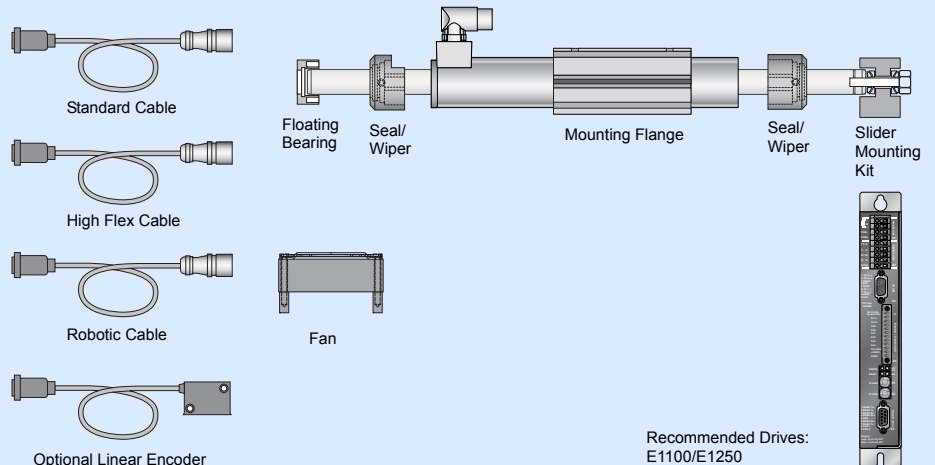

Max. Stroke: 1710mm
Max. Force: 1024N

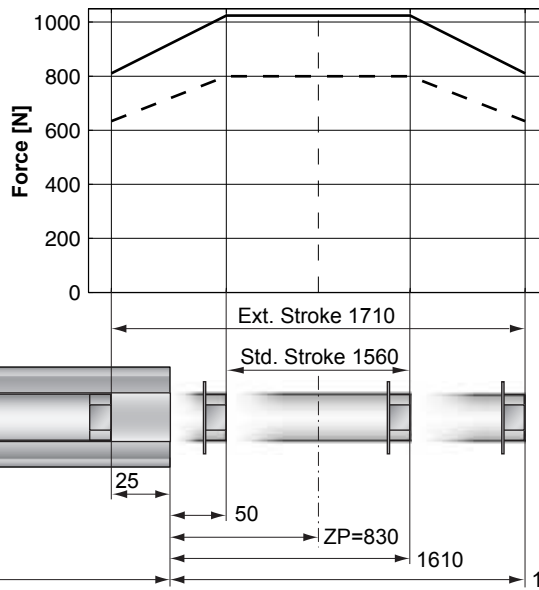

— E1250-UC, 72VDC
 - - - E1100-XC, 72VDC

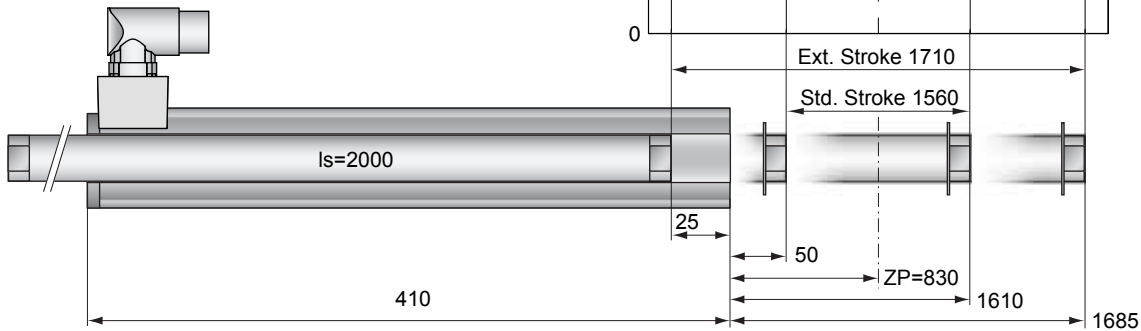

Dimensions in mm

Motor Specification

		F-Winding	
		48x360F/1560x1710-C	
Extended Stroke	mm (in)	1710 (67.32)	
Standard Stroke	mm (in)	1560 (61.42)	
Max. Force E1250-UC	N (lbf)	1024 (230.1)	
Max. Force E1100-XC	N (lbf)	800 (179.8)	
Cont. Force	N (lbf)	203 (45.7)	
Cont. Force with fan	N (lbf)	354 (79.7)	
Border Force	%	79	
Force Constant	N/A (lbf/A)	32.0 (7.19)	
Max. Current @ 72VDC	A	32.0	
Max. Velocity @ 72VDC	m/s (in/s)	2.1 (82)	
Phase Resist. 25/80 °C	Ohm	1.38/1.67	
Phase Inductance	mH	1.6	
Thermal Resistance	°K/W	0.8	
Thermal Time Const.	sec	3200	
Stator Diameter	mm (in)	48 (1.89)	
Stator Length	mm (in)	410 (16.12)	
Stator Mass	g (lb)	2880 (6.35)	
Slider Diameter	mm (in)	28 (1.10)	
Slider Length	mm (in)	2000 (78.74)	
Slider Mass	g (lb)	9140 (20.15)	
Position Repeatability	mm (in)	±0.05 (±0.0020)	
Linearity	%	±0.10	
Repeatability with EPS	mm (in)	±0.01 (±0.0004)	
Linearity with EPS	mm (in)	±0.01 (±0.0004)	

Position-Time Diagram

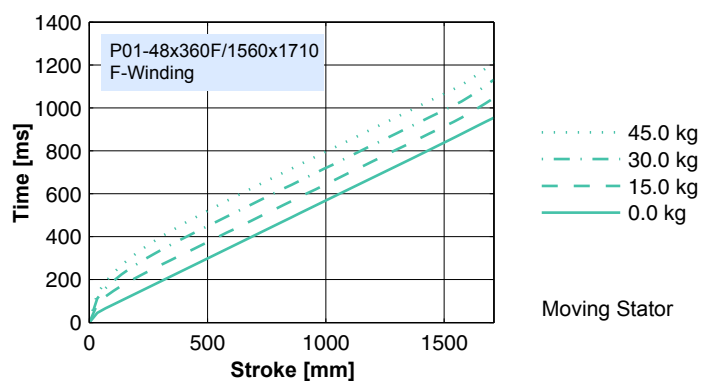

Connector Type

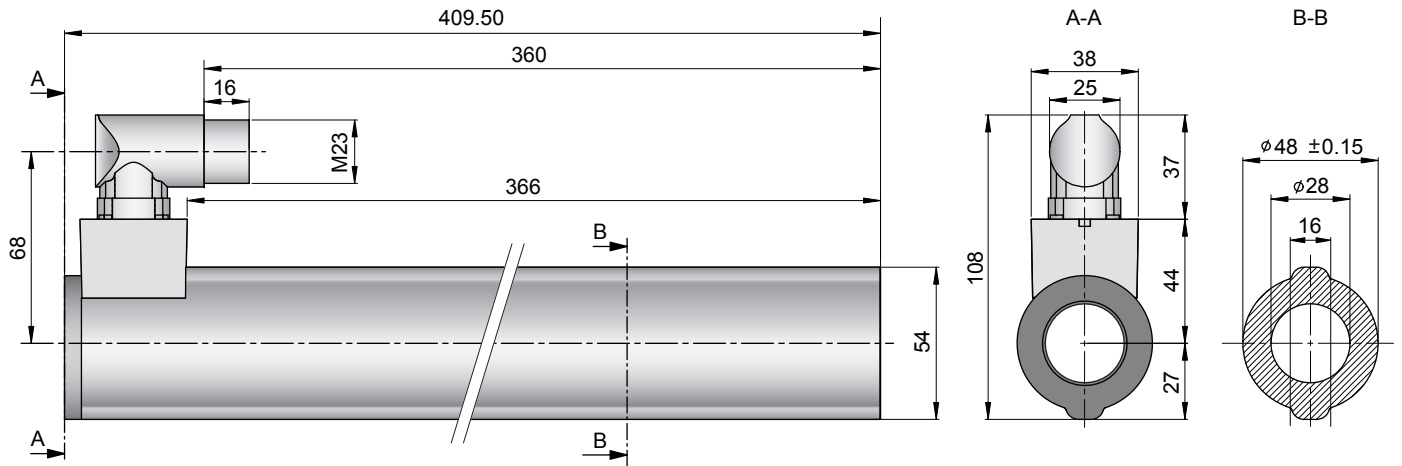

Linear Motor		Stator		Slider	
Type	Art.No	Type	Art. No.	Type	Art. No.
P01-48x360F/1560x1710-C	-->	PS01-48x360F-C	0150-1269	& PL01-28x2000/1920	0150-1396

Slider

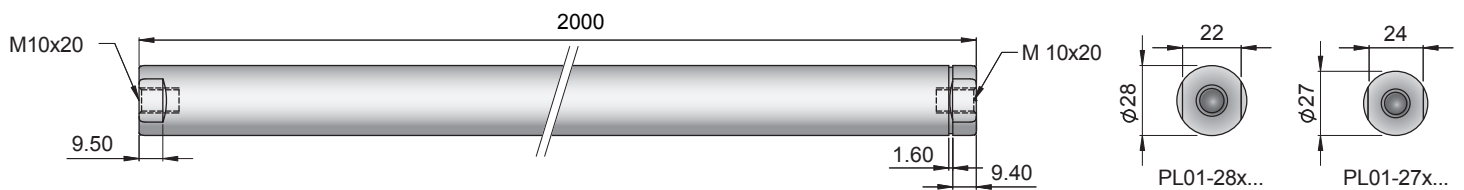

Standard Type	Slider Standard	PL01-28x2000/1920	0150-1396
Special Sliders	Heavy Duty Slider with WC/C-Coating	PL02-28x2000/1920	on request
	Hollow Slider hole diameter 6mm	PL01-28x2000/1920-L	on request
	High Clearance Slider d=27mm	PL01-27x2000/1920	on request

Connectors

Motor connector Wiring

P01-48...-C

Ph 1+	Red	A
Ph 1-	Pink	B
Ph 2+	Blue	C
Ph 2-	Grey	D
+5VDC	White	E
GND	Inner Shield	F
Sine	Yellow	G
Cosine	Green	H
Temp.	Black	L
Shield	Outer Shield	Case

Accessoires

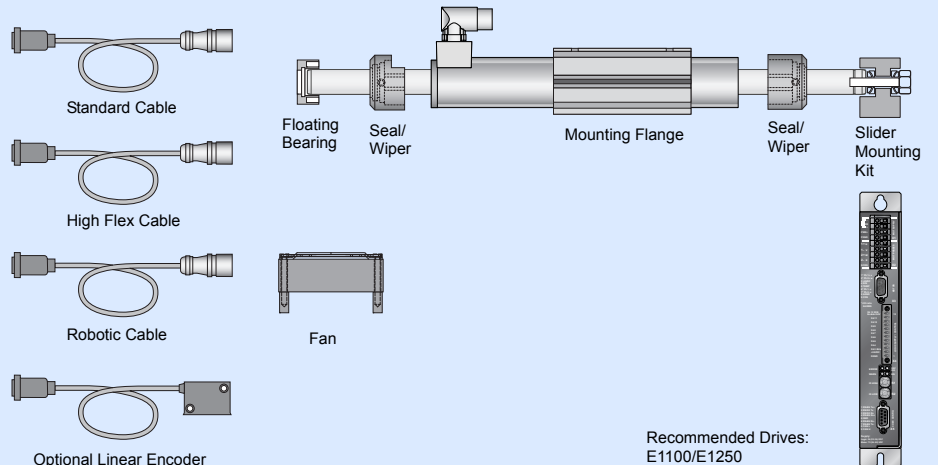

Recommended Drives:
E1100/E1250



Dimensions and ordering information

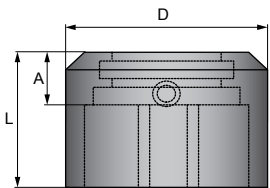

Item	D	L	A	Weight
PA01-48	58mm (2.28in)	32mm (1.26in)	14mm (0.55in)	0.056kg
PA01-48R	58mm (2.28in)	32mm (1.26in)	14mm (0.55in)	0.050kg

PA01-48: 14mm (0.55in)



PA01-48: 14mm (0.55in)

Item	Description	Part Number
PA01-48/27-F	Wiper for PS01-48x... (front wiper for high clearance sliders)	0150-3228
PA01-48/27-R	Wiper for PS01-48x...(-C rear wiper for high clearance sliders)	0150-3229
PA01-48/28-F	Wiper for PS01-48x... (front wiper)	0150-3127
PA01-48/28-R	Wiper for PS01-48x...(-C rear wiper)	0150-3202

PF01-48x346

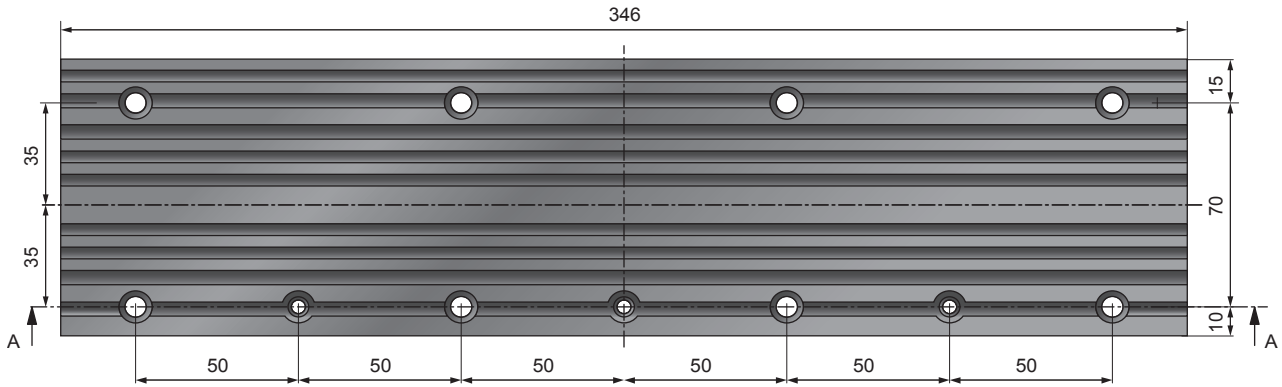

Max. torque for clamp plate screws: 12Nm

Sliding block M6
Part Number 0150-3245

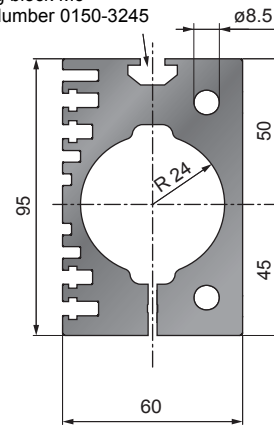
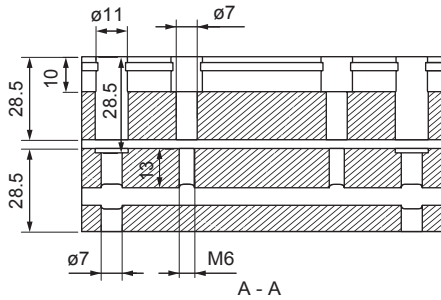

Item	Description	L [mm]	B [mm]	Weight [g]	Part Number
PF01-48x346	Flange 48x346 mm	346	85	2840	0150-2145

Optional Fan for PF01-48

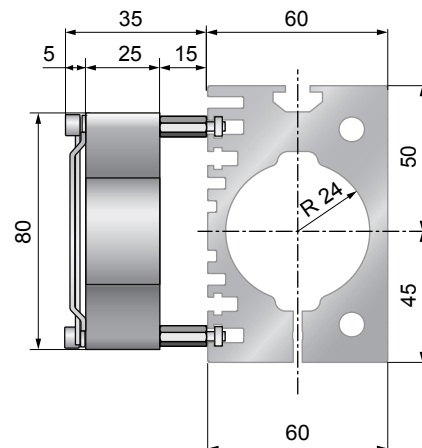
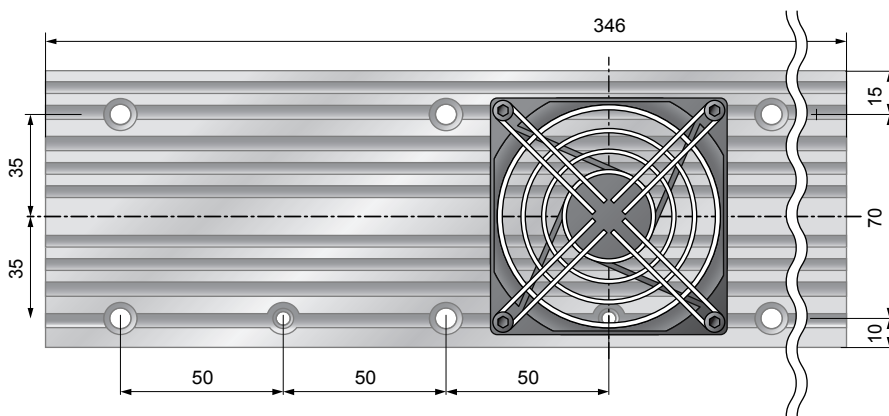

Fan supply:
24VDC, 120mA

Air flow:
80m³/h

Item	Description	Part Number
HV01-37/48	Fan kit for H01-48, B01-48 and PF01-48	0150-5051

HIGH PERFORMANCE LINEAR MOTORS

+70% Continuous Force +50% Peak Force

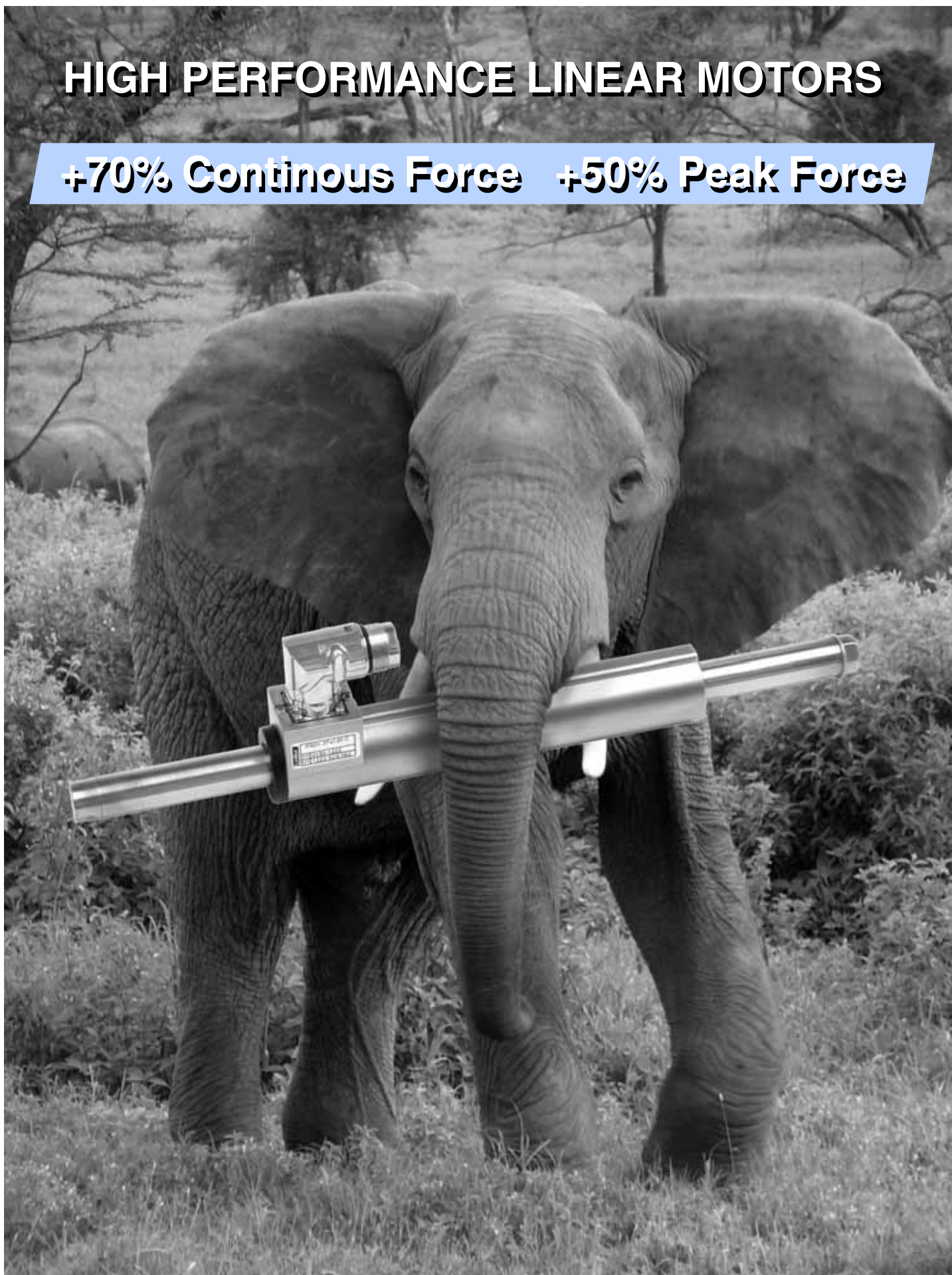

More power in the same package

The new linear motors in the High Performance Series have the same package dimensions as the standard versions, with significantly increased performance. An increase in peak force of 50%, continuous force of 70%, and 20% in speed means nearly double the nominal performance.



Double the nominal performance

The increased power comes from optimization of the motor windings, the magnet circuit, and heat dissipation. Additionally, in the last few years, additional advances have been made in magnet materials, so that a great part of the performance increase can be attributed to the use of stronger magnets.

With High Performance motors, the user has nearly double the available power, with only a 10% increase in price.

Mechanical compatibility

The higher performance with the same form factor allows trouble-free increases in performance for existing machines and systems, without needing to rework the mechanical design. Older machines, too, can be upgraded without a problem. Additionally, with the new linear motors, highly dynamic applications can be realized in a small space, which was previously not possible, or only possible with forced cooling.

Dynamics like never before

High Performance linear motors set a new standard for extremely dynamic motions that have previously been obtainable only with mechanical cam disks.

The new High Performance motors are used, for example, in packaging machines, as a drive for flexible high-performance loaders for light products. The linear motor pushes 3 products per second a distance of 220 mm into the packaging. With six loaders running in parallel, this results in a machine performance of over 1000 products per minute.

Peak Force: 67N
Max. Stroke: 100/130/160
200/220/280
350/410/510
690/780

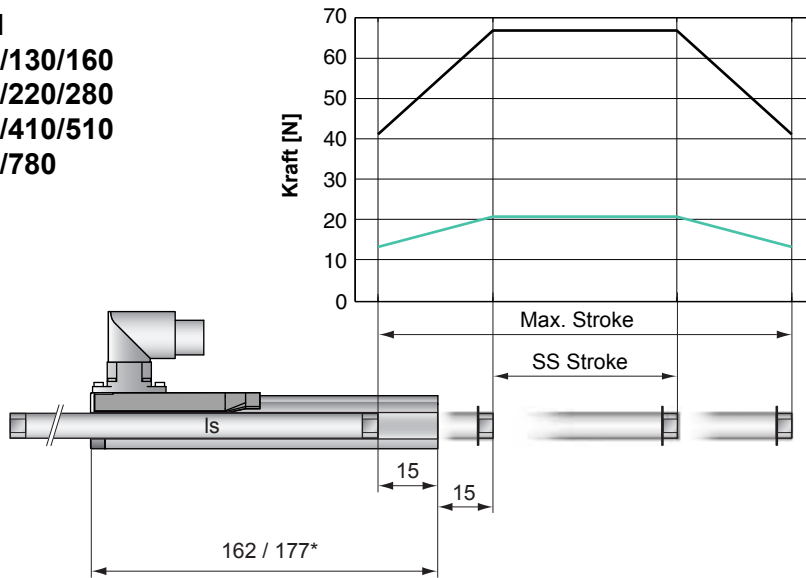

— E1100, 72VDC &
 E1001, 72VDC
 — E100, 48VDC

Dimensions in mm
 *Cable Type

Motor Spezifikation

	P01-	Connector Type						Cable Type					
		23x80F-HP-R						23x80F-HP-R20					
Extended Stroke ES	mm (in)	100	130	160	200	220	280	350	410	510	690	780	
Standard Stroke SS	mm (in)	40	70	100	140	160	220	290	350	450	630	720	
Peak Force E1100 / E1001	N (lbf)							67 (15.1)					
Peak Force E100	N (lbf)							21 (4.7)					
Cont. Force	N (lbf)							15 (3.5)					
Cont. Force Fan cooling	N (lbf)							25 (5.6)					
Border Force	%							63					
Force Constant	N/A (lbf/A)							9 (2.0)					
Max. Current @ 72VDC	A							7.5					
Max. Current @ 48VDC	A							7.5					
Max. Velocity @ 72VDC	m/s (in/s)							7.3 (287)					
Max. Velocity @ 48VDC	m/s (in/s)							4.9 (193)					
Phase Resis. 25/110 °C	Ohm							4.2/5.5					
Phase Inductance	mH							0.6					
Thermal Resistance	°K/W							5.6					
Thermal Time Const.	sec							1600					
Stator Diameter	mm (in)							23 (0.91)					
Stator Length	mm (in)							162/177* (6.38/6.97*)					
Stator Mass	g (lb)							265 (0.58)					
Slider Diameter	mm (in)							12 (0.47)					
Slider Length	mm (in)	170	200	230	270	290	350	420	480	580	760	850	
Slider Mass	g (lb)	125	150	175	210	230	280	340	390	475	625	700	
Position Repeatability	mm (in)							±0.05 (±0.0020)					
Linearity	%							±0.1					
Repeatability with EPS	mm (in)							±0.01 (±0.0004)					
Linearity with EPS	mm (in)							±0.01 (±0.0004)					

PS01-23x80F-HP-R

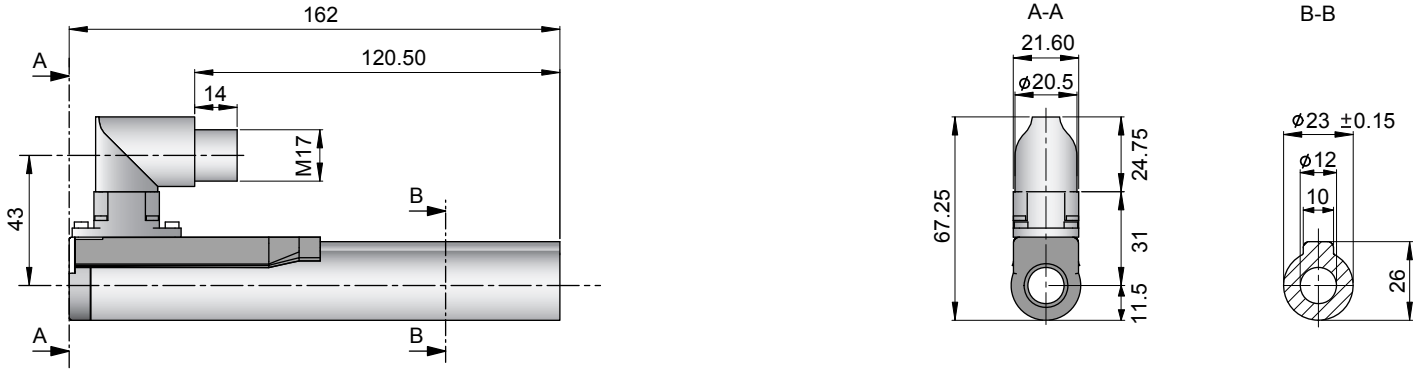

PS01-23x80F-HP-R20

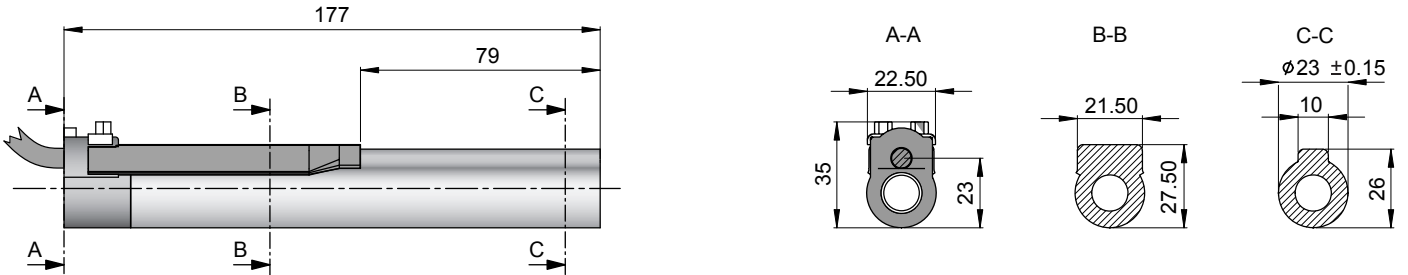

PL01-12x.../...-HP

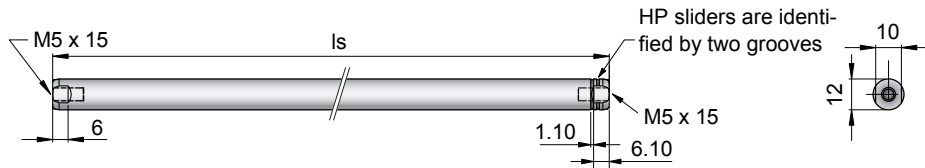

ls	170mm	200mm	230mm
	270mm	290mm	350mm
	420mm	480mm	580mm
	760mm	850mm	

Linear Motor	Art. Nr.	Stator	Art. No.	Slider	Art No.
P01-23x80F/40x100-HP	-->			& PL01-12x170/130-HP	0150-1529
P01-23x80F/70x130-HP	-->			& PL01-12x200/160-HP	0150-1518
P01-23x80F/100x160-HP	-->			& PL01-12x230/190-HP	0150-1519
P01-23x80F/140x200-HP	-->			& PL01-12x270/230-HP	0150-1520
P01-23x80F/160x220-HP	-->	PS01-23x80F-HP-R	0150-1259	& PL01-12x290/250-HP	0150-1521
P01-23x80F/220x280-HP	-->	PS01-23x80F-HP-R20	0150-1260	& PL01-12x350/310-HP	0150-1522
P01-23x80F/290x350-HP	-->			& PL01-12x420/380-HP	0150-1523
P01-23x80F/350x410-HP	-->			& PL01-12x480/440-HP	0150-1524
P01-23x80F/450x510-HP	-->			& PL01-12x580/540-HP	0150-1525
P01-23x80F/630x690-HP	-->			& PL01-12x760/720-HP	0150-1526
P01-23x80F/720x780-HP	-->			& PL01-12x850/810-HP	0150-1527

Connectors

Motor Connector Wiring

Cable Length:
P01-23x80...-HP-R20 0.2m

Ph 1+	red	1
Ph 1-	pink	2
Ph 2+	blue	3
Ph 2-	gray	4
+5VDC	white	A
GND	inner Shield	B
Sine	yellow	C
Cosine	green	D
Temp.	black	E
Shield	outer Shield	Case

Accessoires

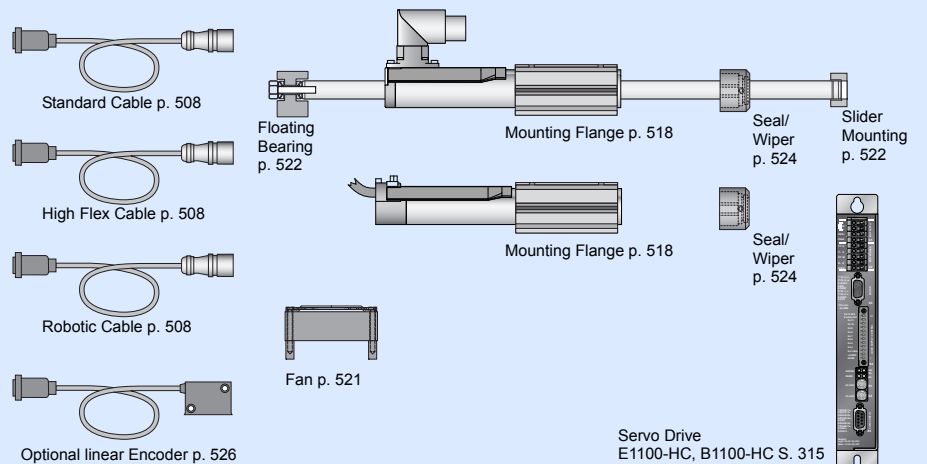

Peak Force: 137N
Max. Stroke: 160/200/220
280/350/410
510/690/780

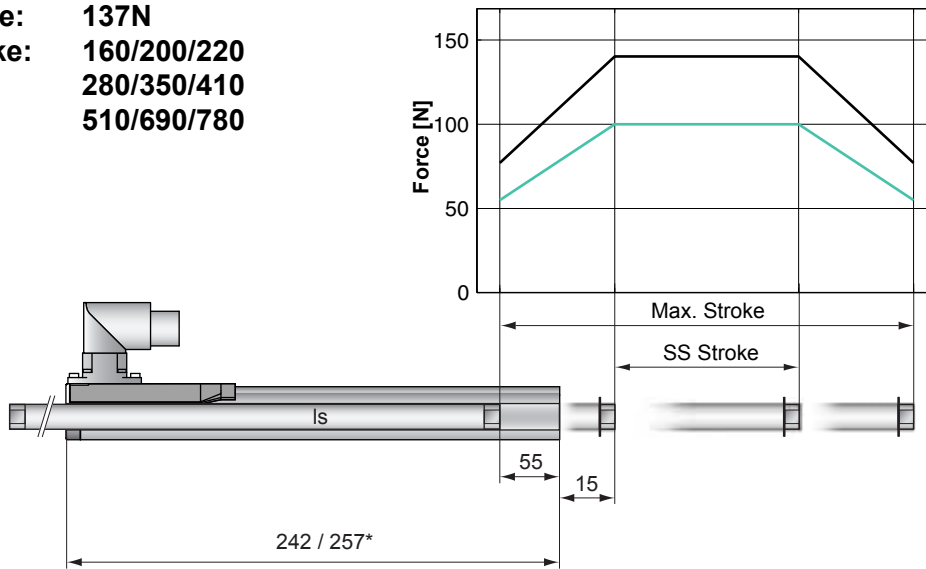

— E1100HC, 72VDC
 — E1100, 72VDC & E1001, 72VDC

Dimensions in mm
 *Cable Type

Motor Specification

	P01-	Connector Type					Cable Type				
		23x160H-HP-R					23x160H-HP-R20				
Extended Stroke ES	mm (in)	160	200	220	280	350	410	510	690	780	
Standard Stroke SS	mm (in)	20	60	80	140	210	270	370	550	640	
Peak Force E1100 - HC	N (lbf)						137 (30.8)				
Peak Force E1100 / E1001	N (lbf)						100 (22.5)				
Cont. Force	N (lbf)						31 (7.0)				
Cont. Force Fan cooling	N (lbf)						48 (10.7)				
Border Force	%						56				
Force Constant	N/A (lbf/A)						12.5 (2.81)				
Max. Current @ 72VDC	A						11				
Max. Current @ 48VDC	A						10				
Max. Velocity @ 72VDC	m/s (in/s)						5.3 (208)				
Max. Velocity @ 48VDC	m/s (in/s)						3.5 (138)				
Phase Resist. 25/80 °C	Ohm						3.8/5.1				
Phase Inductance	mH						0.54				
Thermal Resistance	°K/W						2.7				
Thermal Time Const.	sec						1300				
Stator Diameter	mm (in)						23 (0.91)				
Stator Length	mm (in)						242/257* (9.53/10.12*)				
Stator Mass	g (lb)						450 (0.99)				
Slider Diameter	mm (in)						12 (0.47)				
Slider Length	mm (in)	230	270	290	350	420	480	580	760	850	
Slider Mass	g (lb)	175	210	230	280	340	390	475	625	700	
Position Repeatability	mm (in)						±0.05 (±0.0020)				
Linearity	%						±0.1				
Repeatability with EPS	mm (in)						±0.01 (±0.0004)				
Linearity with EPS	mm (in)						±0.01 (±0.0004)				

PS01-23x160H-HP-R

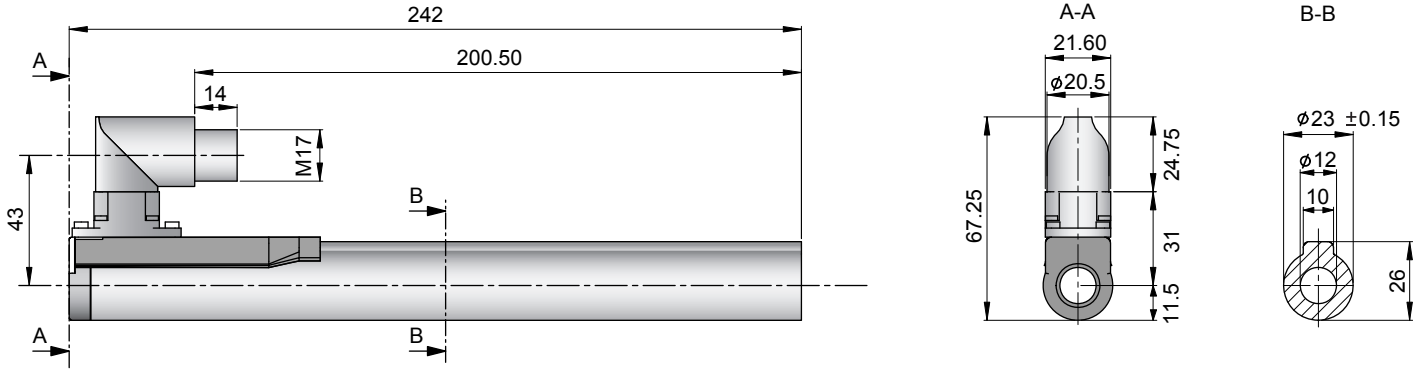

PS01-23x160H-HP-R20

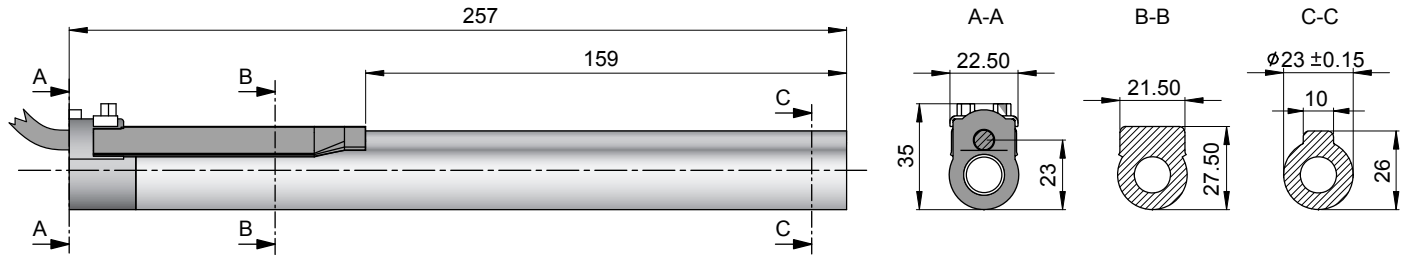

PL01-12x.../...-HP

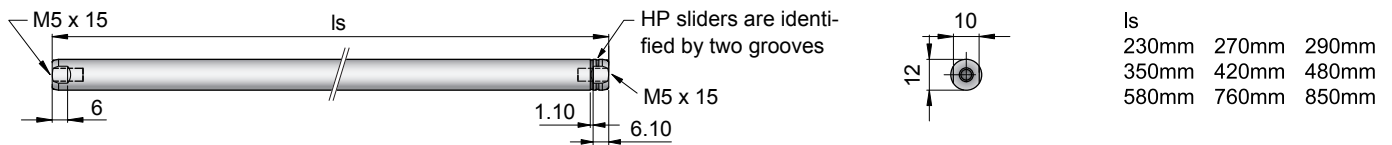

Linear Motor	Stator	Slider	
Type	Art. Nr.	Type	Art. No.
P01-23x160H/20x160-HP	-->	& PL01-12x230/190-HP	0150-1519
P01-23x160H/60x200-HP	-->	& PL01-12x270/230-HP	0150-1520
P01-23x160H/80x220-HP	-->	& PL01-12x290/250-HP	0150-1521
P01-23x160H/140x280-HP	--> PS01-23x160H-HP-R	& PL01-12x350/310-HP	0150-1522
P01-23x160H/210x350-HP	--> PS01-23x160H-HP-R20	& PL01-12x420/380-HP	0150-1523
P01-23x160H/270x410-HP	-->	& PL01-12x480/440-HP	0150-1524
P01-23x160H/370x510-HP	-->	& PL01-12x580/540-HP	0150-1525
P01-23x160H/550x690-HP	-->	& PL01-12x760/720-HP	0150-1526
P01-23x160H/640x780-HP	-->	& PL01-12x850/810-HP	0150-1527

Connectors

Motor Connector Wiring

Cable Length:
P01-23x160...-HP-R20 0.2m

Ph 1+	red	1
Ph 1-	pink	2
Ph 2+	blue	3
Ph 2-	gray	4
+5VDC	white	A
GND	inner Shield	B
Sine	yellow	C
Cosine	green	D
Temp.	black	E
Shield	outer Shield	Case

Accessoires

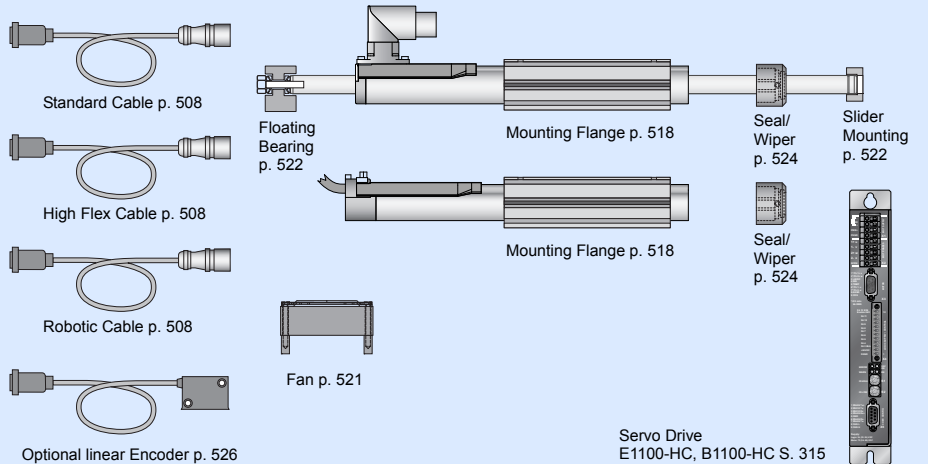

Peak Force: 255N
**Max. Stroke: 120/180/240/280/
 380/480/580/680/
 780/880/1080/
 1280/1480mm**

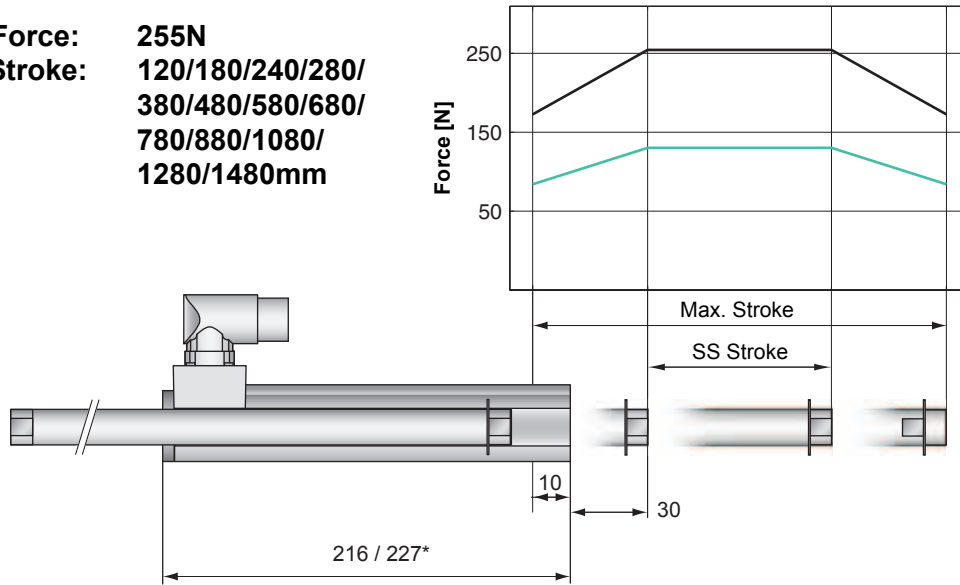

— E1100-HC, 72VDC
 — E1100, 72VDC & E1001, 72VDC

Dimensions in mm
 *Cable Type

Motor Specification

	P01-	Connector Type							Cable Type						
		37x120F-HP-C							37x120F-HP-C20						
Extended Stroke ES	mm (in)	120	180	240	280	380	480	580	680	780	880	1080	1280	1480	
Standard Stroke SS	mm (in)	40	100	160	200	300	400	500	600	700	800	1000	1200	1400	
Peak Force E1100 - HC	N (lbf)								255 (57.3)						
Peak Force E1100 / E1001	N (lbf)								136 (30.6)						
Cont. Force	N (lbf)								51 (11.5)						
Cont. Force Fan cooling	N (lbf)								92 (20.7)						
Border Force	%								67						
Force Constant	N/A (lbf/A)								17 (3.83)						
Max. Current @ 72VDC	A								15						
Max. Current @ 48VDC	A								15						
Max. Velocity @ 72VDC	m/s (in/s)								3.9 (154)						
Max. Velocity @ 48VDC	m/s (in/s)								2.6 (102)						
Phase Resis. 25/110 °C	Ohm								2.35/3.2						
Phase Inductance	mH								1.6						
Thermal Resistance	°K/W								3.2						
Thermal Time Const.	sec								3100						
Stator Diameter	mm (in)								37 (1.46)						
Stator Length	mm (in)								216/227* (8.5/8.94*)						
Stator Mass	g (lb)								740 (1.63)						
Slider Diameter	mm (in)								20 (0.79)						
Slider Length	mm (in)	240	300	360	400	500	600	700	800	900	1000	1200	1400	1600	
Slider Mass	g (lb)	510	650	800	880	1110	1350	1580	1810	2040	2270	2740	3170	3640	
Position Repeatability	mm (in)								±0.05 (±0.0020)						
Linearity	%								±0.1						
Repeatability with EPS	mm (in)								±0.01 (±0.0004)						
Linearity with EPS	mm (in)								±0.01 (±0.0004)						

PS01-37x120F-HP-C

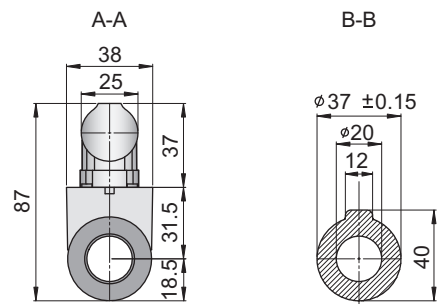
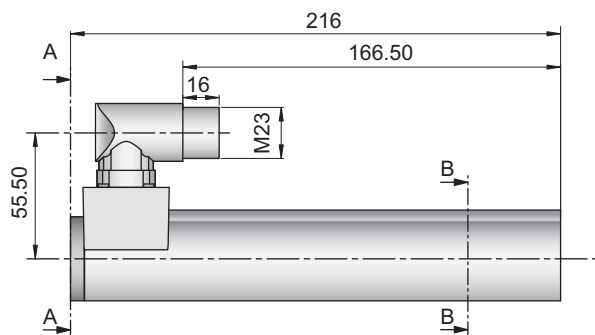

PS01-37x120F-HP-C20

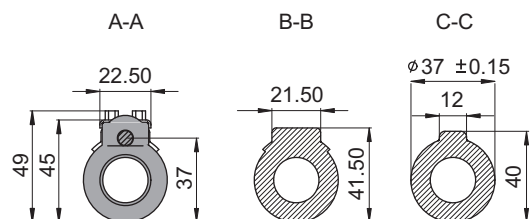
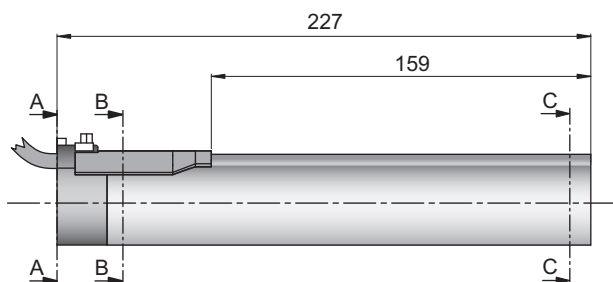

PL01-20x.../...-HP

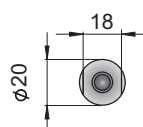
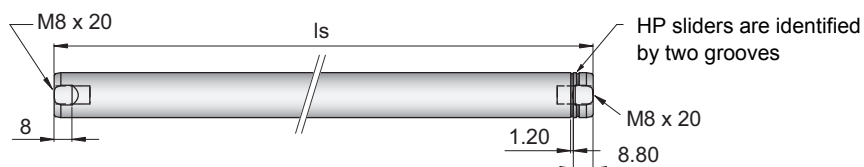

1s	240mm	300mm	360mm
	400mm	500mm	600mm
	700mm	800mm	900mm
	1000mm	1200mm	
	1400mm	1600mm	

Linear Motor	Stator	Slider
Type	Art. Nr.	Type
P01-37x120F/40x120-HP	-->	& PL01-20x240/180-HP
P01-37x120F/100x180-HP	-->	& PL01-20x300/240-HP
P01-37x120F/160x240-HP	-->	& PL01-20x360/300-HP
P01-37x120F/200x280-HP	-->	& PL01-20x400/340-HP
P01-37x120F/300x380-HP	-->	& PL01-20x500/440-HP
P01-37x120F/400x480-HP	--> PS01-37x120F-HP-C	& PL01-20x600/540-HP
P01-37x120F/500x580-HP	--> PS01-37x120F-HP-C20	& PL01-20x700/640-HP
P01-37x120F/600x680-HP	-->	& PL01-20x800/740-HP
P01-37x120F/700x780-HP	-->	& PL01-20x900/840-HP
P01-37x120F/800x880-HP	-->	& PL01-20x1000/940-HP
P01-37x120F/1000x1080-HP	-->	& PL01-20x1200/1140-HP
P01-37x120F/1200x1280-HP	-->	& PL01-20x1400/1340-HP
P01-37x120F/1400x1480-HP	-->	& PL01-20x1600/1540-HP

Connectors

Motor Connector Wiring

Cable Length:
P01-37x120...-HP-C20 0.2m

Ph 1+	red	A
Ph 1-	pink	B
Ph 2+	blue	C
Ph 2-	grey	D
+5VDC	white	E
GND	inner Shield	F
Sine	yellow	G
Cosine	green	H
Temp.	black	L
Shield	outer Shield	Case

Accessoires

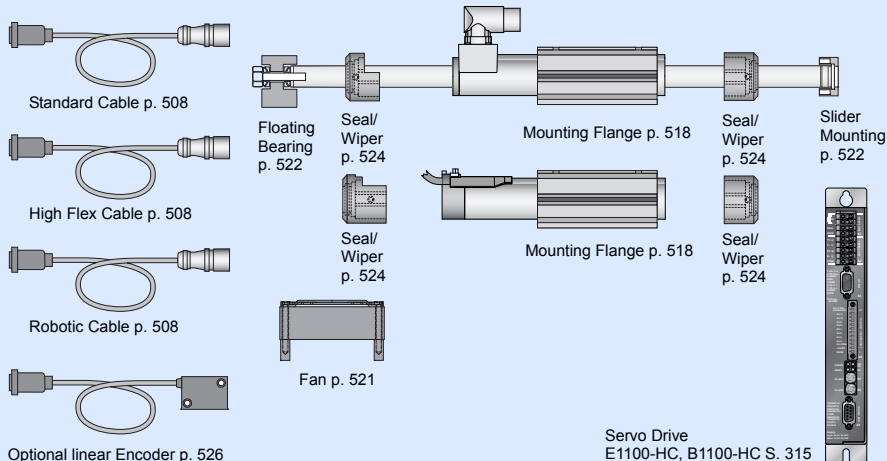

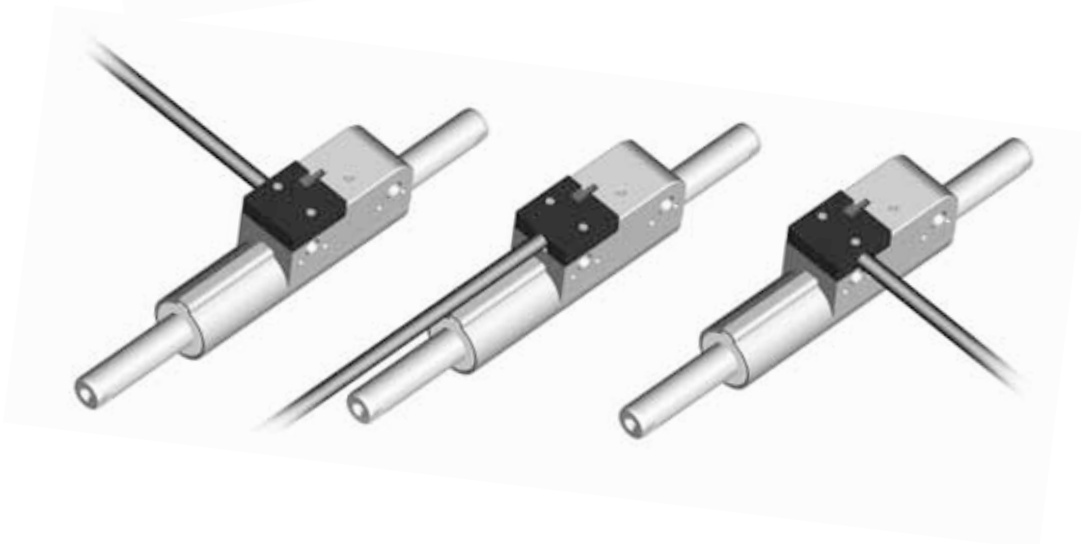
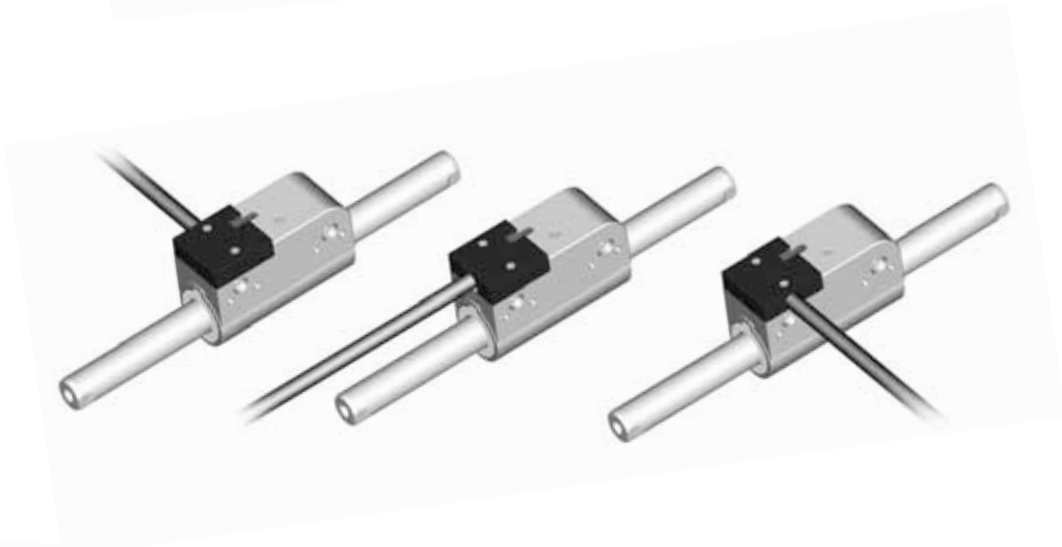

P02-23Sx80/10x50 200

P02-23Sx80/30x90 202

P02-23Sx80/50x110 204

P02-23Sx80/80x140 206

P02-23Sx80/150x210 208

P02-23Sx80/210x270 210

P02-23Sx80/280x340 212

P02-23Sx80/340x400 214

P02-23Sx80/440x500 216

P02-23Sx80/620x680 218

P02-23Sx80/710x770 220



Max. Stroke: 50mm
Peak Force: 39N

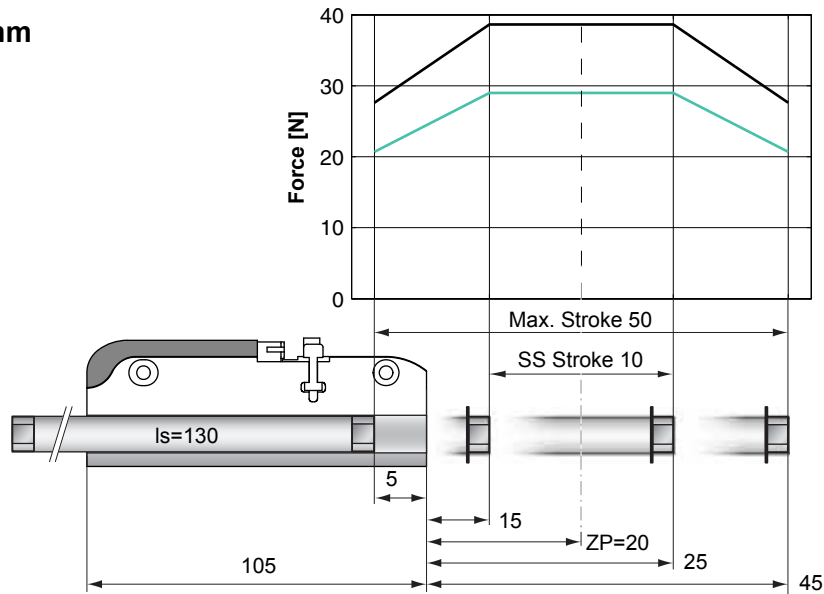

Standard Winding:
 — E1100, 72VDC & E1001, 72VDC
 — E100, 48VDC

Dimensions in mm

Motor Specification

		P02-23Sx80/10x50
Extended Stroke ES	mm (in)	50 (1.97)
Standard Stroke SS	mm (in)	10 (0.39)
Peak Force E1100 / E1001	N (lbf)	39 (8.7)
Peak Force E100	N (lbf)	29 (6.5)
Cont. Force	N (lbf)	8 (1.7)
Cont. Force Fan cooling	N (lbf)	14 (3.2)
Border Force	%	71
Force Constant	N/A (lbf/A)	9.7 (2.17)
Max. Current @ 72VDC	A	4.0
Max. Current @ 48VDC	A	3.8
Max. Velocity @ 72VDC	m/s (in/s)	6.9 (270)
Max. Velocity @ 48VDC	m/s (in/s)	4.6 (180)
Phase Resist. 25/80 °C	Ohm	10.3/12.5
Phase Inductance	mH	1.4
Thermal Resistance	°K/W	7.0
Thermal Time Const.	sec	900
Stator Diameter	mm (in)	23 (0.91)
Stator Length	mm (in)	105 (4.13)
Stator Mass	g (lb)	245 (0.54)
Slider Diameter	mm (in)	12 (0.47)
Slider Length	mm (in)	130 (5.12)
Slider Mass	g (lb)	89 (0.20)
Position Repeatability	mm (in)	±0.05 (±0.0020)
Linearity	%	±0.70
Repeatability with EPS	mm (in)	±0.01 (±0.0004)
Linearity with EPS	mm (in)	±0.01 (±0.0004)

Position-Time Diagram

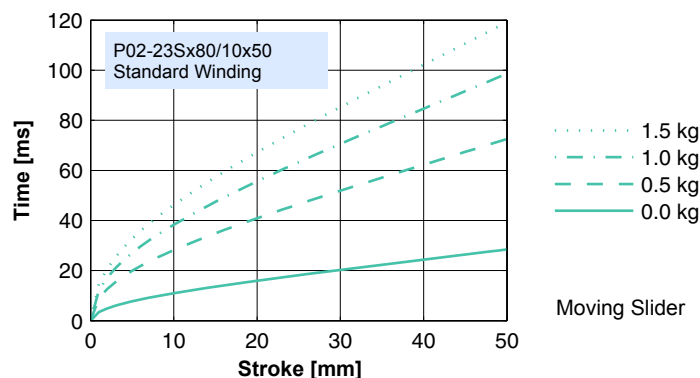

Moving Slider

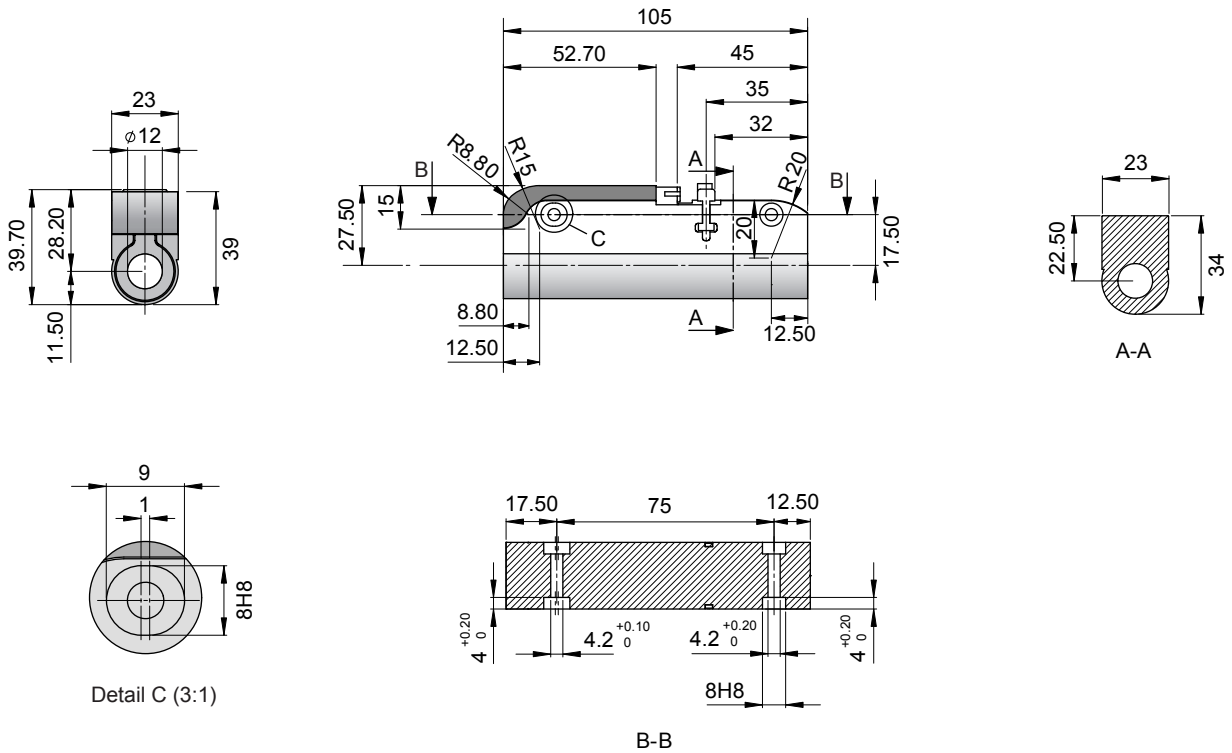

Linear Motor		Stator		Slider	
Type	Art.No	Type	Art. No.	Type	Art No.
P02-23Sx80/10x50	-->	PS02-23Sx80-F	0150-1272	& PL01-12x130/80	0150-1399

Slider

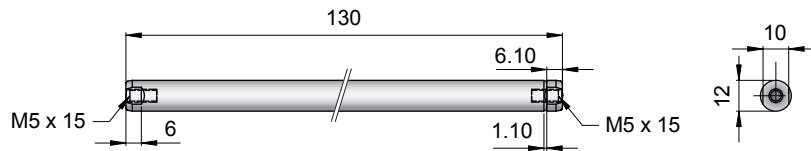

Standard Type	Slider Standard	PL01-12x130/80	0150-1399
Special Sliders	Heavy Duty Slider with WC/C-Coating	PL02-12x130/80	0150-1424
	Hollow Slider hole diameter 4.2mm	PL01-12x130/80-L	0150-1445

Connectors

Motor connector Wiring

Pin 1	Phase 2-
Pin 2	Phase 2-
Pin 3	Phase 1-
Pin 4	Phase 1-
Pin 5	+5V
Pin 6	Temp
Pin 7	GND
Pin 8	Cosine
Pin 9	Sine
Pin 10	Phase 2+
Pin 11	Phase 2+
Pin 12	Phase 1+
Pin 13	Phase 1+

Accessoires

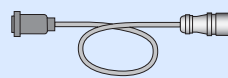

Standard Cable p. 508

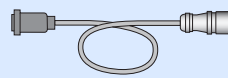

High Flex Cable p. 508

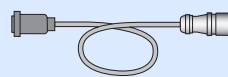

Robotic Cable p. 508



Servo Drive:
E100, E1001, E1100, B1100 p. 315

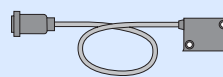

Optional Linear Encoder p. 526

Max. Stroke: 90mm
Peak Force: 44N

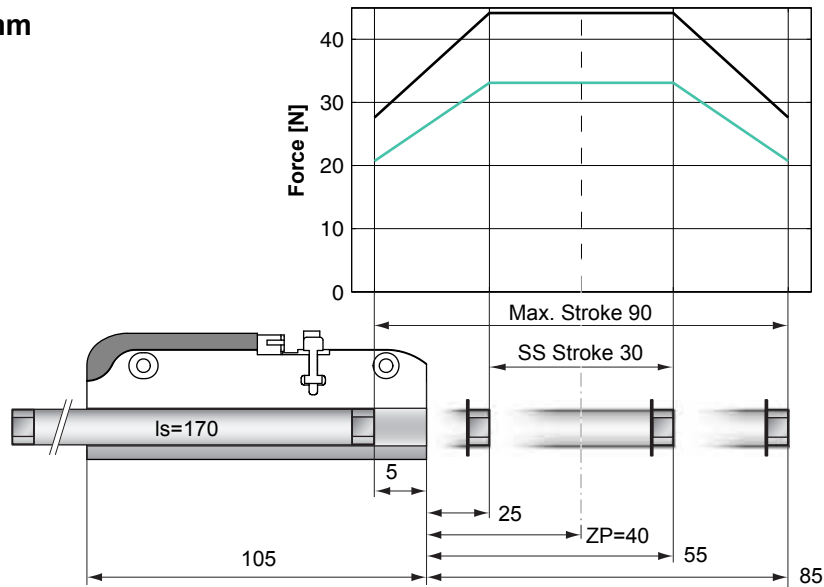

Standard Winding:
 — E1100, 72VDC &
 E1001, 72VDC
 — E100, 48VDC

Dimensions in mm

Motor Specification

		P02-23Sx80/30x90
Extended Stroke ES	mm (in)	90 (3.54)
Standard Stroke SS	mm (in)	30 (1.18)
Peak Force E1100 / E1001	N (lbf)	44 (9.9)
Peak Force E100	N (lbf)	33 (7.4)
Cont. Force	N (lbf)	9 (2.0)
Cont. Force Fan cooling	N (lbf)	16 (3.7)
Border Force	%	63
Force Constant	N/A (lbf/A)	11.0 (2.48)
Max. Current @ 72VDC	A	4.0
Max. Current @ 48VDC	A	3.8
Max. Velocity @ 72VDC	m/s (in/s)	6.0 (236)
Max. Velocity @ 48VDC	m/s (in/s)	4.0 (157)
Phase Resist. 25/80 °C	Ohm	10.3/12.5
Phase Inductance	mH	1.4
Thermal Resistance	°K/W	7.0
Thermal Time Const.	sec	900
Stator Diameter	mm (in)	23 (0.91)
Stator Length	mm (in)	105 (4.13)
Stator Mass	g (lb)	245 (0.54)
Slider Diameter	mm (in)	12 (0.47)
Slider Length	mm (in)	170 (6.69)
Slider Mass	g (lb)	118 (0.26)
Position Repeatability	mm (in)	±0.05 (±0.0020)
Linearity	%	±0.45
Repeatability with EPS	mm (in)	±0.01 (±0.0004)
Linearity with EPS	mm (in)	±0.01 (±0.0004)

Position-Time Diagram

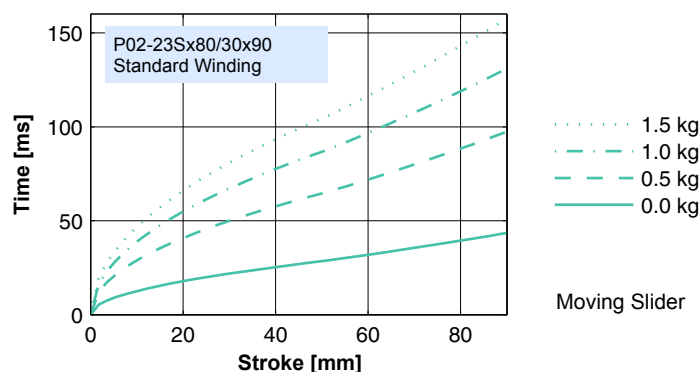

Stator

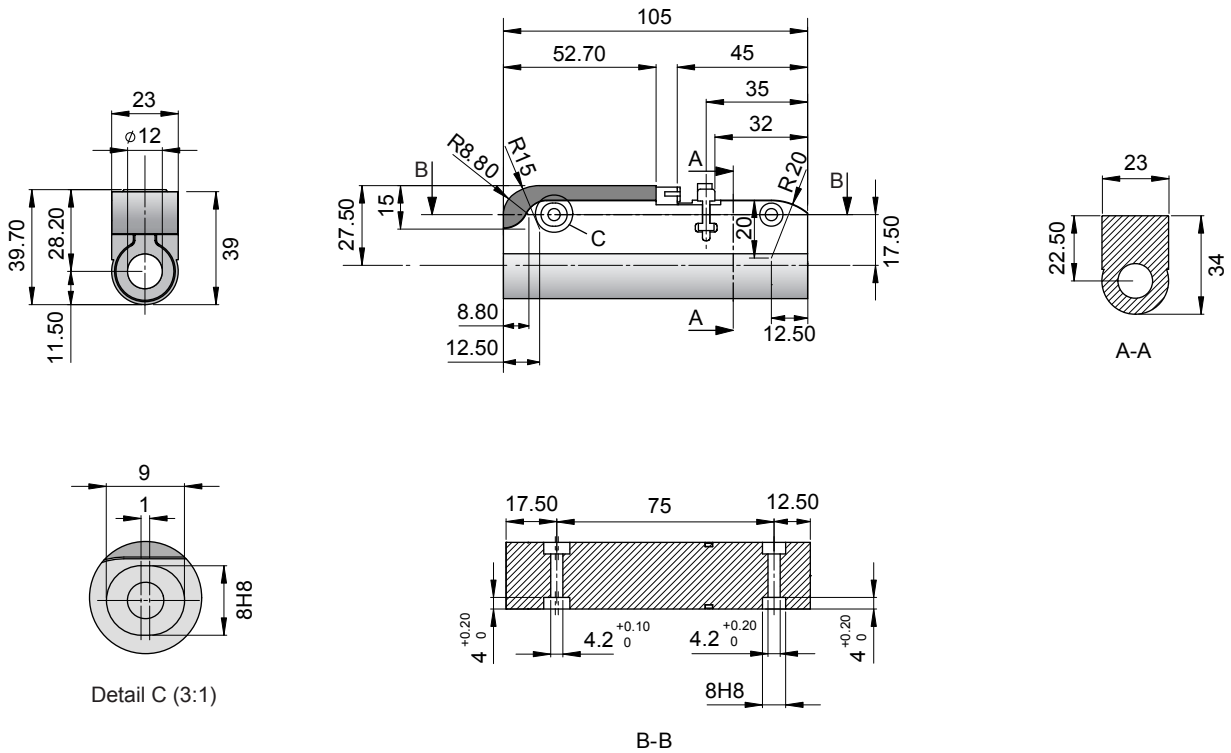

Linear Motor		Stator		Slider	
Type	Art.No	Type	Art. No.	Type	Art No.
P02-23Sx80/30x90	-->	PS02-23Sx80-F	0150-1272	& PL01-12x170/120	0150-1301

Slider

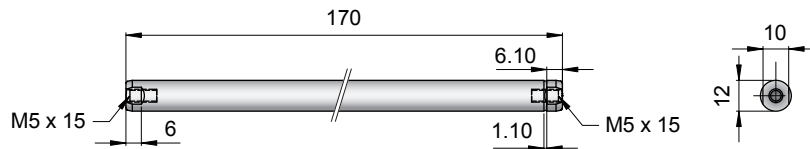

Standard Type	Slider Standard	PL01-12x170/120	0150-1301
Special Sliders	Heavy Duty Slider with WC/C-Coating	PL02-12x170/120	0150-1303
	Hollow Slider hole diameter 4.2mm	PL01-12x170/120-L	0150-1375

Connectors

Motor connector Wiring

Pin 1	Phase 2-
Pin 2	Phase 2-
Pin 3	Phase 1-
Pin 4	Phase 1-
Pin 5	+5V
Pin 6	Temp
Pin 7	GND
Pin 8	Cosine
Pin 9	Sine
Pin 10	Phase 2+
Pin 11	Phase 2+
Pin 12	Phase 1+
Pin 13	Phase 1+

Accessoires

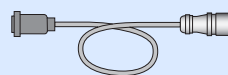

Standard Cable p. 508

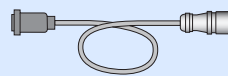

High Flex Cable p. 508

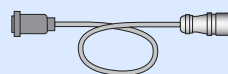

Robotic Cable p. 508



Servo Drive:
E100, E1001, E1100, B1100 p. 315

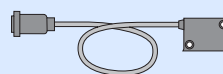

Optional Linear Encoder p. 526

Max. Stroke: 110mm
Peak Force: 44N

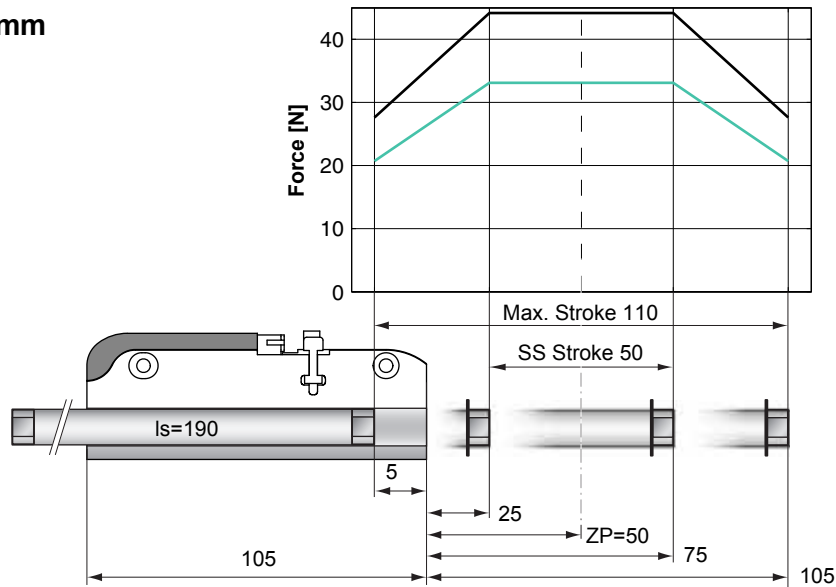

Standard Winding:
 — E1100, 72VDC & E1001, 72VDC
 — E100, 48VDC

Dimensions in mm

Motor Specification

		P02-23Sx80/50x110
Extended Stroke ES	mm (in)	110 (4.33)
Standard Stroke SS	mm (in)	50 (1.97)
Peak Force E1100 / E1001	N (lbf)	44 (9.9)
Peak Force E100	N (lbf)	33 (7.4)
Cont. Force	N (lbf)	9 (2.0)
Cont. Force Fan cooling	N (lbf)	16 (3.7)
Border Force	%	63
Force Constant	N/A (lbf/A)	11.0 (2.48)
Max. Current @ 72VDC	A	4.0
Max. Current @ 48VDC	A	3.8
Max. Velocity @ 72VDC	m/s (in/s)	6.0 (236)
Max. Velocity @ 48VDC	m/s (in/s)	4.0 (157)
Phase Resist. 25/80 °C	Ohm	10.3/12.5
Phase Inductance	mH	1.4
Thermal Resistance	°K/W	7.0
Thermal Time Const.	sec	900
Stator Diameter	mm (in)	23 (0.91)
Stator Length	mm (in)	105 (4.13)
Stator Mass	g (lb)	245 (0.54)
Slider Diameter	mm (in)	12 (0.47)
Slider Length	mm (in)	190 (7.48)
Slider Mass	g (lb)	135 (0.30)
Position Repeatability	mm (in)	±0.05 (±0.0020)
Linearity	%	±0.40
Repeatability with EPS	mm (in)	±0.01 (±0.0004)
Linearity with EPS	mm (in)	±0.01 (±0.0004)

Position-Time Diagram

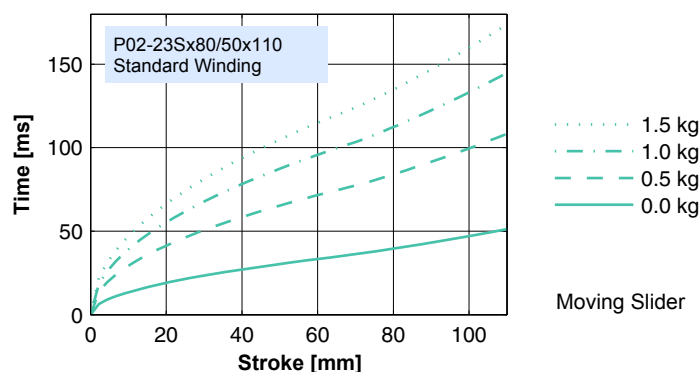

Moving Slider

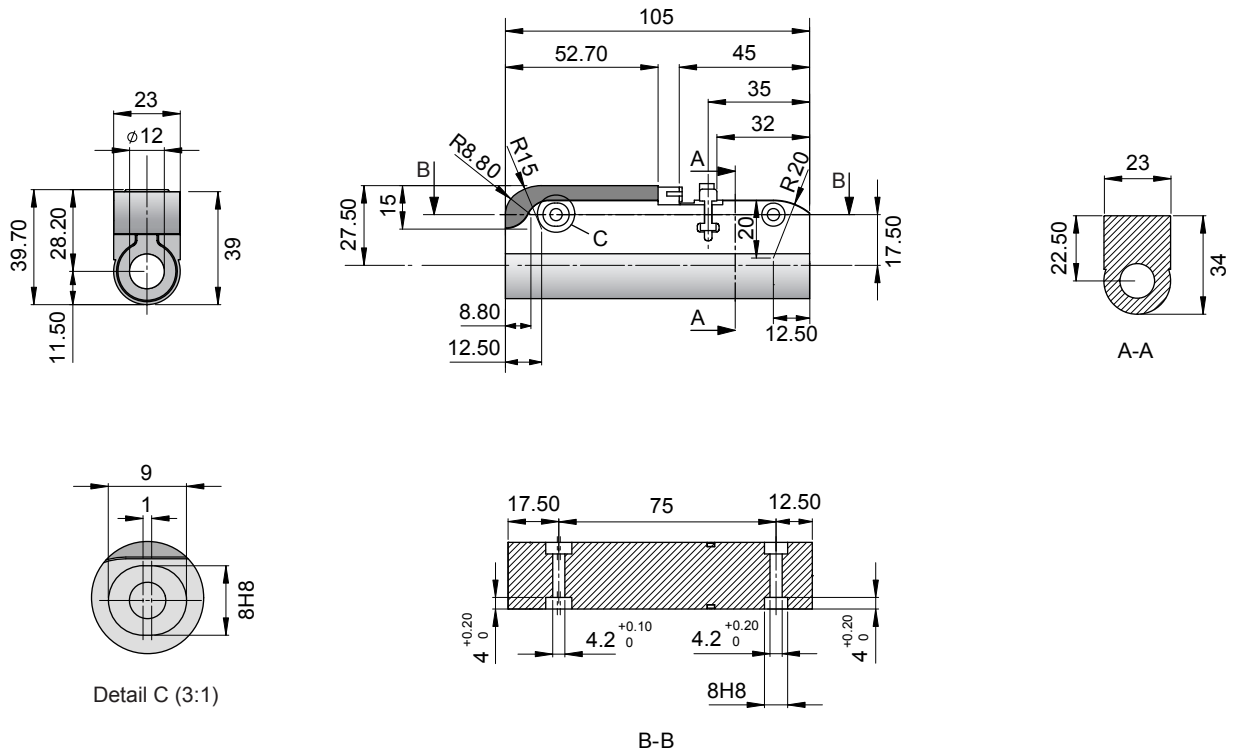

Linear Motor		Stator		Slider	
Type	Art.No	Type	Art. No.	Type	Art No.
P02-23Sx80/50x110	-->	PS02-23Sx80-F	0150-1272	& PL01-12x190/140	0150-1302

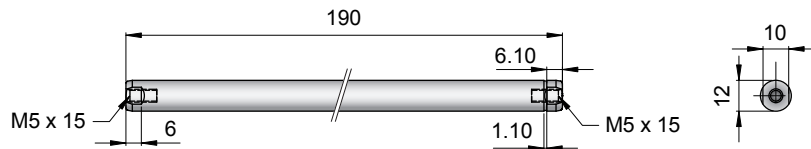

Standard Type	Slider Standard	PL01-12x190/140	0150-1302
Special Sliders	Heavy Duty Slider with WC/C-Coating	PL02-12x190/140	0150-1304
	Hollow Slider hole diameter 4.2mm	PL01-12x190/140-L	0150-1478

Motor connector Wiring

Pin 1	Phase 2-
Pin 2	Phase 2-
Pin 3	Phase 1-
Pin 4	Phase 1-
Pin 5	+5V
Pin 6	Temp
Pin 7	GND
Pin 8	Cosine
Pin 9	Sine
Pin 10	Phase 2+
Pin 11	Phase 2+
Pin 12	Phase 1+
Pin 13	Phase 1+

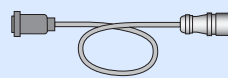

Standard Cable p. 508

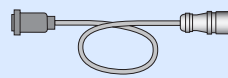

High Flex Cable p. 508

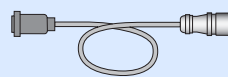

Robotic Cable p. 508



Servo Drive: E100, E1001, E1100, B1100 p. 315

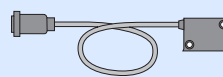

Optional Linear Encoder p. 526

Max. Stroke: 140mm
Peak Force: 44N

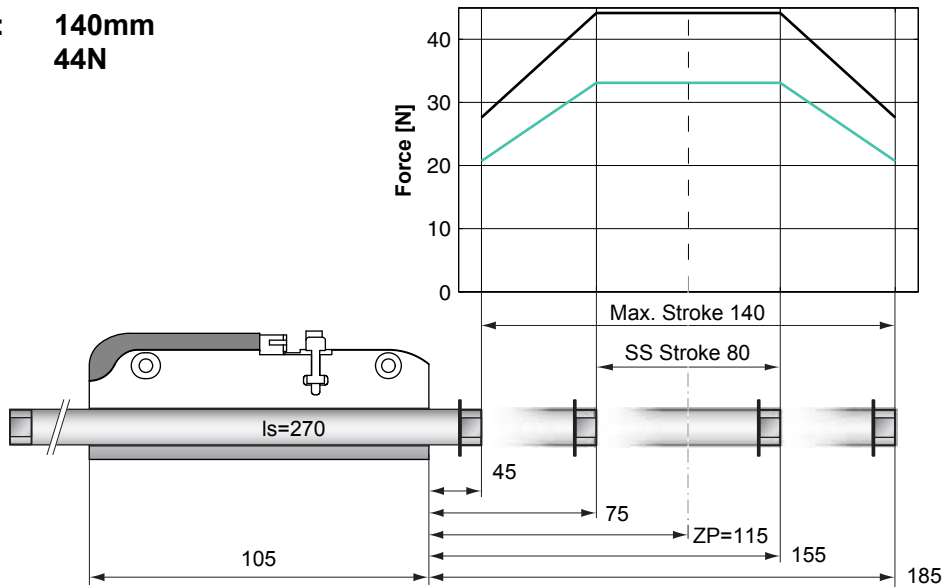

Standard Winding:
 — E1100, 72VDC & E1001, 72VDC
 — E100, 48VDC

Dimensions in mm

Motor Specification

		P02-23Sx80/80x140
Extended Stroke ES	mm (in)	140 (5.51)
Standard Stroke SS	mm (in)	80 (3.15)
Peak Force E1100 / E1001	N (lbf)	44 (9.9)
Peak Force E100	N (lbf)	33 (7.4)
Cont. Force	N (lbf)	9 (2.0)
Cont. Force Fan cooling	N (lbf)	16 (3.7)
Border Force	%	63
Force Constant	N/A (lbf/A)	11.0 (2.48)
Max. Current @ 72VDC	A	4.0
Max. Current @ 48VDC	A	3.8
Max. Velocity @ 72VDC	m/s (in/s)	6.0 (236)
Max. Velocity @ 48VDC	m/s (in/s)	4.0 (157)
Phase Resist. 25/80 °C	Ohm	10.3/12.5
Phase Inductance	mH	1.4
Thermal Resistance	°K/W	7.0
Thermal Time Const.	sec	900
Stator Diameter	mm (in)	23 (0.91)
Stator Length	mm (in)	105 (4.13)
Stator Mass	g (lb)	245 (0.54)
Slider Diameter	mm (in)	12 (0.47)
Slider Length	mm (in)	270 (10.63)
Slider Mass	g (lb)	171 (0.38)
Position Repeatability	mm (in)	±0.05 (±0.0020)
Linearity	%	±0.35
Repeatability with EPS	mm (in)	±0.01 (±0.0004)
Linearity with EPS	mm (in)	±0.01 (±0.0004)

Position-Time Diagram

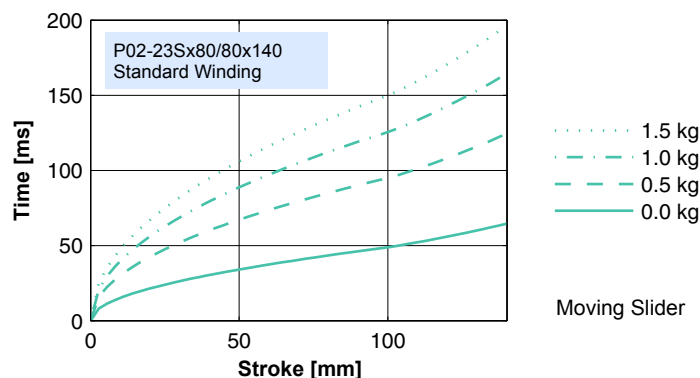

Stator

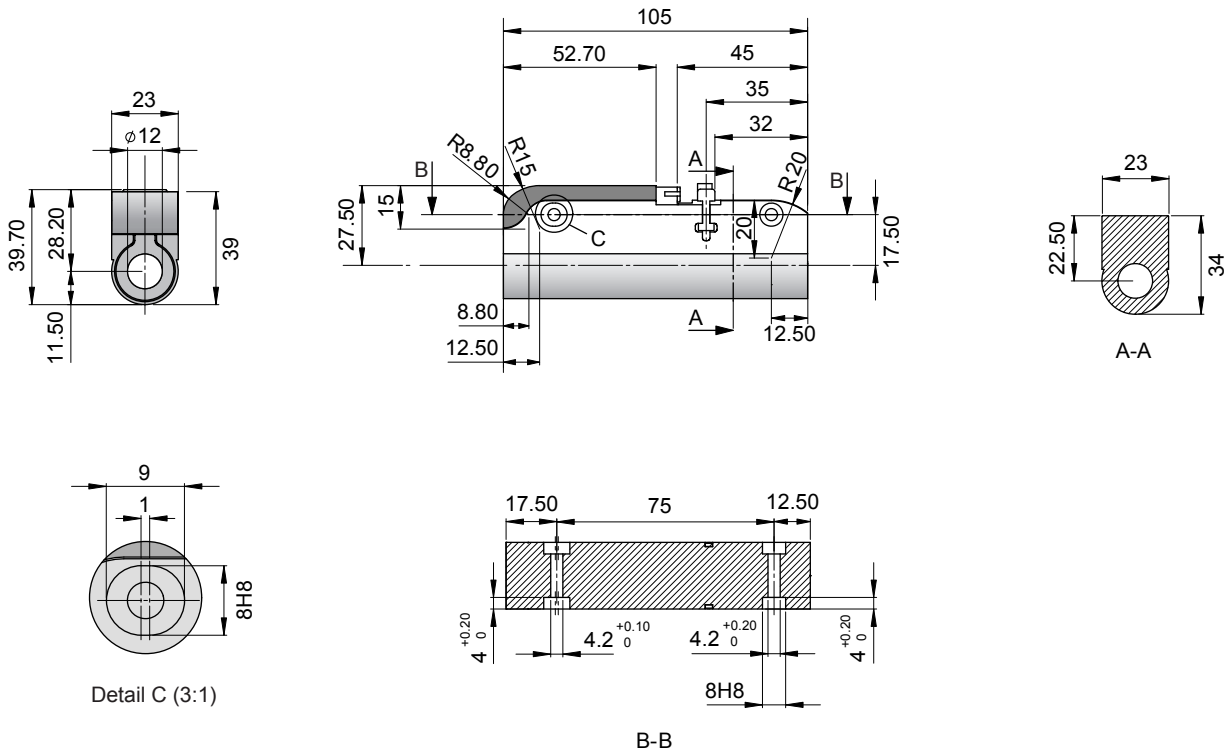

Linear Motor		Stator		Slider	
Type	Art.No	Type	Art. No.	Type	Art No.
P02-23Sx80/80x140	-->	PS02-23Sx80-F	0150-1272	& PL01-12x270/170	0150-1307

Slider

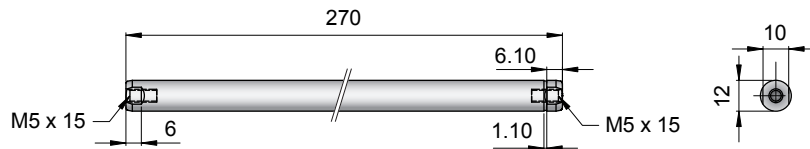

Standard Type	Slider Standard	PL01-12x270/170	0150-1307
Special Sliders	Heavy Duty Slider with WC/C-Coating	PL02-12x270/170	0150-1310
	Hollow Slider hole diameter 4.2mm	PL01-12x270/170-L	0150-1393

Connectors

Motor connector Wiring

Pin 1	Phase 2-
Pin 2	Phase 2-
Pin 3	Phase 1-
Pin 4	Phase 1-
Pin 5	+5V
Pin 6	Temp
Pin 7	GND
Pin 8	Cosine
Pin 9	Sine
Pin 10	Phase 2+
Pin 11	Phase 2+
Pin 12	Phase 1+
Pin 13	Phase 1+

Accessoires

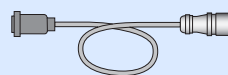

Standard Cable p. 508

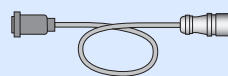

High Flex Cable p. 508

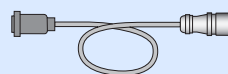

Robotic Cable p. 508



Servo Drive:
E100, E1001, E1100, B1100 p. 315

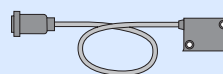

Optional Linear Encoder p. 526

Max. Stroke: 210mm
Peak Force: 44N

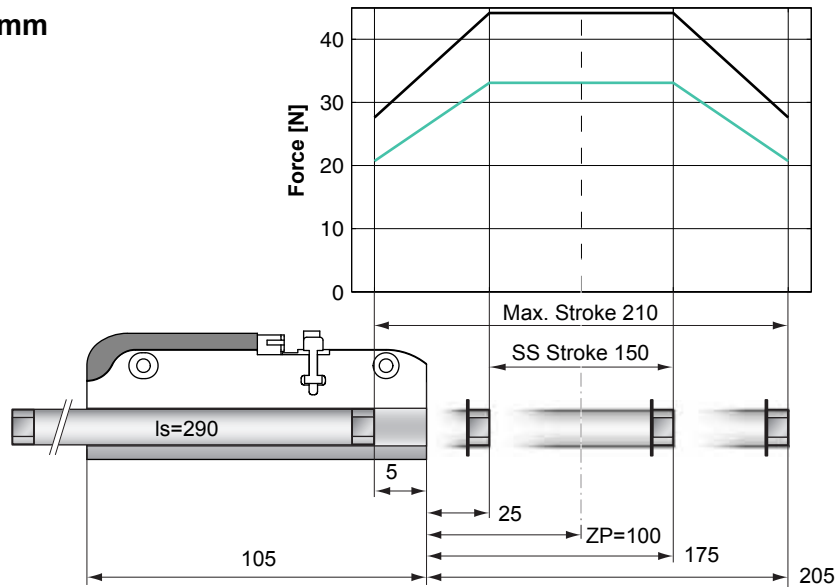

Standard Winding:
 — E1100, 72VDC & E1001, 72VDC
 — E100, 48VDC

Dimensions in mm

Motor Specification

		P02-23Sx80/150x210
Extended Stroke ES	mm (in)	210 (8.27)
Standard Stroke SS	mm (in)	150 (5.91)
Peak Force E1100 / E1001	N (lbf)	44 (9.9)
Peak Force E100	N (lbf)	33 (7.4)
Cont. Force	N (lbf)	9 (2.0)
Cont. Force Fan cooling	N (lbf)	16 (3.7)
Border Force	%	63
Force Constant	N/A (lbf/A)	11.0 (2.48)
Max. Current @ 72VDC	A	4.0
Max. Current @ 48VDC	A	3.8
Max. Velocity @ 72VDC	m/s (in/s)	6.0 (236)
Max. Velocity @ 48VDC	m/s (in/s)	4.0 (157)
Phase Resist. 25/80 °C	Ohm	10.3/12.5
Phase Inductance	mH	1.4
Thermal Resistance	°K/W	7.0
Thermal Time Const.	sec	900
Stator Diameter	mm (in)	23 (0.91)
Stator Length	mm (in)	105 (4.13)
Stator Mass	g (lb)	245 (0.54)
Slider Diameter	mm (in)	12 (0.47)
Slider Length	mm (in)	290 (11.42)
Slider Mass	g (lb)	220 (0.49)
Position Repeatability	mm (in)	±0.05 (±0.0020)
Linearity	%	±0.30
Repeatability with EPS	mm (in)	±0.01 (±0.0004)
Linearity with EPS	mm (in)	±0.01 (±0.0004)

Position-Time Diagram

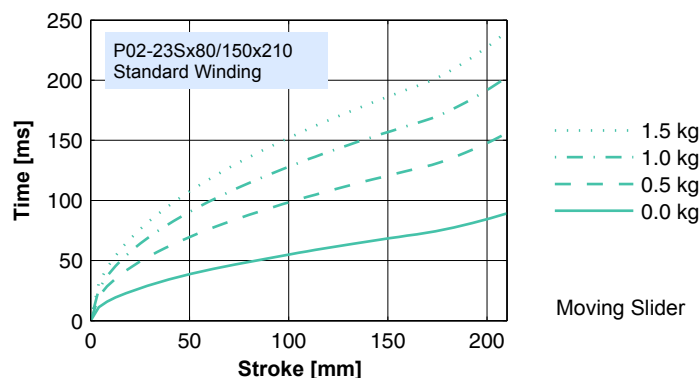

Moving Slider

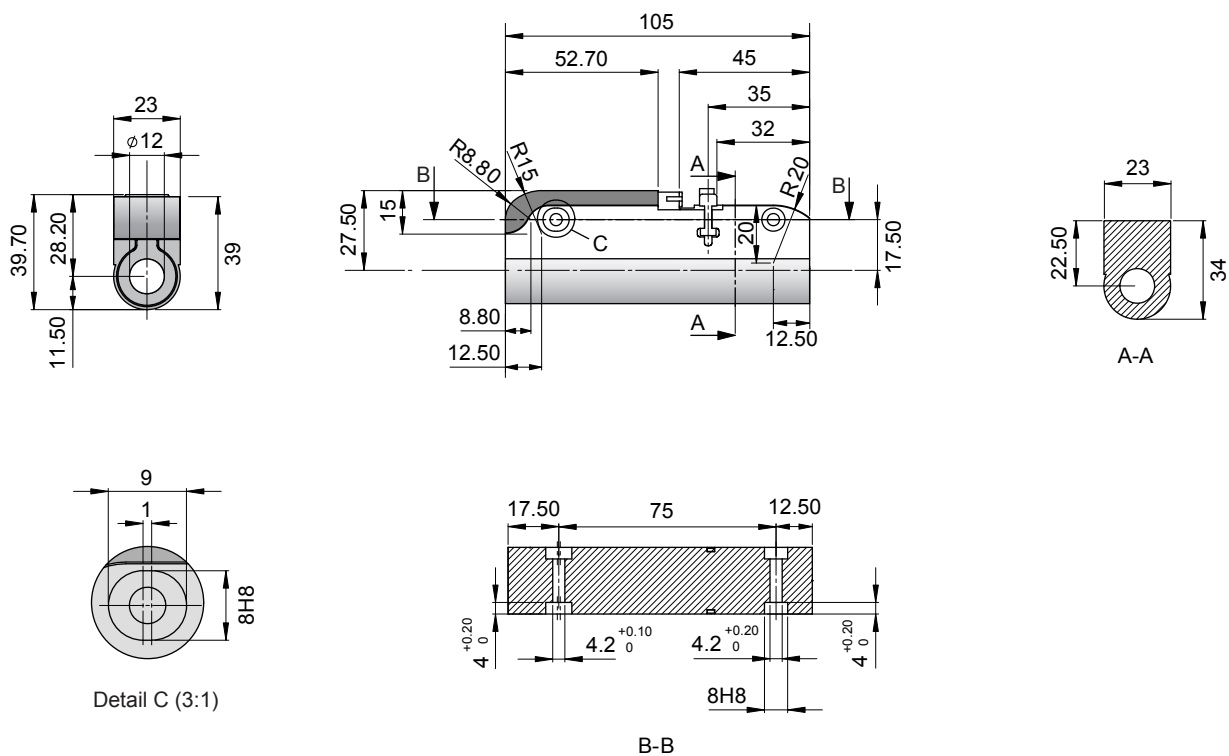

Linear Motor		Stator		Slider	
Type	Art.No	Type	Art. No.	Type	Art No.
P02-23Sx80/150x210	-->	PS02-23Sx80-F	0150-1272	& PL01-12x290/240	0150-1320

Slider

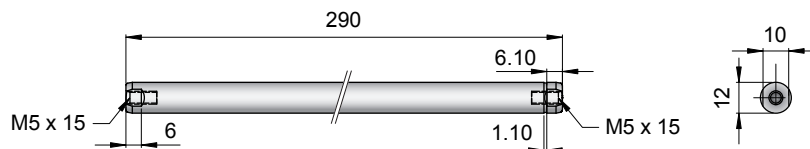

Standard Type	Slider Standard	PL01-12x290/240	0150-1320
Special Sliders	Heavy Duty Slider with WC/C-Coating	PL02-12x290/240	0150-1321
	Hollow Slider hole diameter 4.2mm	PL01-12x290/240-L	0150-1363

Connectors

Motor connector Wiring

Pin 1	Phase 2-
Pin 2	Phase 2-
Pin 3	Phase 1-
Pin 4	Phase 1-
Pin 5	+5V
Pin 6	Temp
Pin 7	GND
Pin 8	Cosine
Pin 9	Sine
Pin 10	Phase 2+
Pin 11	Phase 2+
Pin 12	Phase 1+
Pin 13	Phase 1+

Accessoires

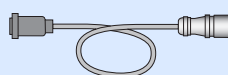

Standard Cable p. 508

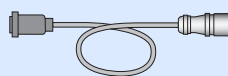

High Flex Cable p. 508

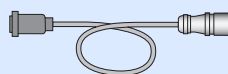

Robotic Cable p. 508



Servo Drive:
E100, E1001, E1100, B1100 p. 315

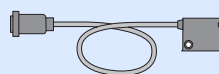

Optional Linear Encoder p. 526

Max. Stroke: 270mm
Peak Force: 44N

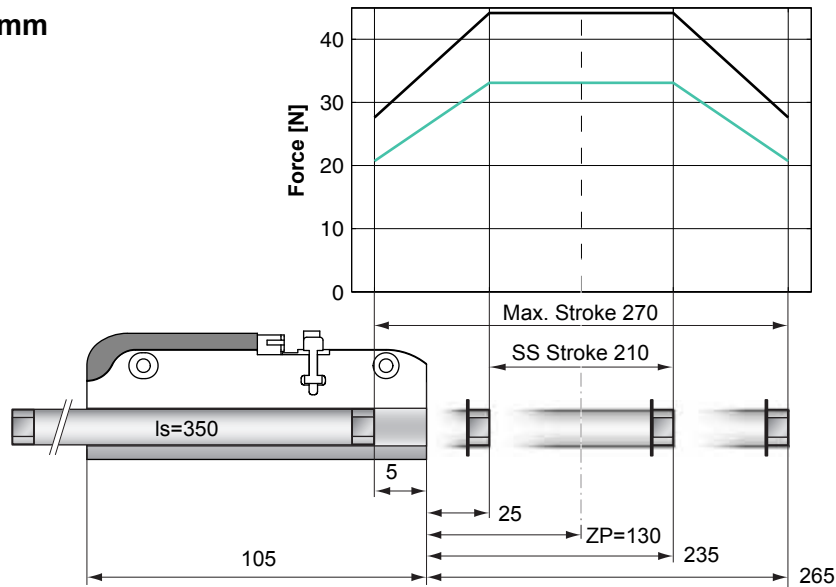

Standard Winding:
 — E1100, 72VDC & E1001, 72VDC
 — E100, 48VDC

Dimensions in mm

Motor Specification

		P02-23Sx80/210x270
Extended Stroke ES	mm (in)	270 (10.63)
Standard Stroke SS	mm (in)	210 (8.27)
Peak Force E1100 / E1001	N (lbf)	44 (9.9)
Peak Force E100	N (lbf)	33 (7.4)
Cont. Force	N (lbf)	9 (2.0)
Cont. Force Fan cooling	N (lbf)	16 (3.7)
Border Force	%	63
Force Constant	N/A (lbf/A)	11.0 (2.48)
Max. Current @ 72VDC	A	4.0
Max. Current @ 48VDC	A	3.8
Max. Velocity @ 72VDC	m/s (in/s)	6.0 (236)
Max. Velocity @ 48VDC	m/s (in/s)	4.0 (157)
Phase Resist. 25/80 °C	Ohm	10.3/12.5
Phase Inductance	mH	1.4
Thermal Resistance	°K/W	7.0
Thermal Time Const.	sec	900
Stator Diameter	mm (in)	23 (0.91)
Stator Length	mm (in)	105 (4.13)
Stator Mass	g (lb)	245 (0.54)
Slider Diameter	mm (in)	12 (0.47)
Slider Length	mm (in)	350 (13.78)
Slider Mass	g (lb)	271 (0.60)
Position Repeatability	mm (in)	±0.05 (±0.0020)
Linearity	%	±0.25
Repeatability with EPS	mm (in)	±0.01 (±0.0004)
Linearity with EPS	mm (in)	±0.01 (±0.0004)

Position-Time Diagram

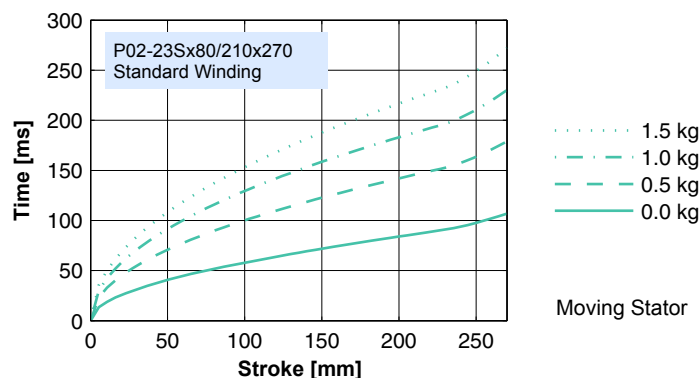

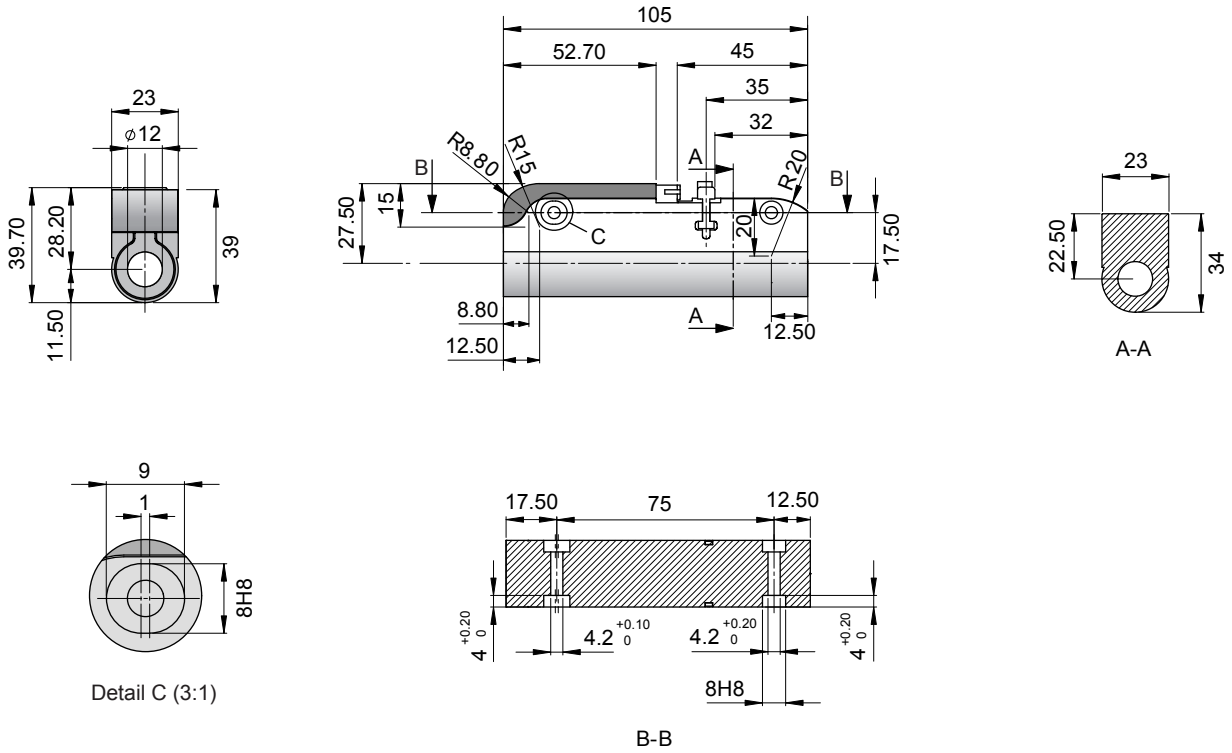

Linear Motor		Stator		Slider	
Type	Art.No	Type	Art. No.	Type	Art No.
P02-23Sx80/210x270	-->	PS02-23Sx80-F	0150-1272	& PL01-12x350/300	0150-1322

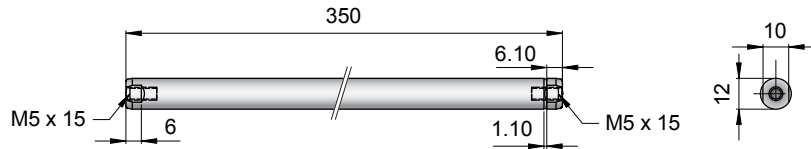

Standard Type	Slider Standard	PL01-12x350/300	0150-1322
Special Sliders	Heavy Duty Slider with WC/C-Coating	PL02-12x350/300	0150-1323
	Hollow Slider hole diameter 4.2mm	PL01-12x350/300-L	0150-1479

Motor connector Wiring

Pin 1	Phase 2-
Pin 2	Phase 2-
Pin 3	Phase 1-
Pin 4	Phase 1-
Pin 5	+5V
Pin 6	Temp
Pin 7	GND
Pin 8	Cosine
Pin 9	Sine
Pin 10	Phase 2+
Pin 11	Phase 2+
Pin 12	Phase 1+
Pin 13	Phase 1+

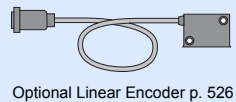
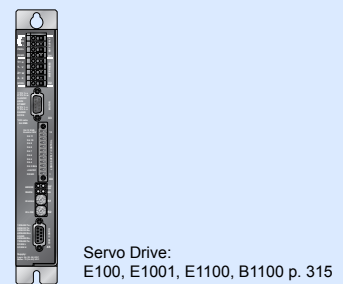
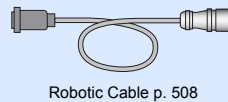
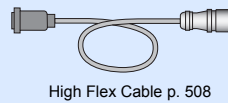
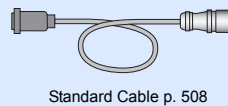

Max. Stroke: 340mm
Peak Force: 44N

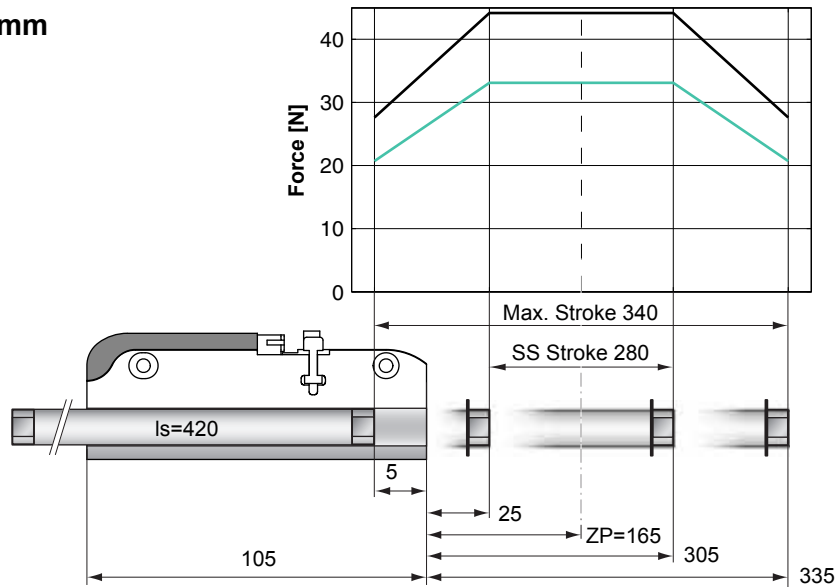

Standard Winding:
 — E1100, 72VDC & E1001, 72VDC
 — E100, 48VDC

Dimensions in mm

Motor Specification

		P02-23Sx80/280x340
Extended Stroke ES	mm (in)	340 (13.39)
Standard Stroke SS	mm (in)	280 (11.02)
Peak Force E1100 / E1001	N (lbf)	44 (9.9)
Peak Force E100	N (lbf)	33 (7.4)
Cont. Force	N (lbf)	9 (2.0)
Cont. Force Fan cooling	N (lbf)	16 (3.7)
Border Force	%	63
Force Constant	N/A (lbf/A)	11.0 (2.48)
Max. Current @ 72VDC	A	4.0
Max. Current @ 48VDC	A	3.8
Max. Velocity @ 72VDC	m/s (in/s)	6.0 (236)
Max. Velocity @ 48VDC	m/s (in/s)	4.0 (157)
Phase Resist. 25/80 °C	Ohm	10.3/12.5
Phase Inductance	mH	1.4
Thermal Resistance	°K/W	7.0
Thermal Time Const.	sec	900
Stator Diameter	mm (in)	23 (0.91)
Stator Length	mm (in)	105 (4.13)
Stator Mass	g (lb)	245 (0.54)
Slider Diameter	mm (in)	12 (0.47)
Slider Length	mm (in)	420 (16.54)
Slider Mass	g (lb)	330 (0.73)
Position Repeatability	mm (in)	±0.05 (±0.0020)
Linearity	%	±0.25
Repeatability with EPS	mm (in)	±0.01 (±0.0004)
Linearity with EPS	mm (in)	±0.01 (±0.0004)

Position-Time Diagram

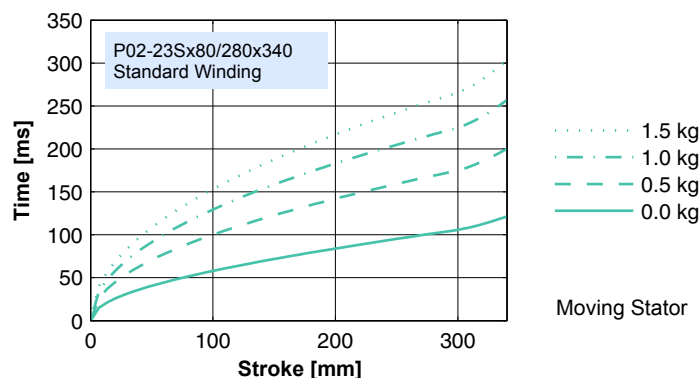

Moving Stator

Stator

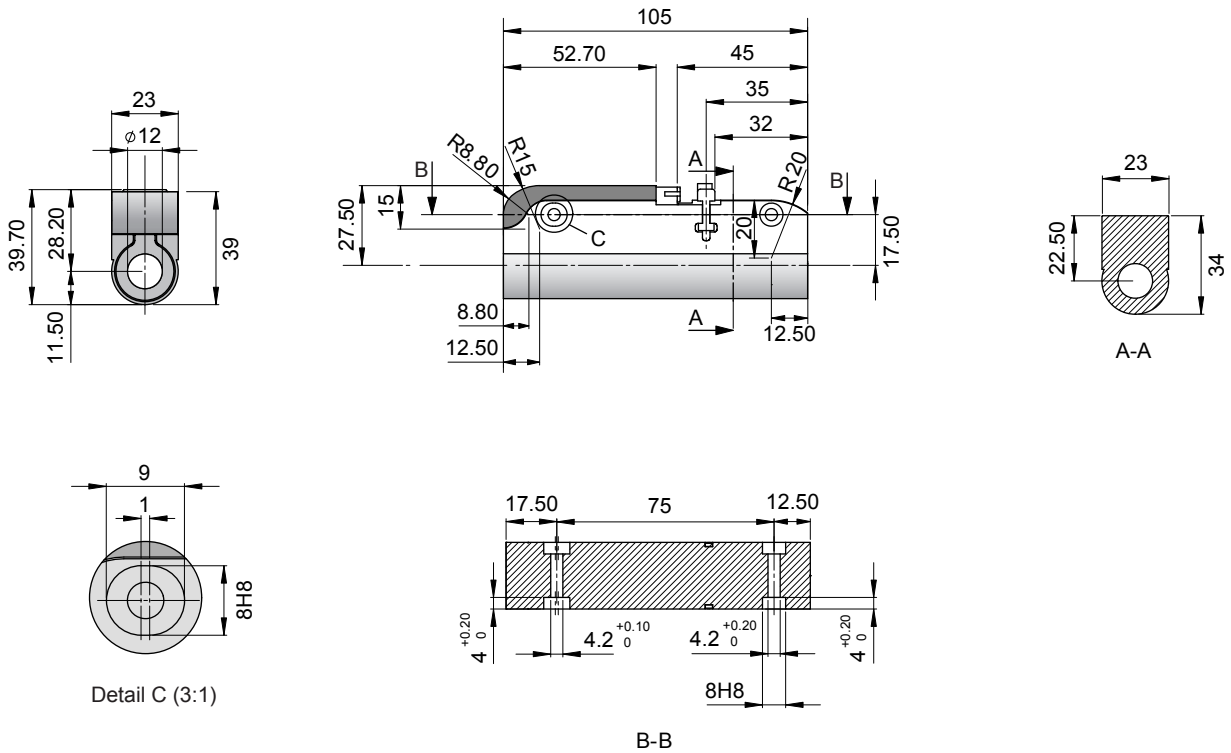

Linear Motor		Stator		Slider	
Type	Art.No	Type	Art. No.	Type	Art No.
P02-23Sx80/280x340	-->	PS02-23Sx80-F	0150-1272	& PL01-12x420/370	0150-1324

Slider

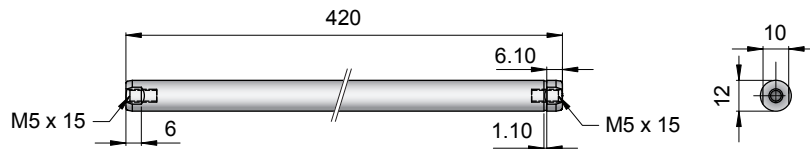

Standard Type	Slider Standard	PL01-12x420/370	0150-1324
Special Sliders	Heavy Duty Slider with WC/C-Coating	PL02-12x420/370	0150-1325
	Hollow Slider hole diameter 4.2mm	PL01-12x420/370-L	0150-1394

Connectors

Motor connector Wiring

Pin 1	Phase 2-
Pin 2	Phase 2-
Pin 3	Phase 1-
Pin 4	Phase 1-
Pin 5	+5V
Pin 6	Temp
Pin 7	GND
Pin 8	Cosine
Pin 9	Sine
Pin 10	Phase 2+
Pin 11	Phase 2+
Pin 12	Phase 1+
Pin 13	Phase 1+

Accessoires

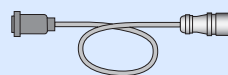

Standard Cable p. 508

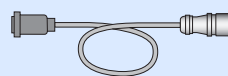

High Flex Cable p. 508

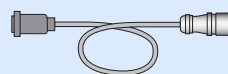

Robotic Cable p. 508



Servo Drive:
E100, E1001, E1100, B1100 p. 315

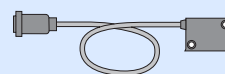

Optional Linear Encoder p. 526

Max. Stroke: 400mm
Peak Force: 44N

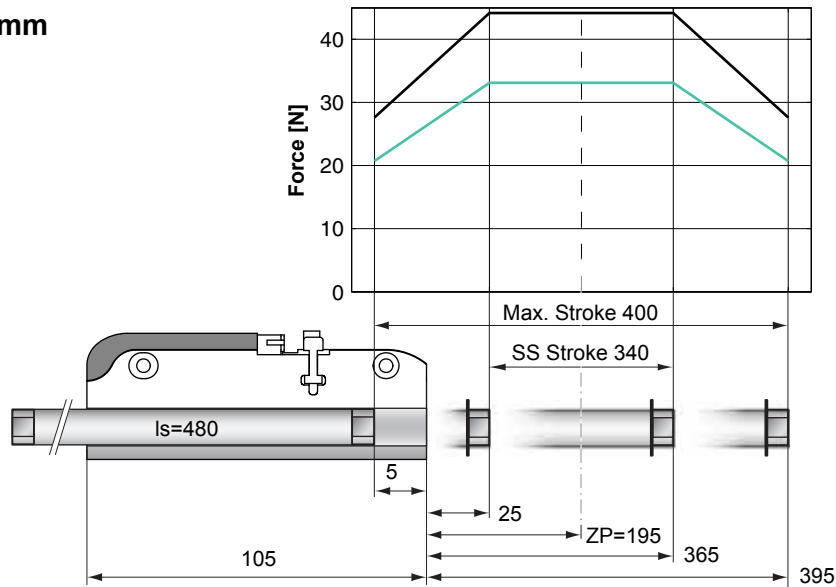

Standard Winding:
 — E1100, 72VDC & E1001, 72VDC
 — E100, 48VDC

Dimensions in mm

Motor Specification

		P02-23Sx80/340x400
Extended Stroke ES	mm (in)	400 (15.75)
Standard Stroke SS	mm (in)	340 (13.39)
Peak Force E1100 / E1001	N (lbf)	44 (9.9)
Peak Force E100	N (lbf)	33 (7.4)
Cont. Force	N (lbf)	9 (2.0)
Cont. Force Fan cooling	N (lbf)	16 (3.7)
Border Force	%	63
Force Constant	N/A (lbf/A)	11.0 (2.48)
Max. Current @ 72VDC	A	4.0
Max. Current @ 48VDC	A	3.8
Max. Velocity @ 72VDC	m/s (in/s)	6.0 (236)
Max. Velocity @ 48VDC	m/s (in/s)	4.0 (157)
Phase Resist. 25/80 °C	Ohm	10.3/12.5
Phase Inductance	mH	1.4
Thermal Resistance	°K/W	7.0
Thermal Time Const.	sec	900
Stator Diameter	mm (in)	23 (0.91)
Stator Length	mm (in)	105 (4.13)
Stator Mass	g (lb)	245 (0.54)
Slider Diameter	mm (in)	12 (0.47)
Slider Length	mm (in)	480 (18.90)
Slider Mass	g (lb)	380 (0.84)
Position Repeatability	mm (in)	±0.05 (±0.0020)
Linearity	%	±0.25
Repeatability with EPS	mm (in)	±0.01 (±0.0004)
Linearity with EPS	mm (in)	±0.01 (±0.0004)

Position-Time Diagram

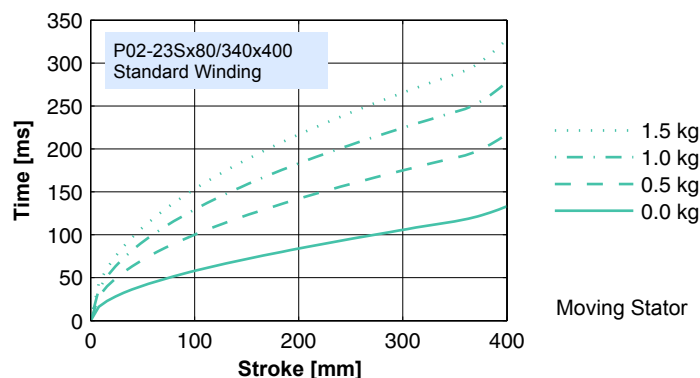

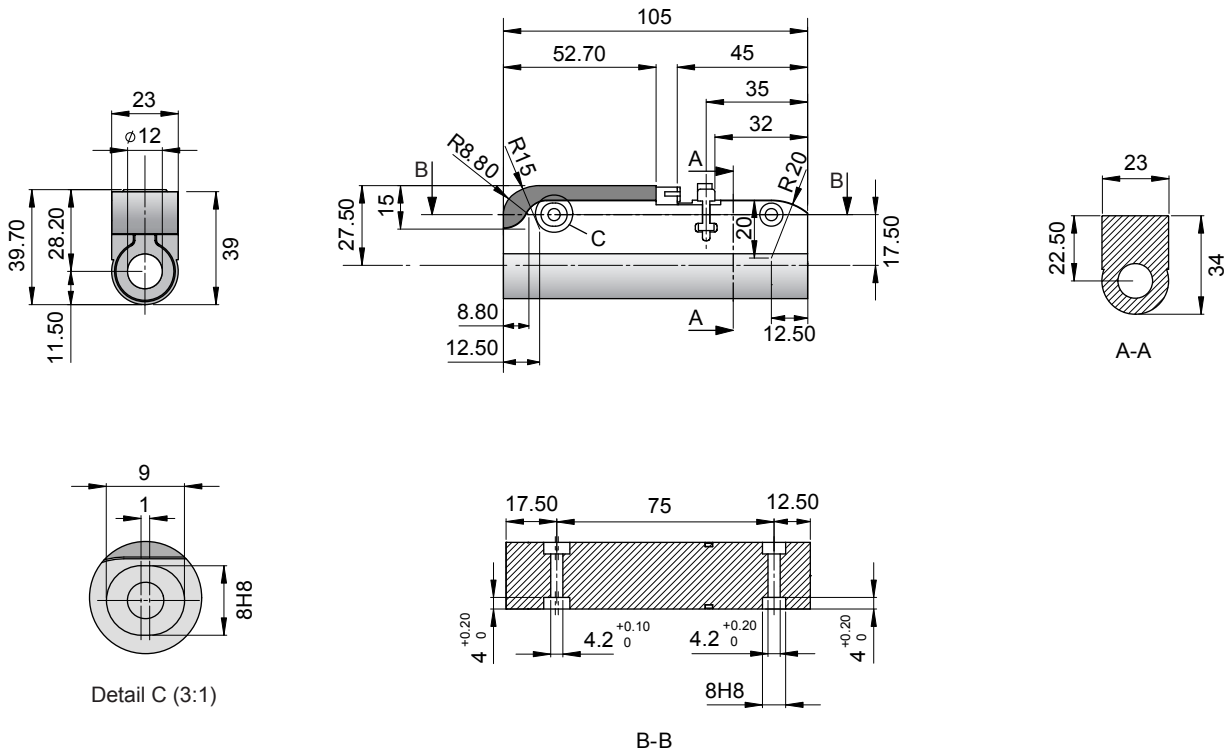

Linear Motor		Stator		Slider	
Type	Art.No	Type	Art. No.	Type	Art No.
P02-23Sx80/340x400	-->	PS02-23Sx80-F	0150-1272	& PL01-12x480/430	0150-1372

Slider

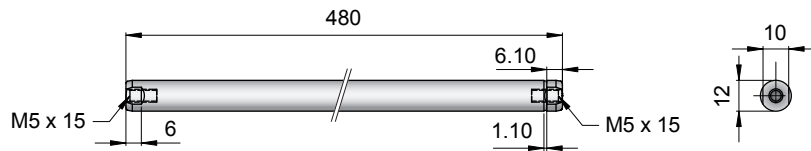

Standard Type	Slider Standard	PL01-12x480/430	0150-1372
Special Sliders	Heavy Duty Slider with WC/C-Coating	PL02-12x480/430	0150-1373
	Hollow Slider hole diameter 4.2mm	PL01-12x480/430-L	on request

Connectors

Motor connector Wiring

Pin 1	Phase 2-
Pin 2	Phase 2-
Pin 3	Phase 1-
Pin 4	Phase 1-
Pin 5	+5V
Pin 6	Temp
Pin 7	GND
Pin 8	Cosine
Pin 9	Sine
Pin 10	Phase 2+
Pin 11	Phase 2+
Pin 12	Phase 1+
Pin 13	Phase 1+

Accessoires

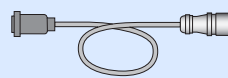

Standard Cable p. 508

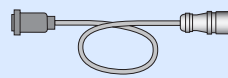

High Flex Cable p. 508

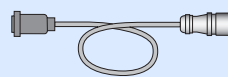

Robotic Cable p. 508



Servo Drive:
E100, E1001, E1100, B1100 p. 315

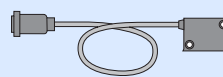

Optional Linear Encoder p. 526

Max. Stroke: 500mm
Peak Force: 44N

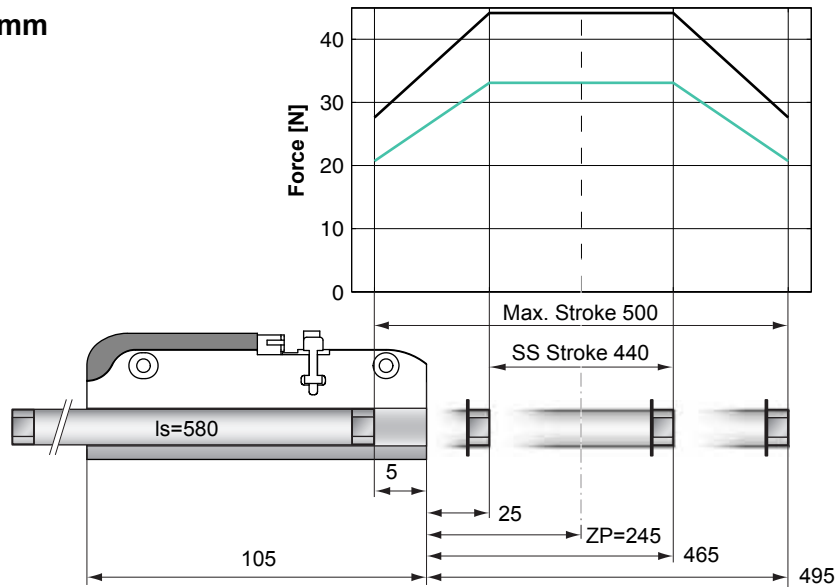

Standard Winding:
 — E1100, 72VDC & E1001, 72VDC
 — E100, 48VDC

Dimensions in mm

Motor Specification

		P02-23Sx80/440x500
Extended Stroke ES	mm (in)	500 (19.69)
Standard Stroke SS	mm (in)	440 (17.32)
Peak Force E1100 / E1001	N (lbf)	44 (9.9)
Peak Force E100	N (lbf)	33 (7.4)
Cont. Force	N (lbf)	9 (2.0)
Cont. Force Fan cooling	N (lbf)	16 (3.7)
Border Force	%	63
Force Constant	N/A (lbf/A)	11.0 (2.48)
Max. Current @ 72VDC	A	4.0
Max. Current @ 48VDC	A	3.8
Max. Velocity @ 72VDC	m/s (in/s)	6.0 (236)
Max. Velocity @ 48VDC	m/s (in/s)	4.0 (157)
Phase Resist. 25/80 °C	Ohm	10.3/12.5
Phase Inductance	mH	1.4
Thermal Resistance	°K/W	7.0
Thermal Time Const.	sec	900
Stator Diameter	mm (in)	23 (0.91)
Stator Length	mm (in)	105 (4.13)
Stator Mass	g (lb)	245 (0.54)
Slider Diameter	mm (in)	12 (0.47)
Slider Length	mm (in)	580 (22.83)
Slider Mass	g (lb)	465 (1.03)
Position Repeatability	mm (in)	±0.05 (±0.0020)
Linearity	%	±0.20
Repeatability with EPS	mm (in)	±0.01 (±0.0004)
Linearity with EPS	mm (in)	±0.01 (±0.0004)

Position-Time Diagram

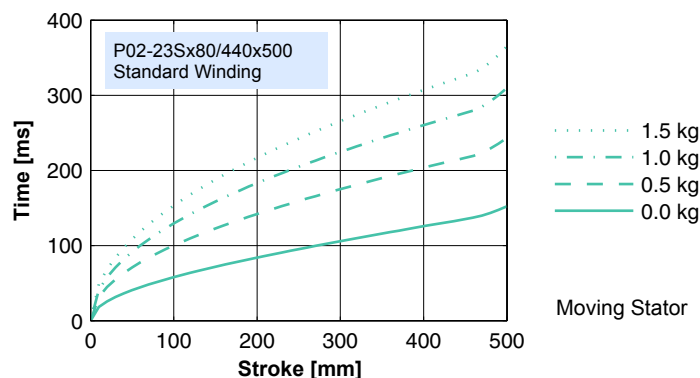

Stator

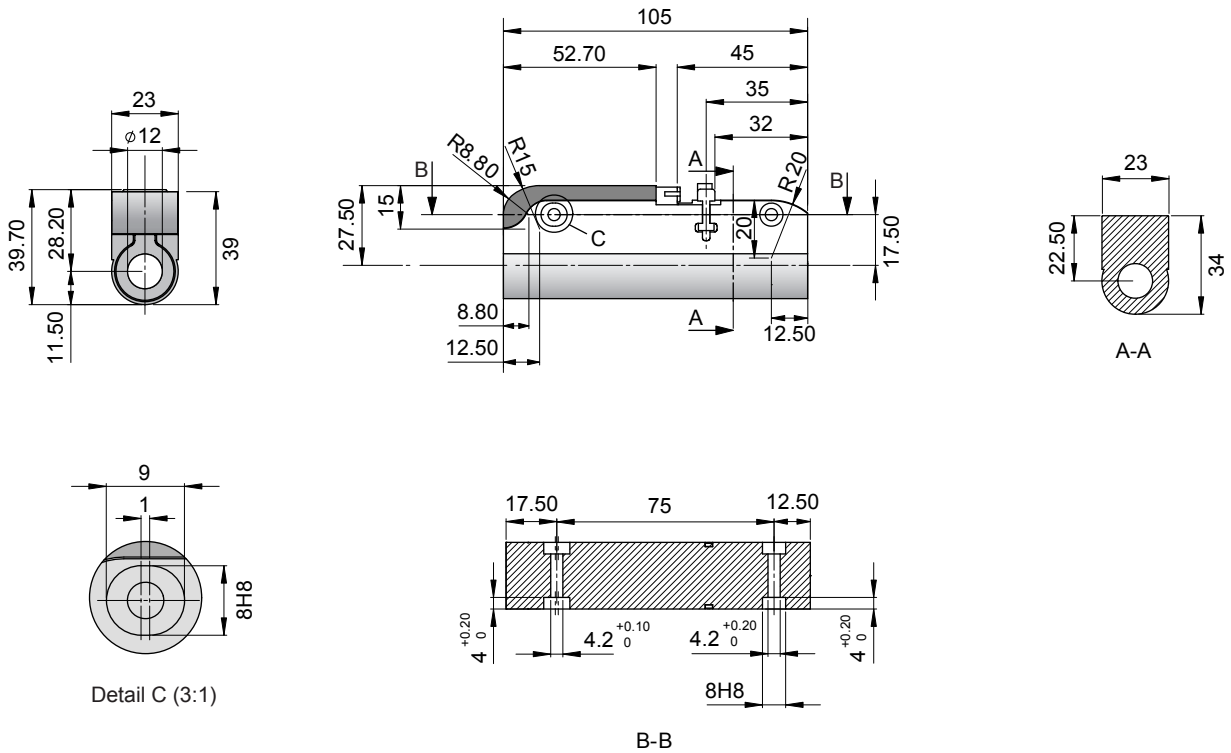

Linear Motor		Stator		Slider	
Type	Art.No	Type	Art. No.	Type	Art No.
P02-23Sx80/440x500	-->	PS02-23Sx80-F	0150-1272	& PL01-12x580/530	0150-1355

Slider

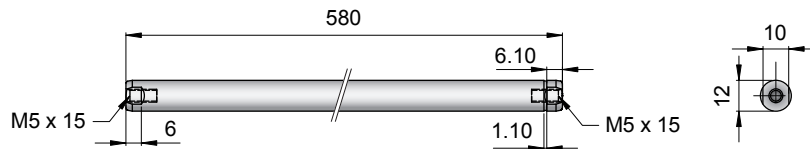

Standard Type	Slider Standard	PL01-12x580/530	0150-1355
Special Sliders	Heavy Duty Slider with WC/C-Coating	PL02-12x580/530	0150-1356
	Hollow Slider hole diameter 4.2mm	PL01-12x580/530-L	0150-1391

Connectors

Motor connector Wiring

Pin 1	Phase 2-
Pin 2	Phase 2-
Pin 3	Phase 1-
Pin 4	Phase 1-
Pin 5	+5V
Pin 6	Temp
Pin 7	GND
Pin 8	Cosine
Pin 9	Sine
Pin 10	Phase 2+
Pin 11	Phase 2+
Pin 12	Phase 1+
Pin 13	Phase 1+

Accessoires

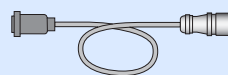

Standard Cable p. 508

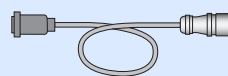

High Flex Cable p. 508

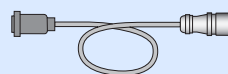

Robotic Cable p. 508



Servo Drive:
E100, E1001, E1100, B1100 p. 315

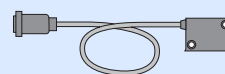

Optional Linear Encoder p. 526

Max. Stroke: 680mm
Peak Force: 44N

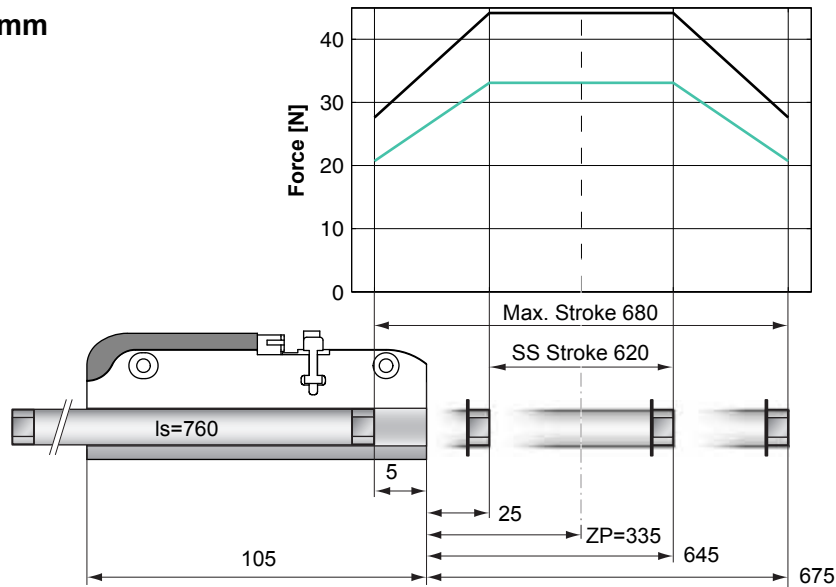

Standard Winding:
 — E1100, 72VDC & E1001, 72VDC
 — E100, 48VDC

Dimensions in mm

Motor Specification

		P02-23Sx80/620x680
Extended Stroke ES	mm (in)	680 (26.77)
Standard Stroke SS	mm (in)	620 (24.41)
Peak Force E1100 / E1001	N (lbf)	44 (9.9)
Peak Force E100	N (lbf)	33 (7.4)
Cont. Force	N (lbf)	9 (2.0)
Cont. Force Fan cooling	N (lbf)	16 (3.7)
Border Force	%	63
Force Constant	N/A (lbf/A)	11.0 (2.48)
Max. Current @ 72VDC	A	4.0
Max. Current @ 48VDC	A	3.8
Max. Velocity @ 72VDC	m/s (in/s)	6.0 (236)
Max. Velocity @ 48VDC	m/s (in/s)	4.0 (157)
Phase Resist. 25/80 °C	Ohm	10.3/12.5
Phase Inductance	mH	1.4
Thermal Resistance	°K/W	7.0
Thermal Time Const.	sec	900
Stator Diameter	mm (in)	23 (0.91)
Stator Length	mm (in)	105 (4.13)
Stator Mass	g (lb)	245 (0.54)
Slider Diameter	mm (in)	12 (0.47)
Slider Length	mm (in)	760 (29.92)
Slider Mass	g (lb)	615 (1.36)
Position Repeatability	mm (in)	±0.05 (±0.0020)
Linearity	%	±0.20
Repeatability with EPS	mm (in)	±0.01 (±0.0004)
Linearity with EPS	mm (in)	±0.01 (±0.0004)

Position-Time Diagram

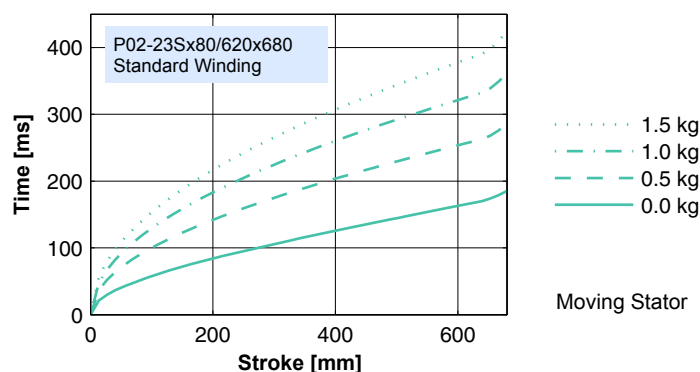

Moving Stator

Stator

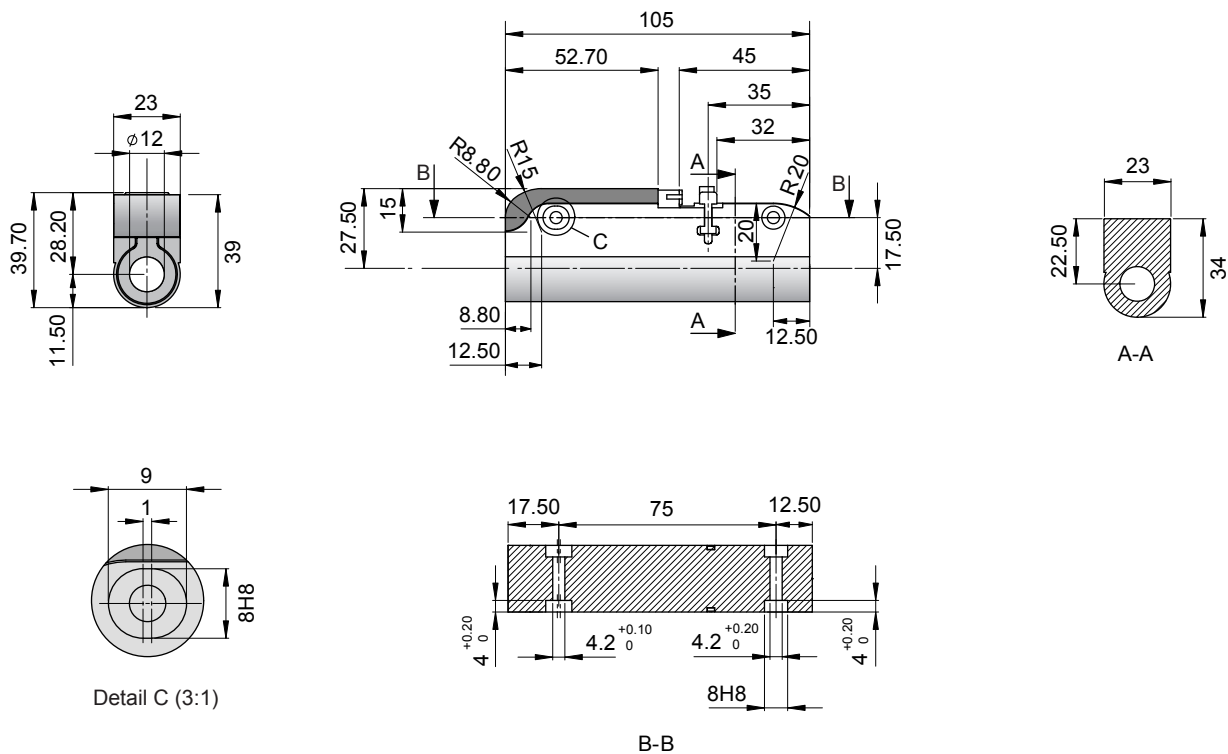

Linear Motor		Stator		Slider	
Type	Art.No	Type	Art. No.	Type	Art No.
P02-23Sx80/620x680	-->	PS02-23Sx80-F	0150-1272	& PL01-12x760/710	0150-1366

Slider

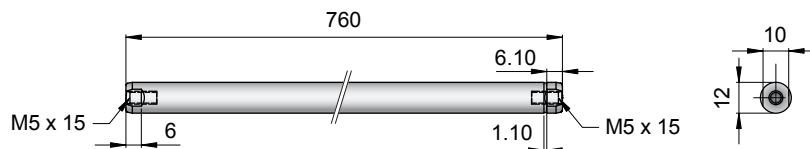

Standard Type	Slider Standard	PL01-12x760/710	0150-1366
Special Sliders	Heavy Duty Slider with WC/C-Coating	PL02-12x760/710	on request
	Hollow Slider hole diameter 4.2mm	PL01-12x760/710-L	0150-1392

Connectors

Motor connector Wiring

Pin 1	Phase 2-
Pin 2	Phase 2-
Pin 3	Phase 1-
Pin 4	Phase 1-
Pin 5	+5V
Pin 6	Temp
Pin 7	GND
Pin 8	Cosine
Pin 9	Sine
Pin 10	Phase 2+
Pin 11	Phase 2+
Pin 12	Phase 1+
Pin 13	Phase 1+

Accessoires

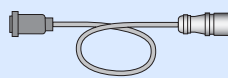

Standard Cable p. 508

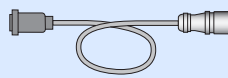

High Flex Cable p. 508

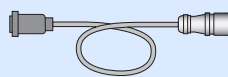

Robotic Cable p. 508



Servo Drive:
E100, E1001, E1100, B1100 p. 315

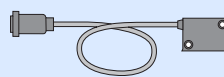

Optional Linear Encoder p. 526

Max. Stroke: 770mm
Peak Force: 44N

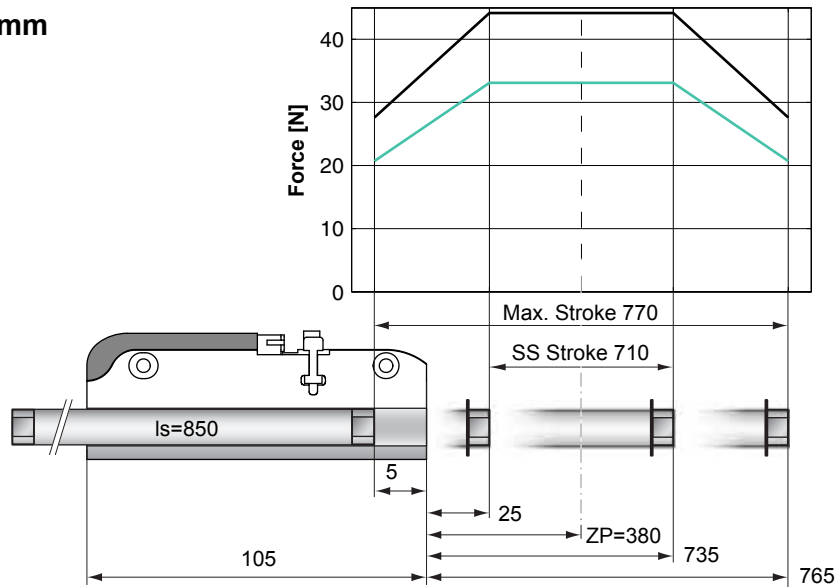

Standard Winding:
 — E1100, 72VDC &
 E1001, 72VDC
 — E100, 48VDC

Dimensions in mm

Motor Specification

		P02-23Sx80/710x770
Extended Stroke ES	mm (in)	770 (30.31)
Standard Stroke SS	mm (in)	710 (27.95)
Peak Force E1100 / E1001	N (lbf)	44 (9.9)
Peak Force E100	N (lbf)	33 (7.4)
Cont. Force	N (lbf)	9 (2.0)
Cont. Force Fan cooling	N (lbf)	16 (3.7)
Border Force	%	63
Force Constant	N/A (lbf/A)	11.0 (2.48)
Max. Current @ 72VDC	A	4.0
Max. Current @ 48VDC	A	3.8
Max. Velocity @ 72VDC	m/s (in/s)	6.0 (236)
Max. Velocity @ 48VDC	m/s (in/s)	4.0 (157)
Phase Resist. 25/80 °C	Ohm	10.3/12.5
Phase Inductance	mH	1.4
Thermal Resistance	°K/W	7.0
Thermal Time Const.	sec	900
Stator Diameter	mm (in)	23 (0.91)
Stator Length	mm (in)	105 (4.13)
Stator Mass	g (lb)	245 (0.54)
Slider Diameter	mm (in)	12 (0.47)
Slider Length	mm (in)	850 (33.46)
Slider Mass	g (lb)	690 (1.52)
Position Repeatability	mm (in)	±0.05 (±0.0020)
Linearity	%	±0.20
Repeatability with EPS	mm (in)	±0.01 (±0.0004)
Linearity with EPS	mm (in)	±0.01 (±0.0004)

Position-Time Diagram

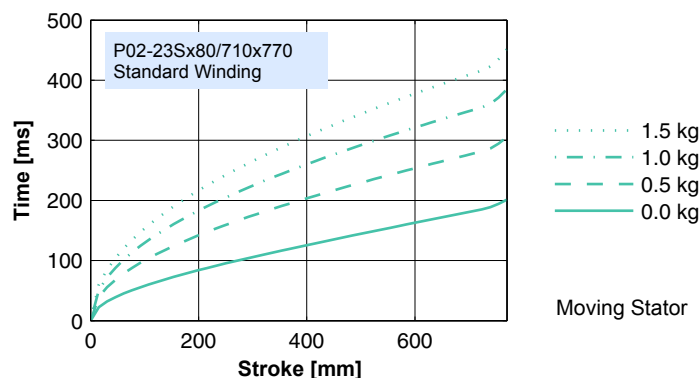

Moving Stator

Stator

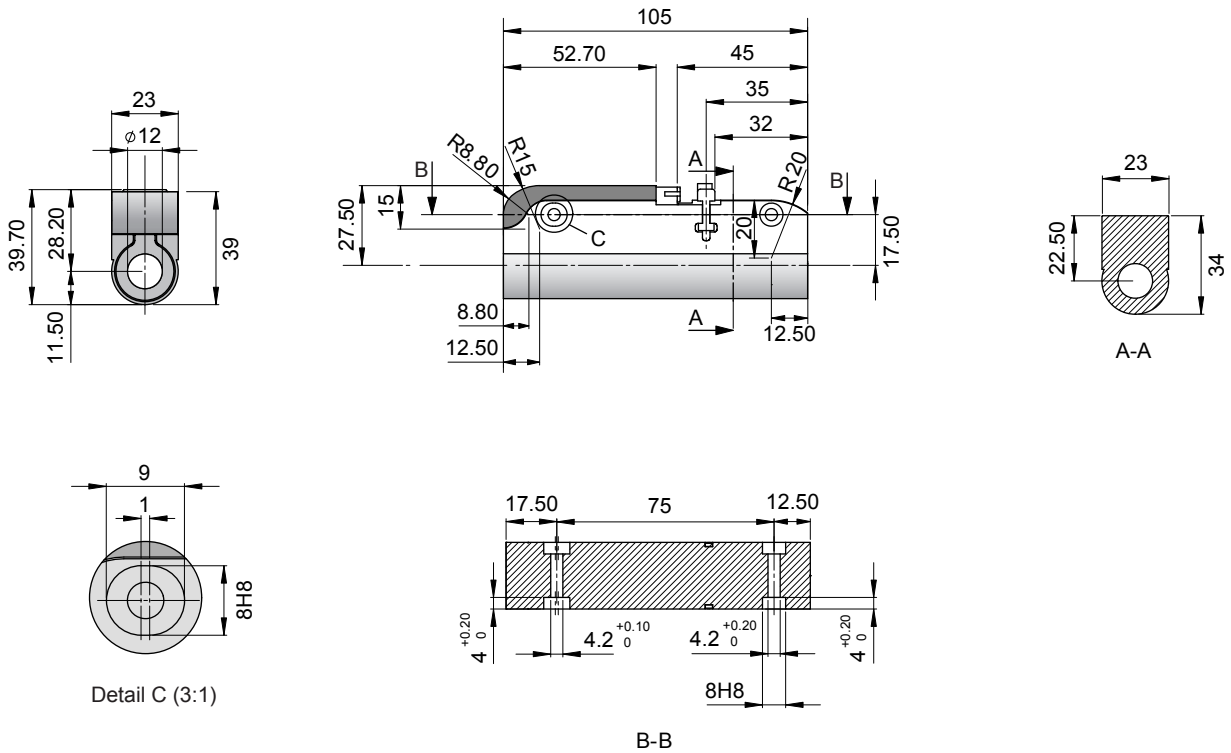

Linear Motor		Stator		Slider	
Type	Art.No	Type	Art. No.	Type	Art No.
P02-23Sx80/710x770	-->	PS02-23Sx80-F	0150-1272	& PL01-12x850/800	0150-1365

Slider

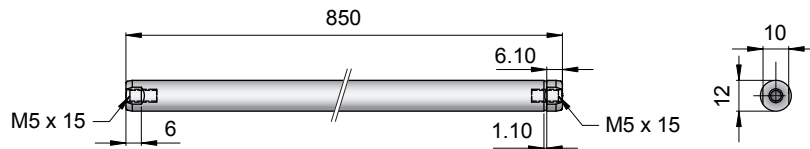

Standard Type	Slider Standard	PL01-12x850/800	0150-1365
Special Sliders	Heavy Duty Slider with WC/C-Coating	PL02-12x850/800	on request
	Hollow Slider hole diameter 4.2mm	PL01-12x850/800-L	on request

Connectors

Motor connector Wiring

Pin 1	Phase 2-
Pin 2	Phase 2-
Pin 3	Phase 1-
Pin 4	Phase 1-
Pin 5	+5V
Pin 6	Temp
Pin 7	GND
Pin 8	Cosine
Pin 9	Sine
Pin 10	Phase 2+
Pin 11	Phase 2+
Pin 12	Phase 1+
Pin 13	Phase 1+

Accessoires

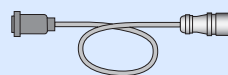

Standard Cable p. 508

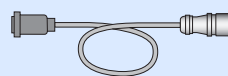

High Flex Cable p. 508

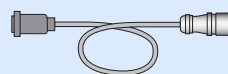

Robotic Cable p. 508



Servo Drive:
E100, E1001, E1100, B1100 p. 315

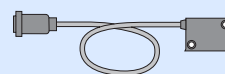

Optional Linear Encoder p. 526



Series P02-23Sx80F-HP 224

P02-23Sx80F/0x60-HP 227

P02-23Sx80F/20x80-HP 228

P02-23Sx80F/40x100-HP 229

P02-23Sx80F/70x130-HP 230

P02-23Sx80F/100x160-HP 231

P02-23Sx80F/140x200-HP 232

P02-23Sx80F/160x220-HP 233

P02-23Sx80F/220x280-HP 234

P02-23Sx80F/290x350-HP 235

P02-23Sx80F/350x410-HP 236

P02-23Sx80F/450x510-HP 237

P02-23Sx80F/630x690-HP 238

P02-23Sx80F/720x780-HP 239

Motor Cable 240



Motor Specification

		P02-23Sx80F-HP/...
Maximum Stroke	mm (in)	780 (30.71)
Maximum Force	N (lbf)	67 (15.1)
Maximum Velocity	m/s (in/s)	7.3 (287)
Max. Current	A	7.5
Cont. Current	A	1.5
Phase Resist. 25 °C	Ohm	10.3
Phase Resist. 80 °C	Ohm	12.5
Phase Inductance	mH	1.4
Thermal Resistance	°K/W	7.0
Thermal Time Const.	sec	900
Stator Diameter	mm (in)	23 (0.91)
Stator Length	mm (in)	105 (4.13)
Stator Mass	g (lb)	245 (0.54)
Slider Diameter	mm (in)	12 (0.47)
Position Resolution	mm (in)	0.01 (±0.0004)
Position Repeatability	mm (in)	±0.05 (±0.0020)
Position Resolution ES	mm (in)	0.001 (±0.00004)
Repeatability with EPS	mm (in)	±0.01 (±0.0004)

Accessories

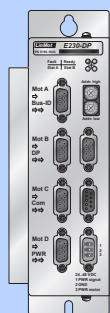

Servo Drive:
E100



E1100



E1200



B1100

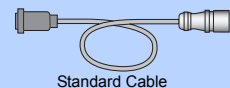

Standard Cable

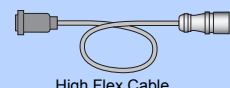

High Flex Cable

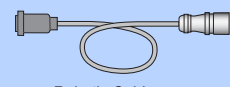

Robotic Cable

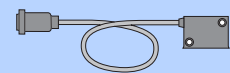

Optional Linear Encoder

Stator

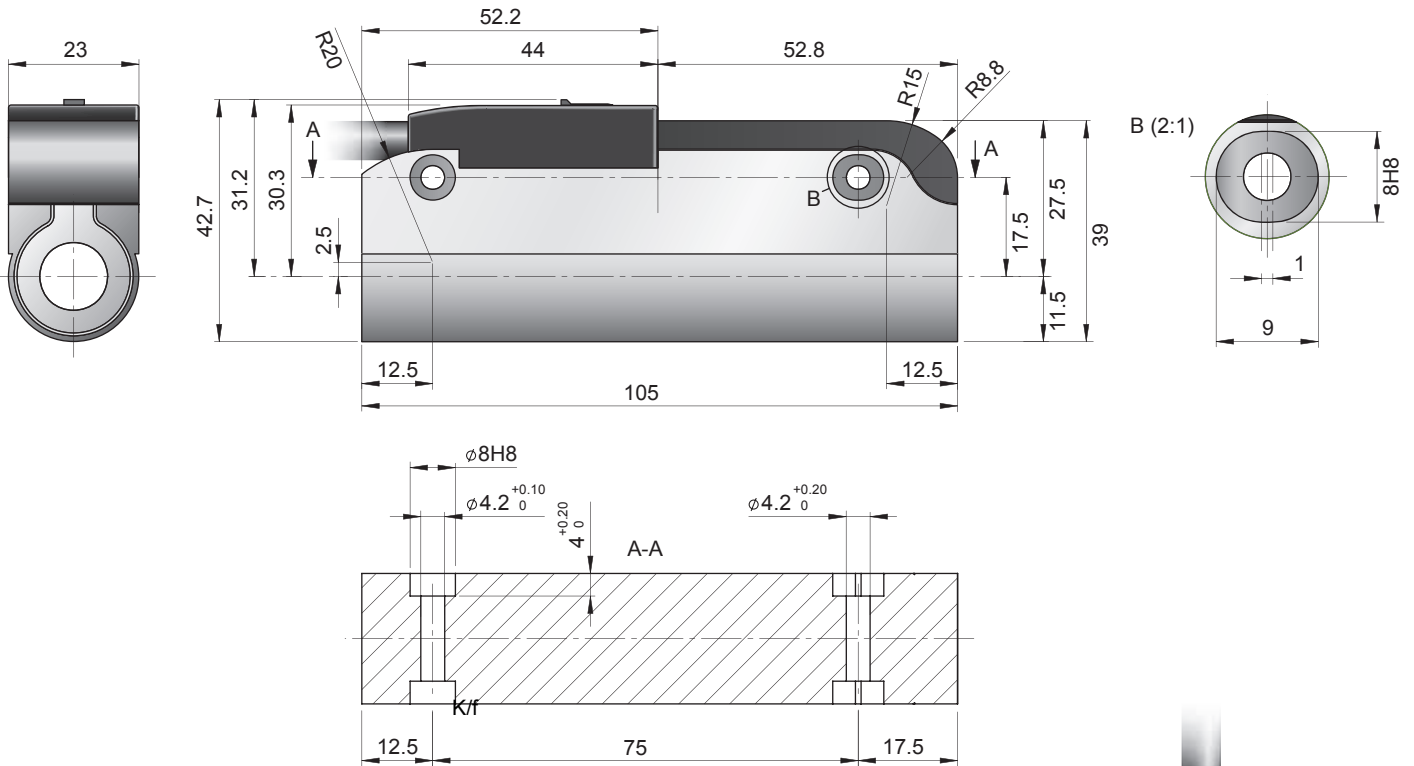

K-Connector

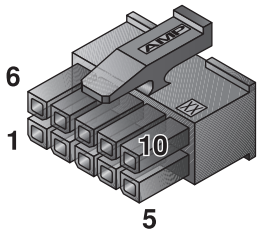
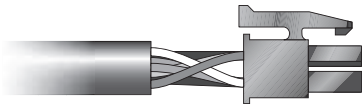

Motor Connector Wiring

Pin 1	red	Phase 1+
Pin 2	blue	Phase 2+
Pin 3		n.c.
Pin 4	pink	Phase 1-
Pin 5	grey	Phase 2-
Pin 6	yellow	Sensor Sin
Pin 7	green	Sensor Cos
Pin 8	brown	Ground
Pin 9	white	+5V
Pin 10	black	Temp sensor
shield	case	Shield

Stators are shipped with three covers for left/right/straight cable outlet

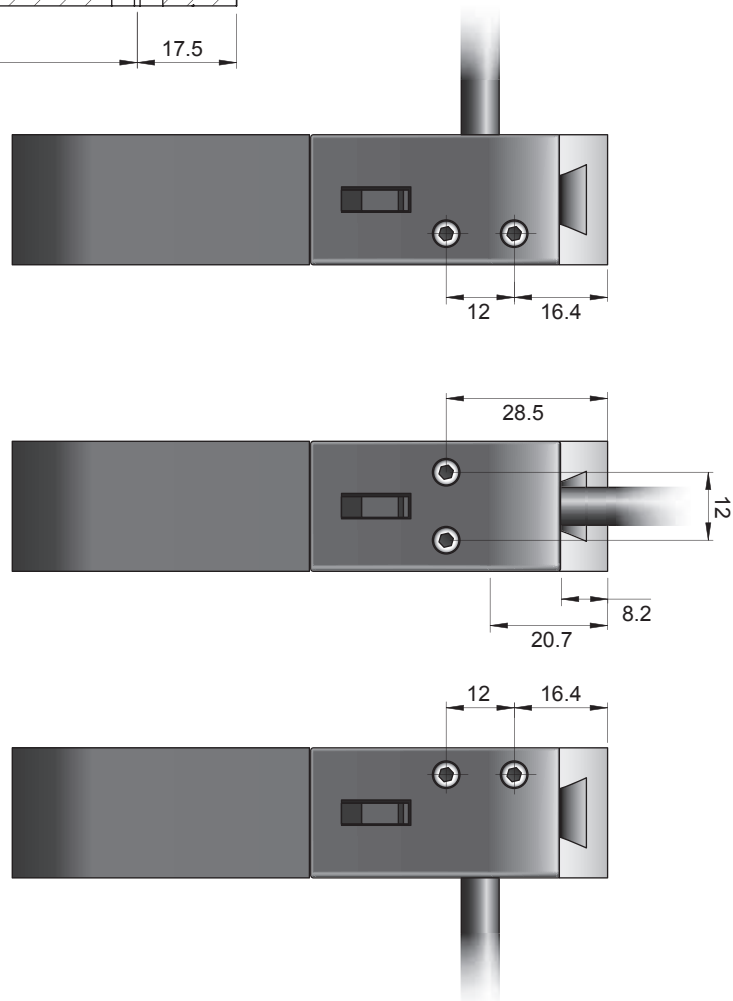

Ordering Information

Item	Description	Part Number
PS02-23Sx80F-HP-K	Stator HP with K-connector IP50	0150-1285

Sliders

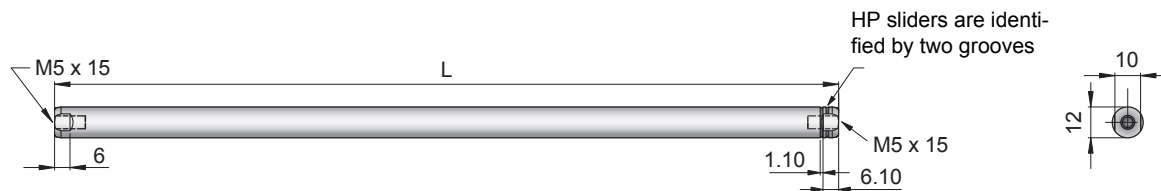

High Performance Slider		Length[mm]	Stroke[mm]	Part Number
PL01-12x130/90-HP	slider "High Performance"	130	0x60	0150-2209
PL01-12x150/110-HP	slider "High Performance"	150	20x80	0150-2281
PL01-12x170/130-HP	slider "High Performance"	170	40x100	0150-1529
PL01-12x200/160-HP	slider "High Performance"	200	70x130	0150-1518
PL01-12x230/190-HP	slider "High Performance"	230	100x160	0150-1519
PL01-12x270/230-HP	slider "High Performance"	270	140x200	0150-1520
PL01-12x290/250-HP	slider "High Performance"	290	160x220	0150-1521
PL01-12x350/310-HP	slider "High Performance"	350	220x280	0150-1522
PL01-12x420/380-HP	slider "High Performance"	420	290x350	0150-1523
PL01-12x480/440-HP	slider "High Performance"	480	350x410	0150-1524
PL01-12x580/540-HP	slider "High Performance"	580	450x510	0150-1525
PL01-12x760/720-HP	slider "High Performance"	760	630x690	0150-1526
PL01-12x850/810-HP	slider "High Performance"	850	720x780	0150-1527

Heavy Duty High Performance Slider		Length[mm]	Stroke[mm]	Part Number
PL02-12x130/90-HP	slider "heavy duty" "High Performance"	130	0x60	on request
PL02-12x150/110-HP	slider "heavy duty" "High Performance"	150	20x80	on request
PL02-12x170/130-HP	slider "heavy duty" "High Performance"	170	40x100	0150-1559
PL02-12x200/160-HP	slider "heavy duty" "High Performance"	200	70x130	0150-1532
PL02-12x230/190-HP	slider "heavy duty" "High Performance"	230	100x160	0150-1552
PL02-12x270/230-HP	slider "heavy duty" "High Performance"	270	140x200	0150-1533
PL02-12x290/250-HP	slider "heavy duty" "High Performance"	290	160x220	0150-1495
PL02-12x350/310-HP	slider "heavy duty" "High Performance"	350	220x280	0150-1555
PL02-12x420/380-HP	slider "heavy duty" "High Performance"	420	290x350	0150-1554
PL02-12x480/440-HP	slider "heavy duty" "High Performance"	480	350x410	on request
PL02-12x580/540-HP	slider "heavy duty" "High Performance"	580	450x510	on request
PL02-12x760/720-HP	slider "heavy duty" "High Performance"	760	630x690	on request
PL02-12x850/810-HP	slider "heavy duty" "High Performance"	850	720x780	on request

Max. Stroke: 60mm
Max. Force: 67N

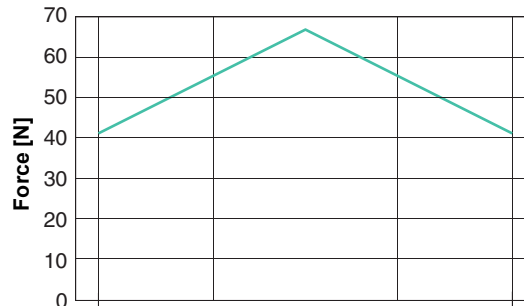

— E1100, 72VDC

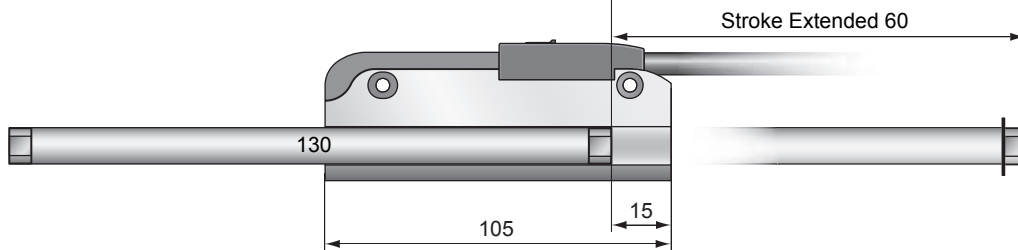

Dimensions in mm

Motor Specification

Stator Type		Standard Winding
Slider Type		High Performance High Performance Heavy Duty
Standard Stroke SS	mm (in)	- (-)
Extended Stroke ES	mm (in)	60 (2.36)
Max. Force	N (lbf)	67 (15.1)
Cont. Force	N (lbf)	15 (3.5)
Cont. Force with fan	N (lbf)	25 (5.6)
Max. Velocity	m/s (in/s)	7.3 (287)
Max. Current	A	7.5
Cont. Current	A	1.5
Cont. Current with fan	A	2.2
Force Constant	N/A (lbf/A)	9 (2.0)
Border Force	%	63
Linearity	%	±0.1
Slider Length	mm (in)	130 (5.12)
Slider Mass	g (lb)	90 (0.20)

Ordering Information

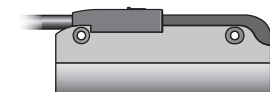

PS02-23Sx80F-HP-K	Stator HP with K-connector IP50	0150-1285
-------------------	---------------------------------	-----------



PL01-12x130/90-HP	High Performance Slider	0150-2209
PL02-12x130/90-HP	High Performance Slider, Heavy Duty	on request

Max. Stroke: 80mm
Max. Force: 67N

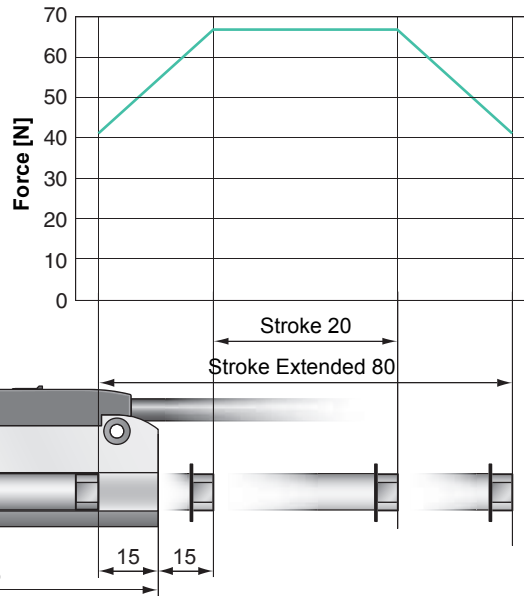

Dimensions in mm

Motor Specification

Stator Type		Standard Winding
Slider Type		High Performance High Performance Heavy Duty
Standard Stroke SS	mm (in)	20 (0.79)
Extended Stroke ES	mm (in)	80 (3.15)
Max. Force	N (lbf)	67 (15.1)
Cont. Force	N (lbf)	15 (3.5)
Cont. Force with fan	N (lbf)	25 (5.6)
Max. Velocity	m/s (in/s)	7.3 (287)
Max. Current	A	7.5
Cont. Current	A	1.5
Cont. Current with fan	A	2.2
Force Constant	N/A (lbf/A)	9 (2.0)
Border Force	%	63
Linearity	%	±0.1
Slider Length	mm (in)	150 (5.91)
Slider Mass	g (lb)	110 (4.33)

Ordering Information

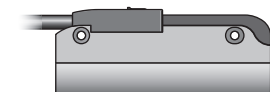

PS02-23Sx80F-HP-K	Stator HP with K-connector IP50	0150-1285
-------------------	---------------------------------	-----------



PL01-12x150/110-HP	High Performance Slider	0150-2281
PL02-12x150/110-HP	High Performance Slider, Heavy Duty	on request

Max. Stroke: 100mm
Max. Force: 67N

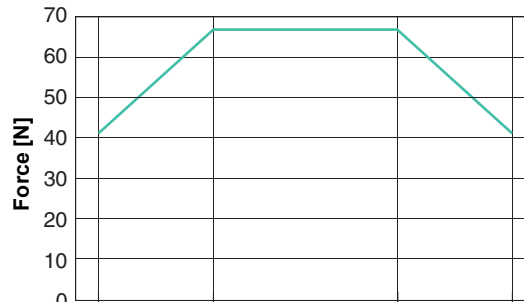

E1100, 72VDC

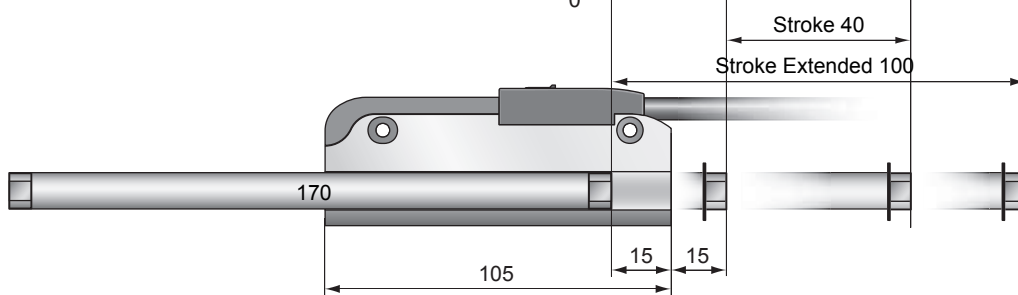

Dimensions in mm

Motor Specification

Stator Type		Standard Winding
Slider Type		High Performance High Performance Heavy Duty
Standard Stroke SS	mm (in)	40 (1.57)
Extended Stroke ES	mm (in)	100 (3.94)
Max. Force	N (lbf)	67 (15.1)
Cont. Force	N (lbf)	15 (3.5)
Cont. Force with fan	N (lbf)	25 (5.6)
Max. Velocity	m/s (in/s)	7.3 (287)
Max. Current	A	7.5
Cont. Current	A	1.5
Cont. Current with fan	A	2.2
Force Constant	N/A (lbf/A)	9 (2.0)
Border Force	%	63
Linearity	%	±0.1
Slider Length	mm (in)	170 (6.69)
Slider Mass	g (lb)	125 (0.28)

Ordering Information

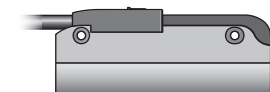

PS02-23Sx80F-HP-K	Stator HP with K-connector IP50	0150-1285
-------------------	---------------------------------	-----------



PL01-12x170/130-HP	High Performance Slider	0150-1529
PL02-12x170/130-HP	High Performance Slider, Heavy Duty	0150-1559

Max. Stroke: 130mm
Max. Force: 67N

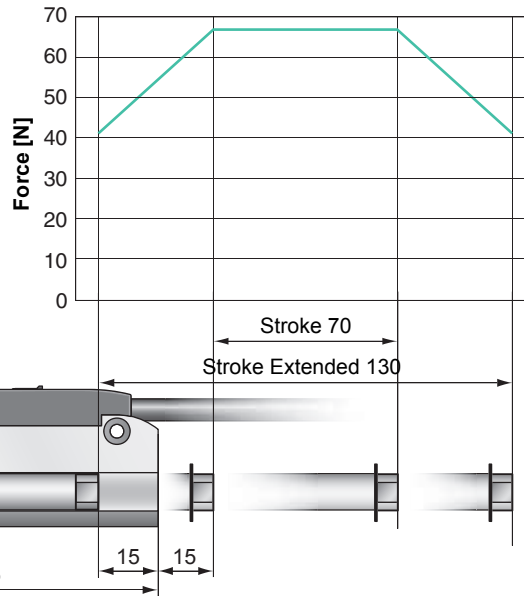

Dimensions in mm

Motor Specification

Stator Type		Standard Winding
Slider Type		High Performance High Performance Heavy Duty
Standard Stroke SS	mm (in)	70 (2.76)
Extended Stroke ES	mm (in)	130 (5.12)
Max. Force	N (lbf)	67 (15.1)
Cont. Force	N (lbf)	15 (3.5)
Cont. Force with fan	N (lbf)	25 (5.6)
Max. Velocity	m/s (in/s)	7.3 (287)
Max. Current	A	7.5
Cont. Current	A	1.5
Cont. Current with fan	A	2.2
Force Constant	N/A (lbf/A)	9 (2.0)
Border Force	%	63
Linearity	%	±0.1
Slider Length	mm (in)	200 (7.87)
Slider Mass	g (lb)	150 (0.33)

Ordering Information

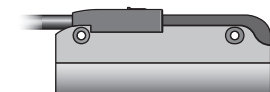

PS02-23Sx80F-HP-K	Stator HP with K-connector IP50	0150-1285
-------------------	---------------------------------	-----------



PL01-12x200/160-HP	High Performance Slider	0150-1518
PL02-12x200/160-HP	High Performance Slider, Heavy Duty	0150-1532

Max. Stroke: 160mm
Max. Force: 67N

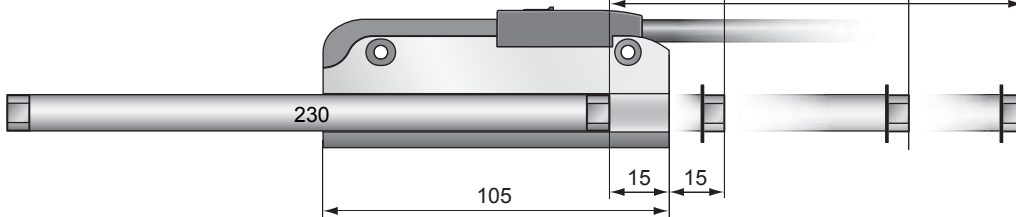
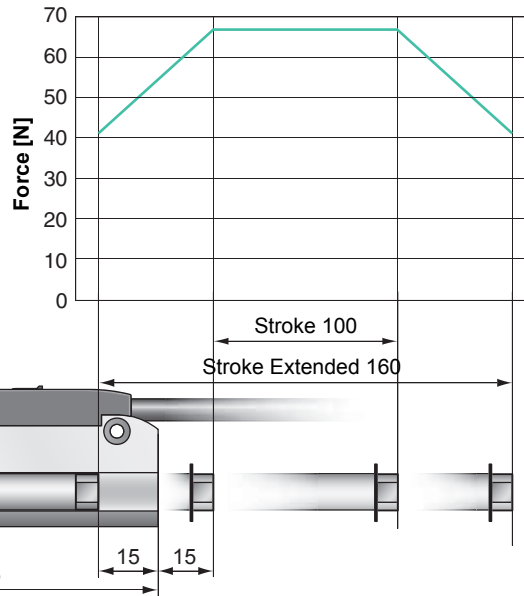

Dimensions in mm

Motor Specification

Stator Type		Standard Winding
Slider Type		High Performance High Performance Heavy Duty
Standard Stroke SS	mm (in)	100 (3.94)
Extended Stroke ES	mm (in)	160 (6.3)
Max. Force	N (lbf)	67 (15.1)
Cont. Force	N (lbf)	15 (3.5)
Cont. Force with fan	N (lbf)	25 (5.6)
Max. Velocity	m/s (in/s)	7.3 (287)
Max. Current	A	7.5
Cont. Current	A	1.5
Cont. Current with fan	A	2.2
Force Constant	N/A (lbf/A)	9 (2.0)
Border Force	%	63
Linearity	%	±0.1
Slider Length	mm (in)	230 (9.06)
Slider Mass	g (lb)	175 (0.39)

Ordering Information

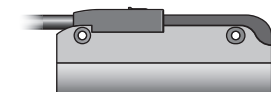

PS02-23Sx80F-HP-K	Stator HP with K-connector IP50	0150-1285
-------------------	---------------------------------	-----------



PL01-12x230/190-HP	High Performance Slider	0150-1519
PL02-12x230/190-HP	High Performance Slider, Heavy Duty	0150-1552

Max. Stroke: 200mm
Max. Force: 67N

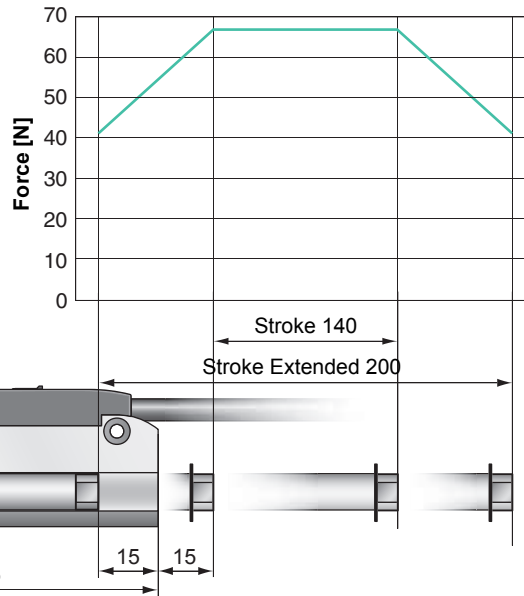

— E1100, 72VDC

Dimensions in mm

Motor Specification

Stator Type		Standard Winding
Slider Type		High Performance High Performance Heavy Duty
Standard Stroke SS	mm (in)	140 (5.51)
Extended Stroke ES	mm (in)	200 (7.87)
Max. Force	N (lbf)	67 (15.1)
Cont. Force	N (lbf)	15 (3.5)
Cont. Force with fan	N (lbf)	25 (5.6)
Max. Velocity	m/s (in/s)	7.3 (287)
Max. Current	A	7.5
Cont. Current	A	1.5
Cont. Current with fan	A	2.2
Force Constant	N/A (lbf/A)	9 (2.0)
Border Force	%	63
Linearity	%	±0.1
Slider Length	mm (in)	270 (16.63)
Slider Mass	g (lb)	210 (0.46)

Ordering Information

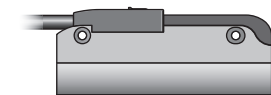

PS02-23Sx80F-HP-K	Stator HP with K-connector IP50	0150-1285
-------------------	---------------------------------	-----------



PL01-12x270/230-HP	High Performance Slider	0150-1520
PL02-12x270/230-HP	High Performance Slider, Heavy Duty	0150-1533

Max. Stroke: 220mm
Max. Force: 67N

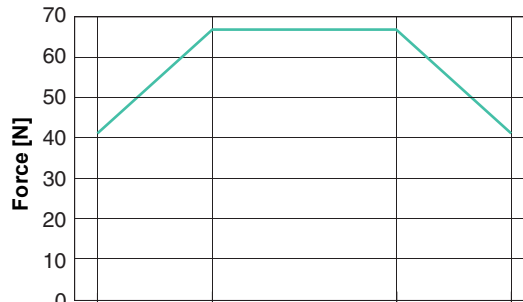

— E1100, 72VDC

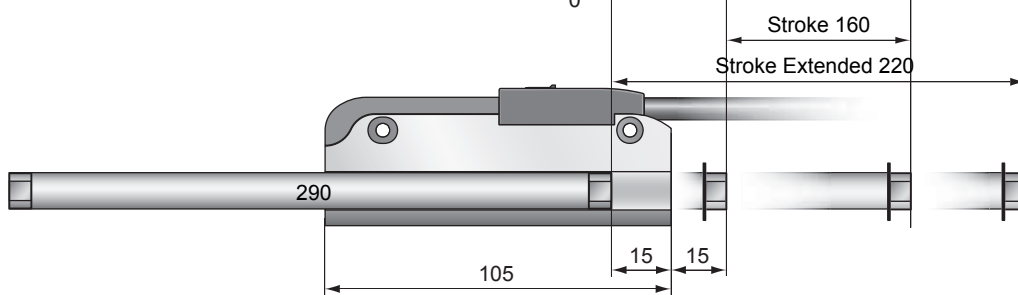

Dimensions in mm

Motor Specification

Stator Type		Standard Winding
Slider Type		High Performance High Performance Heavy Duty
Standard Stroke SS	mm (in)	160 (6.30)
Extended Stroke ES	mm (in)	220 (8.66)
Max. Force	N (lbf)	67 (15.1)
Cont. Force	N (lbf)	15 (3.5)
Cont. Force with fan	N (lbf)	25 (5.6)
Max. Velocity	m/s (in/s)	7.3 (287)
Max. Current	A	7.5
Cont. Current	A	1.5
Cont. Current with fan	A	2.2
Force Constant	N/A (lbf/A)	9 (2.0)
Border Force	%	63
Linearity	%	±0.1
Slider Length	mm (in)	290 (11.42)
Slider Mass	g (lb)	230 (0.51)

Ordering Information

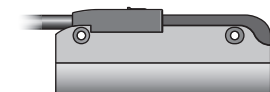

PS02-23Sx80F-HP-K	Stator HP with K-connector IP50	0150-1285
-------------------	---------------------------------	-----------



PL01-12x290/250-HP	High Performance Slider	0150-1521
PL02-12x290/250-HP	High Performance Slider, Heavy Duty	0150-1495

Max. Stroke: 280mm
Max. Force: 67N

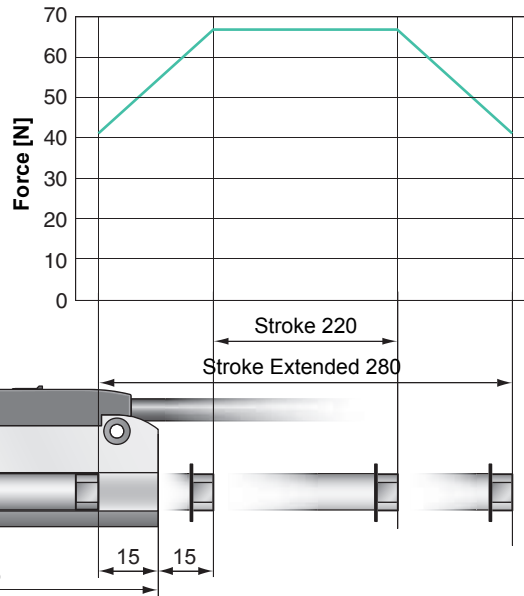

— E1100, 72VDC

Dimensions in mm

Motor Specification

Stator Type		Standard Winding
Slider Type		High Performance High Performance Heavy Duty
Standard Stroke SS	mm (in)	220 (8.66)
Extended Stroke ES	mm (in)	280 (11.02)
Max. Force	N (lbf)	67 (15.1)
Cont. Force	N (lbf)	15 (3.5)
Cont. Force with fan	N (lbf)	25 (5.6)
Max. Velocity	m/s (in/s)	7.3 (287)
Max. Current	A	7.5
Cont. Current	A	1.5
Cont. Current with fan	A	2.2
Force Constant	N/A (lbf/A)	9 (2.0)
Border Force	%	63
Linearity	%	±0.1
Slider Length	mm (in)	350 (13.78)
Slider Mass	g (lb)	280 (0.62)

Ordering Information

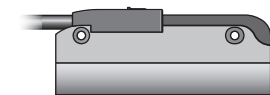

PS02-23Sx80F-HP-K	Stator HP with K-connector IP50	0150-1285
-------------------	---------------------------------	-----------



PL01-12x350/310-HP	High Performance Slider	0150-1522
PL02-12x350/310-HP	High Performance Slider, Heavy Duty	0150-1555

Max. Stroke: 350mm
Max. Force: 67N

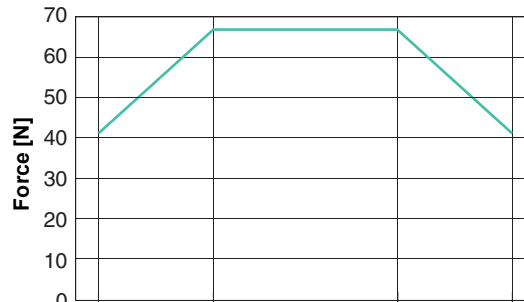

— E1100, 72VDC

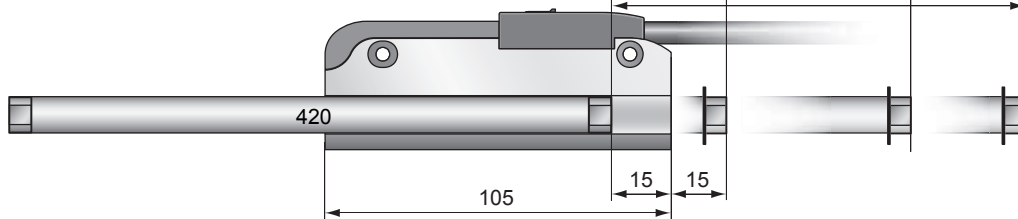

Dimensions in mm

Motor Specification

Stator Type		Standard Winding
Slider Type		High Performance High Performance Heavy Duty
Standard Stroke SS	mm (in)	290 (11.42)
Extended Stroke ES	mm (in)	350 (13.78)
Max. Force	N (lbf)	67 (15.1)
Cont. Force	N (lbf)	15 (3.5)
Cont. Force with fan	N (lbf)	25 (5.6)
Max. Velocity	m/s (in/s)	7.3 (287)
Max. Current	A	7.5
Cont. Current	A	1.5
Cont. Current with fan	A	2.2
Force Constant	N/A (lbf/A)	9 (2.0)
Border Force	%	63
Linearity	%	±0.1
Slider Length	mm (in)	420 (16.53)
Slider Mass	g (lb)	340 (0.75)

Ordering Information

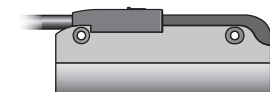

PS02-23Sx80F-HP-K	Stator HP with K-connector IP50	0150-1285
-------------------	---------------------------------	-----------



PL01-12x420/380-HP	High Performance Slider	0150-1523
PL02-12x420/38-HP	High Performance Slider, Heavy Duty	0150-1554

Max. Stroke: 410mm
Max. Force: 67N

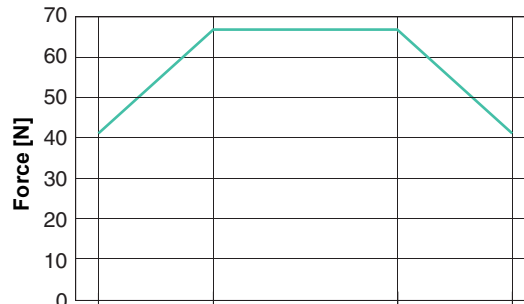

— E1100, 72VDC

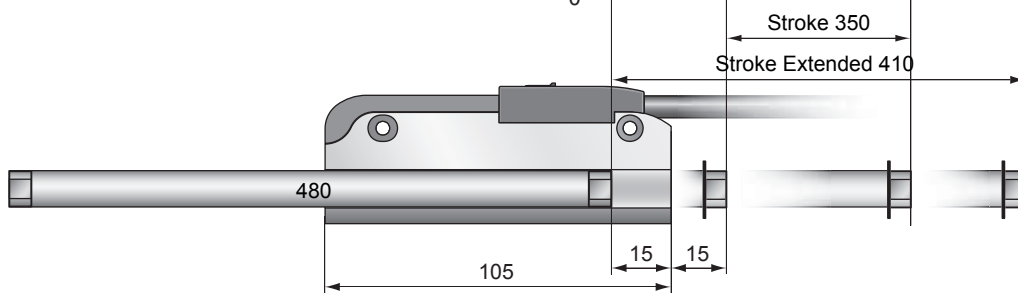

Dimensions in mm

Motor Specification

Stator Type		Standard Winding
Slider Type		High Performance High Performance Heavy Duty
Standard Stroke SS	mm (in)	350 (13.78)
Extended Stroke ES	mm (in)	410 (16.14)
Max. Force	N (lbf)	67 (15.1)
Cont. Force	N (lbf)	15 (3.5)
Cont. Force with fan	N (lbf)	25 (5.6)
Max. Velocity	m/s (in/s)	7.3 (287)
Max. Current	A	7.5
Cont. Current	A	1.5
Cont. Current with fan	A	2.2
Force Constant	N/A (lbf/A)	9 (2.0)
Border Force	%	63
Linearity	%	±0.1
Slider Length	mm (in)	480 (18.90)
Slider Mass	g (lb)	390 (0.86)

Ordering Information

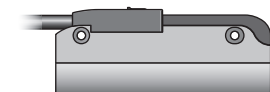

PS02-23Sx80F-HP-K	Stator HP with K-connector IP50	0150-1285
-------------------	---------------------------------	-----------



PL01-12x480/440-HP	High Performance Slider	0150-1524
PL02-12x480/440-HP	High Performance Slider, Heavy Duty	on request

Max. Stroke: 510mm
Max. Force: 67N

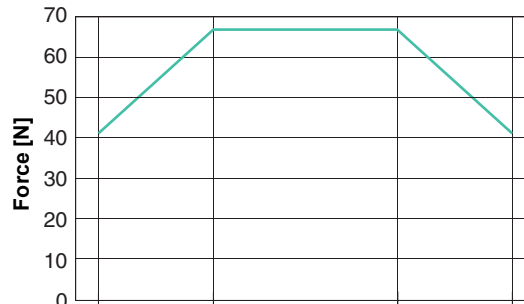

— E1100, 72VDC

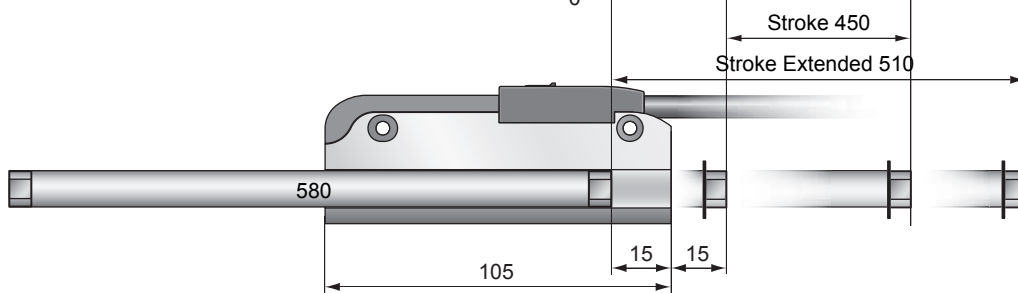

Dimensions in mm

Motor Specification

Stator Type		Standard Winding
Slider Type		High Performance High Performance Heavy Duty
Standard Stroke SS	mm (in)	450 (17.72)
Extended Stroke ES	mm (in)	510 (20.08)
Max. Force	N (lbf)	67 (15.1)
Cont. Force	N (lbf)	15 (3.5)
Cont. Force with fan	N (lbf)	25 (5.6)
Max. Velocity	m/s (in/s)	7.3 (287)
Max. Current	A	7.5
Cont. Current	A	1.5
Cont. Current with fan	A	2.2
Force Constant	N/A (lbf/A)	9 (2.0)
Border Force	%	63
Linearity	%	±0.1
Slider Length	mm (in)	580 (22.83)
Slider Mass	g (lb)	475 (1.05)

Ordering Information

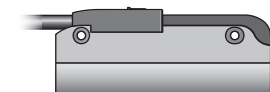

PS02-23Sx80F-HP-K	Stator HP with K-connector IP50	0150-1285
-------------------	---------------------------------	-----------



PL01-12x580/540-HP	High Performance Slider	0150-1525
PL02-12x580/540-HP	High Performance Slider, Heavy Duty	on request

Max. Stroke: 690mm
Max. Force: 67N

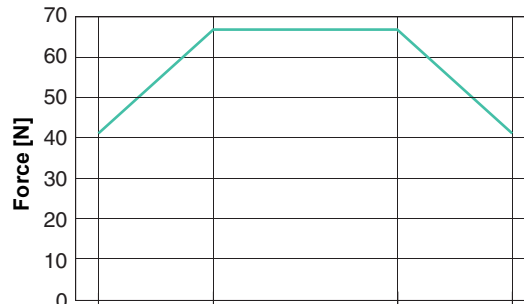

— E1100, 72VDC

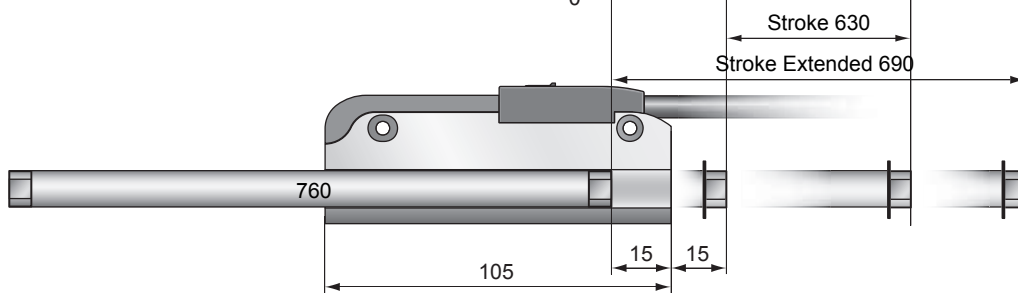

Dimensions in mm

Motor Specification

Stator Type		Standard Winding
Slider Type		High Performance High Performance Heavy Duty
Standard Stroke SS	mm (in)	630 (24.80)
Extended Stroke ES	mm (in)	690 (27.17)
Max. Force	N (lbf)	67 (15.1)
Cont. Force	N (lbf)	15 (3.5)
Cont. Force with fan	N (lbf)	25 (5.6)
Max. Velocity	m/s (in/s)	7.3 (287)
Max. Current	A	7.5
Cont. Current	A	1.5
Cont. Current with fan	A	2.2
Force Constant	N/A (lbf/A)	9 (2.0)
Border Force	%	63
Linearity	%	±0.1
Slider Length	mm (in)	760 (29.92)
Slider Mass	g (lb)	625 (1.38)

Ordering Information

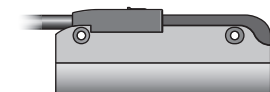

PS02-23Sx80F-HP-K	Stator HP with K-connector IP50	0150-1285
-------------------	---------------------------------	-----------



PL01-12x760/720-HP	High Performance Slider	0150-1526
PL02-12x760/720-HP	High Performance Slider, Heavy Duty	on request

Max. Stroke: 780mm
Max. Force: 67N

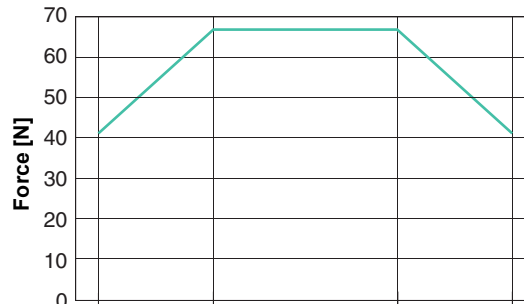

— E1100, 72VDC

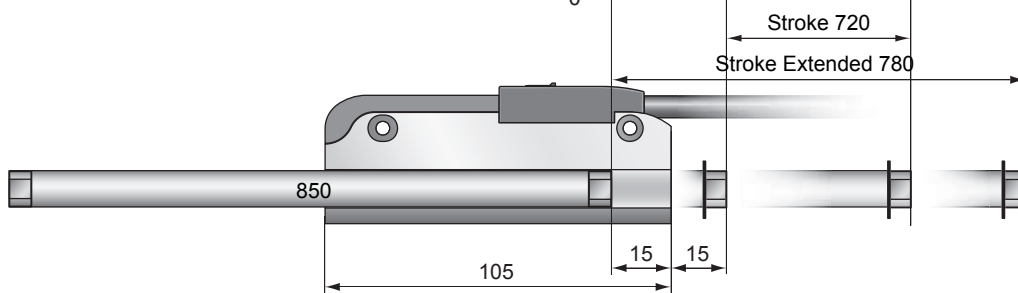

Dimensions in mm

Motor Specification

Stator Type		Standard Winding
Slider Type		High Performance High Performance Heavy Duty
Standard Stroke SS	mm (in)	720 (28.35)
Extended Stroke ES	mm (in)	780 (30.71)
Max. Force	N (lbf)	67 (15.1)
Cont. Force	N (lbf)	15 (3.5)
Cont. Force with fan	N (lbf)	25 (5.6)
Max. Velocity	m/s (in/s)	7.3 (287)
Max. Current	A	7.5
Cont. Current	A	1.5
Cont. Current with fan	A	2.2
Force Constant	N/A (lbf/A)	9 (2.0)
Border Force	%	63
Linearity	%	±0.1
Slider Length	mm (in)	850 (33.46)
Slider Mass	g (lb)	700 (1.54)

Ordering Information

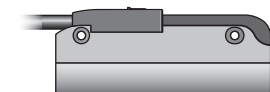

PS02-23Sx80F-HP-K	Stator HP with K-connector IP50	0150-1285
-------------------	---------------------------------	-----------



PL01-12x850/810-HP	High Performance Slider	0150-1527
PL02-12x850/810-HP	High Performance Slider, Heavy Duty	on request

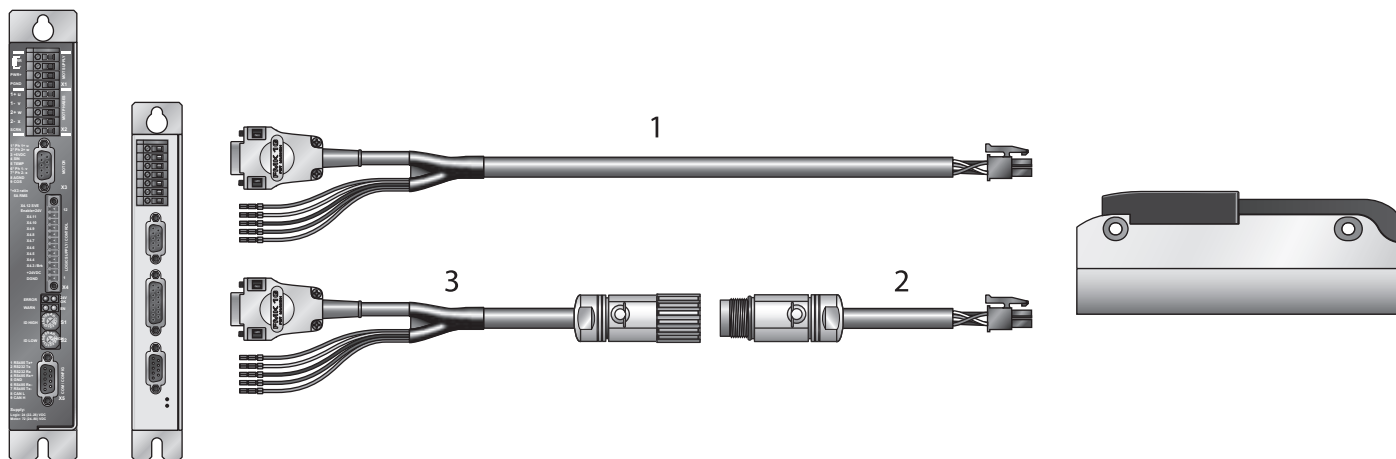

K-Connector

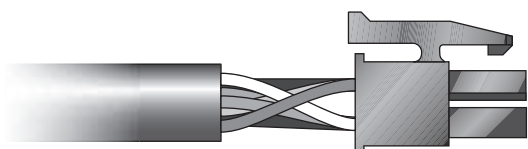

K/f

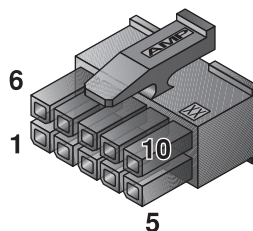

Motor Connector Wiring

Pin 1	red	Phase 1+
Pin 2	blue	Phase 2+
Pin 3		n.c.
Pin 4	pink	Phase 1-
Pin 5	grey	Phase 2-
Pin 6	yellow	Sensor Sin
Pin 7	green	Sensor Cos
Pin 8	brown	Ground
Pin 9	white	+5V
Pin 10	black	Temp sensor
shield	case	Shield

Ordering Information

1. High Flex Motor Cable directly to the Controller (length up to 2m)

Item	Description	Part Number
KS03-W/K-2	High Flex cable W/K, 2m	0150-2187
KS03-W/K-	High Flex cable W/K, custom length	0150-3357

2. High Flex Motor Cable with R Connector (length up to 2m)

KS03-R/K-1	High Flex cable R/K, 1m	0150-2185
KS03-R/K-2	High Flex cable R/K, 2m	0150-2186
KS03-R/K-	High Flex cable R/K, custom length	0150-3353

3. Motor Extension Cables (length up to 50m)

Standard cable		
K05-W/R-2	Standard cable W/R, 2m	0150-2119
K05-W/R-4	Standard cable W/R, 4m	0150-2120
K05-W/R-6	Standard cable W/R, 6m	0150-2121
K05-W/R-8	Standard cable W/R, 8m	0150-2122
K05-W/R-10	Standard cable W/R, 10m	0150-2132
K05-W/R-	Standard cable W/R, custom length	0150-3262

High Flex cable chain cable

KS05-W/R-4	High Flex cable W/R, 4m	0150-2106
KS05-W/R-6	High Flex cable W/R, 6m	0150-2131
KS05-W/R-8	High Flex cable W/R, 8m	0150-2107
KS05-W/R-	High Flex cable W/R, custom length	0150-3256

Connectors & Cable

KS03--09	High Flex cable per m	0150-2182
KR05-W/R-	Robot cable W/R, per m	0150-3336
MC01-K/f	K/f connector	0150-3345
MC01-K/f-as	K/f connector, assembled	0150-3346

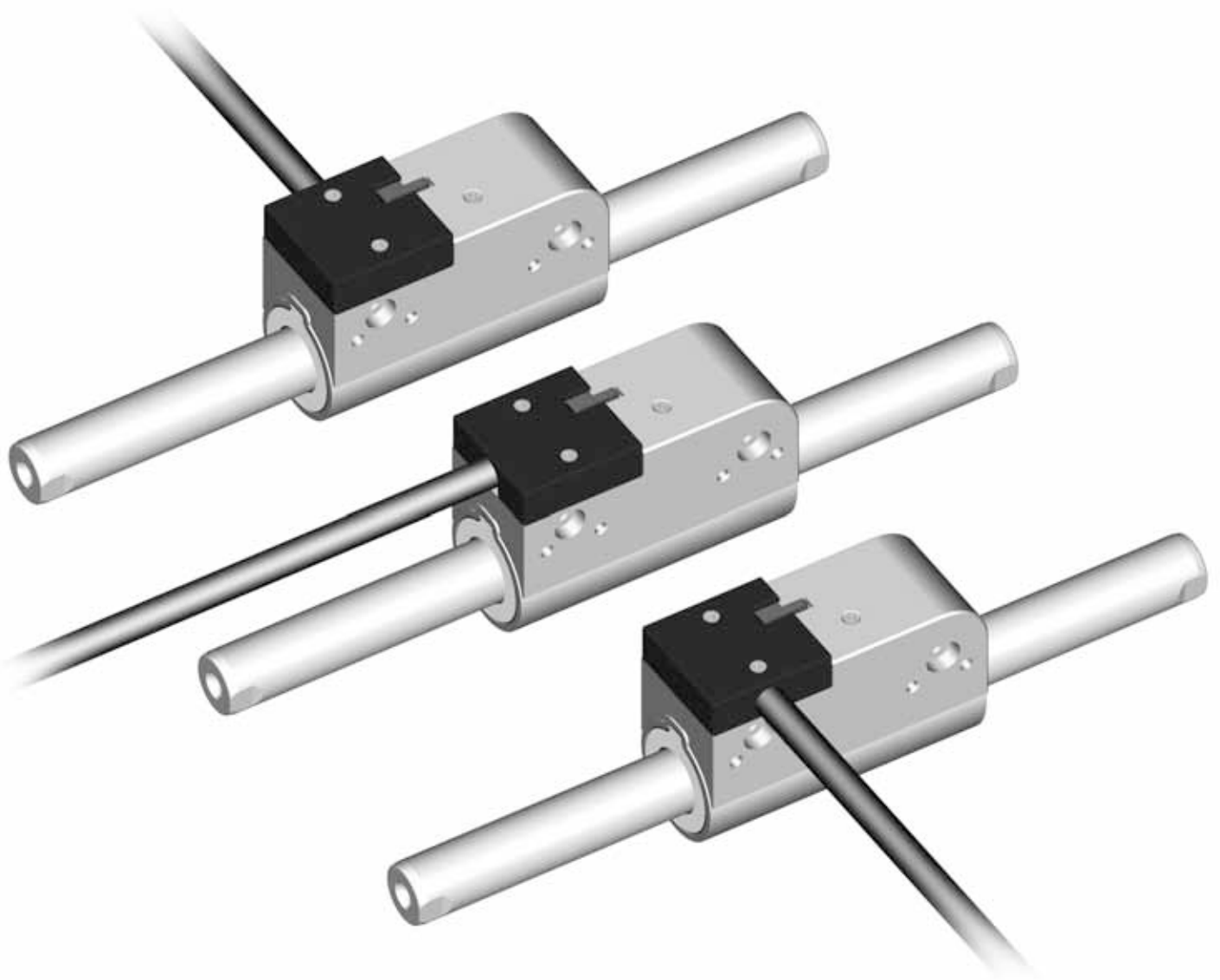

Series P01-37Sx60-HP	242	P01-37Sx60/560x580-HP	251
P01-37Sx60/100x120-HP	245	P01-37Sx60/660x680-HP	252
P01-37Sx60/160x180-HP	246	P01-37Sx60/760x780-HP	253
P01-37Sx60/220x240-HP	247	P01-37Sx60/860x880-HP	254
P01-37Sx60/260x280-HP	248	P01-37Sx60/1060x1080-HP	255
P01-37Sx60/360x380-HP	249	P01-37Sx60/1260x1280-HP	256
P01-37Sx60/460x480-HP	250	P01-37Sx60/1460x1480-HP	257
		Motor Cable	258

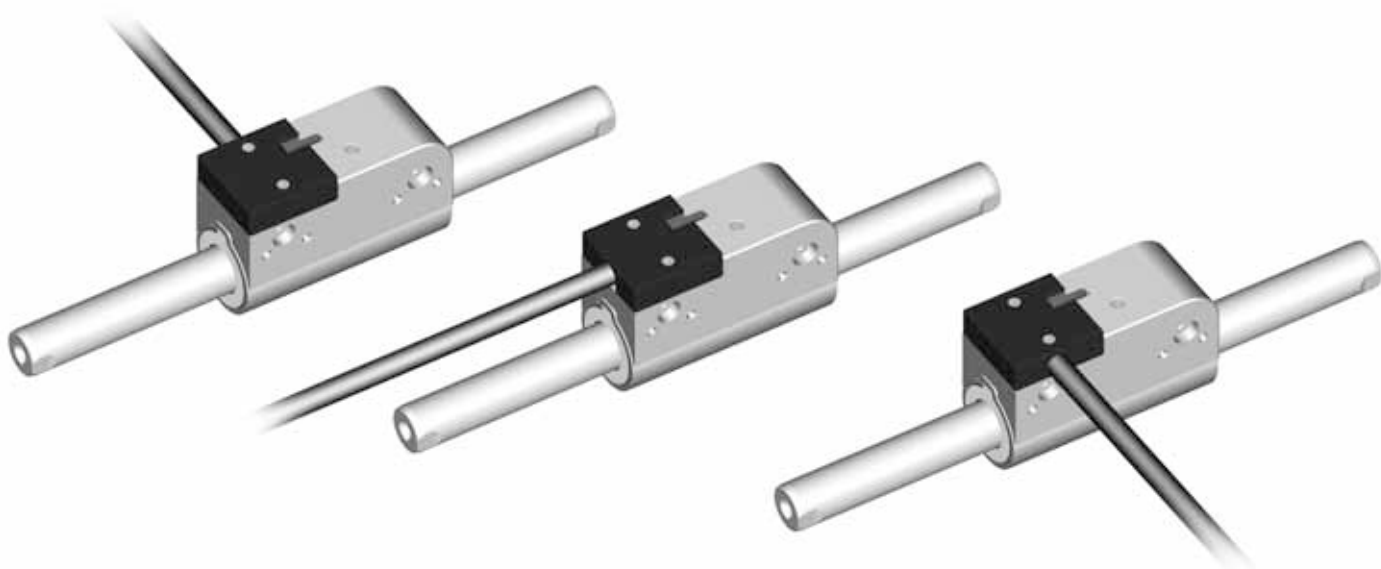

Motor Specification

		P01-37Sx60-HP/...
Maximum Stroke	mm (in)	1480 (58.27)
Maximum Force	N (lbf)	122 (28.6)
Maximum Velocity	m/s (in/s)	5 (196)
Max. Current	A	12.0
Cont. Current	A	3.0
Phase Resist. 25 °C	Ohm	3.1
Phase Resist. 80 °C	Ohm	3.7
Phase Inductance	mH	1.6
Thermal Resistance	°K/W	2.2
Thermal Time Const.	sec	3800
Stator Diameter	mm (in)	37 (1.46) / 38 (1.50)
Stator Length	mm (in)	90 (3.54)
Stator Mass	g (lb)	513 (1.13)
Slider Diameter	mm (in)	20 (0.79)
Position Resolution	mm (in)	0,01
Position Repeatability	mm (in)	±0.05 (±0.0020)
Position Resolution ES	mm (in)	0,001
Repeatability with EPS	mm (in)	±0.01 (±0.0004)

Accessories



Servo Drive:
E1100



E1200



B1100-HC

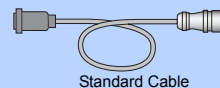

Standard Cable

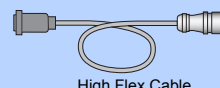

High Flex Cable



Robotic Cable

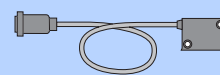

Optional Linear Encoder

Stator

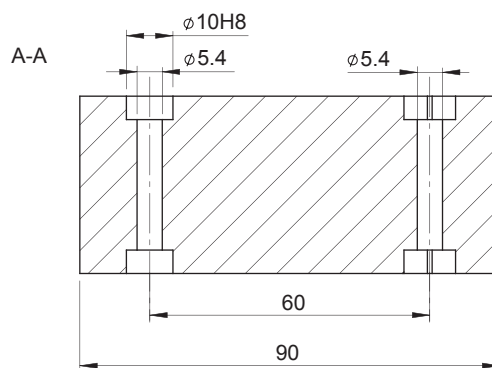
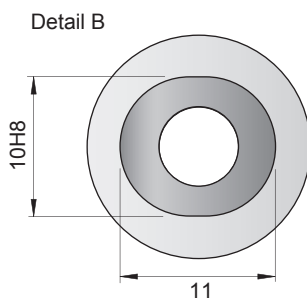
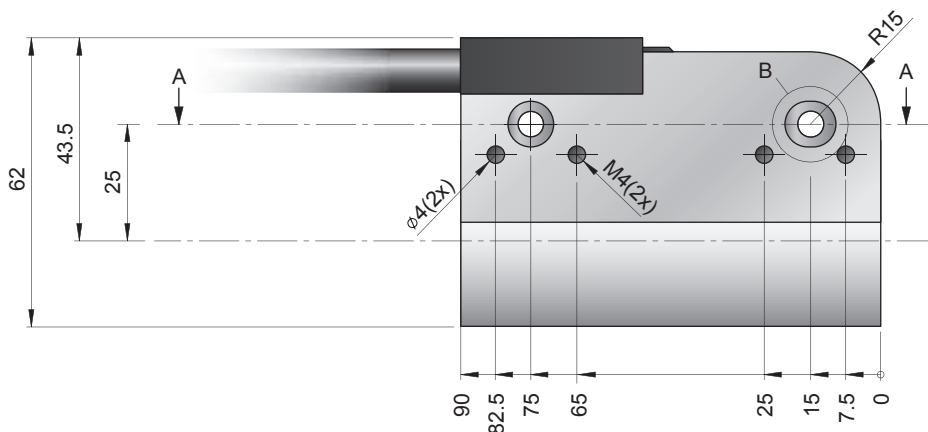
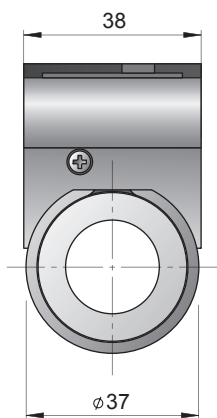

N-Connector

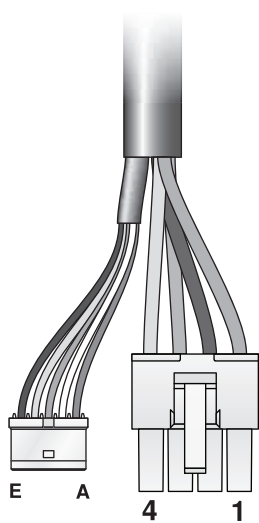

Motor Connector Wiring

Pin 1	red	Phase 1+
Pin 2	pink	Phase 1-
Pin 3	blue	Phase 2+
Pin 4	grey	Phase 2-

Pin A	white	+5V
Pin B	inner Shield	Ground
Pin C	yellow	Sensor Sin
Pin D	green	Sensor Cos
Pin E	black	Temp sensor
case	outer Shield	shield

Stators are shipped with three covers for left/right/straight cable outlet

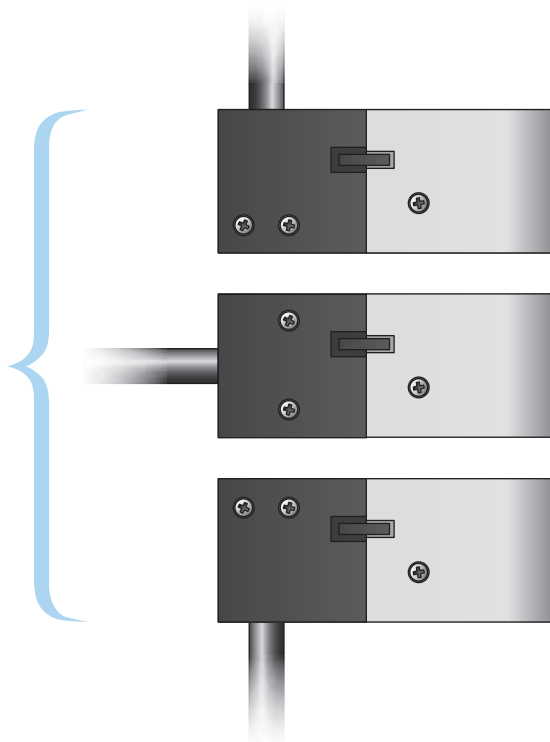

Ordering Information

Item	Description	Part Number
PS01-37Sx60-HP-N	Stator HP with N-connector IP50	0150-1295

Sliders

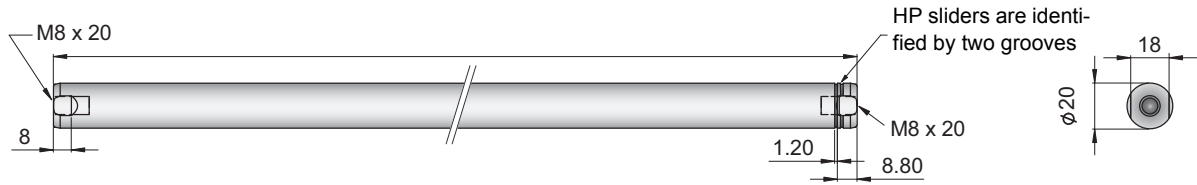

High Performance Slider		Length[mm]	Stroke[mm]	Part Number
PL01-20x240/180-HP	slider "High Performance"	240	100x120	0150-1505
PL01-20x300/240-HP	slider "High Performance"	300	160x180	0150-1506
PL01-20x360/300-HP	slider "High Performance"	360	220x240	0150-1507
PL01-20x400/340-HP	slider "High Performance"	400	260x280	0150-1508
PL01-20x500/440-HP	slider "High Performance"	500	360x380	0150-1509
PL01-20x600/540-HP	slider "High Performance"	600	460x480	0150-1510
PL01-20x700/640-HP	slider "High Performance"	700	560x580	0150-1511
PL01-20x800/740-HP	slider "High Performance"	800	660x680	0150-1512
PL01-20x900/840-HP	slider "High Performance"	900	760x780	0150-1513
PL01-20x1000/940-HP	slider "High Performance"	1000	860x880	0150-1514
PL01-20x1200/1140-HP	slider "High Performance"	1200	1060x1080	0150-1515
PL01-20x1400/1340-HP	slider "High Performance"	1400	1260x1280	0150-1516
PL01-20x1600/1540-HP	slider "High Performance"	1600	1460x1480	0150-1517

Max. Stroke: 120mm
Max. Force: 122N

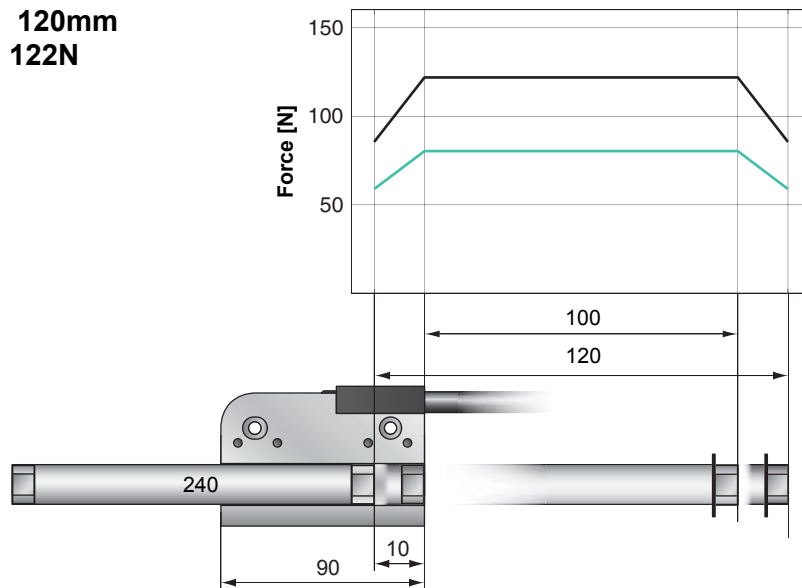

— E1100-HC, 72VDC
 — E1100, 72VDC

Dimensions in mm

Motor Specification

Stator		Standard Winding
Slider		High Performance High Performance Heavy Duty
Standard Stroke SS	mm (in)	100 (3.94)
Extended Stroke ES	mm (in)	120 (4.72)
Max. Force	N (lbf)	122 (28.6)
Cont. Force	N (lbf)	20 (4.50)
Cont. Force with fan	N (lbf)	35 (7.87)
Max. Velocity	m/s (in/s)	5.0
Max. Current	A	12.0
Cont. Current	A	3.0
Cont. Current with fan	A	5.0
Force Constant	N/A (lbf/A)	10.2 (2.30)
Border Force	%	67
Linearity	%	±0.1
Slider Length	mm (in)	240 (9.45)
Slider Mass	g (lb)	530 (1.17)

Ordering Information



PS01-37Sx60-HP-N	Stator HP with N-connector IP50	0150-1295
------------------	---------------------------------	-----------



PL01-20x240/180-HP	High Performance Slider	0150-1505
PL02-20x240/180-HP	High Performance Slider, Heavy Duty	on request

Max. Stroke: 180mm
 Max. Force: 122N

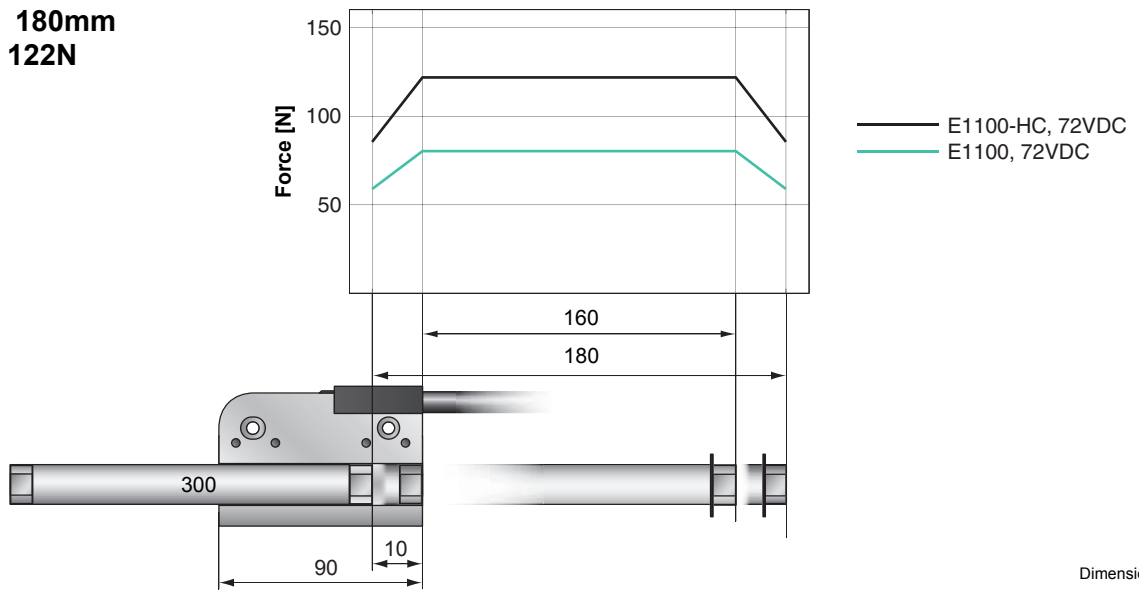

Dimensions in mm

Motor Specification		
Stator	Standard Winding	
Slider	High Performance	
	High Performance Heavy Duty	
Standard Stroke SS	mm (in)	160 (6.30)
Extended Stroke ES	mm (in)	180 (7.09)
Max. Force	N (lbf)	122 (28.6)
Cont. Force	N (lbf)	20 (4.50)
Cont. Force with fan	N (lbf)	35 (7.87)
Max. Velocity	m/s (in/s)	5.0
Max. Current	A	12.0
Cont. Current	A	3.0
Cont. Current with fan	A	5.0
Force Constant	N/A (lbf/A)	10.2 (2.30)
Border Force	%	67
Linearity	%	±0.1
Slider Length	mm (in)	300 (11.81)
Slider Mass	g (lb)	650 (1.43)

Ordering Information

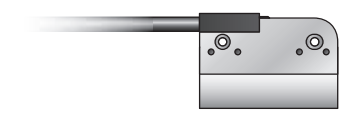

PS01-37Sx60-HP-N	Stator HP with N-connector IP50	0150-1295
------------------	---------------------------------	-----------



PL01-20x300/240-HP	High Performance Slider	0150-1506
PL02-20x300/240-HP	High Performance Slider, Heavy Duty	on request

Max. Stroke: 240mm
Max. Force: 122N

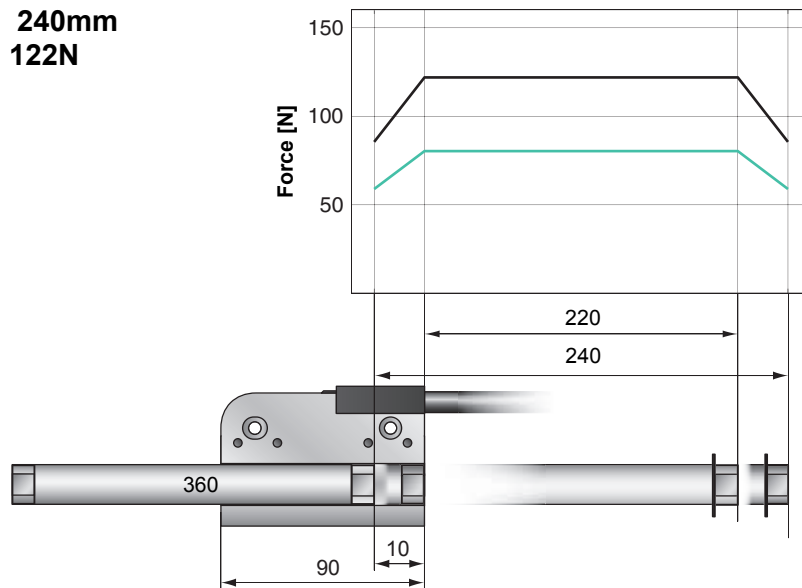

— E1100-HC, 72VDC
 — E1100, 72VDC

Dimensions in mm

Motor Specification

Stator		Standard Winding
Slider		High Performance High Performance Heavy Duty
Standard Stroke SS	mm (in)	220 (8.66)
Extended Stroke ES	mm (in)	240 (9.45)
Max. Force	N (lbf)	122 (28.6)
Cont. Force	N (lbf)	20 (4.50)
Cont. Force with fan	N (lbf)	35 (7.87)
Max. Velocity	m/s (in/s)	5.0
Max. Current	A	12.0
Cont. Current	A	3.0
Cont. Current with fan	A	5.0
Force Constant	N/A (lbf/A)	10.2 (2.30)
Border Force	%	67
Linearity	%	±0.1
Slider Length	mm (in)	360 (14.17)
Slider Mass	g (lb)	800 (1.76)

Ordering Information



PS01-37Sx60-HP-N	Stator HP with N-connector IP50	0150-1295
------------------	---------------------------------	-----------



PL01-20x360/300-HP	High Performance Slider	0150-1507
PL02-20x360/300-HP	High Performance Slider, Heavy Duty	on request

Max. Stroke: 280mm
Max. Force: 122N

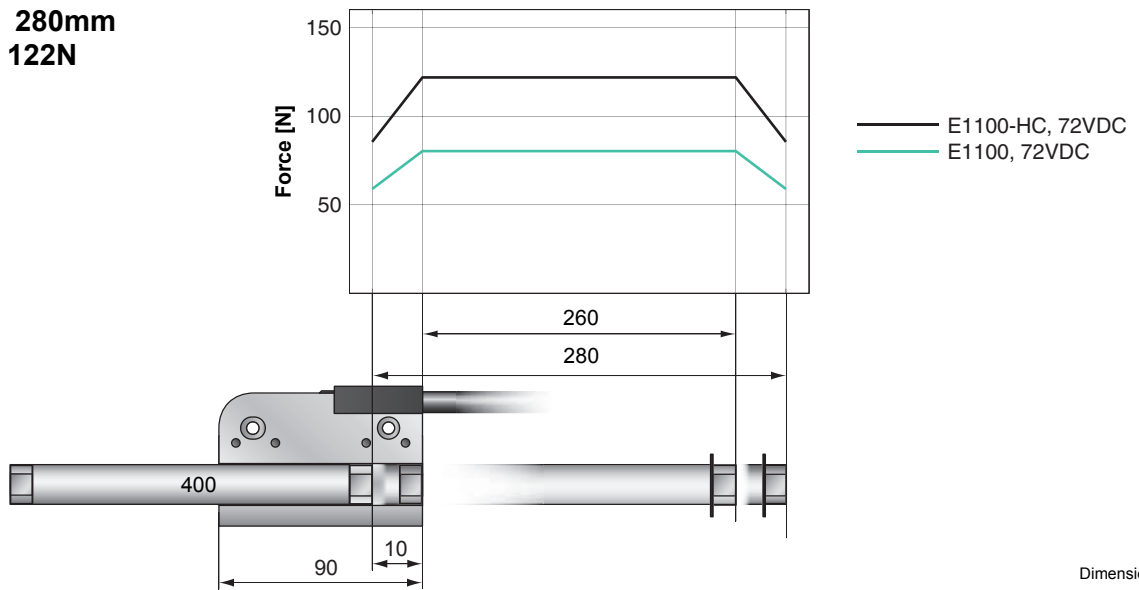

Dimensions in mm

Motor Specification

Stator		Standard Winding
Slider		High Performance High Performance Heavy Duty
Standard Stroke SS	mm (in)	260 (10.24)
Extended Stroke ES	mm (in)	280 (11.02)
Max. Force	N (lbf)	122 (28.6)
Cont. Force	N (lbf)	20 (4.50)
Cont. Force with fan	N (lbf)	35 (7.87)
Max. Velocity	m/s (in/s)	5.0
Max. Current	A	12.0
Cont. Current	A	3.0
Cont. Current with fan	A	5.0
Force Constant	N/A (lbf/A)	10.2 (2.30)
Border Force	%	67
Linearity	%	±0.1
Slider Length	mm (in)	400 (15.75)
Slider Mass	g (lb)	880 (1.94)

Ordering Information



PS01-37Sx60-HP-N	Stator HP with N-connector IP50	0150-1295
------------------	---------------------------------	-----------



PL01-20x400/340-HP	High Performance Slider	0150-1508
PL02-20x400/340-HP	High Performance Slider, Heavy Duty	on request

Max. Stroke: 380mm
Max. Force: 122N

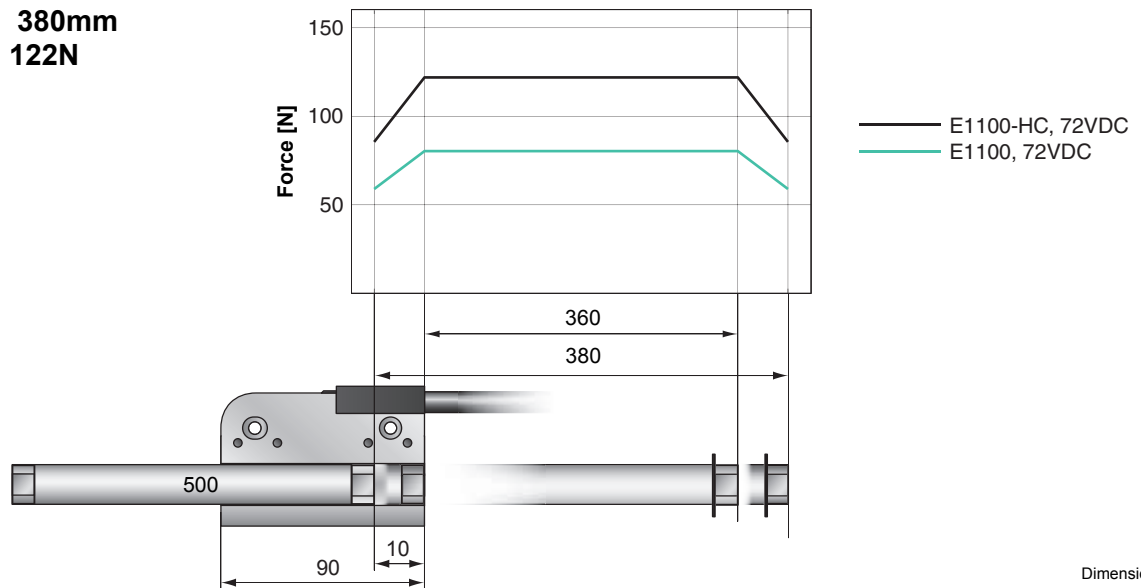

Motor Specification

Stator		Standard Winding
Slider		High Performance High Performance Heavy Duty
Standard Stroke SS	mm (in)	360 (14.17)
Extended Stroke ES	mm (in)	380 (14.96)
Max. Force	N (lbf)	122 (28.6)
Cont. Force	N (lbf)	20 (4.50)
Cont. Force with fan	N (lbf)	35 (7.87)
Max. Velocity	m/s (in/s)	5.0
Max. Current	A	12.0
Cont. Current	A	3.0
Cont. Current with fan	A	5.0
Force Constant	N/A (lbf/A)	10.2 (2.30)
Border Force	%	67
Linearity	%	±0.1
Slider Length	mm (in)	500 (19.69)
Slider Mass	g (lb)	1110 (2.45)

Ordering Information



PS01-37Sx60-HP-N	Stator HP with N-connector IP50	0150-1295
------------------	---------------------------------	-----------



PL01-20x500/440-HP	High Performance Slider	0150-1509
PL02-20x500/440-HP	High Performance Slider, Heavy Duty	on request

Max. Stroke: 480mm
Max. Force: 122N

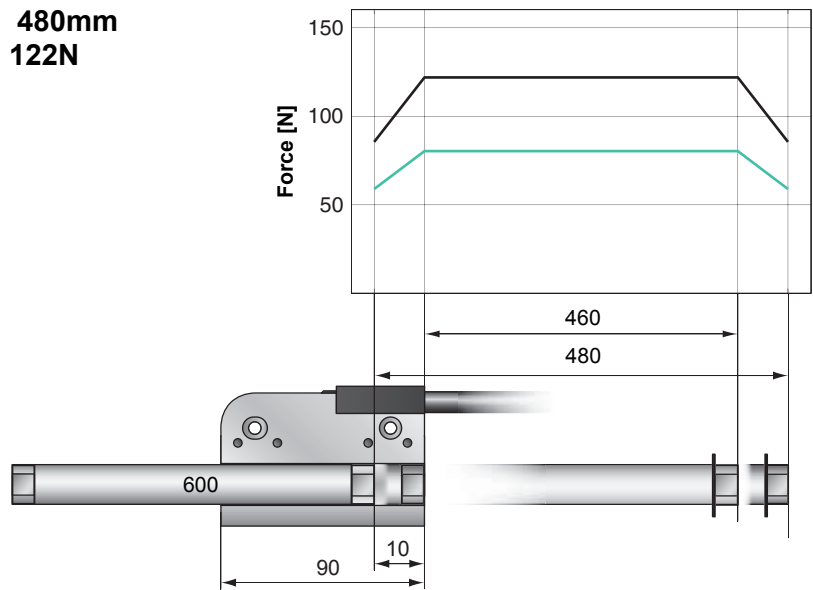

— E1100-HC, 72VDC
 — E1100, 72VDC

Dimensions in mm

Motor Specification

Stator		Standard Winding
Slider		High Performance High Performance Heavy Duty
Standard Stroke SS	mm (in)	460 (18.11)
Extended Stroke ES	mm (in)	480 (18.90)
Max. Force	N (lbf)	122 (28.6)
Cont. Force	N (lbf)	20 (4.50)
Cont. Force with fan	N (lbf)	35 (7.87)
Max. Velocity	m/s (in/s)	5.0
Max. Current	A	12.0
Cont. Current	A	3.0
Cont. Current with fan	A	5.0
Force Constant	N/A (lbf/A)	10.2 (2.30)
Border Force	%	67
Linearity	%	±0.1
Slider Length	mm (in)	600 (23.62)
Slider Mass	g (lb)	1350 (2.98)

Ordering Information



PS01-37Sx60-HP-N	Stator HP with N-connector IP50	0150-1295
------------------	---------------------------------	-----------



PL01-20x600/540-HP	High Performance Slider	0150-1510
PL02-20x600/540-HP	High Performance Slider, Heavy Duty	on request

Max. Stroke: 580mm
Max. Force: 122N

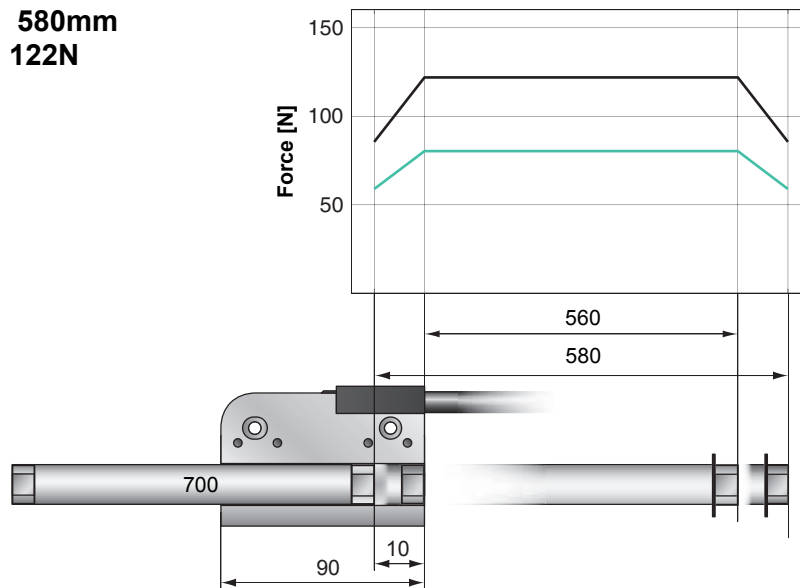

— E1100-HC, 72VDC
 — E1100, 72VDC

Dimensions in mm

Motor Specification

Stator		Standard Winding	
		High Performance	High Performance Heavy Duty
Standard Stroke SS	mm (in)	560 (22.05)	
Extended Stroke ES	mm (in)	580 (22.83)	
Max. Force	N (lbf)	122 (28.6)	
Cont. Force	N (lbf)	20 (4.50)	
Cont. Force with fan	N (lbf)	35 (7.87)	
Max. Velocity	m/s (in/s)	5.0	
Max. Current	A	12.0	
Cont. Current	A	3.0	
Cont. Current with fan	A	5.0	
Force Constant	N/A (lbf/A)	10.2 (2.30)	
Border Force	%	67	
Linearity	%	±0.1	
Slider Length	mm (in)	700 (27.56)	
Slider Mass	g (lb)	1580 (3.48)	

Ordering Information



PS01-37Sx60-HP-N	Stator HP with N-connector IP50	0150-1295
------------------	---------------------------------	-----------



PL01-20x700/640-HP	High Performance Slider	0150-1511
PL02-20x700/640-HP	High Performance Slider, Heavy Duty	on request

Max. Stroke: 680mm
Max. Force: 122N

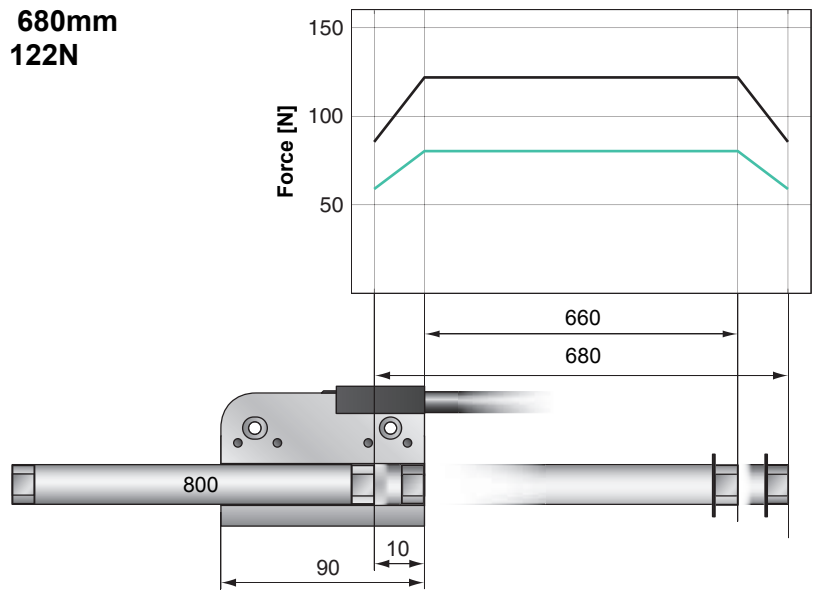

— E1100-HC, 72VDC
 — E1100, 72VDC

Dimensions in mm

Motor Specification

Stator		Standard Winding
Slider		High Performance High Performance Heavy Duty
Standard Stroke SS	mm (in)	660 (25.98)
Extended Stroke ES	mm (in)	680 (26.77)
Max. Force	N (lbf)	122 (28.6)
Cont. Force	N (lbf)	20 (4.50)
Cont. Force with fan	N (lbf)	35 (7.87)
Max. Velocity	m/s (in/s)	5.0
Max. Current	A	12.0
Cont. Current	A	3.0
Cont. Current with fan	A	5.0
Force Constant	N/A (lbf/A)	10.2 (2.30)
Border Force	%	67
Linearity	%	±0.1
Slider Length	mm (in)	800 (31.50)
Slider Mass	g (lb)	1810 (3.99)

Ordering Information



PS01-37Sx60-HP-N	Stator HP with N-connector IP50	0150-1295
------------------	---------------------------------	-----------



PL01-20x800/740-HP	High Performance Slider	0150-1512
PL02-20x800/740-HP	High Performance Slider, Heavy Duty	on request

Max. Stroke: 780mm
Max. Force: 122N

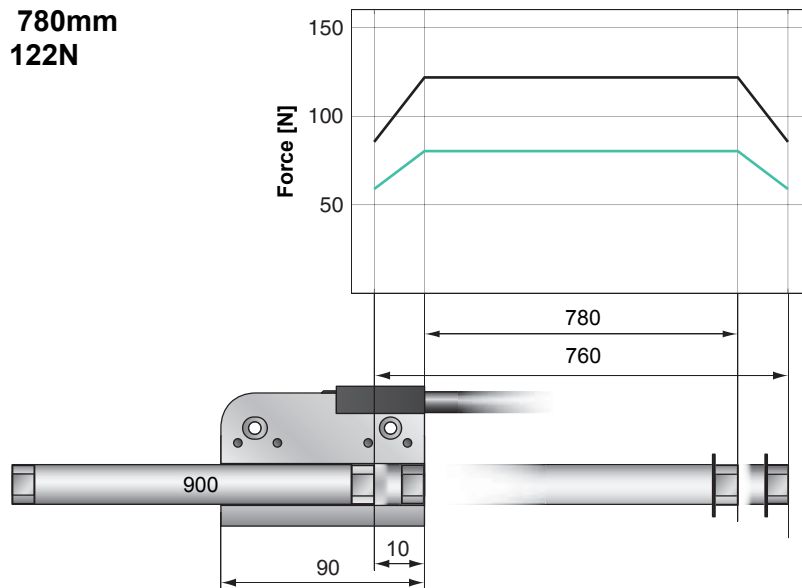

— E1100-HC, 72VDC
 — E1100, 72VDC

Dimensions in mm

Motor Specification

Stator		Standard Winding
Slider		High Performance High Performance Heavy Duty
Standard Stroke SS	mm (in)	760 (29.92)
Extended Stroke ES	mm (in)	780 (30.71)
Max. Force	N (lbf)	122 (28.6)
Cont. Force	N (lbf)	20 (4.50)
Cont. Force with fan	N (lbf)	35 (7.87)
Max. Velocity	m/s (in/s)	5.0
Max. Current	A	12.0
Cont. Current	A	3.0
Cont. Current with fan	A	5.0
Force Constant	N/A (lbf/A)	10.2 (2.30)
Border Force	%	67
Linearity	%	±0.1
Slider Length	mm (in)	900 (35.43)
Slider Mass	g (lb)	2040 (4.50)

Ordering Information



PS01-37Sx60-HP-N	Stator HP with N-connector IP50	0150-1295
------------------	---------------------------------	-----------



PL01-20x900/840-HP	High Performance Slider	0150-1513
PL02-20x900/840-HP	High Performance Slider, Heavy Duty	on request

Max. Stroke: 880mm
Max. Force: 122N

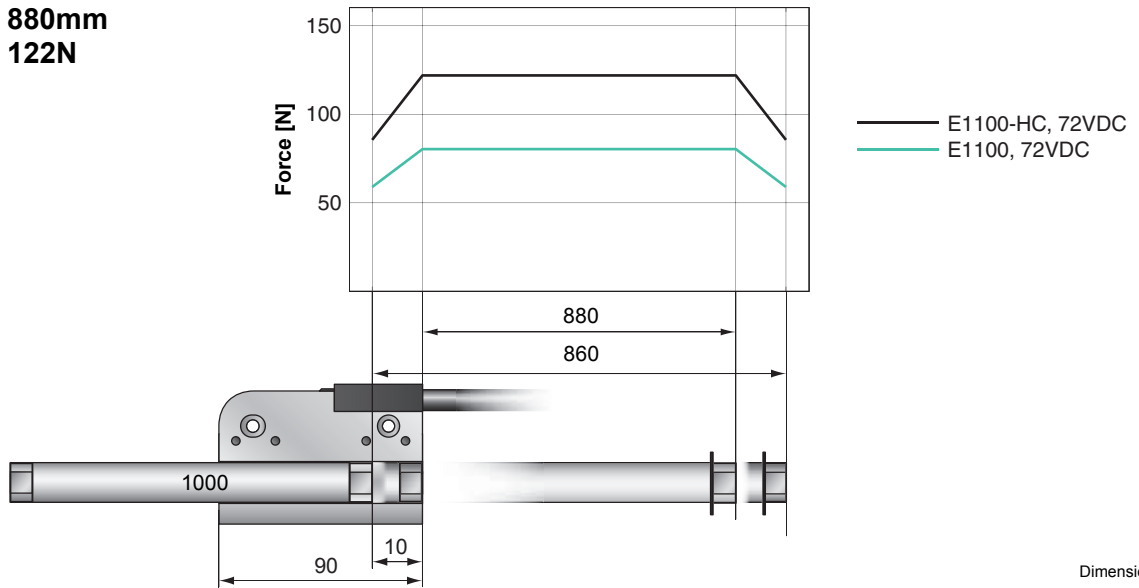

Dimensions in mm

Motor Specification

Stator		Standard Winding	
		High Performance	High Performance Heavy Duty
Standard Stroke SS	mm (in)	860 (33.86)	
Extended Stroke ES	mm (in)	880 (34.65)	
Max. Force	N (lbf)	122 (28.6)	
Cont. Force	N (lbf)	20 (4.50)	
Cont. Force with fan	N (lbf)	35 (7.87)	
Max. Velocity	m/s (in/s)	5.0	
Max. Current	A	12.0	
Cont. Current	A	3.0	
Cont. Current with fan	A	5.0	
Force Constant	N/A (lbf/A)	10.2 (2.30)	
Border Force	%	67	
Linearity	%	±0.1	
Slider Length	mm (in)	1000 (39.37)	
Slider Mass	g (lb)	2270 (5.00)	

Ordering Information



PS01-37Sx60-HP-N	Stator HP with N-connector IP50	0150-1295
------------------	---------------------------------	-----------



PL01-20x1000/940-HP	High Performance Slider	0150-1514
PL02-20x1000/940-HP	High Performance Slider, Heavy Duty	on request

Max. Stroke: 1080mm
Max. Force: 122N

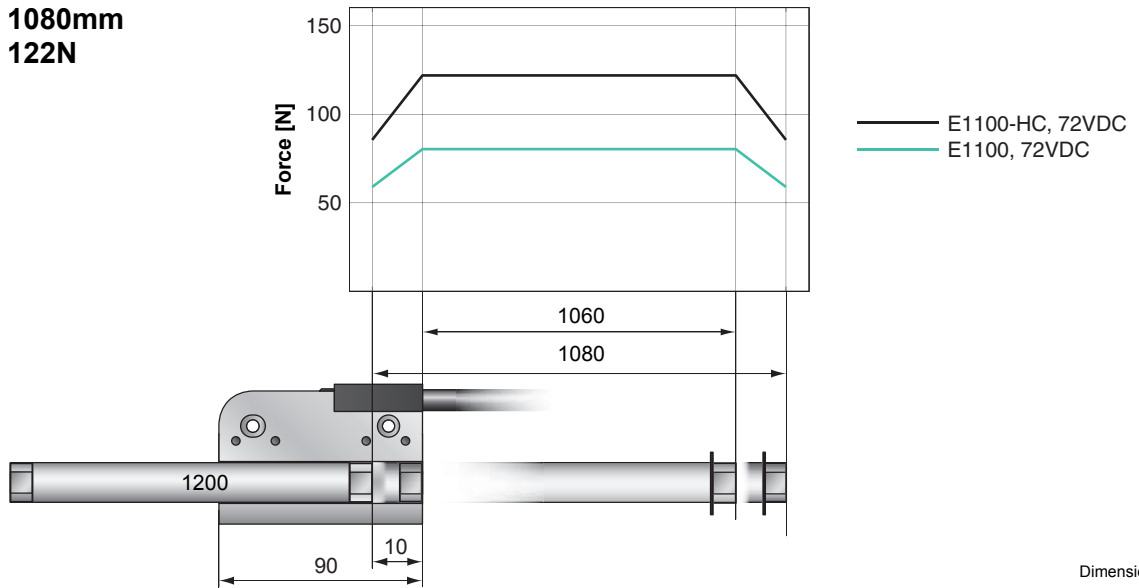

Dimensions in mm

Motor Specification

Stator		Standard Winding
Slider		High Performance High Performance Heavy Duty
Standard Stroke SS	mm (in)	1060 (41.73)
Extended Stroke ES	mm (in)	1080 (42.52)
Max. Force	N (lbf)	122 (28.6)
Cont. Force	N (lbf)	20 (4.50)
Cont. Force with fan	N (lbf)	35 (7.87)
Max. Velocity	m/s (in/s)	5.0
Max. Current	A	12.0
Cont. Current	A	3.0
Cont. Current with fan	A	5.0
Force Constant	N/A (lbf/A)	10.2 (2.30)
Border Force	%	67
Linearity	%	±0.1
Slider Length	mm (in)	1200 (47.24)
Slider Mass	g (lb)	2740 (6.04)

Ordering Information



PS01-37Sx60-HP-N	Stator HP with N-connector IP50	0150-1295
------------------	---------------------------------	-----------



PL01-20x1200/1140-HP	High Performance Slider	0150-1515
PL02-20x1200/1140-HP	High Performance Slider, Heavy Duty	on request

Max. Stroke: 1280mm
Max. Force: 122N

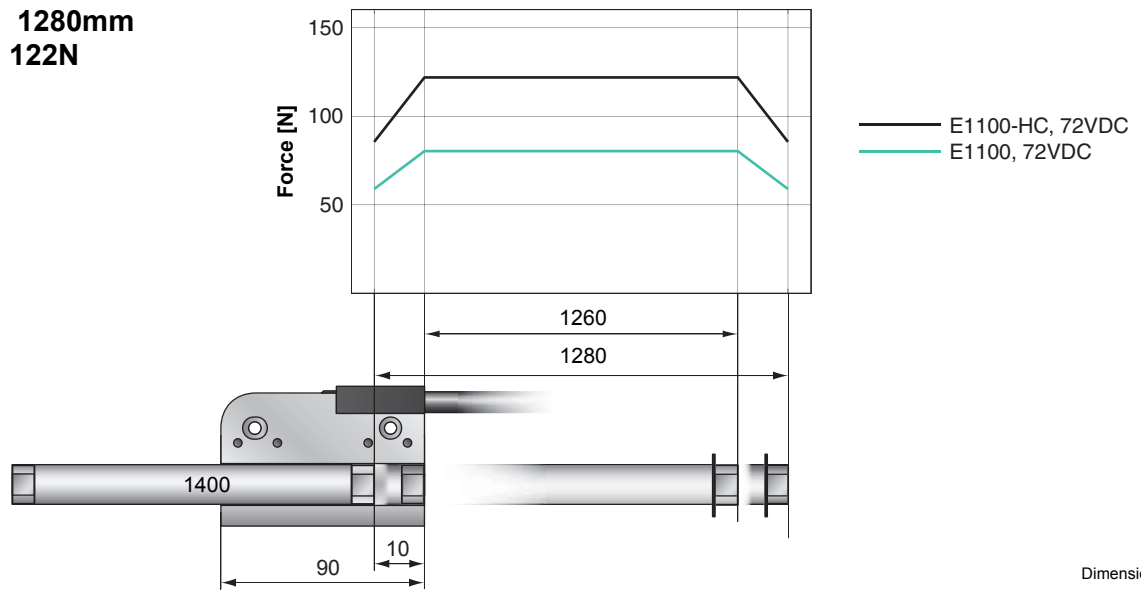

Dimensions in mm

Motor Specification

Stator		Standard Winding
Slider		High Performance High Performance Heavy Duty
Standard Stroke SS	mm (in)	1260 (49.61)
Extended Stroke ES	mm (in)	1280 (50.39)
Max. Force	N (lbf)	122 (28.6)
Cont. Force	N (lbf)	20 (4.50)
Cont. Force with fan	N (lbf)	35 (7.87)
Max. Velocity	m/s (in/s)	5.0
Max. Current	A	12.0
Cont. Current	A	3.0
Cont. Current with fan	A	5.0
Force Constant	N/A (lbf/A)	10.2 (2.30)
Border Force	%	67
Linearity	%	±0.1
Slider Length	mm (in)	1400 (55.12)
Slider Mass	g (lb)	3170 (6.99)

Ordering Information



PS01-37Sx60-HP-N	Stator HP with N-connector IP50	0150-1295
------------------	---------------------------------	-----------



PL01-20x1400/1340-HP	High Performance Slider	0150-1516
PL02-20x1400/1340-HP	High Performance Slider, Heavy Duty	on request

Max. Stroke: 1480mm
 Max. Force: 122N

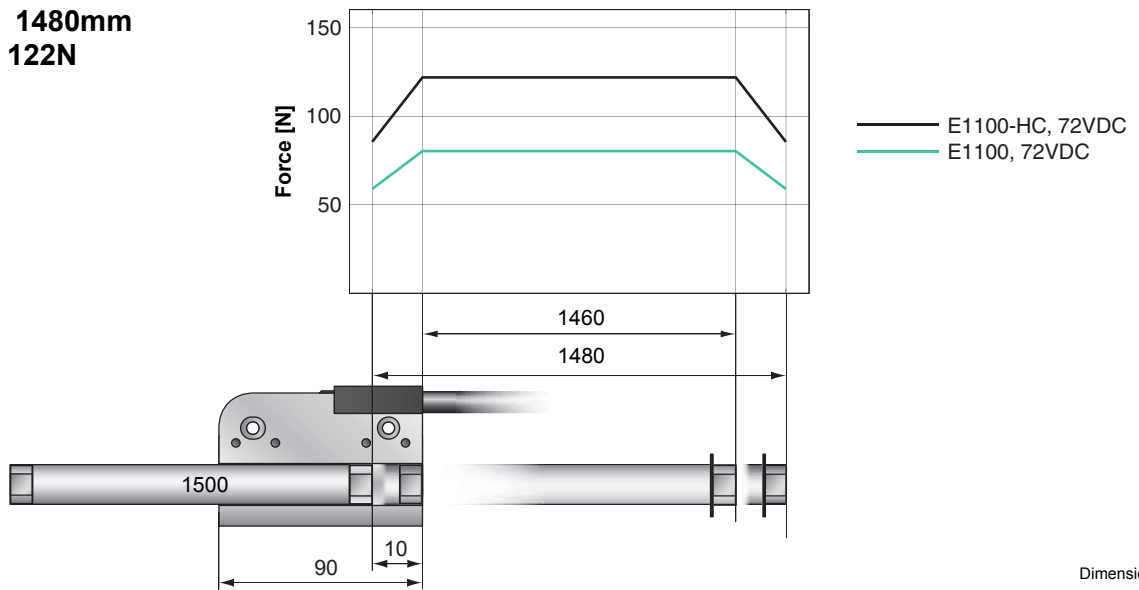

Dimensions in mm

Motor Specification

Stator		Standard Winding
Slider		High Performance High Performance Heavy Duty
Standard Stroke SS	mm (in)	1460 (57.48)
Extended Stroke ES	mm (in)	1480 (58.27)
Max. Force	N (lbf)	122 (28.6)
Cont. Force	N (lbf)	20 (4.50)
Cont. Force with fan	N (lbf)	35 (7.87)
Max. Velocity	m/s (in/s)	5.0
Max. Current	A	12.0
Cont. Current	A	3.0
Cont. Current with fan	A	5.0
Force Constant	N/A (lbf/A)	10.2 (2.30)
Border Force	%	67
Linearity	%	±0.1
Slider Length	mm (in)	1600 (62.99)
Slider Mass	g (lb)	3640 (8.02)

Ordering Information



PS01-37Sx60-HP-N	Stator HP with N-connector IP50	0150-1295
------------------	---------------------------------	-----------



PL01-20x1600/1540-HP	High Performance Slider	0150-1517
PL02-20x1600/1540-HP	High Performance Slider, Heavy Duty	on request



N-Connector

Motor Connector Wiring

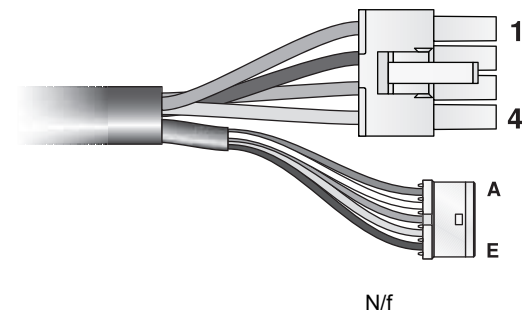

Power Connector

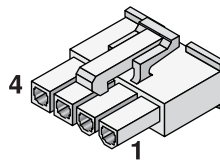

Pin 1	red	Phase 1+
Pin 2	pink	Phase 1-
Pin 3	blue	Phase 2+
Pin 4	grey	Phase 2-

Signal Connector

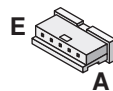

Pin A	white	+5V
Pin B	inner Shield	Ground
Pin C	yellow	Sensor Sin
Pin D	green	Sensor Cos
Pin E	black	Temp sensor
case	outerShield	shield

Ordering Information

High Flex Motor Cable directly to the Drive

Item	Description	Part Number
KS05-W/N-2	High Flex cable W/N, 2m	0150-2296
KS05-W/N-4	High Flex cable W/N, 4m	0150-2297
KS05-W/N-6	High Flex cable W/N, 6m	0150-2298
KS05-W/N-8	High Flex cable W/N, 8m	0150-2299
KS05-W/N-	High Flex cable W/N. Custom Length	0150-3412

Connectors & Cable

KS05-04/05	High Flex cable per m	0150-1938
KR05-W/R-	Robot cable W/R, per m	0150-3406
MC01-N/f	N/f connector	0150-3407
MC01-N/f-as	N/f connector, assembled	0150-3408

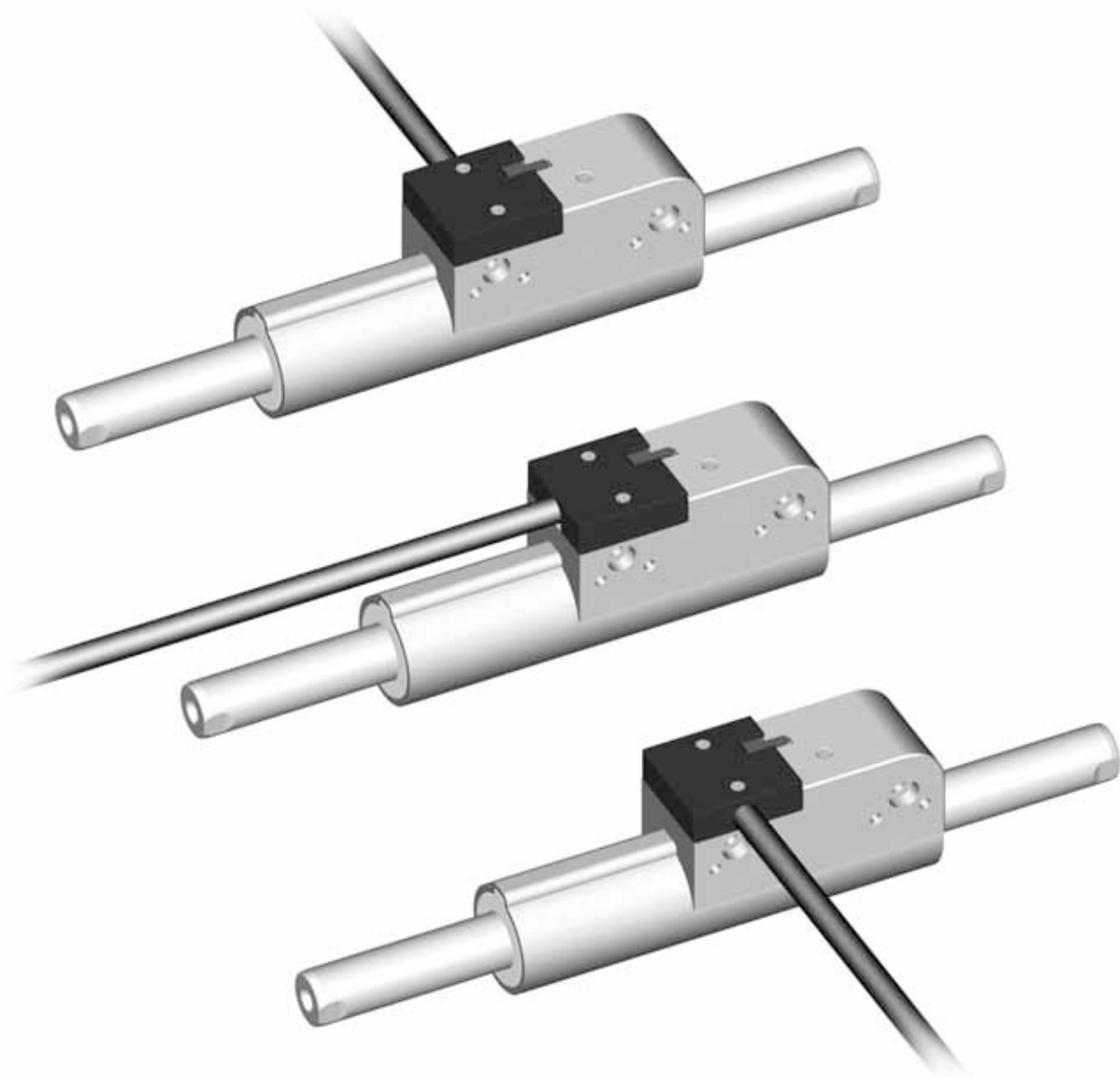

Series P01-37Sx120F-HP 260

P01-37Sx120F/40x120-HP 263

P01-37Sx120F/100x180-HP 264

P01-37Sx120F/160x240-HP 265

P01-37Sx120F/200x280-HP 266

P01-37Sx120F/300x380-HP 267

P01-37Sx120F/400x480-HP 268

P01-37Sx120F/500x580-HP 269

P01-37Sx120F/600x680-HP 270

P01-37Sx120F/700x780-HP 271

P01-37Sx120F/800x880-HP 272

P01-37Sx120F/1000x1080-HP 273

P01-37Sx120F/1200x1280-HP 274

P01-37Sx120F/1400x1480-HP 275

Motor Cable 276

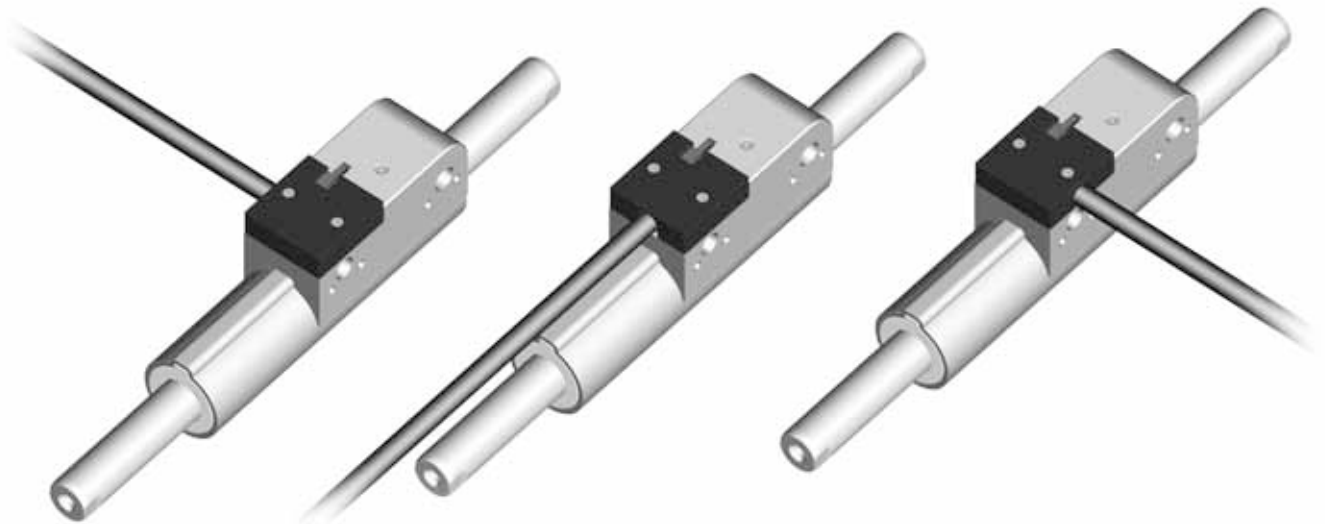

Motor Specification

		P01-37Sx120F-HP/...
Maximum Stroke	mm (in)	1480 (58.27)
Maximum Force	N (lbf)	255 (57.3)
Maximum Velocity	m/s (in/s)	3.2 (126)
Max. Current	A	15
Cont. Current	A	4
Phase Resist. 25 °C	Ohm	2.3
Phase Resist. 80 °C	Ohm	3.2
Phase Inductance	mH	1.6
Thermal Resistance	°K/W	3.2
Thermal Time Const.	sec	4500
Stator Diameter	mm (in)	37 (1.46) / 38 (1.50)
Stator Length	mm (in)	150 (5.91)
Stator Mass	g (lb)	792
Slider Diameter	mm (in)	20 (0.79)
Position Resolution	mm (in)	0.01
Position Repeatability	mm (in)	±0.05 (±0.0020)
Position Resolution ES	mm (in)	0.001
Repeatability with EPS	mm (in)	±0.01 (±0.0004)

Accessories



Servo Drive:
E1100



E1200



B1100-HC

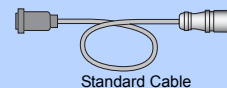

Standard Cable

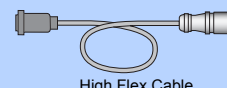

High Flex Cable



Robotic Cable

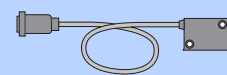

Optional Linear Encoder

Stator

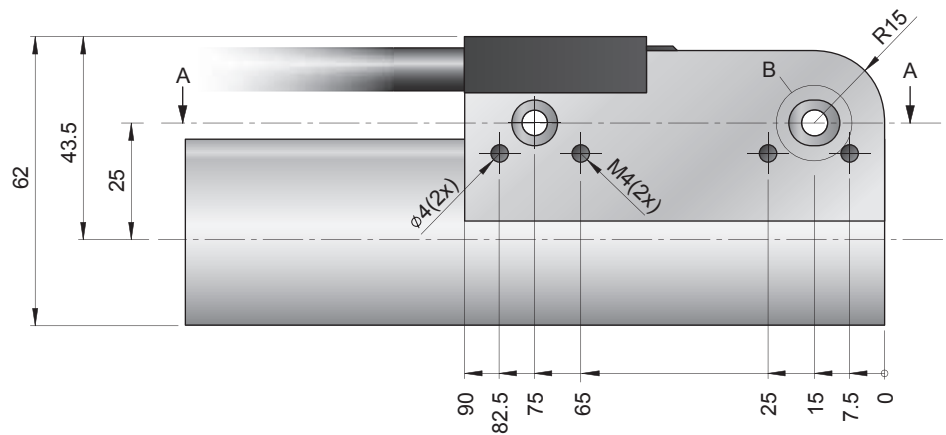
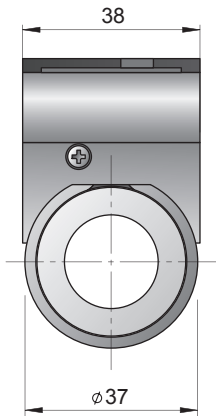

Detail B

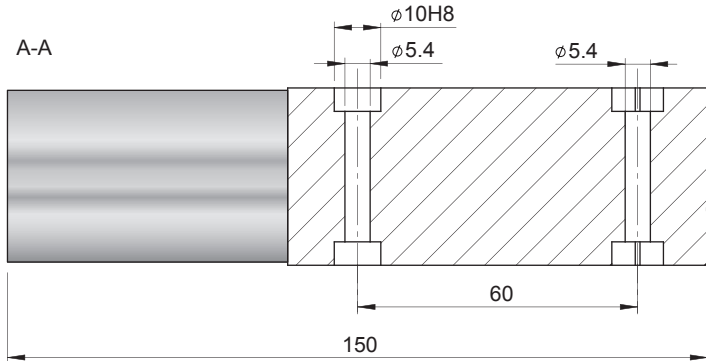
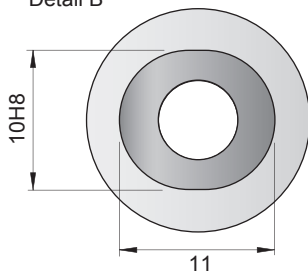

N-Connector

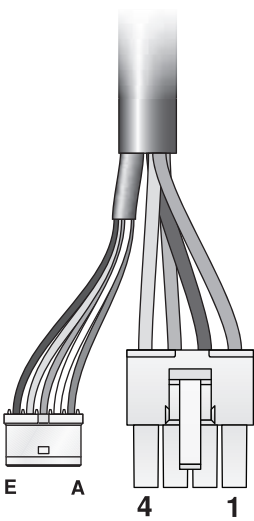

Motor Connector Wiring

Pin 1	red	Phase 1+
Pin 2	pink	Phase 1-
Pin 3	blue	Phase 2+
Pin 4	grey	Phase 2-

Pin A	white	+5V
Pin B	inner Shield	GND
Pin C	yellow	Sensor Sin
Pin D	green	Sensor Cos
Pin E	black	Temp sensor
case	outer Shield	shield

Stators are shipped with three covers for left/right/straight cable outlet

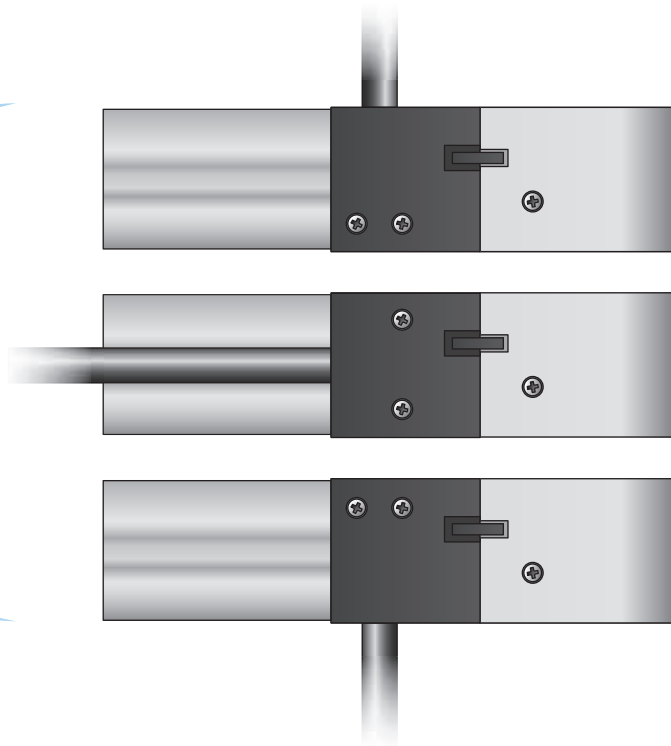

Ordering Information

Item	Description	Part Number
PS01-37Sx120F-HP-N	Stator HP with N-connector IP50	0150-1296

Sliders

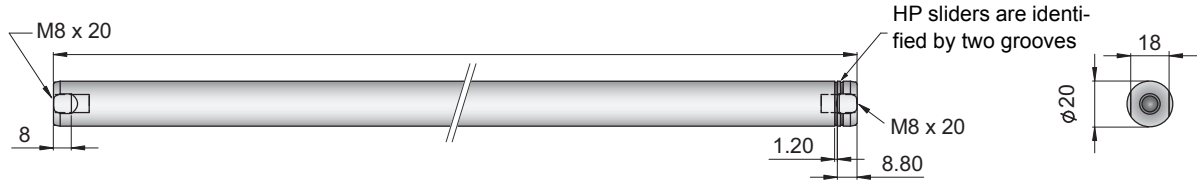

High Performance Slider		Length [mm]	Stroke [mm]	Part Number
PL01-20x240/180-HP	slider "High Performance"	240	40x120	0150-1505
PL01-20x300/240-HP	slider "High Performance"	300	100x180	0150-1506
PL01-20x360/300-HP	slider "High Performance"	360	160x240	0150-1507
PL01-20x400/340-HP	slider "High Performance"	400	200x280	0150-1508
PL01-20x500/440-HP	slider "High Performance"	500	300x380	0150-1509
PL01-20x600/540-HP	slider "High Performance"	600	400x480	0150-1510
PL01-20x700/640-HP	slider "High Performance"	700	500x580	0150-1511
PL01-20x800/740-HP	slider "High Performance"	800	600x680	0150-1512
PL01-20x900/840-HP	slider "High Performance"	900	700x780	0150-1513
PL01-20x1000/940-HP	slider "High Performance"	1000	800x880	0150-1514
PL01-20x1200/1140-HP	slider "High Performance"	1200	1000x1080	0150-1515
PL01-20x1400/1340-HP	slider "High Performance"	1400	1200x1280	0150-1516
PL01-20x1600/1540-HP	slider "High Performance"	1600	1400x1480	0150-1517

Max. Stroke: 120mm
Max. Force: 255N

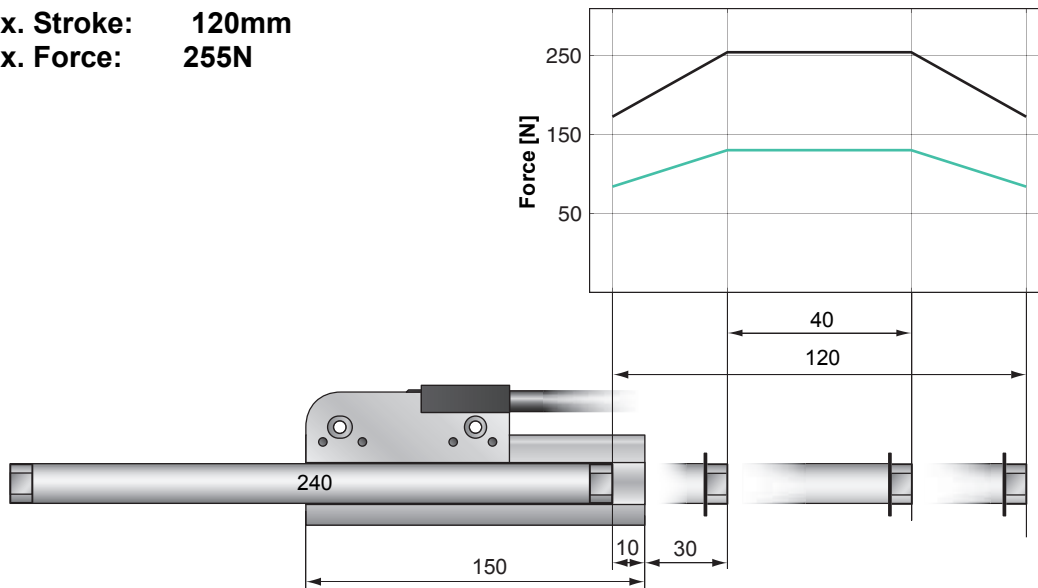

Dimensions in mm

Motor Specification

Stator		Standard Winding
Slider		High Performance High Performance Heavy Duty
Standard Stroke SS	mm (in)	40 (1.57)
Extended Stroke ES	mm (in)	120 (4.72)
Max. Force	N (lbf)	255 (57.3)
Cont. Force	N (lbf)	35 (7.87)
Cont. Force with fan	N (lbf)	65 (14.6)
Max. Velocity	m/s (in/s)	3.9 (154)
Max. Current	A _{pk}	15
Cont. Current	A _{pk}	2.35
Cont. Current with fan	A _{pk}	4.10
Force Constant	N/A (lbf/A)	17 (3.83)
Border Force	%	67
Linearity	%	±0.1
Slider Length	mm (in)	240 (8.45)
Slider Mass	g (lb)	510 (1.12)

Ordering Information

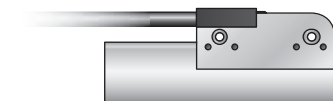

PS01-37Sx120F-HP-N	Stator HP with N-connector IP50	0150-1296
--------------------	---------------------------------	-----------



PL01-20x240/180-HP	High Performance Slider	0150-1505
PL02-20x240/180-HP	High Performance Slider, Heavy Duty	on request

Max. Stroke: 180mm
Max. Force: 255N

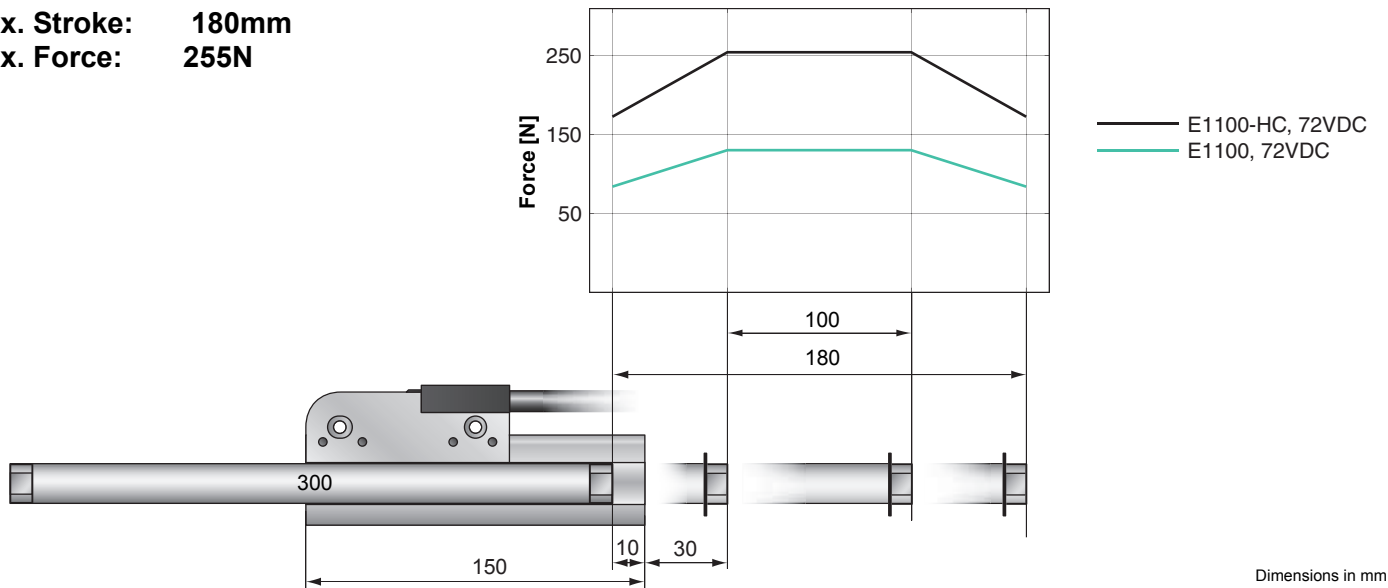

Motor Specification

Stator		Standard Winding
Slider		High Performance High Performance Heavy Duty
Standard Stroke SS	mm (in)	100 (3.94)
Extended Stroke ES	mm (in)	180 (7.09)
Max. Force	N (lbf)	255 (57.3)
Cont. Force	N (lbf)	35 (7.87)
Cont. Force with fan	N (lbf)	65 (14.6)
Max. Velocity	m/s (in/s)	3.9 (154)
Max. Current	A _{pk}	15
Cont. Current	A _{pk}	2.35
Cont. Current with fan	A _{pk}	4.10
Force Constant	N/A (lbf/A)	17 (3.83)
Border Force	%	67
Linearity	%	±0.1
Slider Length	mm (in)	300 (11.81)
Slider Mass	g (lb)	650 (1.43)

Ordering Information

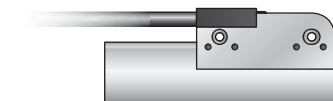

PS01-37Sx120F-HP-N	Stator HP with N-connector IP50	0150-1296
--------------------	---------------------------------	-----------



PL01-20x300/240-HP	High Performance Slider	0150-1506
PL02-20x300/240-HP	High Performance Slider, Heavy Duty	on request

Max. Stroke: 240mm
Max. Force: 255N

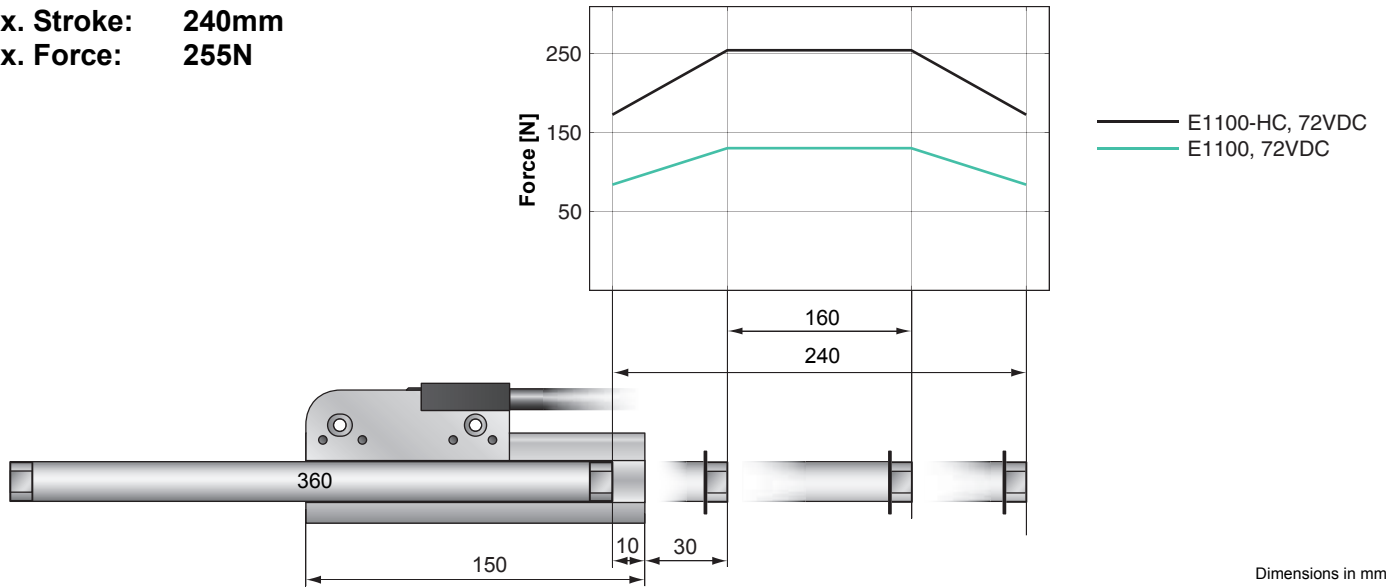

Motor Specification

Stator		Standard Winding
Slider		High Performance High Performance Heavy Duty
Standard Stroke SS	mm (in)	160 (6.30)
Extended Stroke ES	mm (in)	240 (9.45)
Max. Force	N (lbf)	255 (57.3)
Cont. Force	N (lbf)	35 (7.87)
Cont. Force with fan	N (lbf)	65 (14.6)
Max. Velocity	m/s (in/s)	3.9 (154)
Max. Current	A _{pk}	15
Cont. Current	A _{pk}	2.35
Cont. Current with fan	A _{pk}	4.10
Force Constant	N/A (lbf/A)	17 (3.83)
Border Force	%	67
Linearity	%	±0.1
Slider Length	mm (in)	360 (14.17)
Slider Mass	g (lb)	800 (1.76)

Ordering Information



PS01-37Sx120F-HP-N	Stator HP with N-connector IP50	0150-1296
--------------------	---------------------------------	-----------



PL01-20x360/300-HP	High Performance Slider	0150-1507
PL02-20x360/300-HP	High Performance Slider, Heavy Duty	on request

Max. Stroke: 280mm
Max. Force: 255N

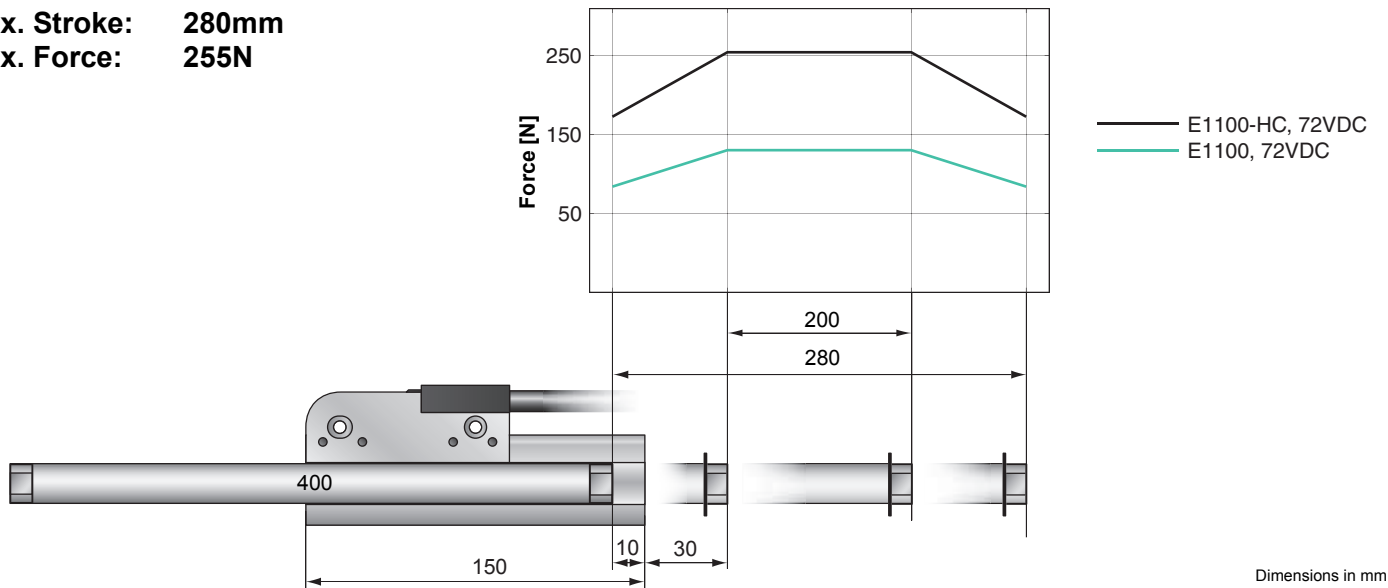

Motor Specification

Stator		Standard Winding
Slider		High Performance High Performance Heavy Duty
Standard Stroke SS	mm (in)	200 (7.87)
Extended Stroke ES	mm (in)	280 (11.02)
Max. Force	N (lbf)	255 (57.3)
Cont. Force	N (lbf)	35 (7.87)
Cont. Force with fan	N (lbf)	65 (14.6)
Max. Velocity	m/s (in/s)	3.9 (154)
Max. Current	A _{pk}	15
Cont. Current	A _{pk}	2.35
Cont. Current with fan	A _{pk}	4.10
Force Constant	N/A (lbf/A)	17 (3.83)
Border Force	%	67
Linearity	%	±0.1
Slider Length	mm (in)	400 (15.75)
Slider Mass	g (lb)	880 (1.94)

Ordering Information

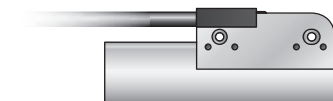

PS01-37Sx120F-HP-N	Stator HP with N-connector IP50	0150-1296
--------------------	---------------------------------	-----------



PL01-20x400/340-HP	High Performance Slider	0150-1508
PL02-20x400/340-HP	High Performance Slider, Heavy Duty	on request

Max. Stroke: 380mm
Max. Force: 255N

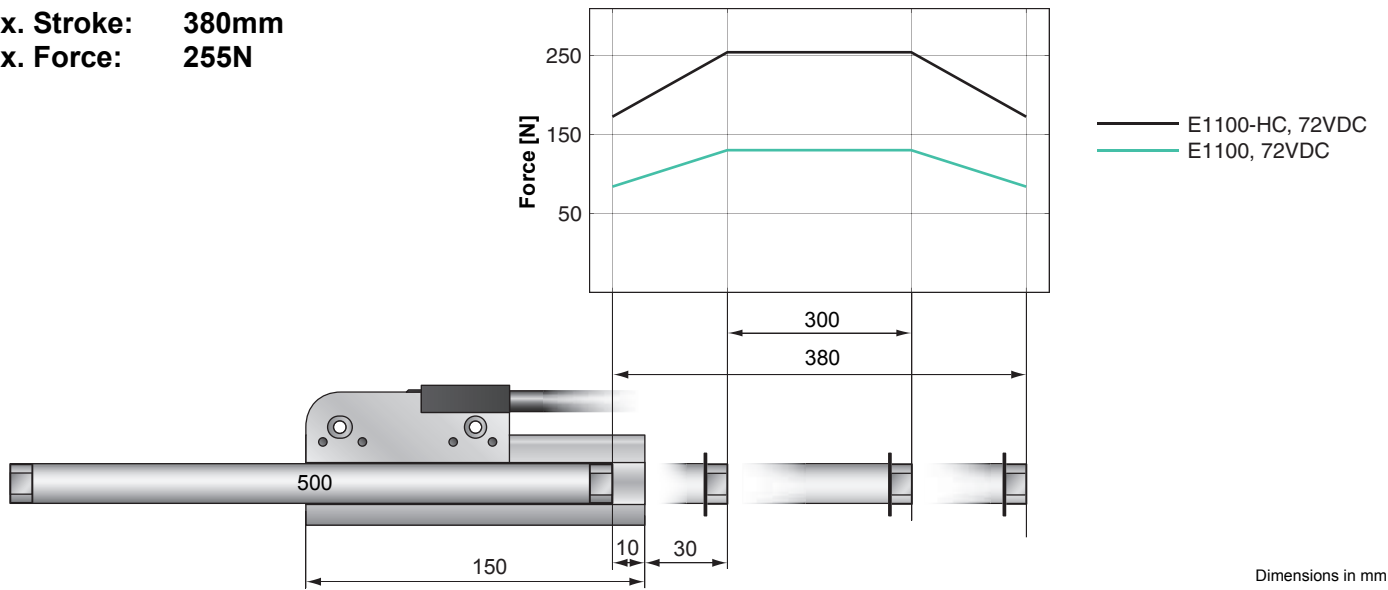

Motor Specification

Stator		Standard Winding
Slider		High Performance High Performance Heavy Duty
Standard Stroke SS	mm (in)	300 (11.81)
Extended Stroke ES	mm (in)	380 (14.96)
Max. Force	N (lbf)	255 (57.3)
Cont. Force	N (lbf)	35 (7.87)
Cont. Force with fan	N (lbf)	65 (14.6)
Max. Velocity	m/s (in/s)	3.9 (154)
Max. Current	A _{pk}	15
Cont. Current	A _{pk}	2.35
Cont. Current with fan	A _{pk}	4.10
Force Constant	N/A (lbf/A)	17 (3.83)
Border Force	%	67
Linearity	%	±0.1
Slider Length	mm (in)	500 (19.69)
Slider Mass	g (lb)	1110 (2.45)

Ordering Information

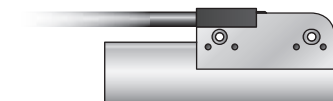

PS01-37Sx120F-HP-N	Stator HP with N-connector IP50	0150-1296
--------------------	---------------------------------	-----------



PL01-20x500/440-HP	High Performance Slider	0150-1509
PL02-20x500/440-HP	High Performance Slider, Heavy Duty	on request

Max. Stroke: 480mm
Max. Force: 255N

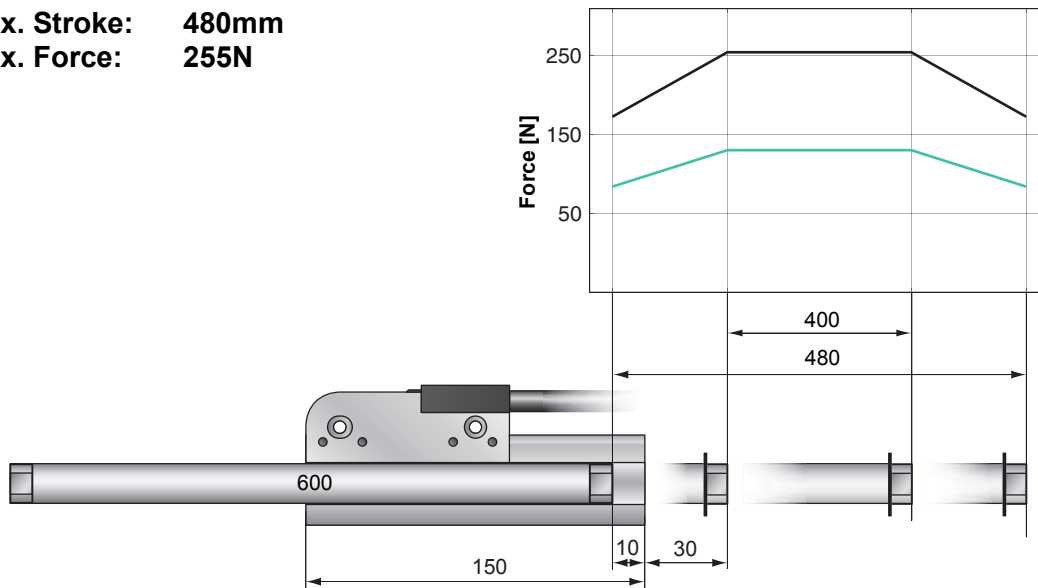

— E1100-HC, 72VDC
 — E1100, 72VDC

Dimensions in mm

Motor Specification

Stator		Standard Winding
Slider		High Performance High Performance Heavy Duty
Standard Stroke SS	mm (in)	400 (15.75)
Extended Stroke ES	mm (in)	480 (18.90)
Max. Force	N (lbf)	255 (57.3)
Cont. Force	N (lbf)	35 (7.87)
Cont. Force with fan	N (lbf)	65 (14.6)
Max. Velocity	m/s (in/s)	3.9 (154)
Max. Current	A _{pk}	15
Cont. Current	A _{pk}	2.35
Cont. Current with fan	A _{pk}	4.10
Force Constant	N/A (lbf/A)	17 (3.83)
Border Force	%	67
Linearity	%	±0.1
Slider Length	mm (in)	600 (23.62)
Slider Mass	g (lb)	1350 (2.98)

Ordering Information

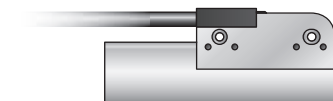

PS01-37Sx120F-HP-N	Stator HP with N-connector IP50	0150-1296
--------------------	---------------------------------	-----------



PL01-20x600/540-HP	High Performance Slider	0150-1510
PL02-20x600/540-HP	High Performance Slider, Heavy Duty	on request

Max. Stroke: 580mm
Max. Force: 255N

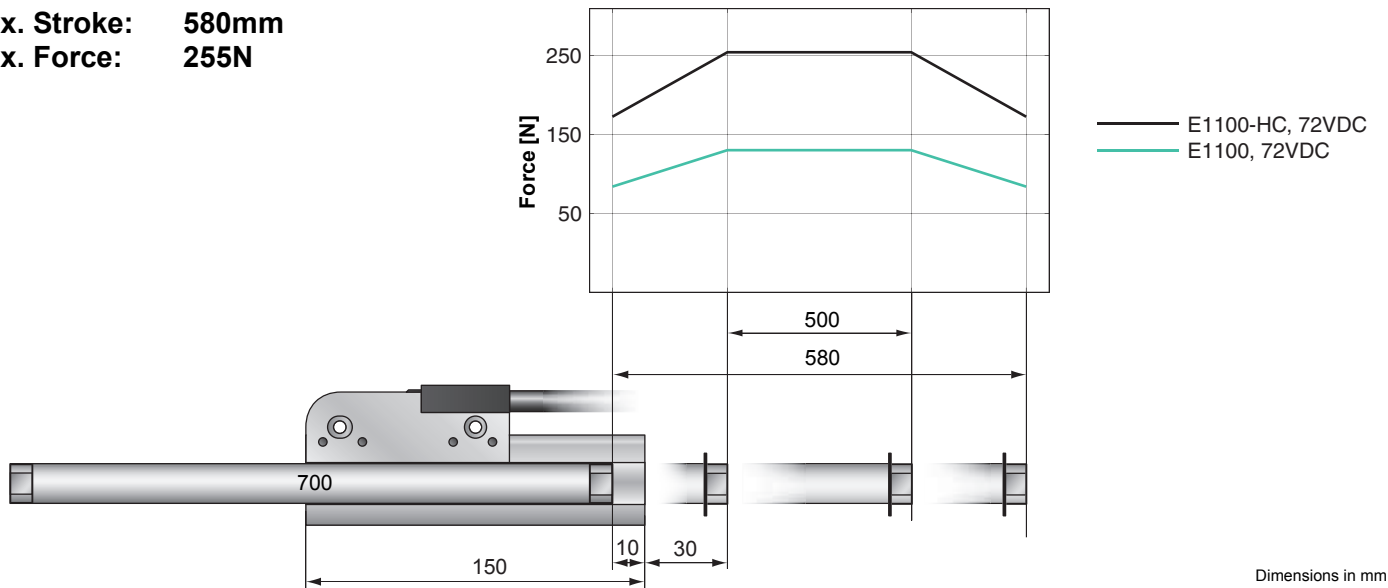

Motor Specification

Stator		Standard Winding
Slider		High Performance High Performance Heavy Duty
Standard Stroke SS	mm (in)	500 (19.69)
Extended Stroke ES	mm (in)	580 (22.83)
Max. Force	N (lbf)	255 (57.3)
Cont. Force	N (lbf)	35 (7.87)
Cont. Force with fan	N (lbf)	65 (14.6)
Max. Velocity	m/s (in/s)	3.9 (154)
Max. Current	A _{pk}	15
Cont. Current	A _{pk}	2.35
Cont. Current with fan	A _{pk}	4.10
Force Constant	N/A (lbf/A)	17 (3.83)
Border Force	%	67
Linearity	%	±0.1
Slider Length	mm (in)	700 (27.56)
Slider Mass	g (lb)	1580 (3.48)

Ordering Information

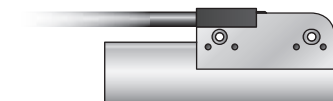

PS01-37Sx120F-HP-N	Stator HP with N-connector IP50	0150-1296
--------------------	---------------------------------	-----------



PL01-20x700/640-HP	High Performance Slider	0150-1511
PL02-20x700/640-HP	High Performance Slider, Heavy Duty	on request

Max. Stroke: 680mm
Max. Force: 255N

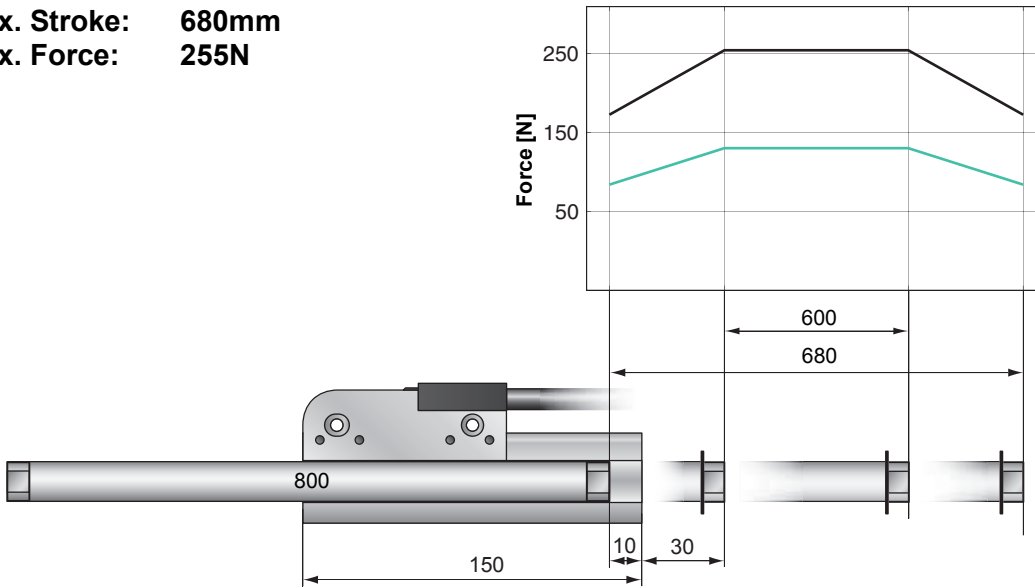

Dimensions in mm

Motor Specification

Stator		Standard Winding
Slider		High Performance High Performance Heavy Duty
Standard Stroke SS	mm (in)	600 (23.62)
Extended Stroke ES	mm (in)	680 (26.77)
Max. Force	N (lbf)	255 (57.3)
Cont. Force	N (lbf)	35 (7.87)
Cont. Force with fan	N (lbf)	65 (14.6)
Max. Velocity	m/s (in/s)	3.9 (154)
Max. Current	A _{pk}	15
Cont. Current	A _{pk}	2.35
Cont. Current with fan	A _{pk}	4.10
Force Constant	N/A (lbf/A)	17 (3.83)
Border Force	%	67
Linearity	%	±0.1
Slider Length	mm (in)	800 (31.50)
Slider Mass	g (lb)	1810 (3.99)

Ordering Information



PS01-37Sx120F-HP-N	Stator HP with N-connector IP50	0150-1296
--------------------	---------------------------------	-----------



PL01-20x800/740-HP	High Performance Slider	0150-1512
PL02-20x800/740-HP	High Performance Slider, Heavy Duty	on request

Max. Stroke: 780mm
Max. Force: 255N

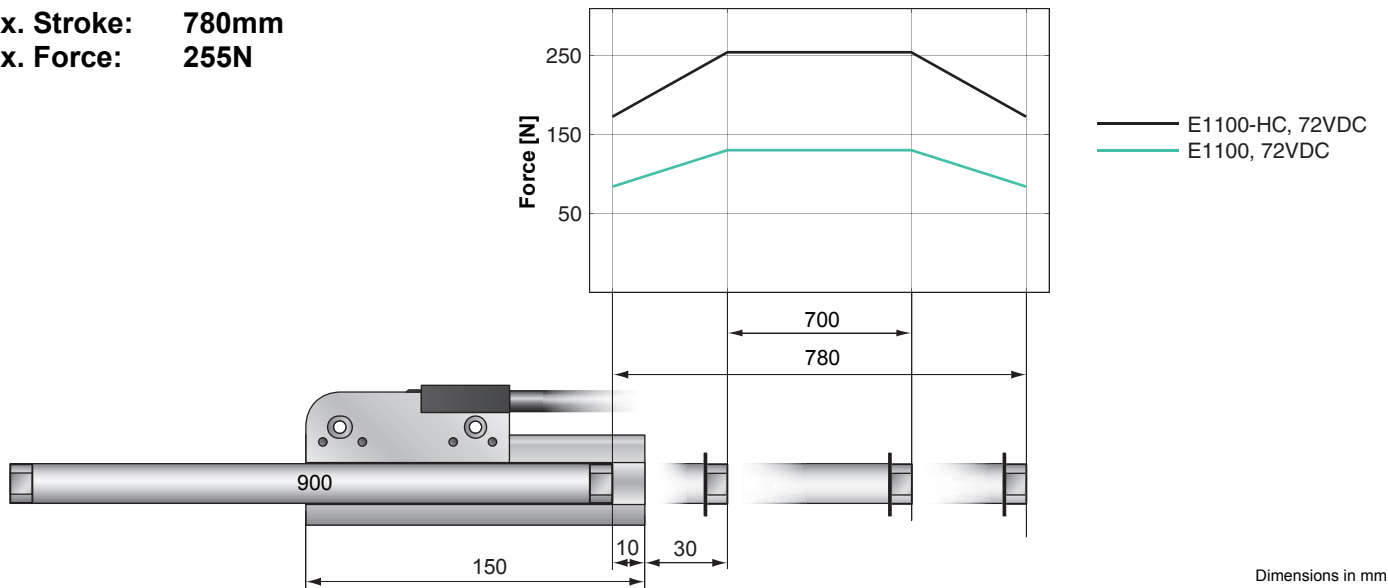

Dimensions in mm

Motor Specification

Stator		Standard Winding
Slider		High Performance High Performance Heavy Duty
Standard Stroke SS	mm (in)	700 (27.56)
Extended Stroke ES	mm (in)	780 (30.71)
Max. Force	N (lbf)	255 (57.3)
Cont. Force	N (lbf)	35 (7.87)
Cont. Force with fan	N (lbf)	65 (14.6)
Max. Velocity	m/s (in/s)	3.9 (154)
Max. Current	A _{pk}	15
Cont. Current	A _{pk}	2.35
Cont. Current with fan	A _{pk}	4.10
Force Constant	N/A (lbf/A)	17 (3.83)
Border Force	%	67
Linearity	%	±0.1
Slider Length	mm (in)	900 (35.43)
Slider Mass	g (lb)	2040 (4.50)

Ordering Information

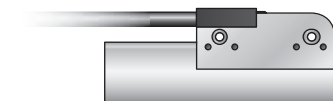

PS01-37Sx120F-HP-N	Stator HP with N-connector IP50	0150-1296
--------------------	---------------------------------	-----------



PL01-20x900/840-HP	High Performance Slider	0150-1513
PL01-20x900/840-HP	High Performance Slider, Heavy Duty	on request

Max. Stroke: 880mm
Max. Force: 255N

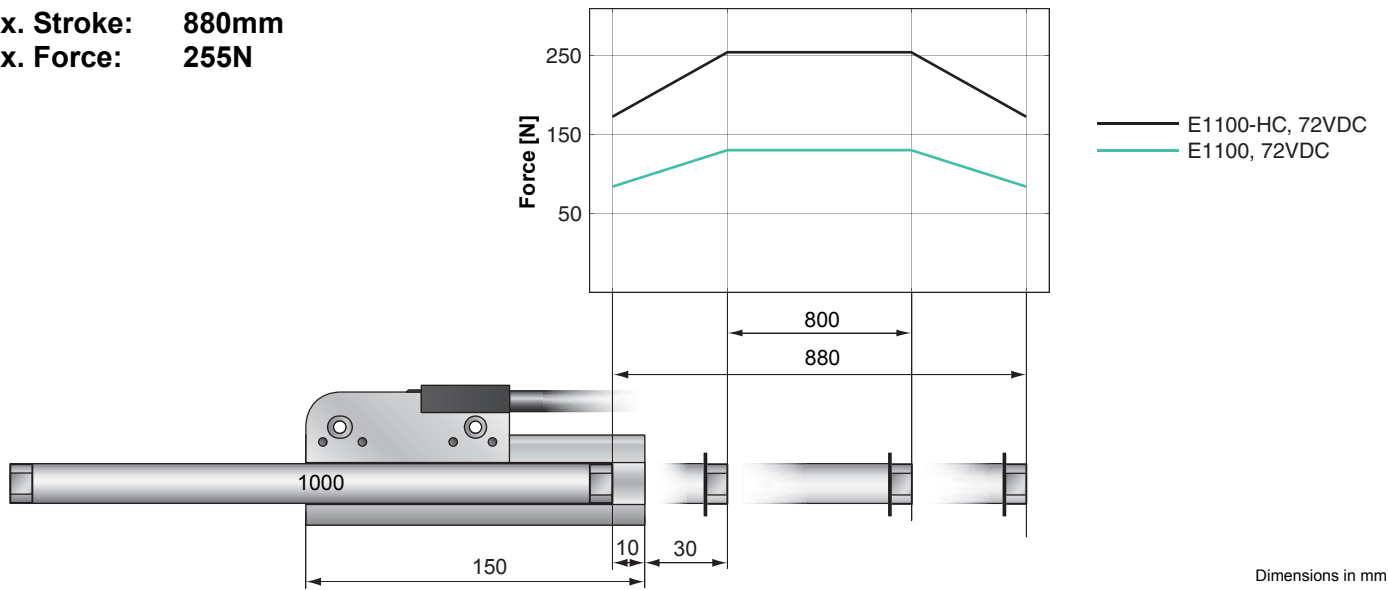

Motor Specification

Stator		Standard Winding
Slider		High Performance High Performance Heavy Duty
Standard Stroke SS	mm (in)	800 (31.50)
Extended Stroke ES	mm (in)	880 (34.65)
Max. Force	N (lbf)	255 (57.3)
Cont. Force	N (lbf)	35 (7.87)
Cont. Force with fan	N (lbf)	65 (14.6)
Max. Velocity	m/s (in/s)	3.9 (154)
Max. Current	A _{pk}	15
Cont. Current	A _{pk}	2.35
Cont. Current with fan	A _{pk}	4.10
Force Constant	N/A (lbf/A)	17 (3.83)
Border Force	%	67
Linearity	%	±0.1
Slider Length	mm (in)	1000 (39.37)
Slider Mass	g (lb)	2270 (5.00)

Ordering Information

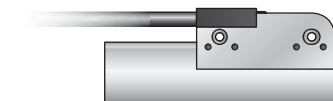

PS01-37Sx120F-HP-N	Stator HP with N-connector IP50	0150-1296
--------------------	---------------------------------	-----------



PL01-20x1000/940-HP	High Performance Slider	0150-1514
PL02-20x1000/940-HP	High Performance Slider, Heavy Duty	on request

Max. Stroke: 1080mm
Max. Force: 255N

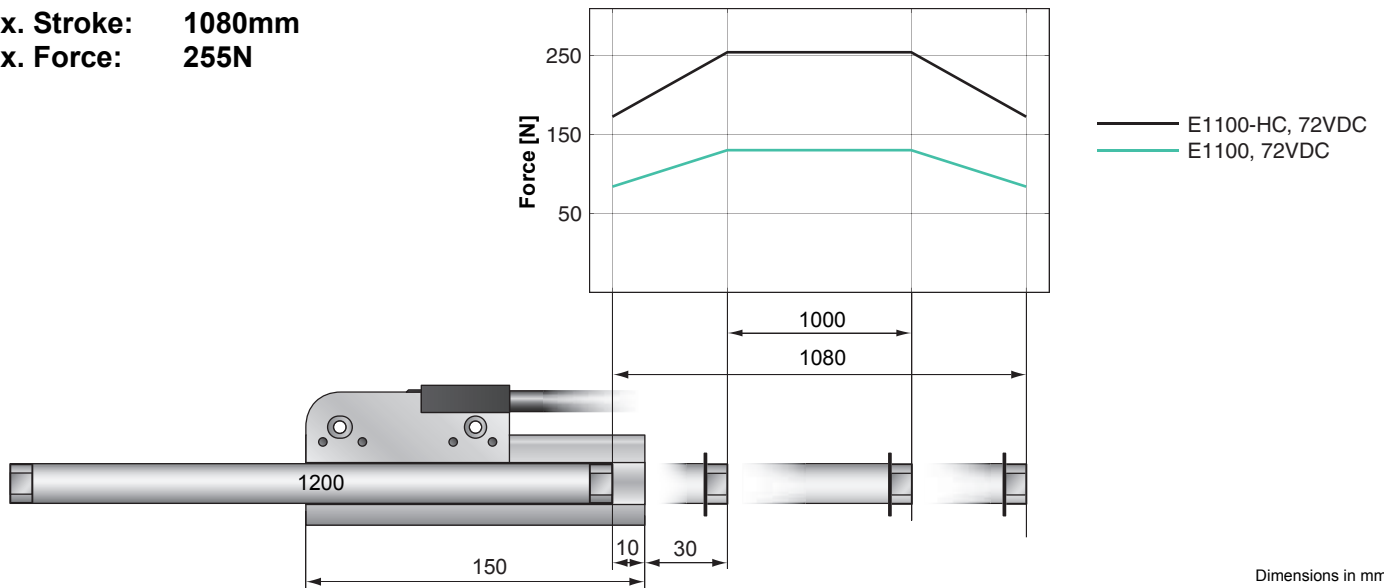

Motor Specification

Stator		Standard Winding
Slider		High Performance High Performance Heavy Duty
Standard Stroke SS	mm (in)	1000 (39.37)
Extended Stroke ES	mm (in)	1080 (42.52)
Max. Force	N (lbf)	255 (57.3)
Cont. Force	N (lbf)	35 (7.87)
Cont. Force with fan	N (lbf)	65 (14.6)
Max. Velocity	m/s (in/s)	3.9 (154)
Max. Current	A _{pk}	15
Cont. Current	A _{pk}	2.35
Cont. Current with fan	A _{pk}	4.10
Force Constant	N/A (lbf/A)	17 (3.83)
Border Force	%	67
Linearity	%	±0.1
Slider Length	mm (in)	1200 (47.24)
Slider Mass	g (lb)	2740 (6.04)

Ordering Information

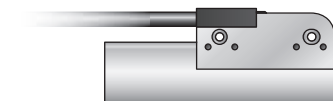

PS01-37Sx120F-HP-N	Stator HP with N-connector IP50	0150-1296
--------------------	---------------------------------	-----------



PL01-20x1200/1140-HP	High Performance Slider	0150-1515
PL02-20x1200/1140-HP	High Performance Slider, Heavy Duty	on request

Max. Stroke: 1280mm
Max. Force: 255N

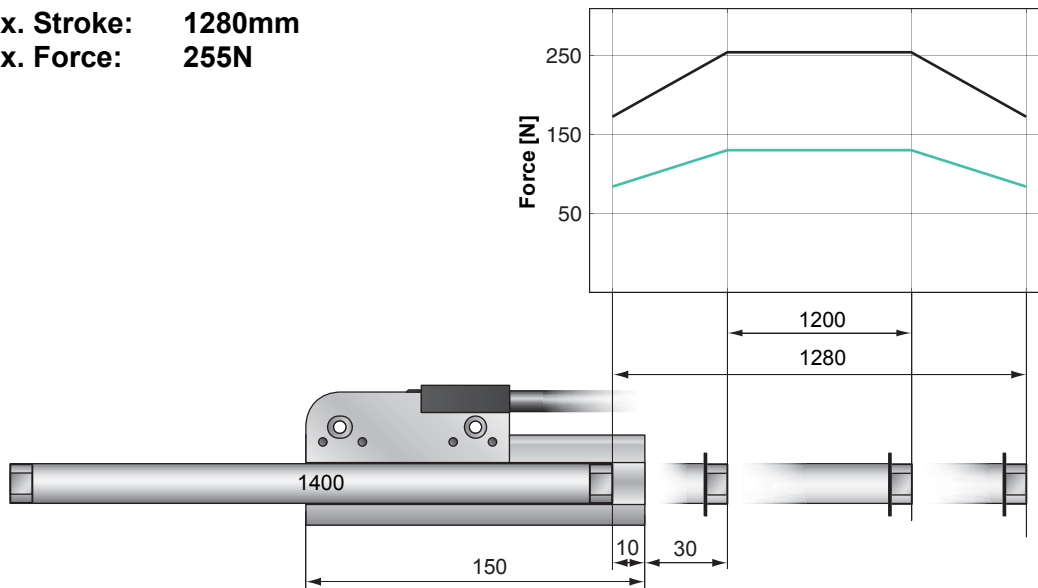

— E1100-HC, 72VDC
 — E1100, 72VDC

Dimensions in mm

Motor Specification

Stator		Standard Winding
Slider		High Performance High Performance Heavy Duty
Standard Stroke SS	mm (in)	1200 (47.24)
Extended Stroke ES	mm (in)	1280 (50.39)
Max. Force	N (lbf)	255 (57.3)
Cont. Force	N (lbf)	35 (7.87)
Cont. Force with fan	N (lbf)	65 (14.6)
Max. Velocity	m/s (in/s)	3.9 (154)
Max. Current	A _{pk}	15
Cont. Current	A _{pk}	2.35
Cont. Current with fan	A _{pk}	4.10
Force Constant	N/A (lbf/A)	17 (3.83)
Border Force	%	67
Linearity	%	±0.1
Slider Length	mm (in)	1400 (55.12)
Slider Mass	g (lb)	3170 (6.99)

Ordering Information

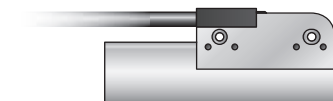

PS01-37Sx120F-HP-N	Stator HP with N-connector IP50	0150-1296
--------------------	---------------------------------	-----------



PL01-20x1400/1340-HP	High Performance Slider	0150-1516
PL02-20x1400/1340-HP	High Performance Slider, Heavy Duty	on request

Max. Stroke: 1480mm
Max. Force: 255N

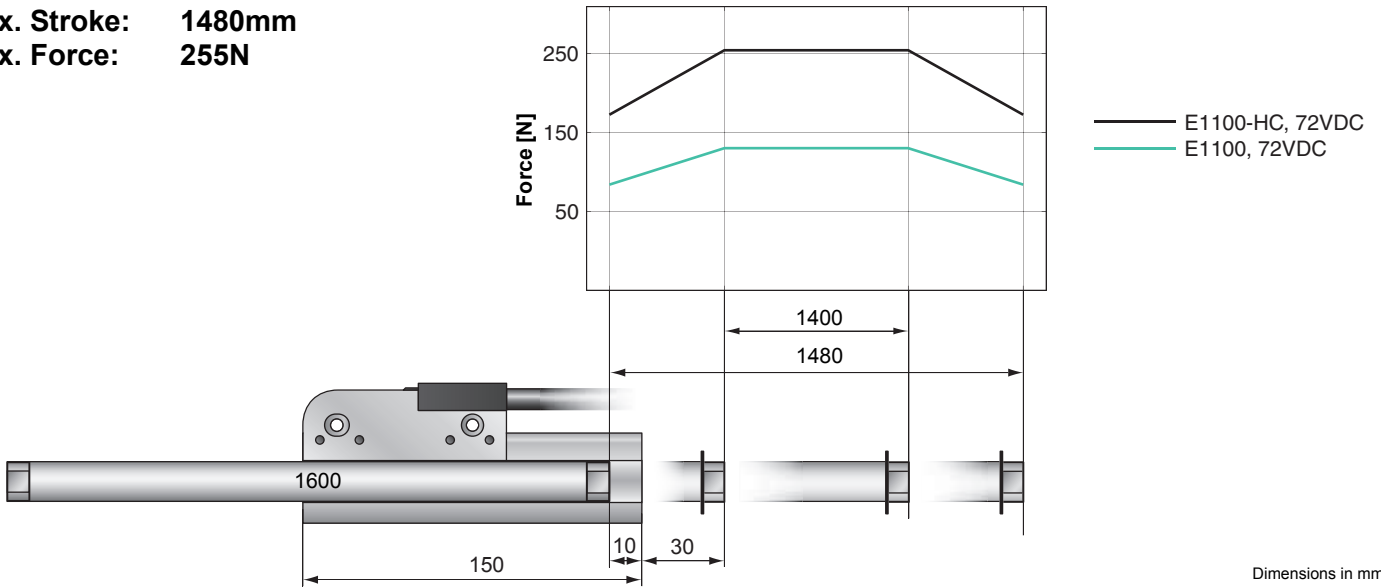

Motor Specification

Stator		Standard Winding
Slider		High Performance High Performance Heavy Duty
Standard Stroke SS	mm (in)	1400 (55.12)
Extended Stroke ES	mm (in)	1480 (58.27)
Max. Force	N (lbf)	255 (57.3)
Cont. Force	N (lbf)	35 (7.87)
Cont. Force with fan	N (lbf)	65 (14.6)
Max. Velocity	m/s (in/s)	3.9 (154)
Max. Current	A _{pk}	15
Cont. Current	A _{pk}	2.35
Cont. Current with fan	A _{pk}	4.10
Force Constant	N/A (lbf/A)	17 (3.83)
Border Force	%	67
Linearity	%	±0.1
Slider Length	mm (in)	1600 (62.99)
Slider Mass	g (lb)	3640 (8.02)

Ordering Information

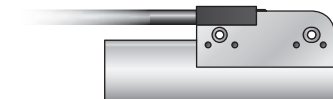

PS01-37Sx120F-HP-N	Stator HP with N-connector IP50	0150-1296
--------------------	---------------------------------	-----------



PL01-20x1600/1540-HP	High Performance Slider	0150-1517
PL02-20x1600/1540-HP	High Performance Slider, Heavy Duty	on request



N-Connector

Motor Connector Wiring

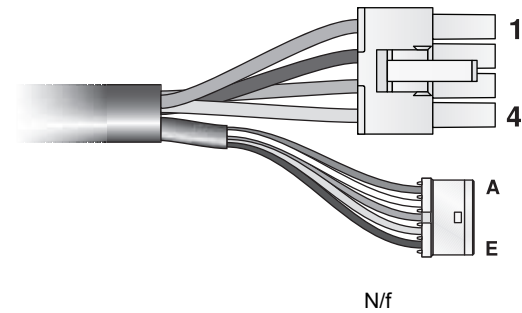

Power Connector

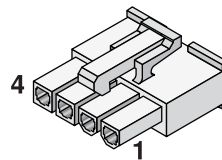

Pin 1	red	Phase 1+
Pin 2	pink	Phase 1-
Pin 3	blue	Phase 2+
Pin 4	grey	Phase 2-

Signal Connector

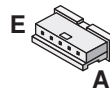

Pin A	white	+5V
Pin B	inner Shield	Ground
Pin C	yellow	Sensor Sin
Pin D	green	Sensor Cos
Pin E	black	Temp sensor
case	outerShield	shield

Ordering Information

High Flex Motor Cable directly to the Drive

Item	Description	Part Number
KS05-W/N-2	High Flex cable W/N, 2m	0150-2296
KS05-W/N-4	High Flex cable W/N, 4m	0150-2297
KS05-W/N-6	High Flex cable W/N, 6m	0150-2298
KS05-W/N-8	High Flex cable W/N, 8m	0150-2299
KS05-W/N-	High Flex cable W/N, Custom Length	0150-3412

Connectors & Cable

KS05-04/05	High Flex cable per m	0150-1938
KR05-W/R-	Robot cable W/R, per m	0150-3406
MC01-N/f	N/f connector	0150-3407
MC01-N/f-as	N/f connector, assembled	0150-3408

LinMot®

Stainless Steel Motors IP69K



Designed for harsh or aggressive environment



Hygienic design for food industry



Stainless steel housing EN1.4404 / AISI 316



Completely sealed, Protection rating IP69K



Available with integrated Fluid cooling

The linear motor technology for industrial applications

Stainless Steel Stator IP69K with bearings

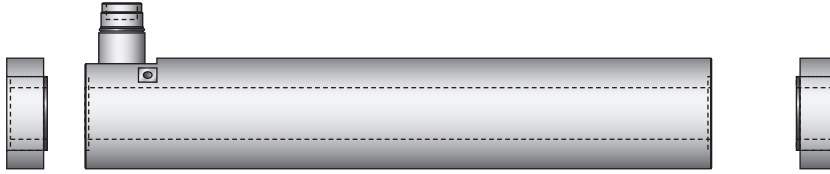

External bearings for mid range Strokes

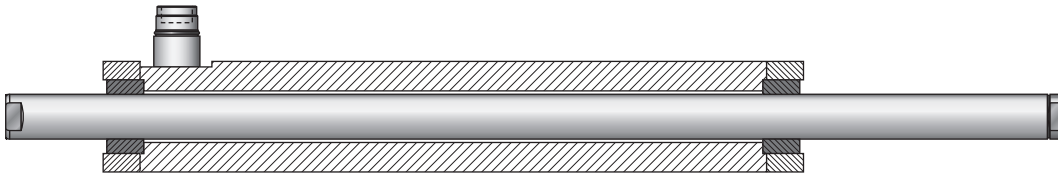

Internal/external bearings for short Strokes

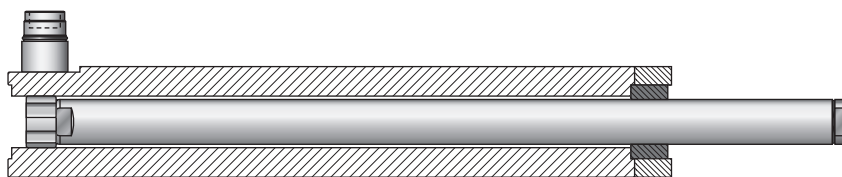

Internal bearings for short Strokes

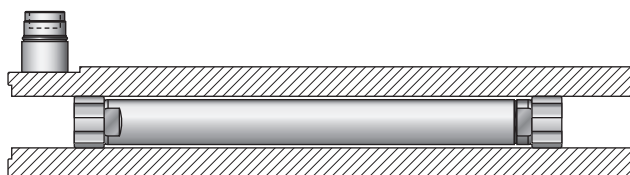

Application Example 1: Linear Stage IP69K

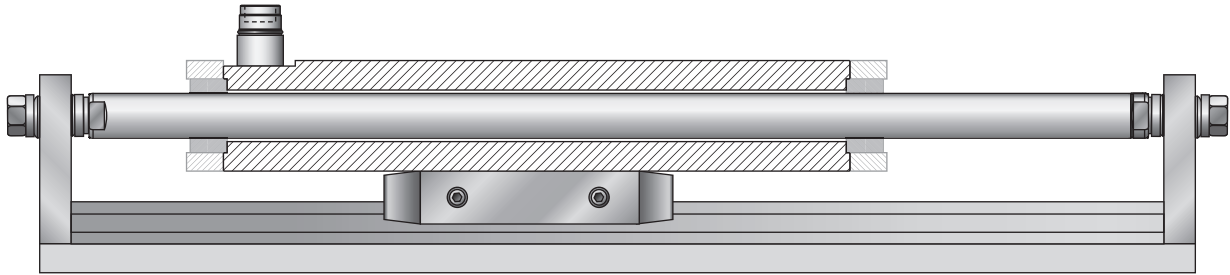

Application Example 2: Flow Control

1. Normal Operation

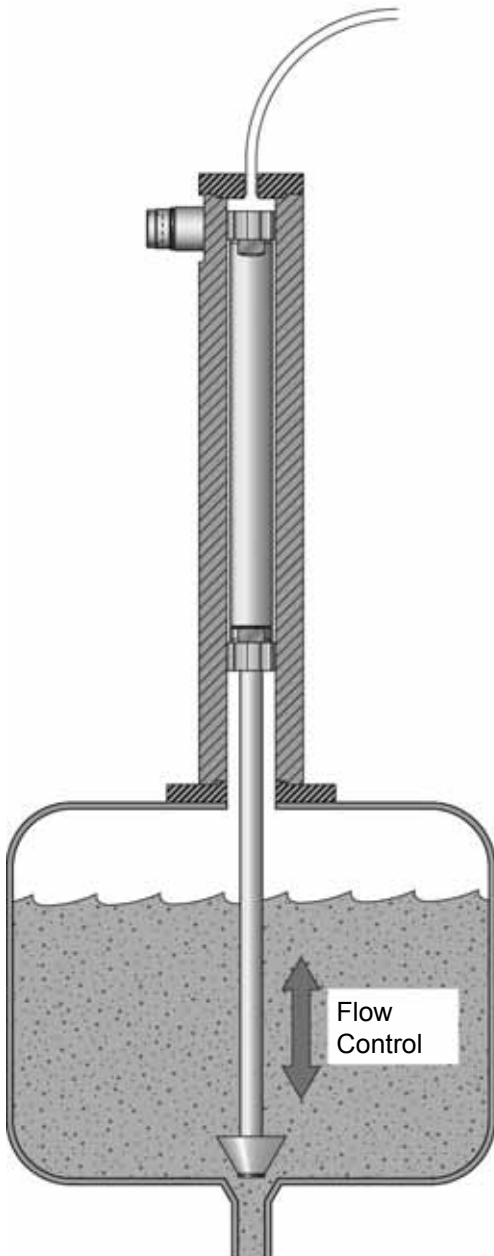

1. Cleaning Procedure

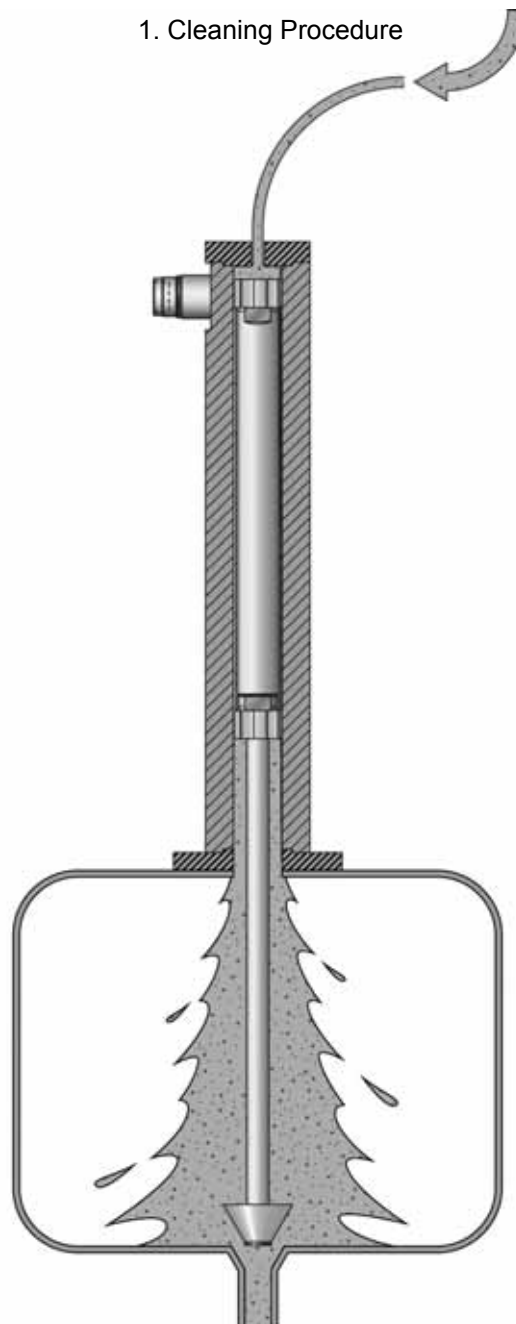

Applications:

- Clean Room
- Vacuum
- Aseptic

Max. Stroke: 680mm
Max. Force: 210N

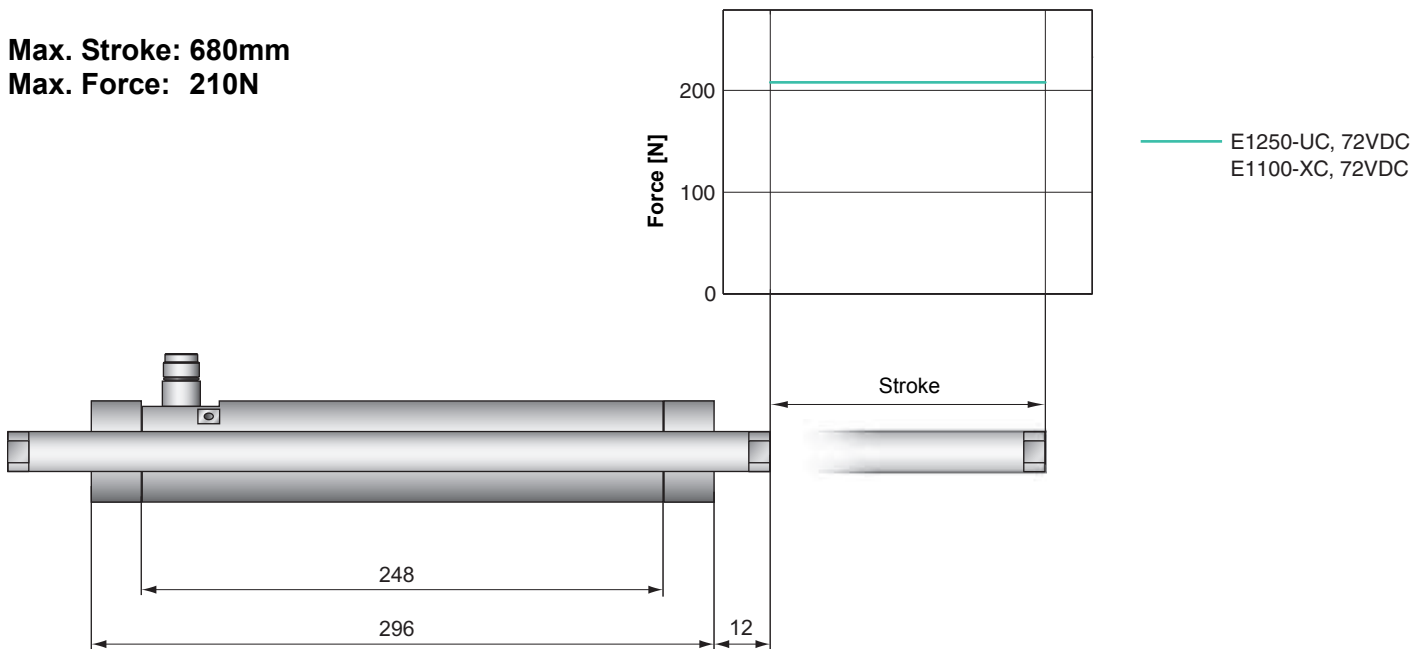

Dimensions in mm

Motor Specification*

		P10-37x120F/...x...-HP-SSC							
		75 (2.95)	180 (7.09)	280 (11.02)	380 (14.96)	480 (18.90)	580 (22.83)	680 (26.77)	
Stroke	mm (in)								
Max. Force E12x0 - UC	N (lbf)				210 (47.2)				
Max. Force E11x0 - XC	N (lbf)				210 (47.2)				
Cont. Force	N (lbf)				24 (5.4)				
Cont. Force Fluid cooling	N (lbf)				65 (14.6)				
Force Constant	N/A (lbf/A)				14 (3.1)				
Max. Current @ 72VDC	A				15				
Max. Velocity @ 72VDC	m/s (in/s)				- (-)				
Phase Resist. 25/80 °C	Ohm				2.5/3				
Phase Inductance	mH				1.6				
Thermal Resistance	°K/W				-				
Thermal Time Const.	sec				-				
Stator Diameter	mm (in)				48 (1.89)				
Stator Length	mm (in)				296 (11.65)				
Stator Mass	g (lb)				2200 (4.85)				
Slider Diameter	mm (in)				19 (0.75)				
Slider Length	mm (in)	395 (15.55)	500 (19.69)	600 (23.62)	700 (27.56)	800 (31.50)	900 (35.43)	1000 (39.37)	
Slider Mass	g (lb)	746 (1.64)	958 (2.11)	1167 (2.57)	1376 (3.03)	1586 (3.50)	1785 (3.94)	1980 (4.37)	
Position Repeatability	mm (in)				±0.05 (±0.0020)				
Linearity	%				±0.10				
Repeatability with EPS	mm (in)				±0.01 (±0.0004)				
Linearity with EPS	mm (in)				±0.01 (±0.0004)				

*for Motors with Bearings, other Values without Bearings (see LinMot Designer)

PS01-37x120F-HP-SSC

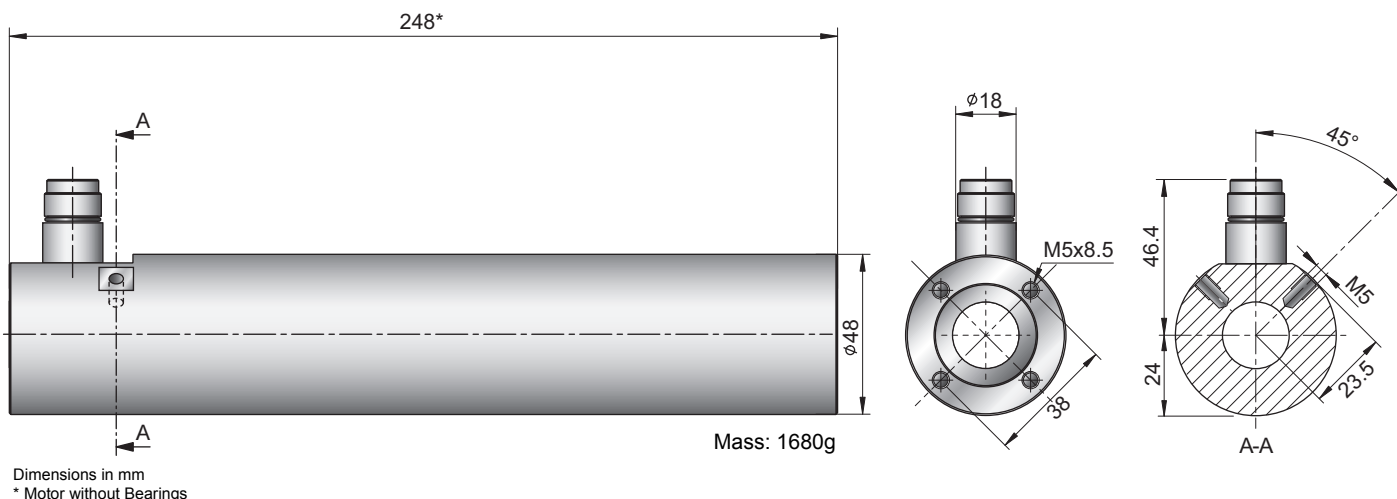

PL01-19x.../...

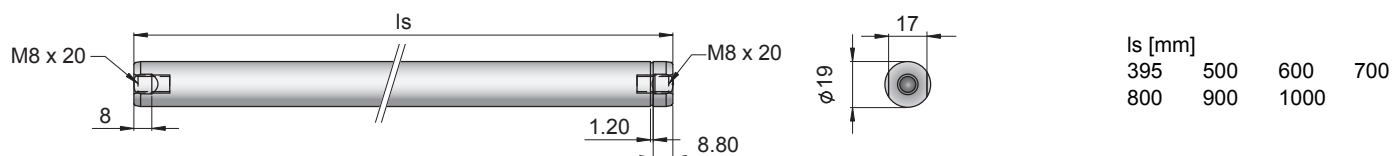

Linear Motor		Stator		Slider	
Type	Art. Nr.	Type	Art. No.	Type	Art No.
P01-37x120F/75x75-HP-SSC	-->			& PL01-19x395/320	0150-1452
P01-37x120F/180x180-HP-SSC	-->			& PL01-19x500/420	0150-1455
P01-37x120F/280x280-HP-SSC	-->	PS01-37x120F-HP-SSC-R	0150-1282	& PL01-19x600/520	0150-1456
P01-37x120F/380x380-HP-SSC	-->	PS01-37x120F-HP-SSC-R-FC	0150-1283	& PL01-19x700/620	0150-1457
P01-37x120F/480x480-HP-SSC	-->			& PL01-19x800/720	01-50-1458
P01-37x120F/580x580-HP-SSC	-->			& PL01-19x900/820	0150-1459
P01-37x120F/680x680-HP-SSC	-->			& PL01-19x1000/920	0150-1460

Connectors

Motor Connector Wiring

Ph 1+	red	1
Ph 1-	pink	2
Ph 2+	blue	3
Ph 2-	gray	4
+5VDC	white	A
GND	inner Shield	B
Sine	yellow	C
Cosine	green	D
Temp.	black	E
Shield	outer Shield	Case

Accessories

Plain Bearings

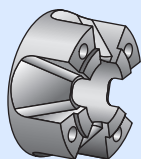

PB01-37x24-P-WD
Art. No. 0150-3299

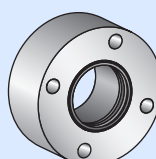

PB01-37x24-P-SSC
Art. No. 0150-3290

Connectors

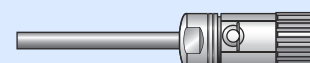

MC01-R/f-IP69K-SSC
Art. No. 0150-3347

MC01-R/f-IP69K-SSC-as
Art. No. 0150-3343

Max. Stroke: 980mm
Max. Force: 496N

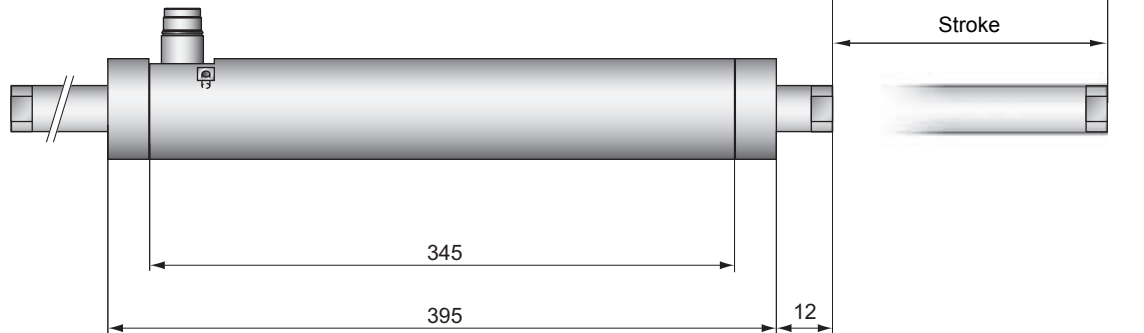

Dimensions in mm

Motor Specification*

		P01-48x240F/...x...-SSC							
		80 (3.15)	200 (7.87)	290 (11.42)	380 (14.96)	500 (19.69)	590 (23.23)	800 (31.50)	980 (38.58)
Stroke	mm (in)								
Max. Force E12x0 - UC	N (lbf)				496 (111.51)				
Max. Force E11x0 - XC	N (lbf)				477 (107.23)				
Cont. Force	N (lbf)				86 (19.33)				
Cont. Force Fluid cooling	N (lbf)				241 (54.18)				
Force Constant	N/A (lbf/A)				19.1 (4.29)				
Max. Current @ 72VDC	A				26				
Max. Velocity @ 72VDC	m/s (in/s)				3.4 (134)				
Phase Resist. 25/80 °C	Ohm				1.0/1.2				
Phase Inductance	mH				1.0				
Thermal Resistance	°K/W				- (-)				
Thermal Time Const.	sec				- (-)				
Stator Diameter	mm (in)				60 (2.36)				
Stator Length	mm (in)				345 (13.58)				
Stator Mass	g (lb)				3710 (8.18)				
Slider Diameter	mm (in)				27 (0.059)				
Slider Length	mm (in)	500(19.69)	620(24.41)	710(27.95)	800(31.50)	920(36.22)	1010(39.76)	1220(48.03)	1400(55.12)
Slider Mass	g (lb)	2010(4.43)	2530(5.58)	2920(6.44)	3310(7.30)	3830(8.44)	4220(9.30)	5130(11.31)	5910(13.03)
Position Repeatability	mm (in)				±0.05 (±0.0020)				
Linearity	%				±0.10				
Repeatability with EPS	mm (in)				±0.01 (±0.0004)				
Linearity with EPS	mm (in)				±0.01 (±0.0004)				

*for Motors with Bearings, other Values without Bearings (see LinMot Designer)

PS01-48x240F-SSC

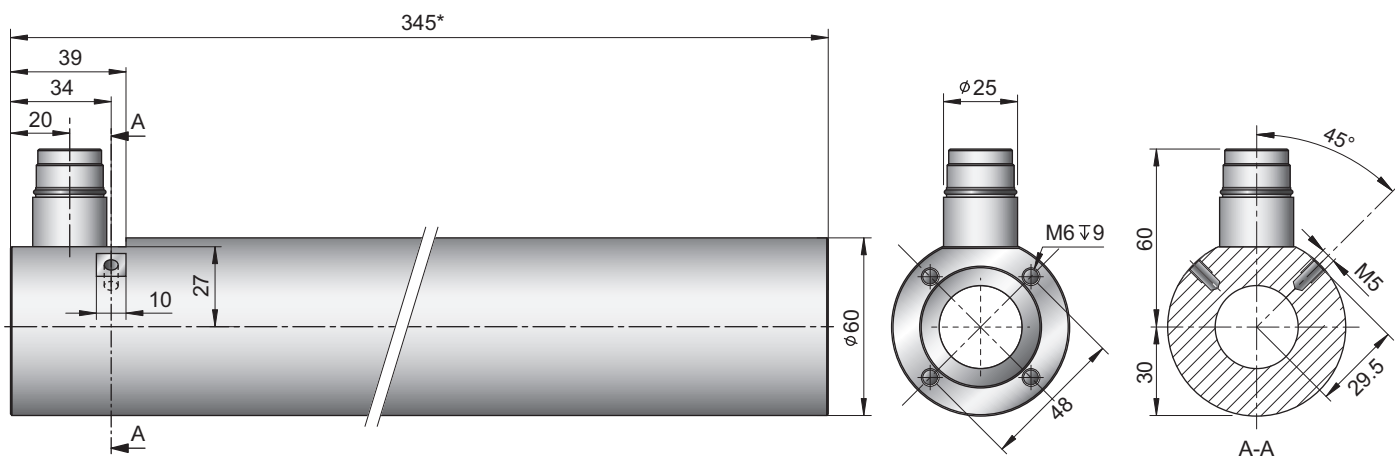

Dimensions in mm
* Motor without Bearings

PL01-27x.../...

Is [mm]			
500	620	710	800
920	1010	1220	1400

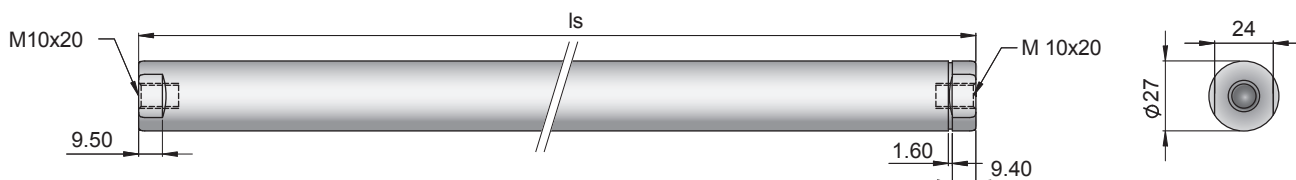

Linear Motor	Stator		Slider		
Type	Art. Nr.	Type	Art. No.	Type	Art No.
P01-48x240F/80x80-SSC	-->			& PL01-27x500/420	0150-1469
P01-48x240F/200x200-SSC	-->			& PL01-27x620/540	0150-1470
P01-48x240F/290x290-SSC	-->			& PL01-27x710/630	0150-1471
P01-48x240F/380x380-SSC	-->	PS01-48x240F-SSC-C	0150-1267	& PL01-27x800/720	0150-1472
P01-48x240F/500x500-SSC	-->	PS01-48x240F-SSC-C-FC	0150-1268	& PL01-27x920/840	0150-1447
P01-48x240F/590x590-SSC	-->			& PL01-27x1010/930	0150-1473
P01-48x240F/800x800-SSC	-->			& PL01-27x1220/1140	0150-1587
P01-48x240F/980x980-SSC	-->			& PL01-27x1400/1320	0150-1588

Connectors

Motor Connector Wiring

Ph 1+	red	1
Ph 1-	pink	2
Ph 2+	blue	3
Ph 2-	gray	4
+5VDC	white	A
GND	inner Shield	B
Sine	yellow	C
Cosine	green	D
Temp.	black	E
Shield	outer Shield	Case

Accessories

Plain Bearings

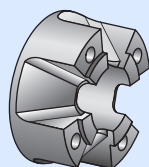

PB01-48x25-P-WD
Art. No. 0150-3271

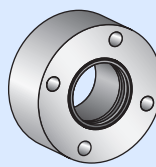

PB01-48x25-P-SSC
Art. No. 0150-3281

Connectors

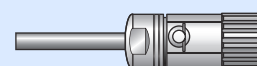

MC01-C/f-IP69K-SSC
Art. No. 0150-3306

MC01-C/f-IP69K-SSC-as
Art. No. 0150-3325

Max. Stroke: 860mm
Max. Force: 888N

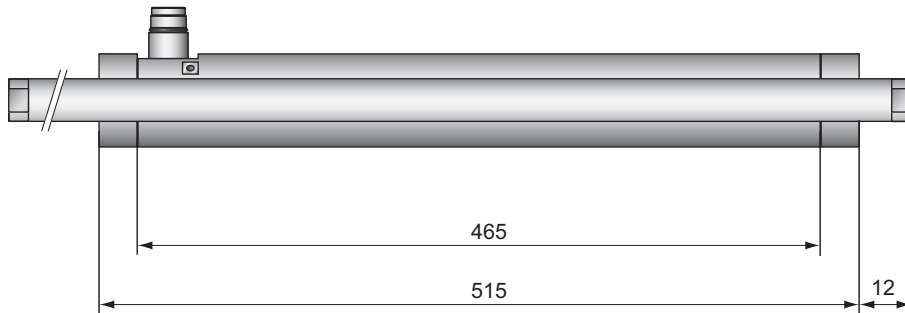
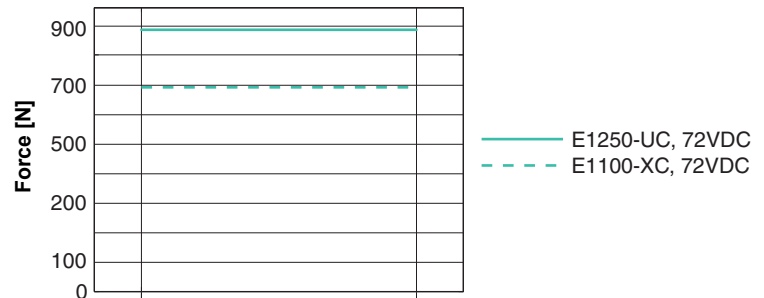

Dimensions in mm

Motor Specification*

		P01-48x360F/...x...-SSC							
Extended Stroke ES	mm (in)	80 (3.15)	170 (6.69)	260 (10.24)	380 (14.96)	470 (18.50)	680 (26.77)	860 (33.86)	
Max. Force E12x0 - UC	N (lbf)	888 (199.6)							
Max. Force E11x0 - XC	N (lbf)	693 (155.8)							
Cont. Force	N (lbf)	129 (29.0)							
Cont. Force Fluid cooling	N (lbf)	360 (80.9)							
Force Constant	N/A (lbf/A)	27.7 (6.23)							
Max. Current @ 72VDC	A	32							
Max. Velocity @ 72VDC	m/s (in/s)	2.35							
Phase Resist. 25/80 °C	Ohm	1.5/1.8							
Phase Inductance	mH	1.5							
Thermal Resistance	°K/W	- (-)							
Thermal Time Const.	sec	- (-)							
Stator Diameter	mm (in)	60 (2.36)							
Stator Length	mm (in)	465 (18.31)							
Stator Mass	g (lb)	5000 (11.02)							
Slider Diameter	mm (in)	27 (0.059)							
Slider Length	mm (in)	620(24.41)	710(27.95)	800(31.50)	920(36.22)	1010(39.76)	1220(48.03)	1400(55.12)	
Slider Mass	g (lb)	2530(5.58)	2920(6.44)	3310(7.30)	3830(8.44)	4220(9.30)	5130(11.31)	5910(13.03)	
Position Repeatability	mm (in)	±0.05 (±0.0020)							
Linearity	%	±0.10							
Repeatability with EPS	mm (in)	±0.01 (±0.0004)							
Linearity with EPS	mm (in)	±0.01 (±0.0004)							

*for Motors with Bearings, other Values without Bearings (see LinMot Designer)

PS01-48x360F-SSC

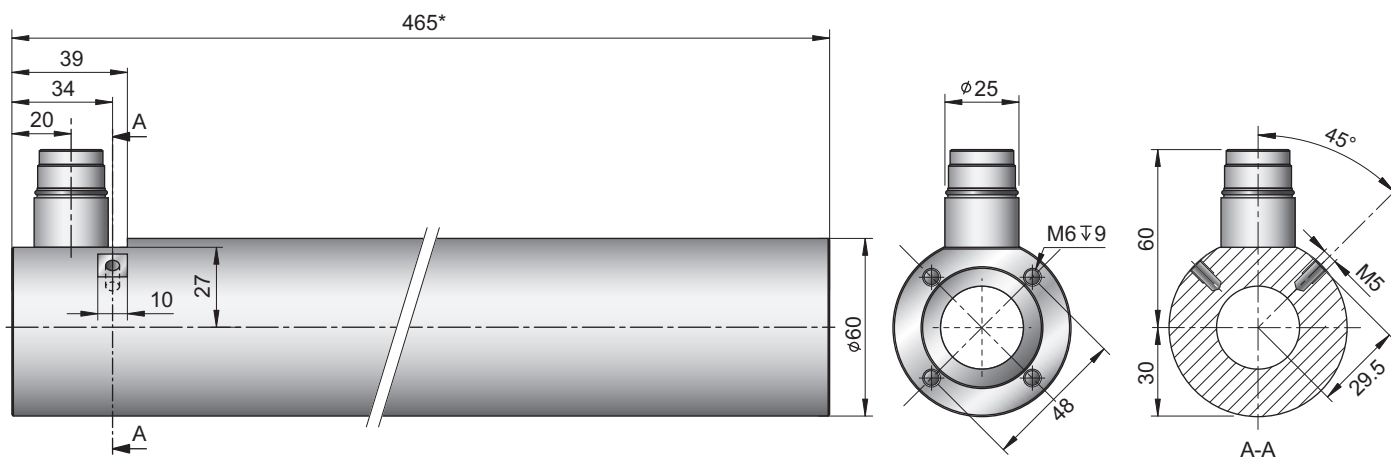

Dimensions in mm
* Motor without Bearings

PL01-27x.../...

ls [mm]
620 710 800 920
1010 1220 1400

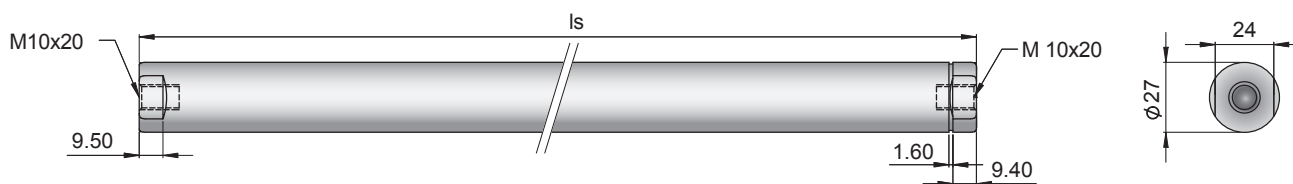

Linear Motor Type	Art. Nr.	Stator Type	Art. No.	Slider Type	Art No.
P01-48x360F/80x80-SSC	-->			& PL01-27x620/540	0150-1470
P01-48x360F/170x170-SSC	-->			& PL01-27x710/630	0150-1471
P01-48x360F/260x260-SSC	-->			& PL01-27x800/720	0150-1472
P01-48x360F/380x380-SSC	-->	PS01-48x360F-SSC-C	0150-1270	& PL01-27x920/840	0150-1447
P01-48x360F/470x470-SSC	-->	PS01-48x360F-SSC-C-FC	0150-1271	& PL01-27x1010/930	0150-1473
P01-48x360F/680x680-SSC	-->			& PL01-27x1220/1140	0150-1587
P01-48x360F/860x860-SSC	-->			& PL01-27x1400/1320	0150-1588

Connectors

Motor Connector Wiring

Ph 1+	red	1
Ph 1-	pink	2
Ph 2+	blue	3
Ph 2-	gray	4
+5VDC	white	A
GND	inner Shield	B
Sine	yellow	C
Cosine	green	D
Temp.	black	E
Shield	outer Shield	Case

Accessories

Plain Bearings

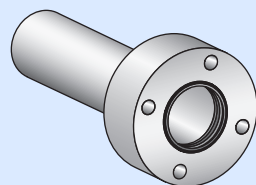

PB 01-48x25-80-P-SSC
Art. No. 0150-3271

Connectors

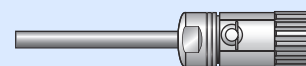

MC01-C/f-IP69K-SSC
Art. No. 0150-3306

MC01-C/f-IP69K-SSC-as
Art. No. 0150-3325

PB02-37x24-P-WD

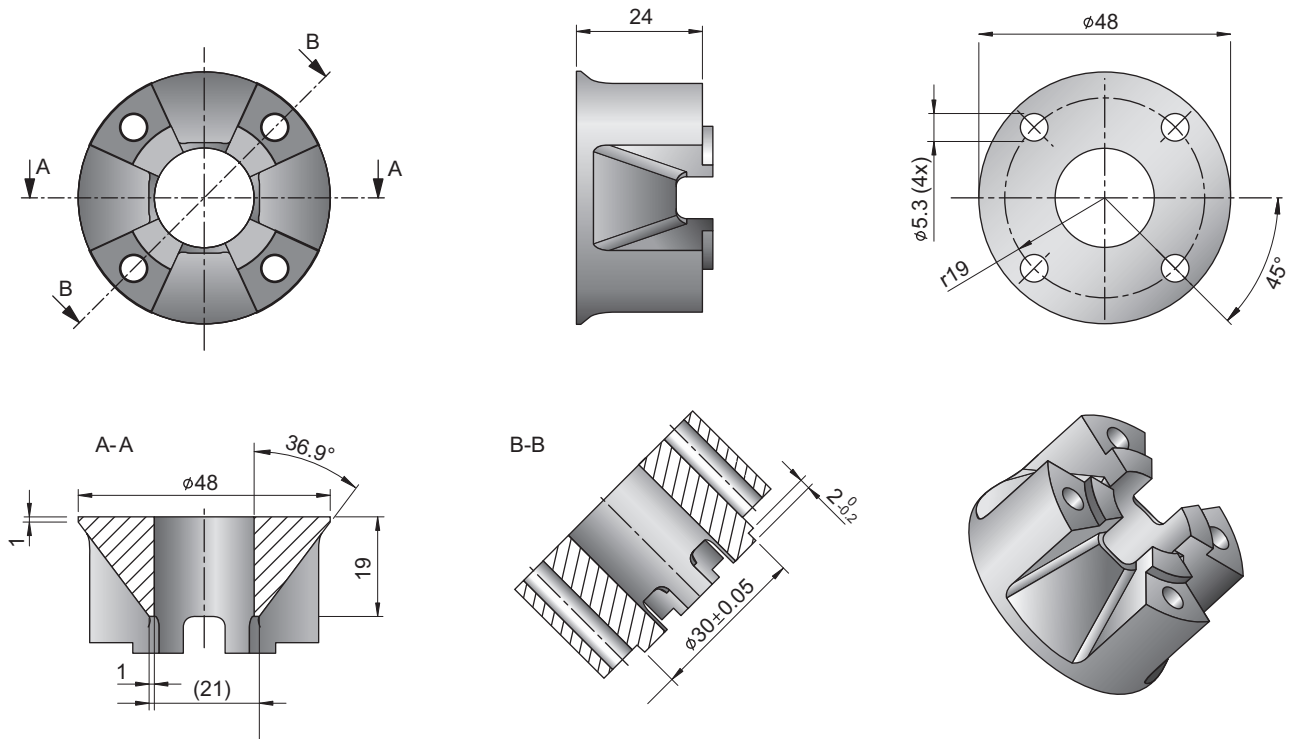

PB02-48x25-P-WD

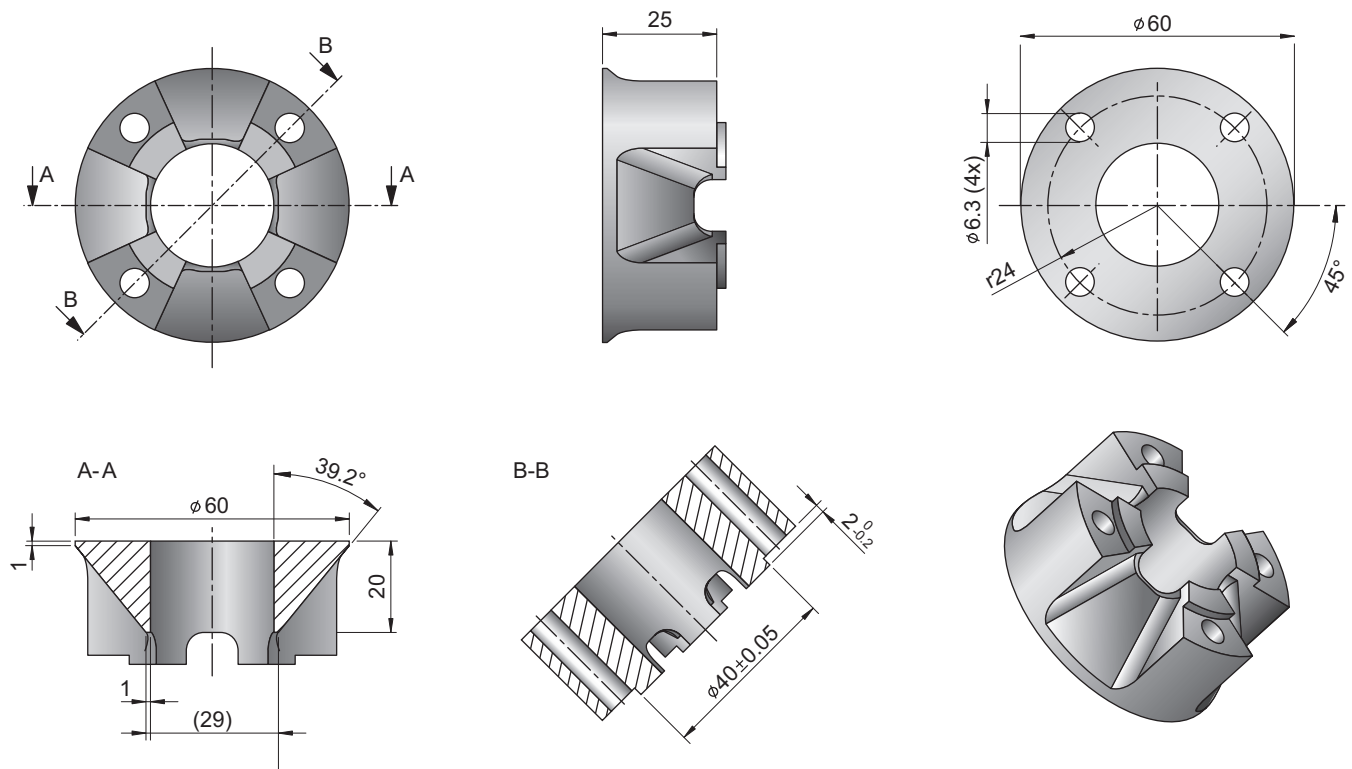

Ordering information

Item	Description	Part Number
PB01-37x24-P-WD	Plain Bearing for PS01-37x...-SSC (synthetical, FDA materials)	0150-3299
PB01-48x25-P-WD	Plain Bearing for PS01-48x...-SSC (synthetical, FDA materials)	0150-3271

PB01-37x24-P-SSC

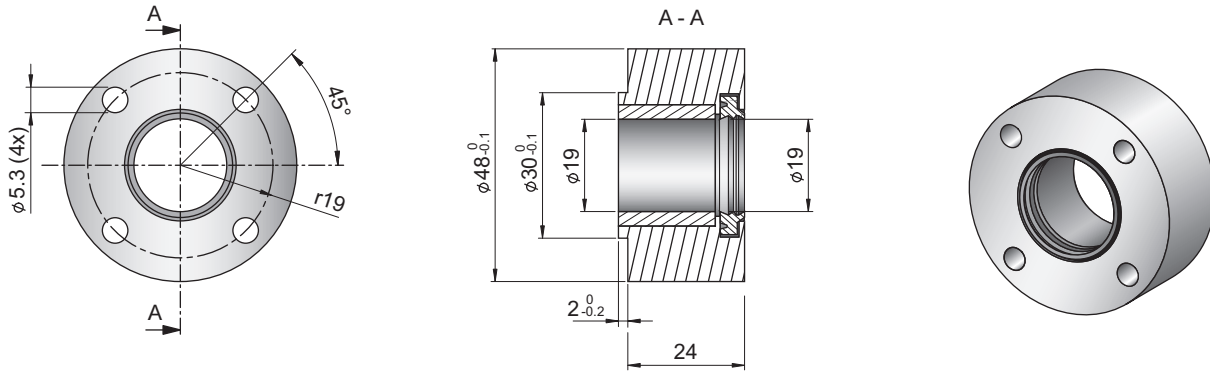

PB01-48x25-P-SSC

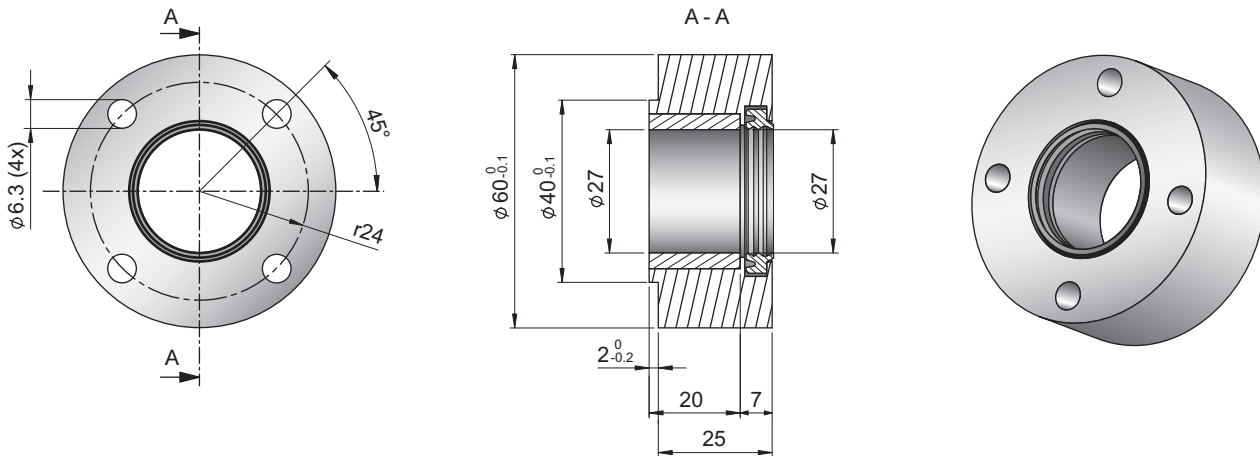

PB01-48x25-80-P-SSC

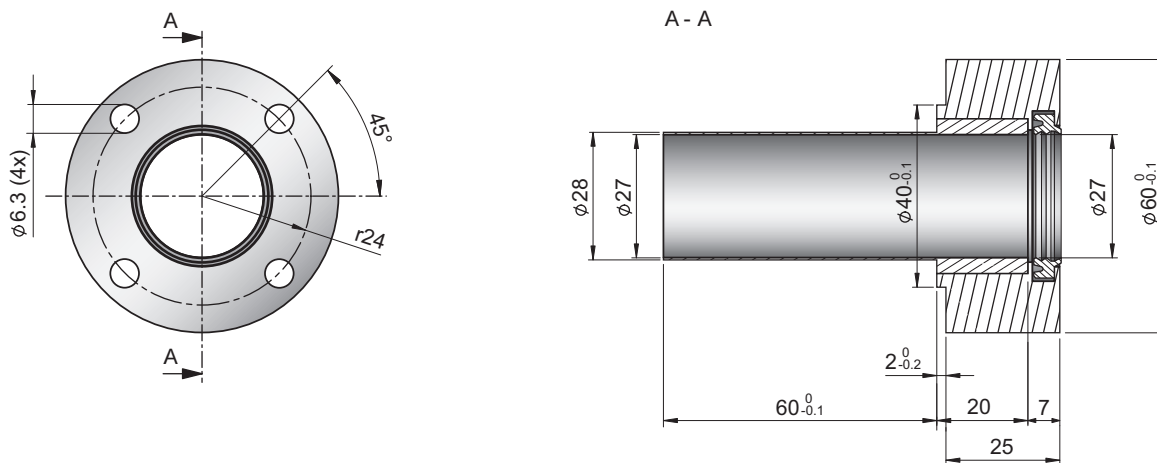

Ordering information

Item	Description	Part Number
PB01-37x24-P-SSC	Plain Bearing for PS01-37x120...-SSC (synthetical, FDA materials)	0150-3290
PB01-48x25-P-SSC	Plain Bearing for PS01-48x240...-SSC (synthetical, FDA materials)	0150-3281
PB01-48x25-80-P-SSC	Plain Bearing for PS01-48x360...-SSC (synthetical, FDA materials)	0150-3413

LinMot®

PRELIMINARY

Linear Motors with ATEX-Certification



Designed for explosion proof environment



Categories: gas zones 1/2, dust zones 21/22



Stainless steel housing EN1.4404 / AISI 316



Completely sealed, protection IP69K



Available with integrated Fluid cooling

The linear motor technology for industrial applications

Max. Stroke: 680mm
Max. Force: 210N

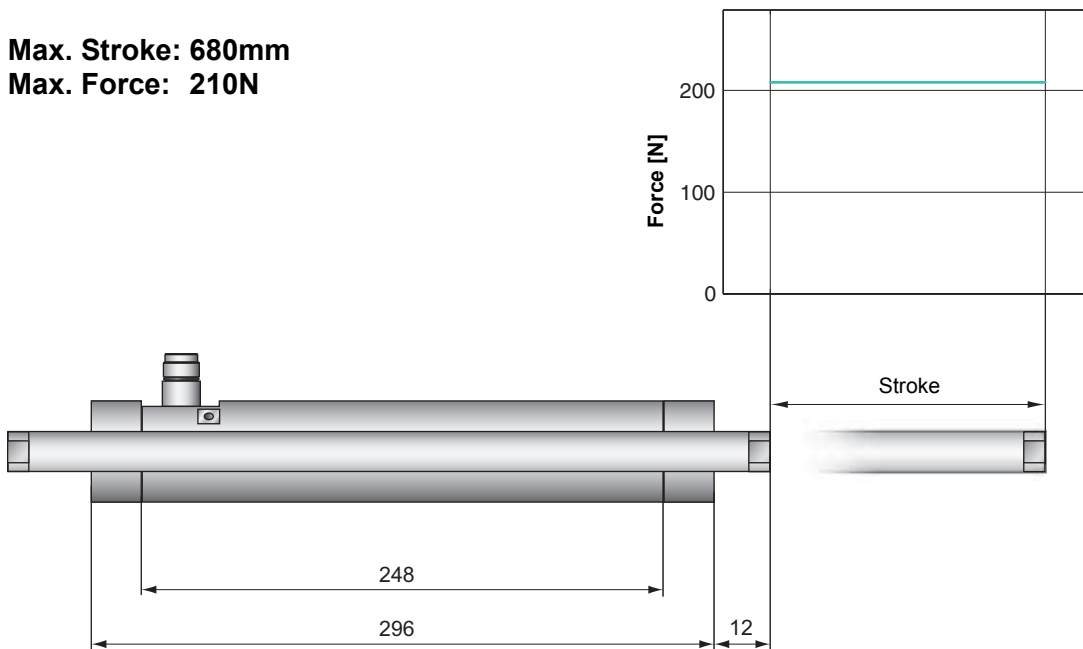

Dimensions in mm

Motor Specification*

		P01-37x120F/...x...-HP-ATEX							
		75 (2.95)	180 (7.09)	280 (11.02)	380 (14.96)	480 (18.90)	580 (22.83)	680 (26.77)	
Stroke	mm (in)								
Max. Force E12x0 - UC	N (lbf)				210 (47.2)				
Max. Force E11x0 - XC	N (lbf)				210 (47.2)				
Cont. Force	N (lbf)				24 (5.4)				
Cont. Force Liquid cooling	N (lbf)				65 (14.6)				
Force Constant	N/A (lbf/A)				14 (3.1)				
Max. Current @ 72VDC	A				15				
Max. Velocity @ 72VDC	m/s (in/s)				- (-)				
Phase Resist. 25/80 °C	Ohm				2.5/3				
Phase Inductance	mH				1.6				
Thermal Resistance	°K/W				-				
Thermal Time Const.	sec				-				
Stator Diameter	mm (in)				48 (1.89)				
Stator Length	mm (in)				296 (11.65)				
Stator Mass	g (lb)				2200 (4.85)				
Slider Diameter	mm (in)				19 (0.75)				
Slider Length	mm (in)	395 (15.55)	500 (19.69)	600 (23.62)	700 (27.56)	800 (31.50)	900 (35.43)	1000 (39.37)	
Slider Mass	g (lb)	746 (1.64)	958 (2.11)	1167 (2.57)	1376 (3.03)	1586 (3.50)	1785 (3.94)	1980 (4.37)	
Position Repeatability	mm (in)				±0.05 (±0.0020)				
Linearity	%				±0.10				
Repeatability with EPS	mm (in)				±0.01 (±0.0004)				
Linearity with EPS	mm (in)				±0.01 (±0.0004)				

Ex II 2 G Ex e IIC T4

Ex III 2 G Ex e IIIC T135° IP66

*for Motors with Bearings, other Values without Bearings (see LinMot Designer)

PS01-37x120F-HP-ATEX

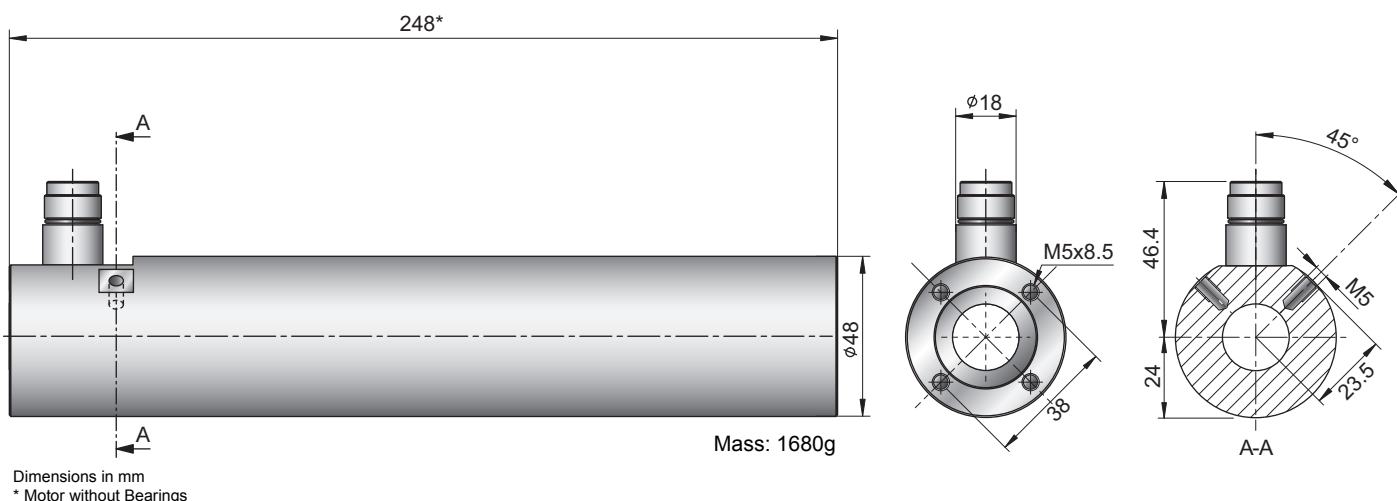

PL01-19x.../...

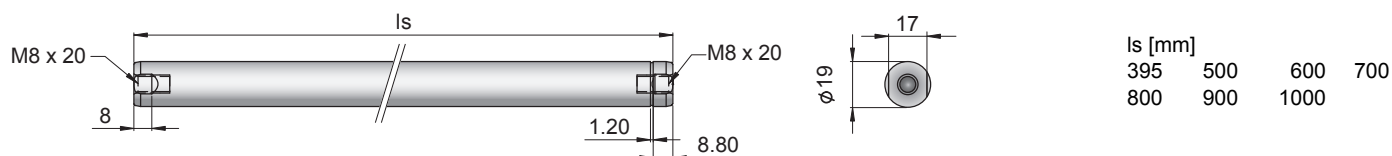

Linear Motor		Stator		Slider	
Type	Art. Nr.	Type	Art. No.	Type	Art No.
P01-37x120F/75x75-HP-ATEX	-->			& PL01-19x395/320	0150-1452
P01-37x120F/180x180-HP-ATEX	-->			& PL01-19x500/420	0150-1455
P01-37x120F/280x280-HP-ATEX	-->			& PL01-19x600/520	0150-1456
P01-37x120F/380x380-HP-ATEX	-->	PS01-37x120F-HP-ATEX-R-FC	0150-1298	& PL01-19x700/620	0150-1457
P01-37x120F/480x480-HP-ATEX	-->			& PL01-19x800/720	01-50-1458
P01-37x120F/580x580-HP-ATEX	-->			& PL01-19x900/820	0150-1459
P01-37x120F/680x680-HP-ATEX	-->			& PL01-19x1000/920	0150-1460

Connectors

Motor Connector Wiring

Ph 1+	red	1
Ph 1-	pink	2
Ph 2+	blue	3
Ph 2-	gray	4
+5VDC	white	A
GND	inner Shield	B
Sine	yellow	C
Cosine	green	D
Temp.	black	E
Shield	outer Shield	Case

Accessories

Plain Bearing

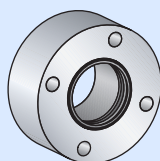

PB 01-37x24-P-SSC
Art. No. 0150-3290

Connector

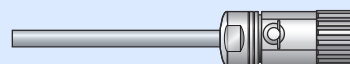

MC01-R/f-IP69K-SSC
Art. No. 0150-3347

MC01-R/f-IP69K-SSC-as
Art. No. 0150-3343

Max. Stroke: 980mm
Max. Force: 496N

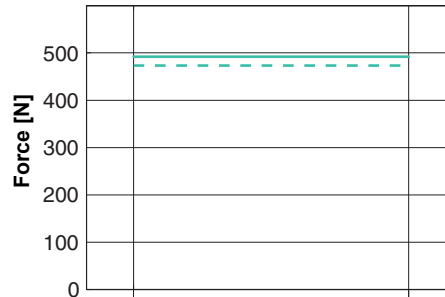

— E1250-UC, 72VDC
 - - - E1100-XC, 72VDC

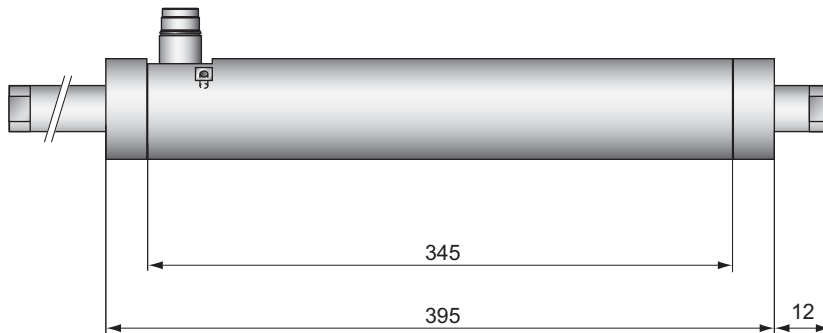

Dimensions in mm



Motor Specification*

		P01-48x240F/...x...-ATEX							
Stroke	mm (in)	80 (3.15)	200 (7.87)	290 (11.42)	380 (14.96)	500 (19.69)	590 (23.23)	800 (31.50)	980 (38.58)
Max. Force E12x0 - UC	N (lbf)	496 (111.51)							
Max. Force E11x0 - XC	N (lbf)	477 (107.23)							
Cont. Force	N (lbf)	86 (19.33)							
Cont. Force Liquid cooling	N (lbf)	241 (54.18)							
Force Constant	N/A (lbf/A)	19.1 (4.29)							
Max. Current @ 72VDC	A	26							
Max. Velocity @ 72VDC	m/s (in/s)	3.4 (134)							
Phase Resist. 25/80 °C	Ohm	1.0/1.2							
Phase Inductance	mH	1.0							
Thermal Resistance	°K/W	- (-)							
Thermal Time Const.	sec	- (-)							
Stator Diameter	mm (in)	60 (2.36)							
Stator Length	mm (in)	345 (13.58)							
Stator Mass	g (lb)	3710 (8.18)							
Slider Diameter	mm (in)	27 (0.059)							
Slider Length	mm (in)	500(19.69)	620(24.41)	710(27.95)	800(31.50)	920(36.22)	1010(39.76)	1220(48.03)	1400(55.12)
Slider Mass	g (lb)	2010(4.43)	2530(5.58)	2920(6.44)	3310(7.30)	3830(8.44)	4220(9.30)	5130(11.31)	5910(13.03)
Position Repeatability	mm (in)	±0.05 (±0.0020)							
Linearity	%	±0.10							
Repeatability with EPS	mm (in)	±0.01 (±0.0004)							
Linearity with EPS	mm (in)	±0.01 (±0.0004)							



*for Motors with Bearings, other Values without Bearings (see LinMot Designer)

PS01-48x240F-ATEX

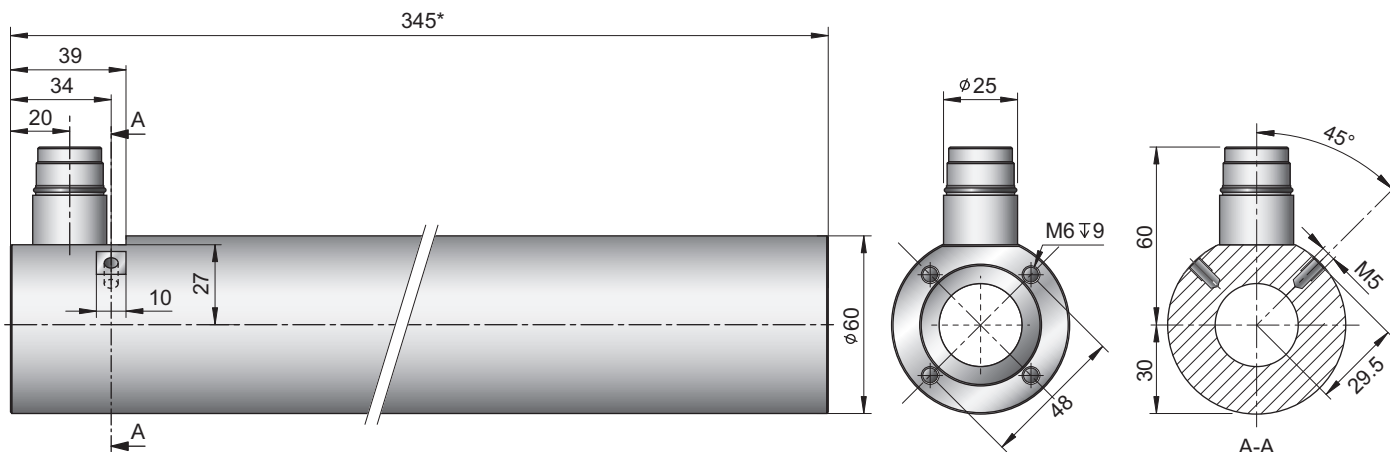

Dimensions in mm
* Motor without Bearings

PL01-27x.../...

Is [mm]			
500	620	710	800
920	1010	1220	1400

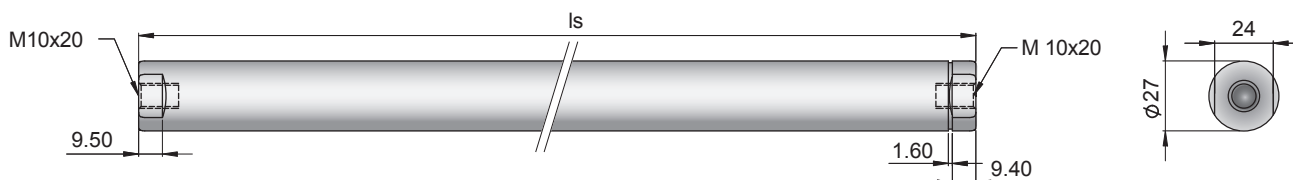

Linear Motor	Stator		Slider	
Type	Art. Nr.	Type	Art. No.	Art No.
P01-48x240F/80x80-ATEX	-->		& PL01-27x500/420	0150-1469
P01-48x240F/200x200-ATEX	-->		& PL01-27x620/540	0150-1470
P01-48x240F/290x290-ATEX	-->		& PL01-27x710/630	0150-1471
P01-48x240F/380x380-ATEX	-->	PS01-48x240F-ATEX-C-FC	0150-1299 & PL01-27x800/720	0150-1472
P01-48x240F/500x500-ATEX	-->		& PL01-27x920/840	0150-1447
P01-48x240F/590x590-ATEX	-->		& PL01-27x1010/930	0150-1473
P01-48x240F/800x800-ATEX	-->		& PL01-27x1220/1140	0150-1587
P01-48x240F/980x980-ATEX	-->		& PL01-27x1400/1320	0150-1588

Connectors

Motor Connector Wiring

Ph 1+	red	1
Ph 1-	pink	2
Ph 2+	blue	3
Ph 2-	gray	4
+5VDC	white	A
GND	inner Shield	B
Sine	yellow	C
Cosine	green	D
Temp.	black	E
Shield	outer Shield	Case

Accessories

Plain Bearing

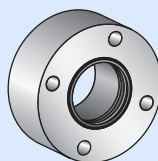

PB 01-48x25-P-SSC
Art. No. 0150-3281

Connector

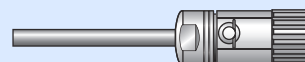

MC01-C/f-IP69K-SSC
Art. No. 0150-3306

MC01-C/f-IP69K-SSC-as
Art. No. 0150-3325

Max. Stroke: 860mm
Max. Force: 888N

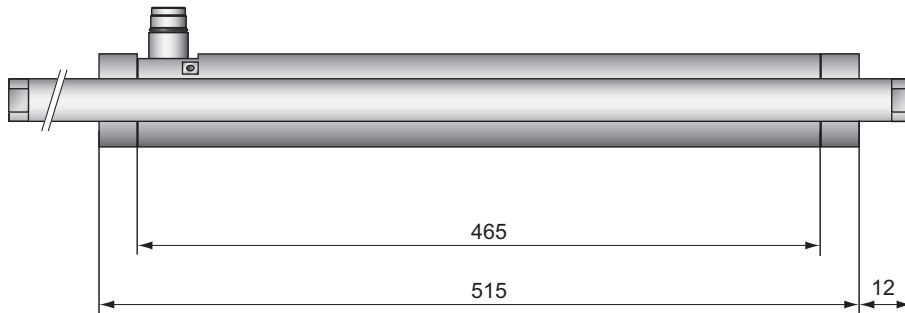

Dimensions in mm

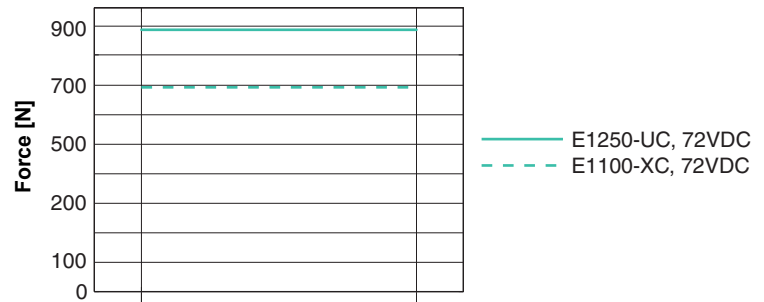

Motor Specification*

		P01-48x360F/...x...-ATEX							
Extended Stroke ES	mm (in)	80 (3.15)	170 (6.69)	260 (10.24)	380 (14.96)	470 (18.50)	680 (26.77)	860 (33.86)	
Max. Force E12x0 - UC	N (lbf)				888 (199.6)				
Max. Force E11x0 - XC	N (lbf)				693 (155.8)				
Cont. Force	N (lbf)				129 (29.0)				
Cont. Force Liquid cooling	N (lbf)				360 (80.9)				
Force Constant	N/A (lbf/A)				27.7 (6.23)				
Max. Current @ 72VDC	A				32				
Max. Velocity @ 72VDC	m/s (in/s)				2.35				
Phase Resist. 25/80 °C	Ohm				1.5/1.8				
Phase Inductance	mH				1.5				
Thermal Resistance	°K/W				- (-)				
Thermal Time Const.	sec				- (-)				
Stator Diameter	mm (in)				60 (2.36)				
Stator Length	mm (in)				465 (18.31)				
Stator Mass	g (lb)				5000 (11.02)				
Slider Diameter	mm (in)				27 (0.059)				
Slider Length	mm (in)	620(24.41)	710(27.95)	800(31.50)	920(36.22)	1010(39.76)	1220(48.03)	1400(55.12)	
Slider Mass	g (lb)	2530(5.58)	2920(6.44)	3310(7.30)	3830(8.44)	4220(9.30)	5130(11.31)	5910(13.03)	
Position Repeatability	mm (in)				±0.05 (±0.0020)				
Linearity	%				±0.10				
Repeatability with EPS	mm (in)				±0.01 (±0.0004)				
Linearity with EPS	mm (in)				±0.01 (±0.0004)				



*for Motors with Bearings, other Values without Bearings (see LinMot Designer)

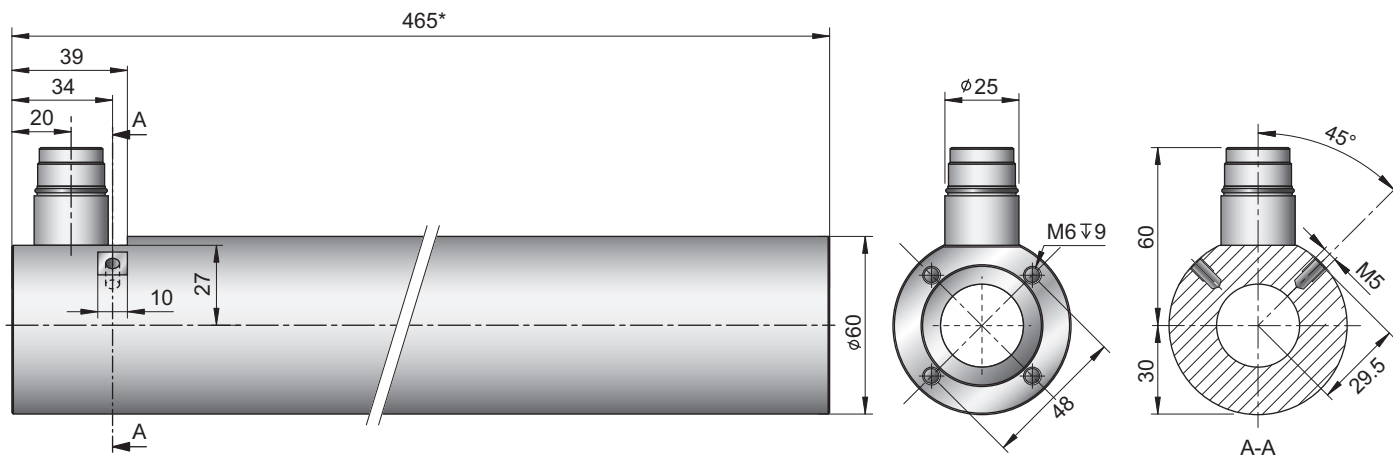

Dimensions in mm
* Motor without Bearings

PL01-27x.../...

ls [mm]
620 710 800 920
1010 1220 1400

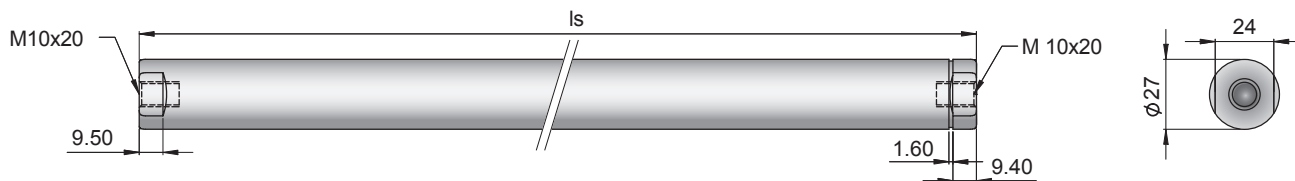

Linear Motor Type	Art. Nr.	Stator Type	Art. No.	Slider Type	Art No.
P01-48x360F/80x80-ATEX	-->			& PL01-27x620/540	0150-1470
P01-48x360F/170x170-ATEX	-->			& PL01-27x710/630	0150-1471
P01-48x360F/260x260-ATEX	-->			& PL01-27x800/720	0150-1472
P01-48x360F/380x380-ATEX	-->	PS01-48x360F-ATEX-C-FC	0150-1300	& PL01-27x920/840	0150-1447
P01-48x360F/470x470-ATEX	-->			& PL01-27x1010/930	0150-1473
P01-48x360F/680x680-ATEX	-->			& PL01-27x1220/1140	0150-1587
P01-48x360F/860x860-ATEX	-->			& PL01-27x1400/1320	0150-1588

Connectors

Motor Connector Wiring

Ph 1+	red	1
Ph 1-	pink	2
Ph 2+	blue	3
Ph 2-	gray	4
+5VDC	white	A
GND	inner Shield	B
Sine	yellow	C
Cosine	green	D
Temp.	black	E
Shield	outer Shield	Case

Accessories

Plain Bearing

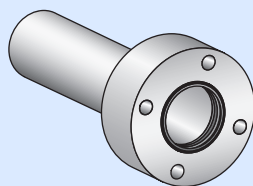

PB 01-48x25-80-P-SSC
Art. No. 0150-3213

Connector

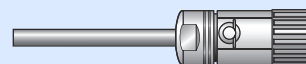

MC01-C/f-IP69K-SSC
Art. No. 0150-3306

MC01-C/f-IP69K-SSC-as
Art. No. 0150-3325

External bearings

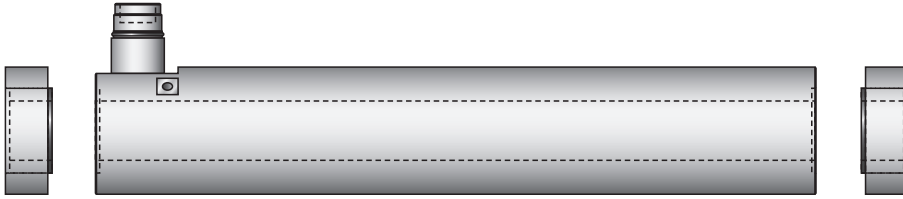

ATEX Stator with bearings

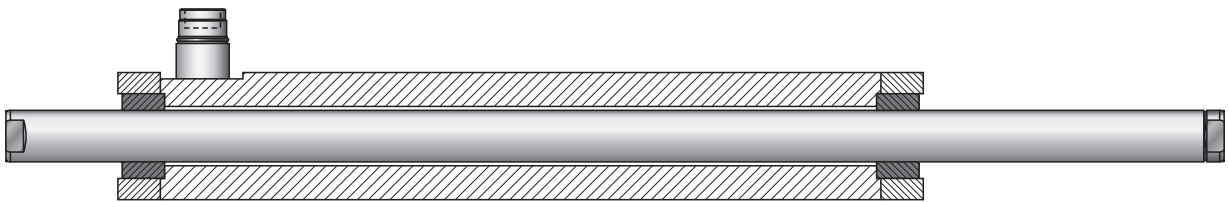

Application Example: Linear Stage

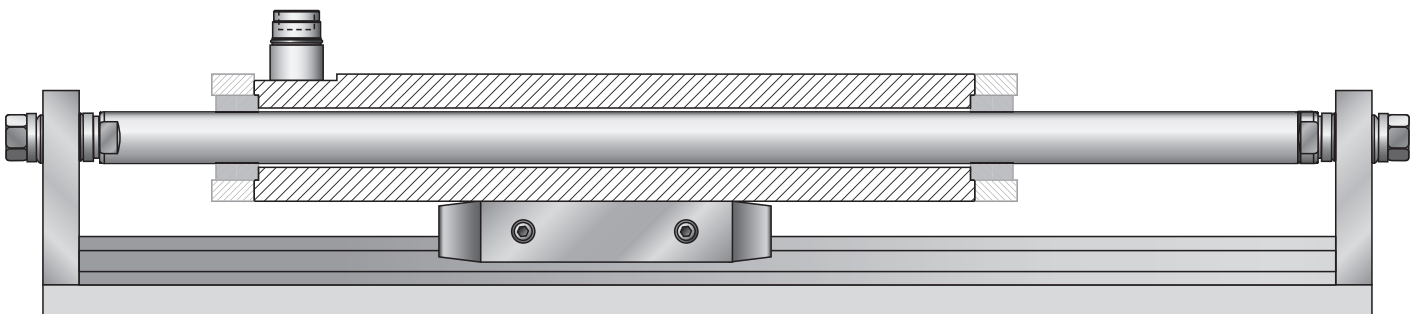

PB01-37x24-P-SSC

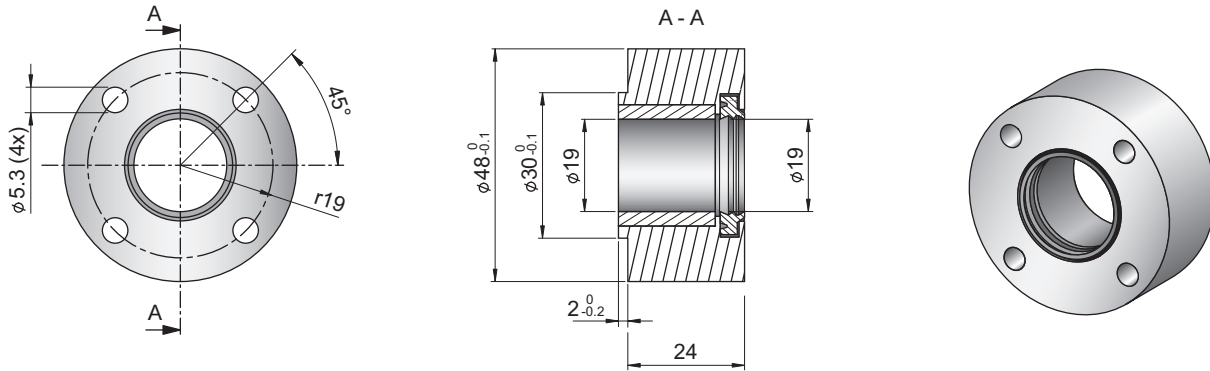

PB01-48x25-P-SSC

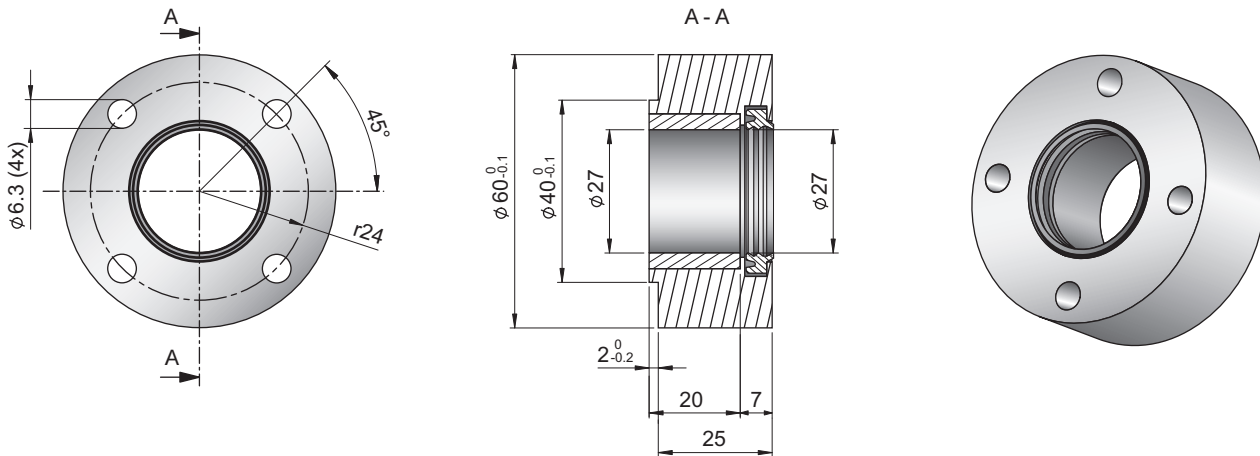

PB01-48x25-80-P-SSC

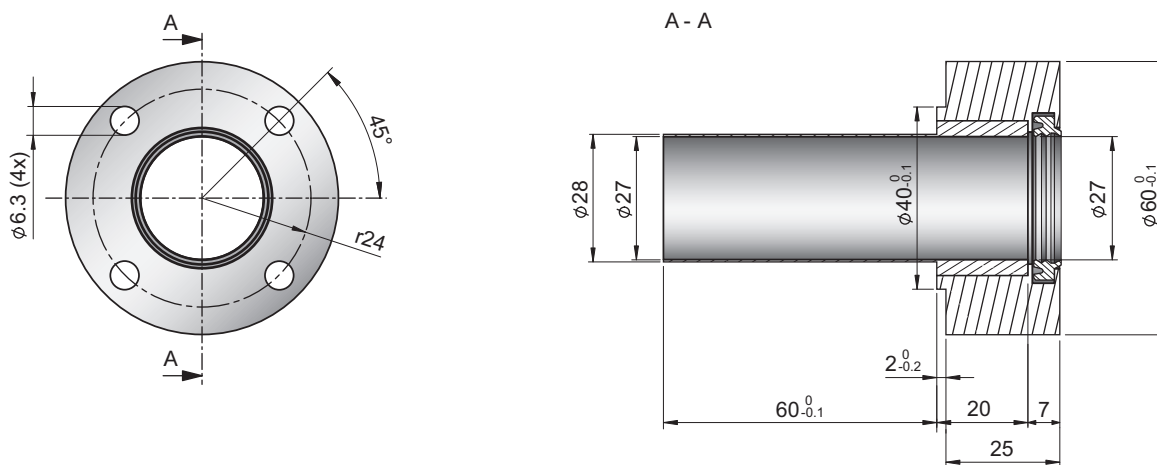

Ordering information

Item	Description	Part Number
PB01-37x24-P-SSC	Plain Bearing for PS01-37x120...-SSC (synthetical, FDA materials)	0150-3290
PB01-48x25-P-SSC	Plain Bearing for PS01-48x240...-SSC (synthetical, FDA materials)	0150-3281
PB01-48x25-80-P-SSC	Plain Bearing for PS01-48x360...-SSC (synthetical, FDA materials)	0150-3413

LinMot®

Linear-Rotary Motors

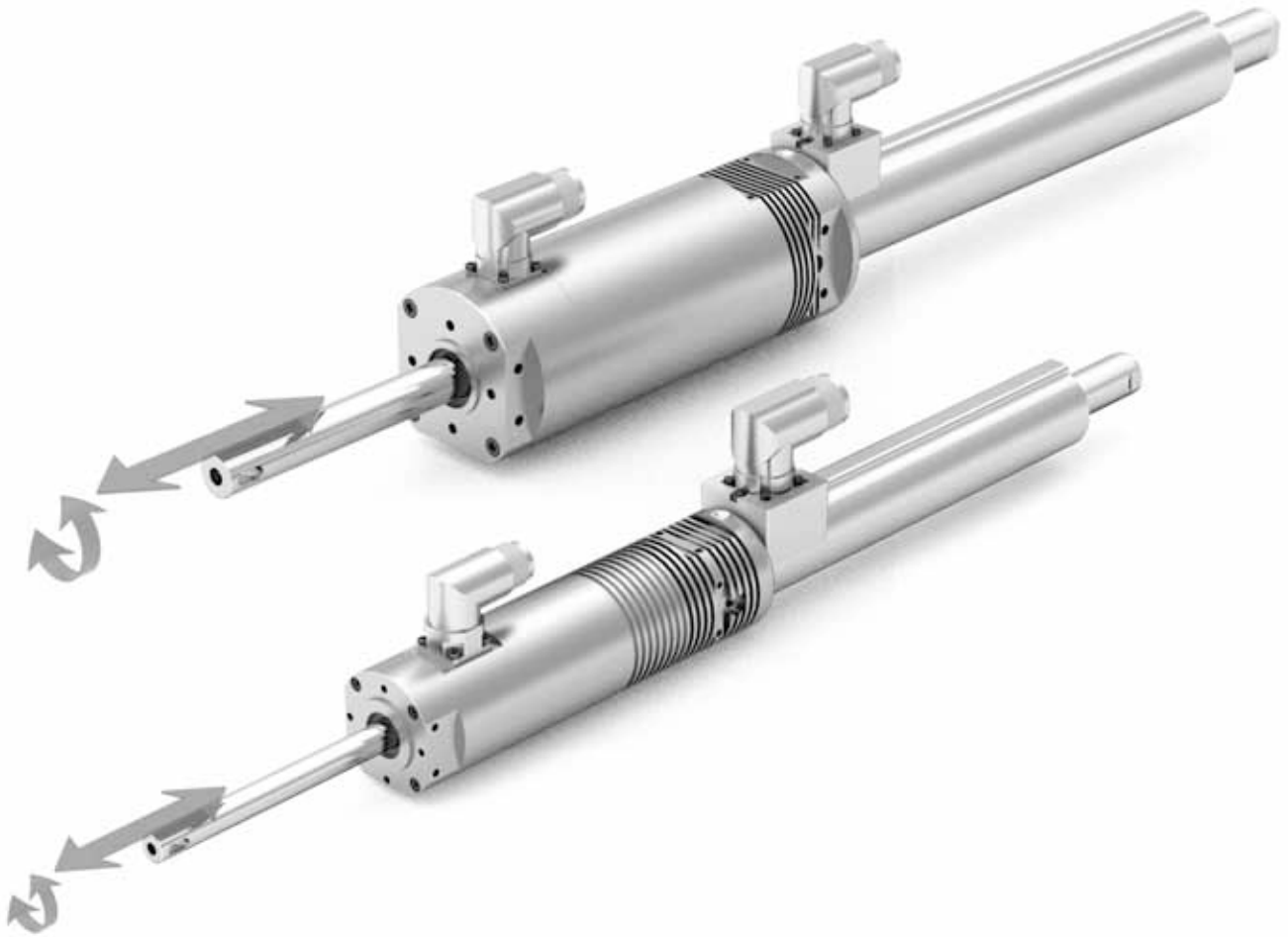

Linear and rotary direct drive



Independent linear and rotary motion



Synchronised linear and rotary motion



Programmable press force up to 1'024N



Programmable tightening torque up to 7,5Nm

The linear motor technology for industrial applications

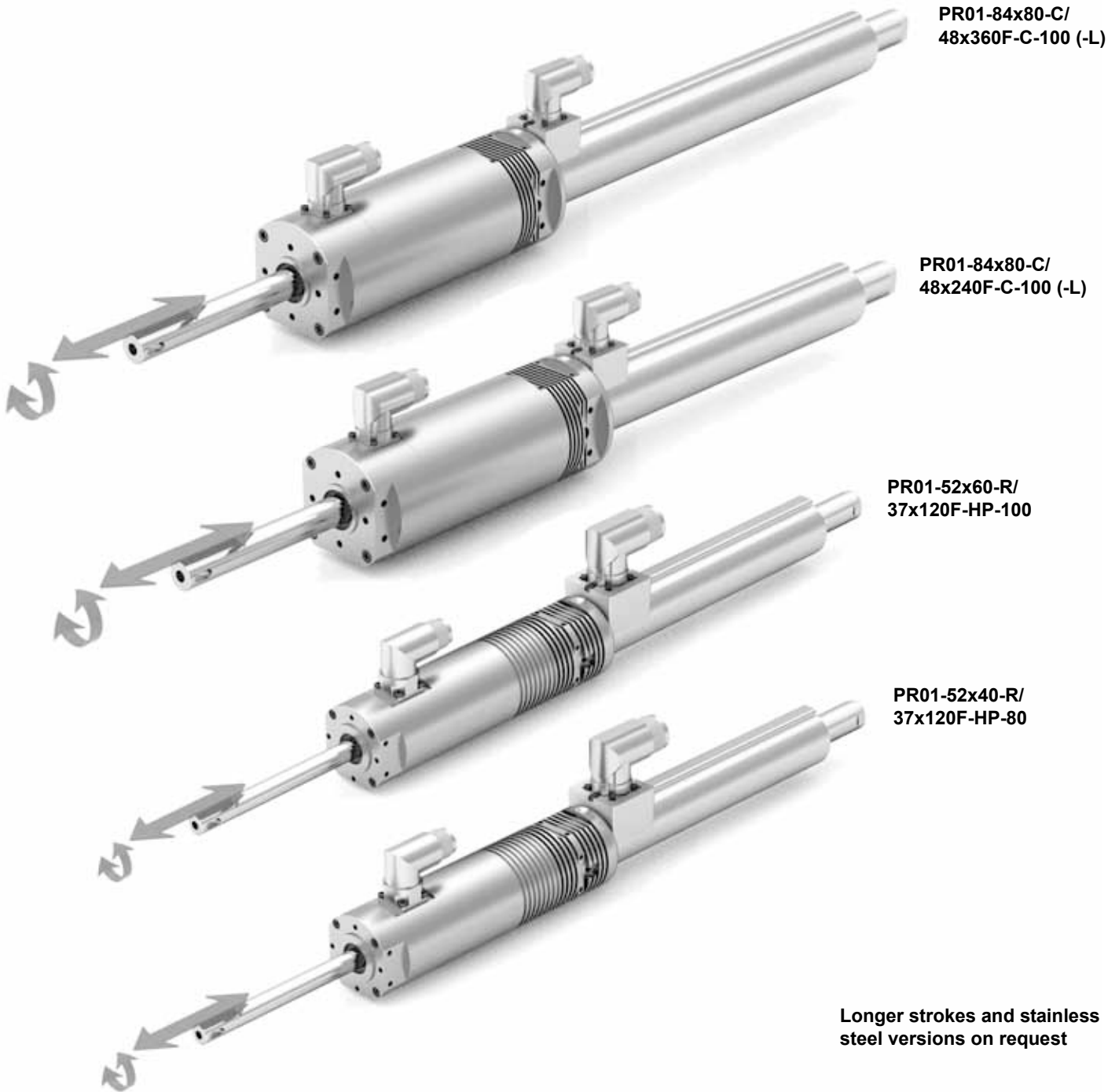

Models

Model	Stroke [mm / in]	Linear	Rotary	
		Peak Force [N / lbf]	Max. Revolutions [rpm]	Torque [Nm / lbf·in]
PR01-52x40-R/37x120F-HP-80	80 / 3.15	255 / 57.3	2000	1.4 / 12.39
PR01-52x60-R/37x120F-HP-100	100 / 3.94	255 / 57.3	1500	2 / 17.70
PR01-84x80-C/48x240F-C-100 (-L)	130 / 5.12	572 / 128.6	1000	7.5 / 66.38
PR01-84x80-C/48x360F-C-100 (-L)	130 / 5.12	1024 / 230.2	1000	7.5 / 66.38

Application Example

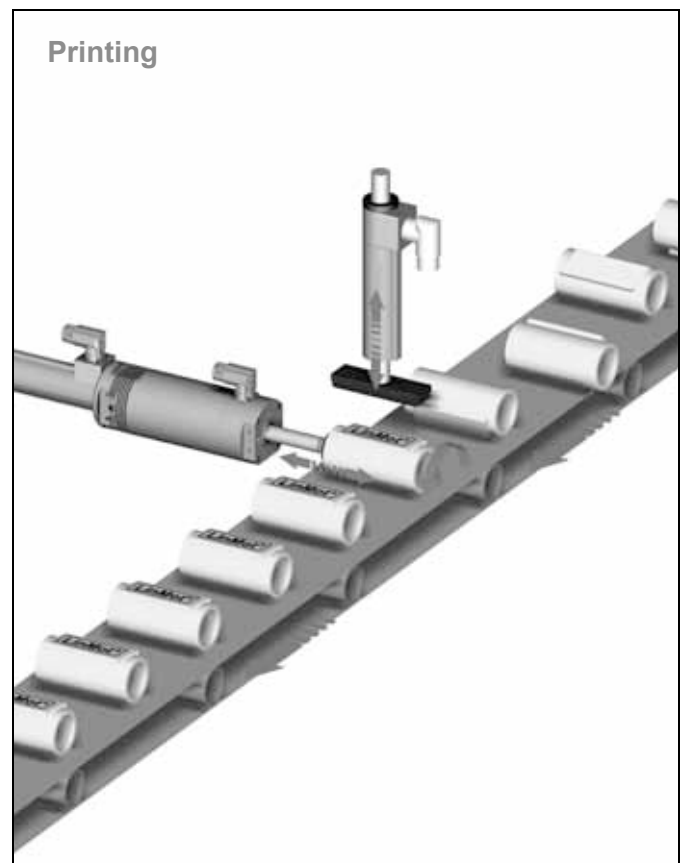
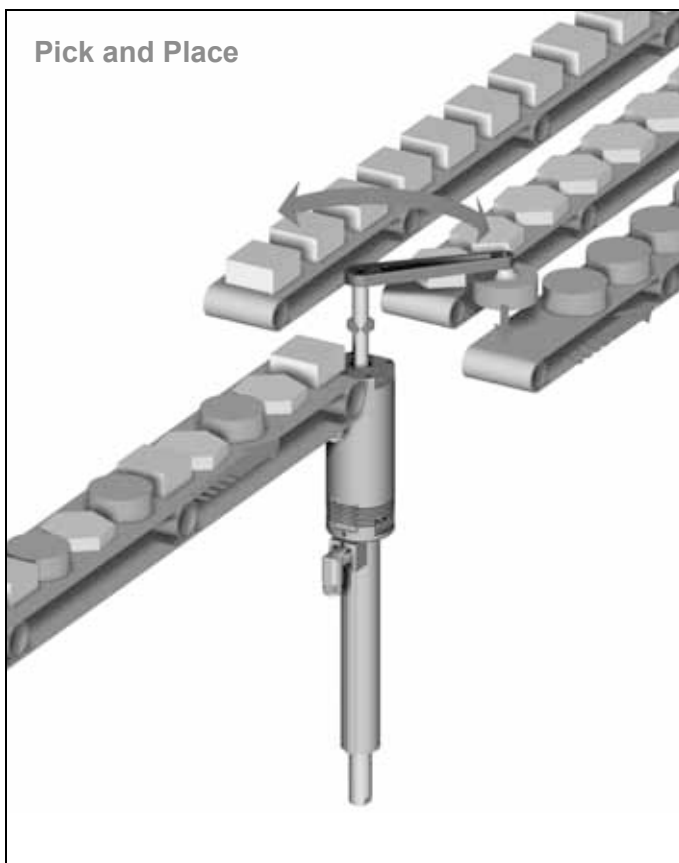
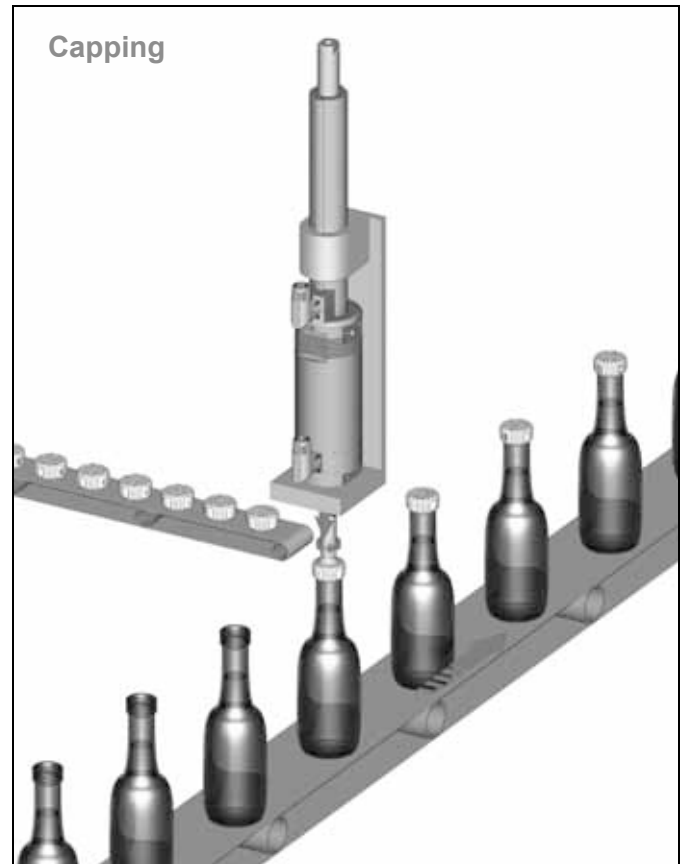
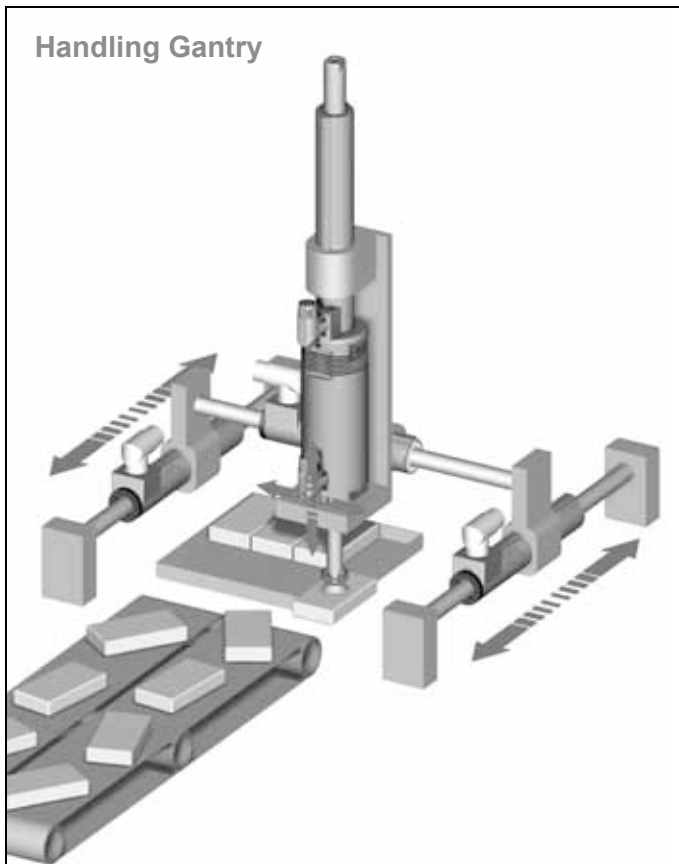

Max. Stroke: 80mm
Peak Force: 255N

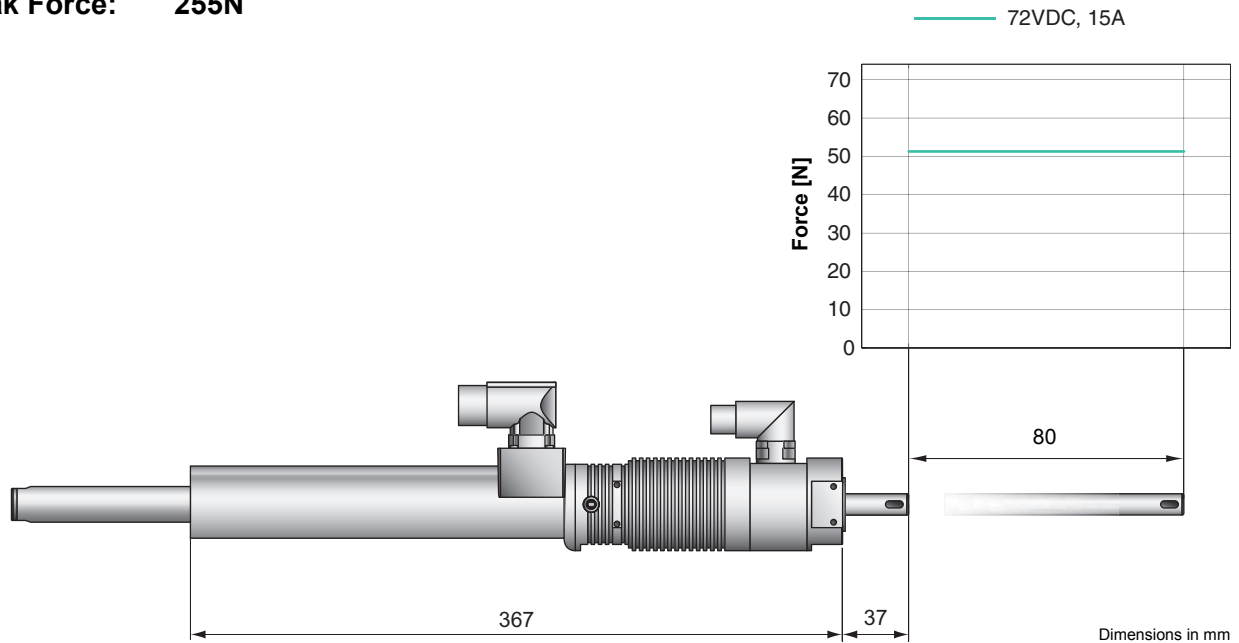

Motor Specifications

		PR01-52x40-R/37x120F-HP-C-80
Linear Motion		
Extended Stroke ES	mm (in)	80 (3.15)
Standard Stroke SS	mm (in)	80 (3.15)
Peak Force E12x0 - UC	N (lbf)	255 (57.3)
Cont. Force	N (lbf)	51 (11.5)
Cont. Force Fan cooling	N (lbf)	92 (20.7)
Force Constant	N/A (lbf/A)	17 (3.8)
Max. Current @ 72VDC	A	15
Max. Velocity @ 72VDC	m/s (in/s)	3.9 (154)
Position Repeatability	mm (in)	±0.05 (±0.0020)
Linearity	%	±0.10
Rotary Motion		
Peak Torque	Nm (lbf·in)	1.4 (12.39)
Constant Torque (Halt)	Nm (lbf·in)	0.4 (3.54)
Max. Number of revolutions	Rpm	2000
Torque Constant	Nm/A _{rms} (lbf·in/A _{rms})	0.43 (3.81)
Max. Current @ 72VDC	A _{rms}	5.7
Repeatability	°	±0.05
Mechanical Dimensions		
Overall Length	mm (in)	503 (22.48)
Diameter Linear Unit	mm (in)	37 (1.46)
Diameter Rotary Unit	mm (in)	52 (2.05)
Connection flange front	mm (in)	30 (1.18)
Mass	g (lb)	2680 (5.91)
Mass linear moved	g (lb)	790 (1.74)
Rotary Torque of inertia	kgcm ² lbf·ft ²	0.22 (0.00052)
Axle Diameter	mm (in)	12h9 (0.47h0.35)
Optional Axle with hole		no
Protection Class		IP60

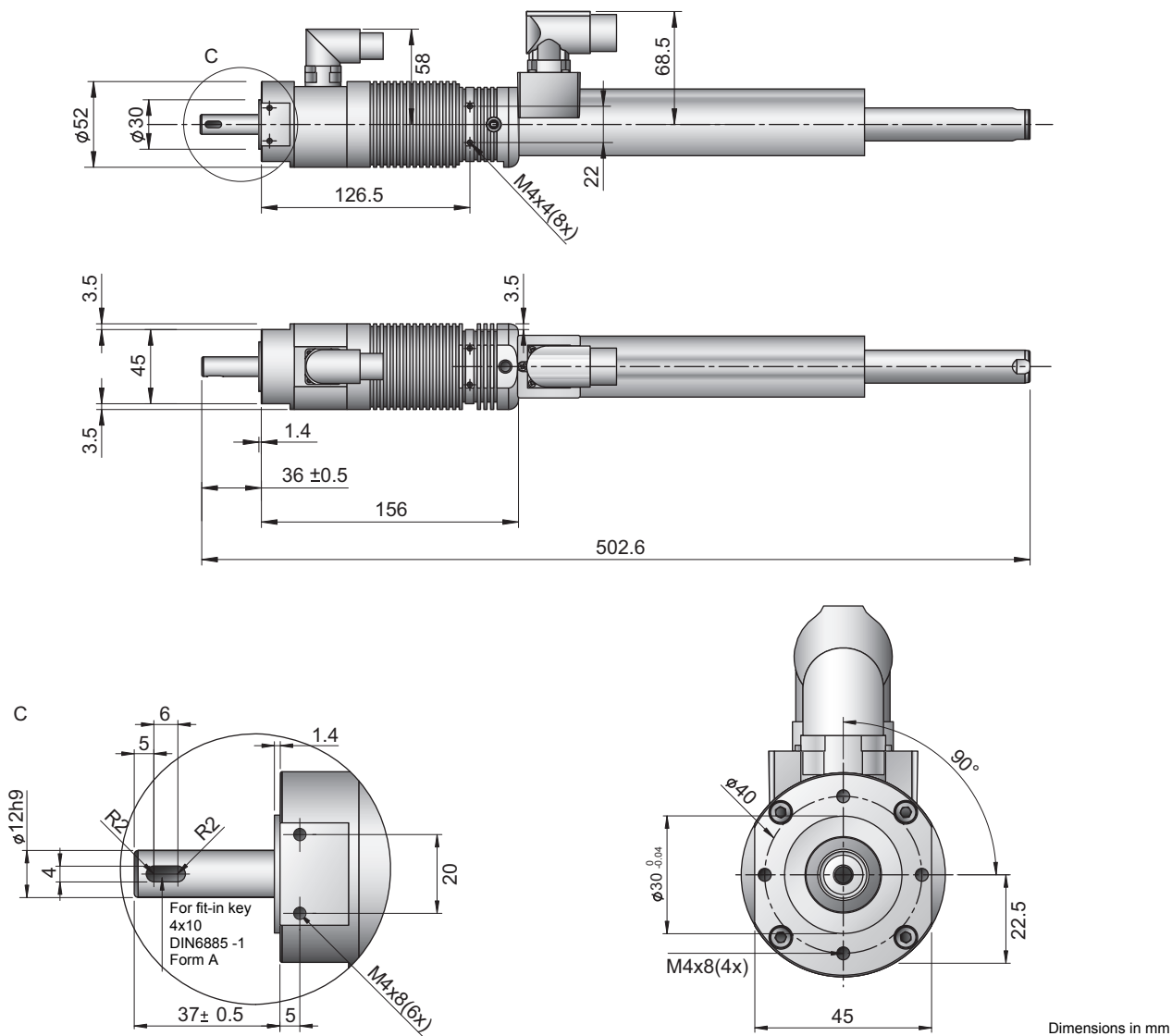

Ordering information

Item	Description	Part Number
PR01-52x40-R/37x120F-HP-C-80	Linear Rotary Motor	0150-1573

Connectors

Motor Connector Wiring		Linear Motor: C-Connector	Rotary Motor: R-Connector
Ph 1+	red	A	1
Ph 1-	pink	B	2
Ph 2+	blue	C	3
Ph 2-	gray	D	4
+5VDC	white	E	A
GND	inner Shield	F	B
Sine	yellow	G	C
Cosine	green	H	D
Temp.	black	L	E
Shield	outer Shield	Case	Case

Accessories

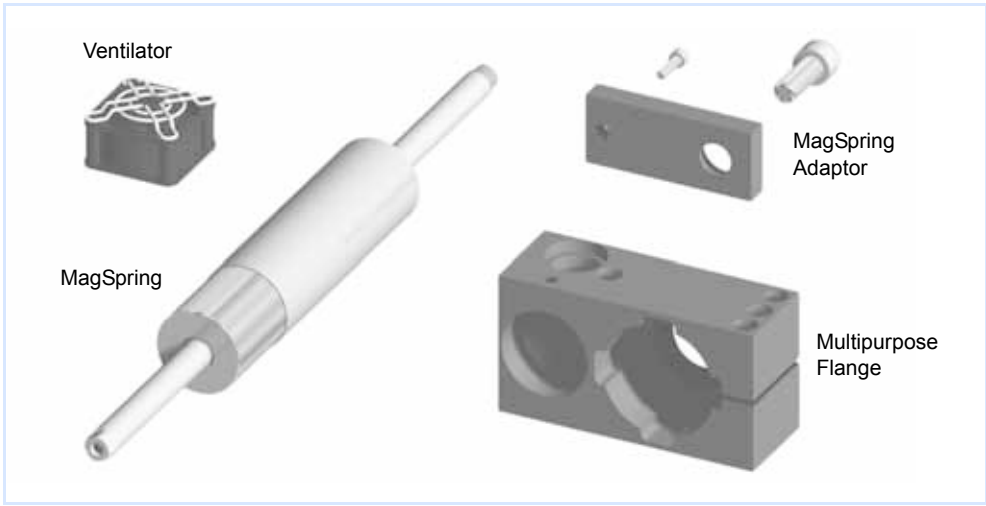

Max. Stroke: 100mm
Peak Force: 255N

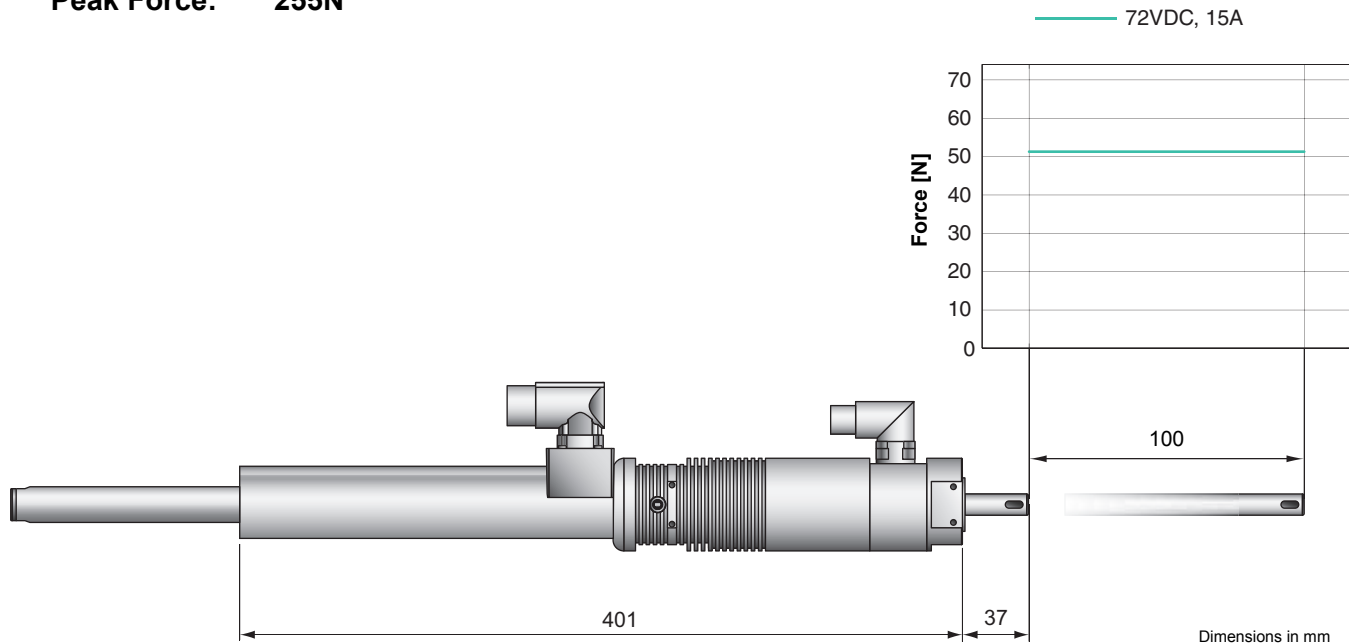

Motor Specifications

		PR01-52x60-R/37x120F-HP-C-100
Linear Motion		
Extended Stroke ES	mm (in)	100 (3.94)
Standard Stroke SS	mm (in)	100 (3.94)
Peak Force E12x0 - UC	N (lbf)	255 (57.3)
Cont. Force	N (lbf)	51 (11.5)
Cont. Force Fan cooling	N (lbf)	92 (20.7)
Force Constant	N/A (lbf/A)	17 (3.8)
Max. Current @ 72VDC	A	15
Max. Velocity @ 72VDC	m/s (in/s)	3.9 (154)
Position Repeatability	mm (in)	±0.05 (±0.0020)
Linearity	%	±0.10
Rotary Motion		
Peak Torque	Nm (lbf·in)	2 (17.7)
Constant Torque (Halt)	Nm (lbf·in)	0.5 (4.4)
Max. Number of revolutions	Rpm	1500
Torque Constant	Nm/A _{rms} (lbf·in/A _{rms})	0.46 (4.07)
Max. Current @ 72VDC	A _{rms}	6.2
Repeatability	°	±0.05
Mechanical Dimensions		
Overall Length	mm (in)	564 (22.20)
Diameter Linear Unit	mm (in)	37 (1.46)
Diameter Rotary Unit	mm (in)	52 (2.05)
Connection flange front	mm (in)	30 (1.18)
Mass	g (lb)	3120 (6.88)
Mass linear moved	g (lb)	860 (1.90)
Rotary Torque of inertia	kgcm ² lbf ²	0.26 (0.0061)
Axle Diameter	mm (in)	12h9 (0.47h0.35)
Optional Axle with hole		no
Protection Class		IP60

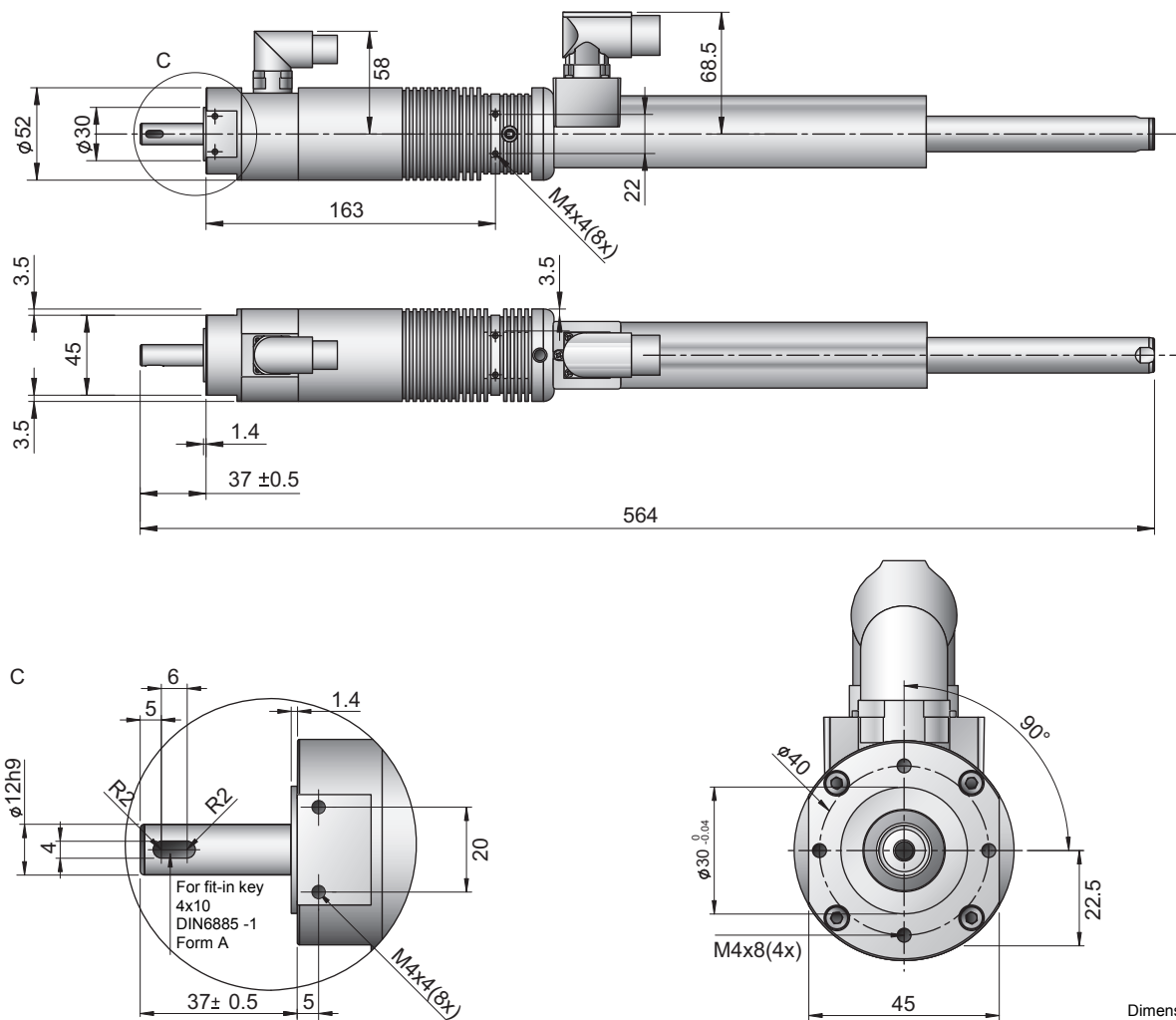

Dimensions in mm

Ordering information

Item	Description	Part Number
PR01-52x60-R/37x120F-HP-C-100	Linear Rotary Motor	0150-1197

Connectors

Motor Connector Wiring		Linear Motor: C-Connector	Rotary Motor: R-Connector
Ph 1+	red	A	1
Ph 1-	pink	B	2
Ph 2+	blue	C	3
Ph 2-	gray	D	4
+5VDC	white	E	A
GND	inner Shield	F	B
Sine	yellow	G	C
Cosine	green	H	D
Temp.	black	L	E
Shield	outer Shield	Case	Case

Accessories

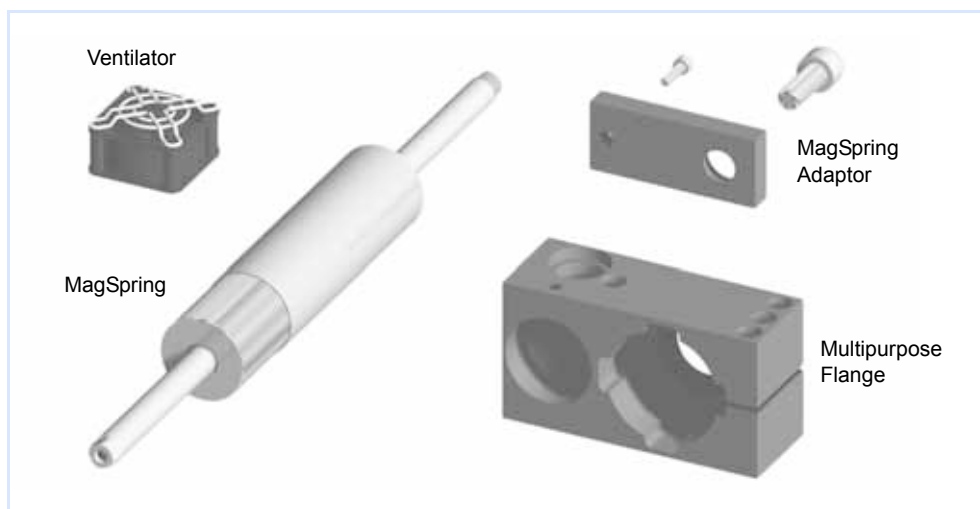

Max. Stroke: 130mm
Peak Force: 572N

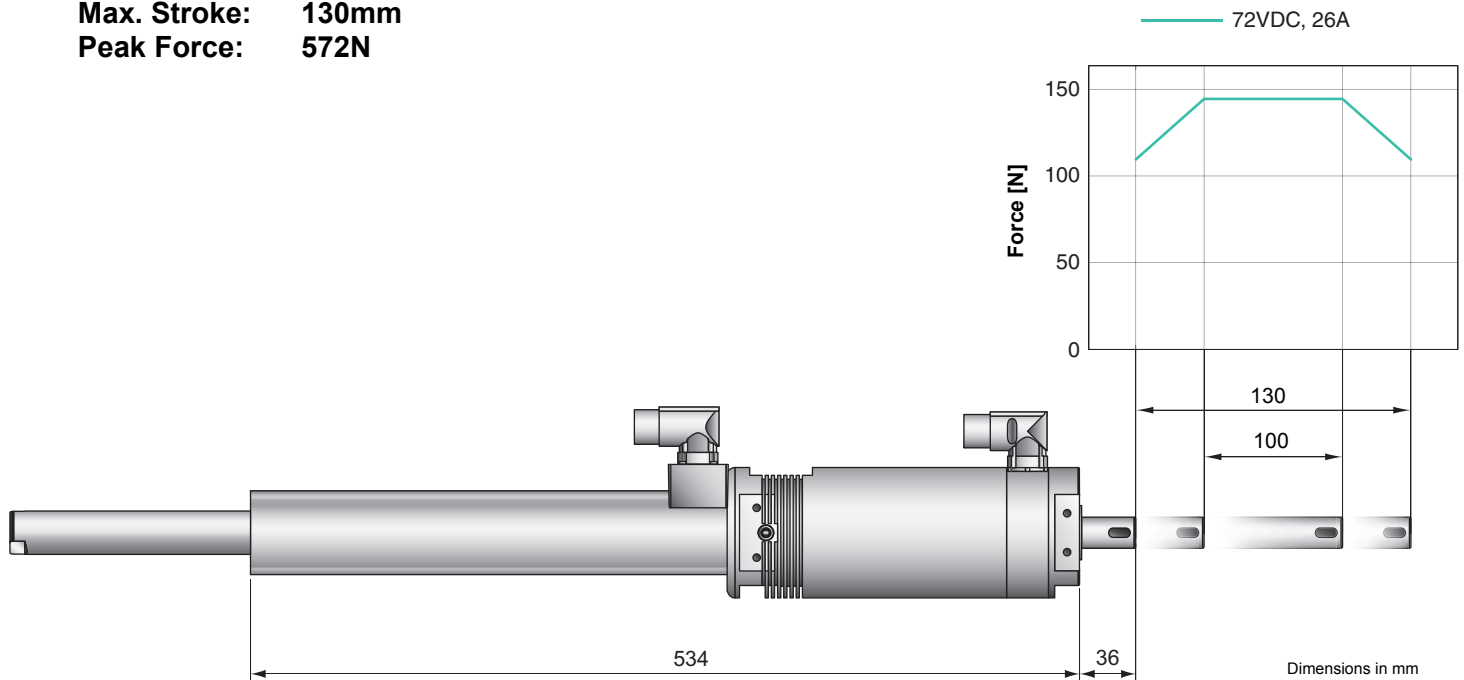

Motor Specifications

		PR01-84x80-C/48x240F-C-100 (-L)
Linear Motion		
Extended Stroke ES	mm (in)	130 (5.12)
Standard Stroke SS	mm (in)	100 (3.94)
Peak Force E12x0 - UC	N (lbf)	572 (128.6)
Cont. Force	N (lbf)	145 (74.2)
Cont. Force Fan cooling	N (lbf)	258 (58.0)
Force Constant	N/A (lbf/A)	22 (5.0)
Max. Current @ 72VDC	A	26
Max. Velocity @ 72VDC	m/s (in/s)	3.0 (118)
Position Repeatability	mm (in)	±0.05 (±0.0020)
Linearity	%	±0.15
Rotary Motion		
Peak Torque	Nm (lbf·in)	7.5 (66.4)
Constant Torque (Halt)	Nm (lbf·in)	3 (26.6)
Max. Number of revolutions	Rpm	1000
Torque Constant	Nm/A _{rms} (lbf·in/A _{rms})	0.31 (2.74)
Max. Current @ 72VDC	A _{rms}	25
Repeatability	°	±0.05
Mechanical Dimensions		
Overall Length	mm (in)	726 (28.58)
Diameter Linear Unit	mm (in)	48 (1.89)
Diameter Rotary Unit	mm (in)	84 (3.31)
Connection flange front	mm (in)	35 (1.38)
Mass	g (lb)	8850 (19.51)
Mass linear moved	g (lb)	2450 (5.40)
Rotary Torque of inertia	kgcm ² lbf ²	2.0 (0.0047)
Axle Diameter	mm (in)	20h9 (0.79h0.35)
Axle with hole		option -L
Protection Class		IP60

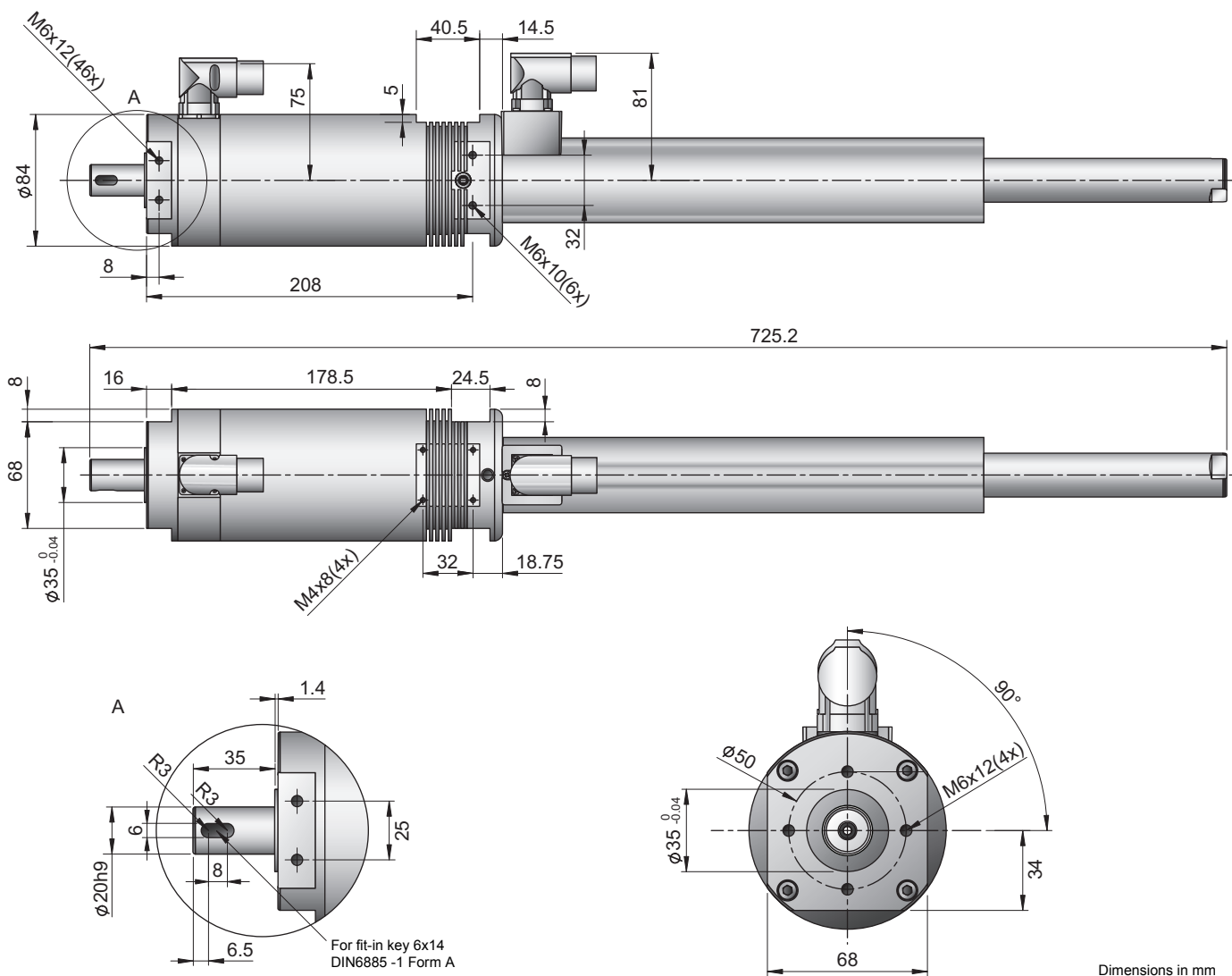

Dimensions in mm

Ordering information

Item	Description	Part Number
PR01-84x80-C/48x240F-C-100	Linear Rotary Motor	0150-1194
PR01-84x80-C/48x240F-C-100-L	Linear Rotary Motor with hollow Shaft	0150-1196

Connectors

Motor Connector Wiring		Linear Motor: C-Connector	Rotary Motor: C-Connector
Ph 1+	red	A	A
Ph 1-	pink	B	B
Ph 2+	blue	C	C
Ph 2-	gray	D	D
+5VDC	white	E	E
GND	inner Shield	F	F
Sine	yellow	G	G
Cosine	green	H	H
Temp.	black	L	L
Shield	outer Shield	Case	Case

Accessories

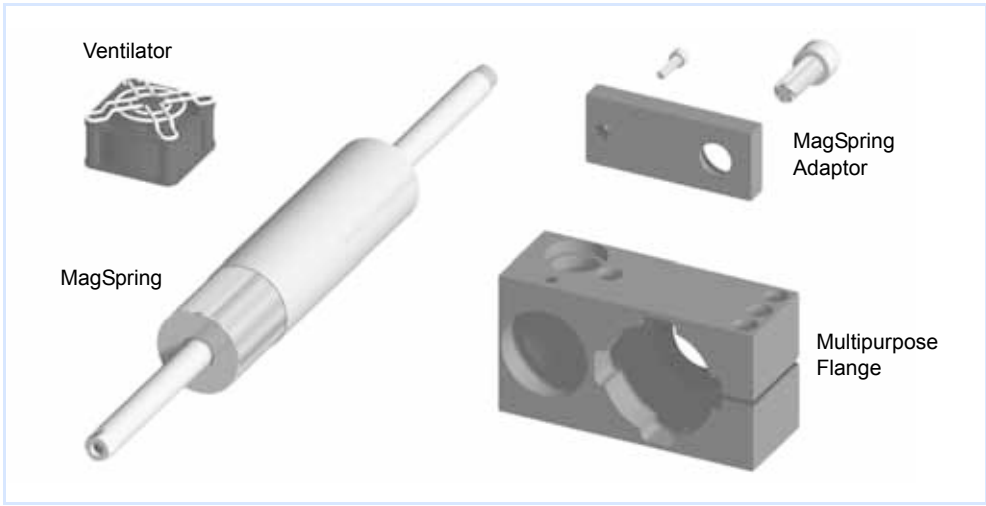

Max. Stroke: 130mm
Peak Force: 1024N

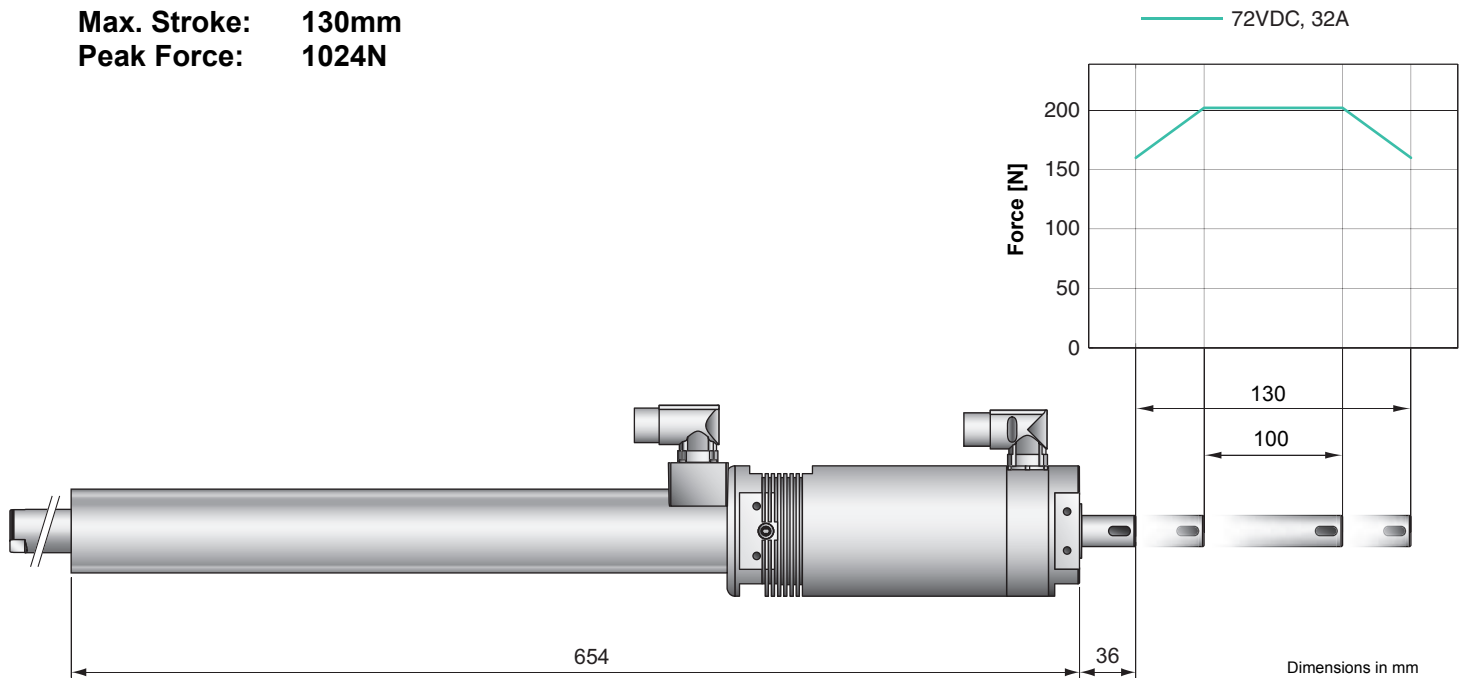

Motor Specifications

		PR01-84x80-C/48x360F-C-100 (-L)
Linear Motion		
Extended Stroke ES	mm (in)	130 (5.12)
Standard Stroke SS	mm (in)	100 (3.94)
Peak Force E12x0 - UC	N (lbf)	1024 (230.2)
Cont. Force	N (lbf)	203 (45.6)
Cont. Force Fan cooling	N (lbf)	354 (79.6)
Force Constant	N/A (lbf/A)	22 (4.9)
Max. Current @ 72VDC	A	32
Max. Velocity @ 72VDC	m/s (in/s)	2.1 (83)
Position Repeatability	mm (in)	±0.05 (±0.0020)
Linearity	%	±0.15
Rotary Motion		
Peak Torque	Nm (lbf·in)	7.5 (66.4)
Constant Torque (Halt)	Nm (lbf·in)	3 (26.6)
Max. Number of revolutions	Rpm	1000
Torque Constant	Nm/A _{rms} (lbf·in/A _{rms})	0.31 (2.74)
Max. Current @ 72VDC	A _{rms}	25
Repeatability	°	±0.05
Mechanical Dimensions		
Overall Length	mm (in)	849 (33.43)
Diameter Linear Unit	mm (in)	48 (1.89)
Diameter Rotary Unit	mm (in)	84 (3.31)
Connection flange front	mm (in)	35 (1.38)
Mass	g (lb)	10480 (23.10)
Mass linear moved	g (lb)	2900 (6.39)
Rotary Torque of inertia	kgcm ² lbf·ft ²	2.0 (0.0047)
Axle Diameter	mm (in)	20h9 (0.79h0.35)
Axle with hole		option -L
Protection Class		IP60

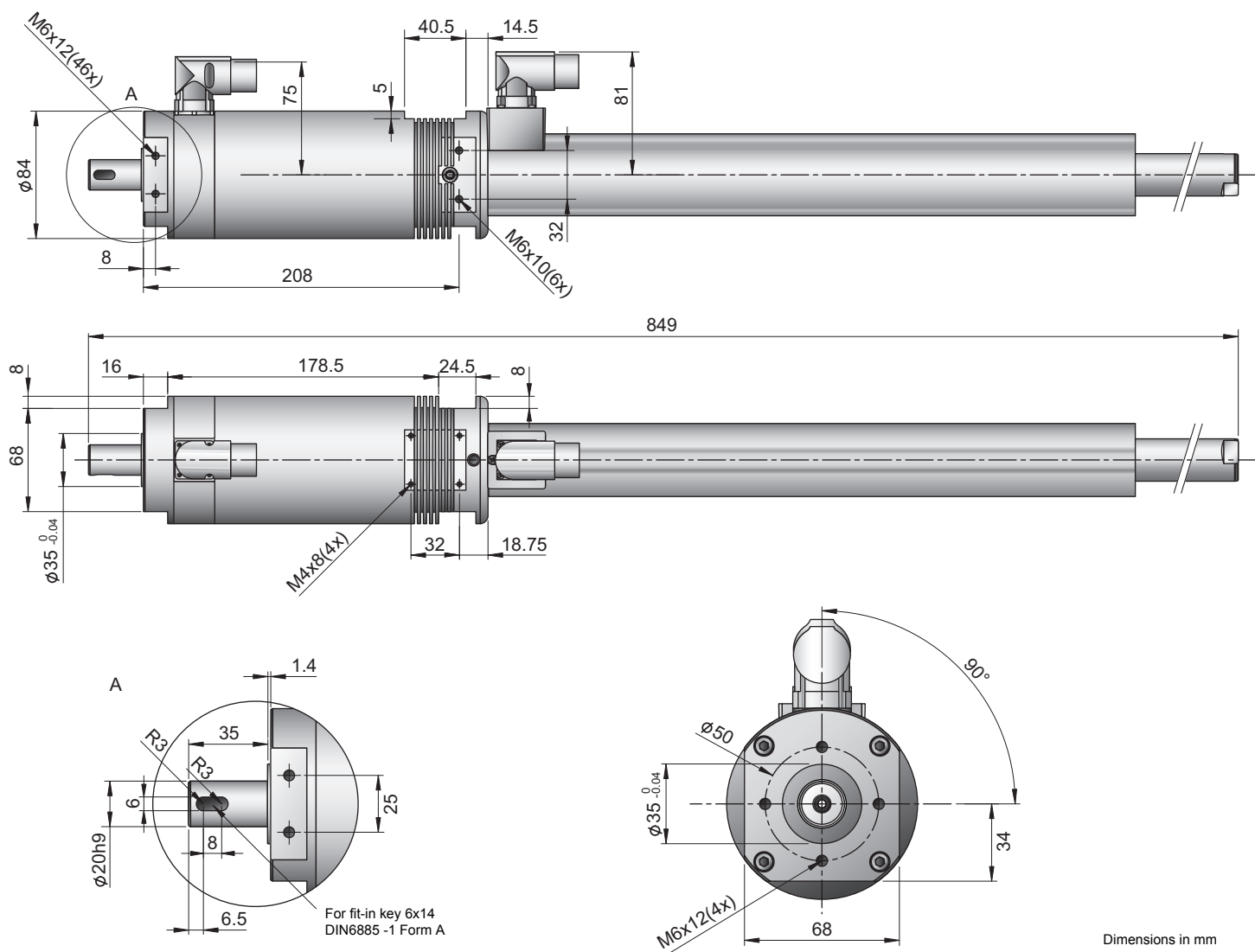

Dimensions in mm

Ordering information

Item	Description	Part Number
PR01-84x80-C/48x360F-C-100	Linear Rotary Motor	0150-1199
PR01-84x80-C/48x360F-C-100-L	Linear Rotary Motor with hollow Shaft	0150-1200

Connectors

Motor Connector Wiring		Linear Motor: C-Connector	Rotary Motor: C-Connector
Ph 1+ / A	red	A	A
Ph 1- / B	pink	B	B
Ph 2+ / C	blue	C	C
Ph 2- / NC	gray	D	D
+5VDC	white	E	E
GND	inner Shield	F	F
Sine	yellow	G	G
Cosine	green	H	H
Temp.	black	L	L
Shield	outer Shield	Case	Case

Accessories

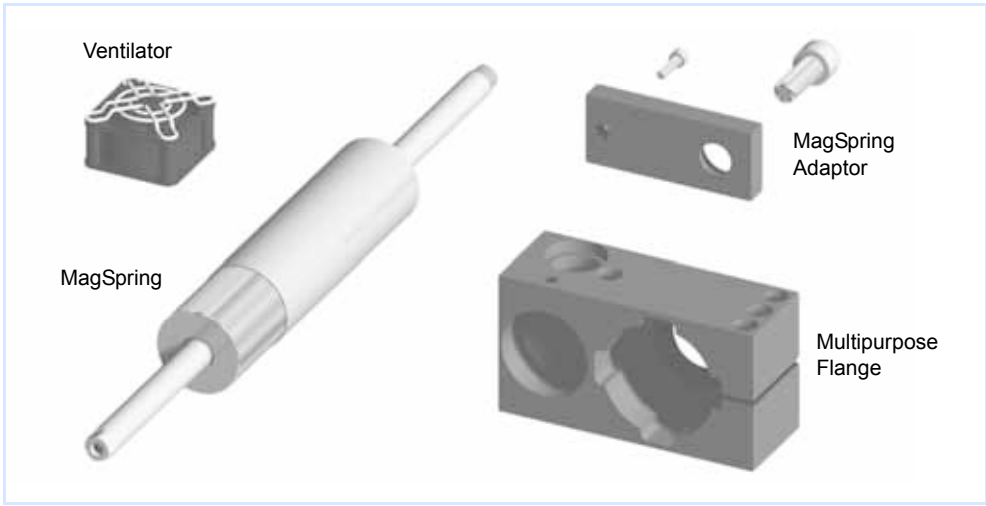

Parts

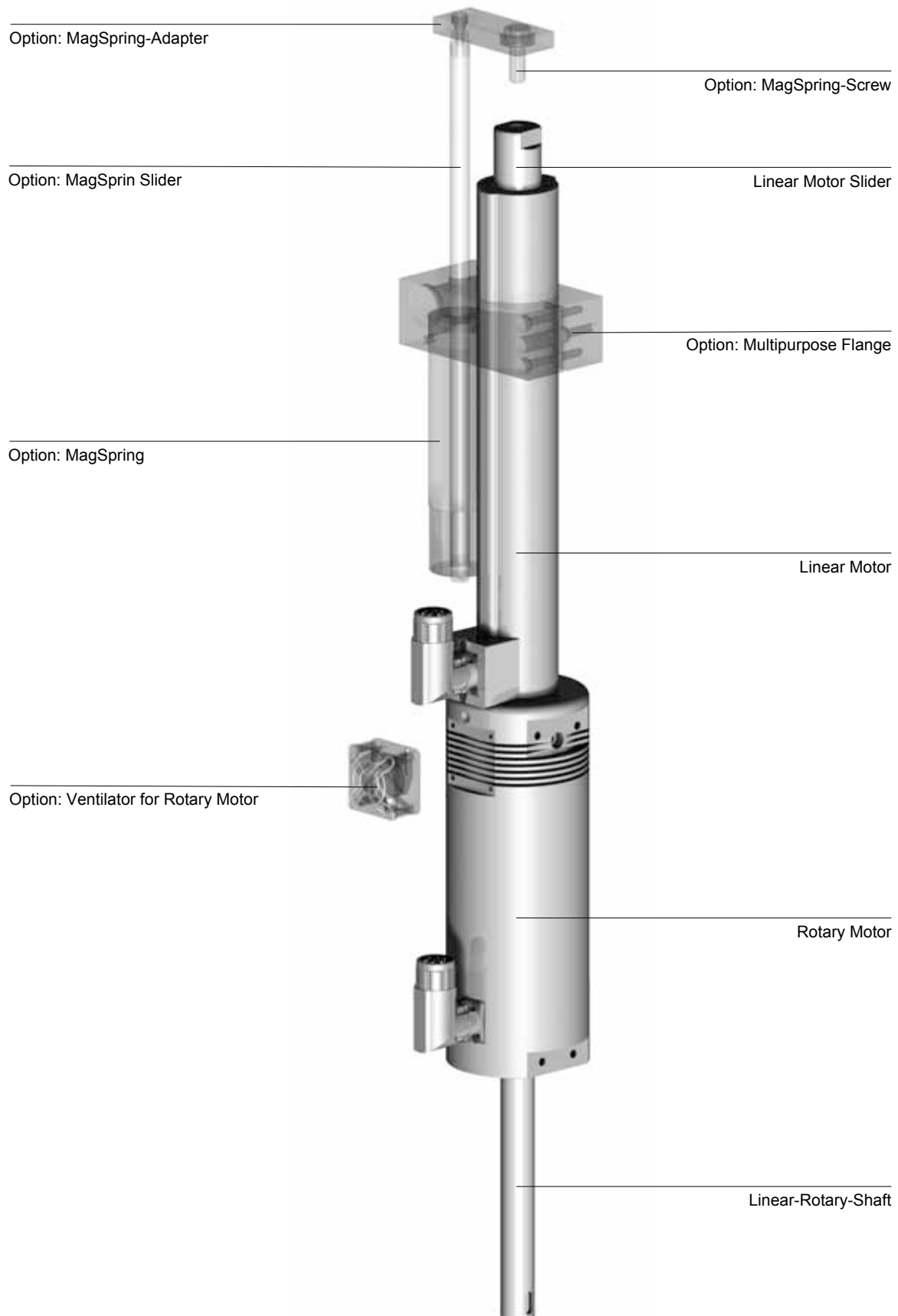

Optional cooling element for PS01-37

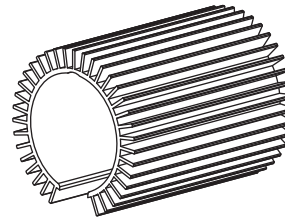
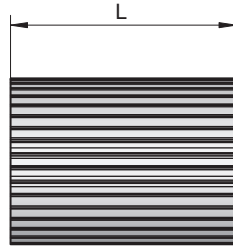
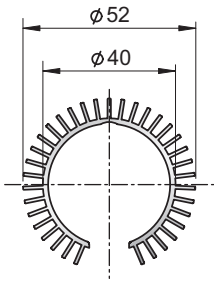

Material: Aluminum (AlMgSi)

Dimensions in mm

Item	Description	L [mm]	Weight [g]	Part Number
PC01-37x68	Cooling Element	68	70	0160-2131

Optional cooling element for PS01-48

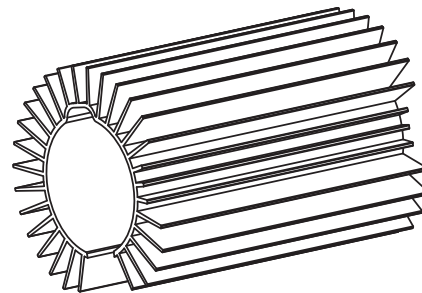
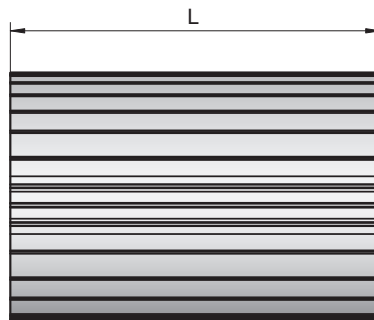
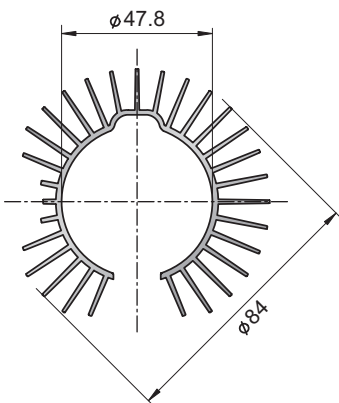

Material: Aluminum (AlMgSi)

Dimensions in mm

Item	Description	L [mm]	Weight [g]	Part Number
PC01-48x100	Cooling Element	99	208	0160-2145
PC01-48x117	Cooling Element	117	247	0160-2138

Optional wipers for linear motorparts

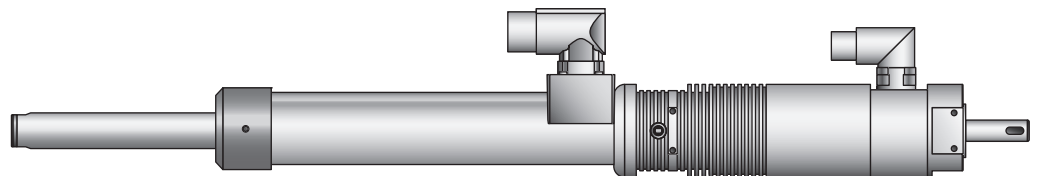
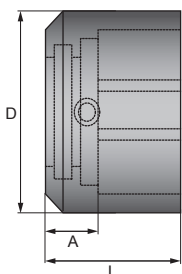

Item	D	L	A	Weight
PA01-37	45mm (1.77in)	32mm (1.26in)	12mm (0.47in)	0.028kg
PA01-48	58mm (2.28in)	32mm (1.26in)	14mm (0.55in)	0.056kg

Item	Description	Part Number
PA01-37/20-F	Wiper for PS01-37x... (front wiper)	0150-3126
PA01-48/28-F	Wiper for PS01-48x... (front wiper)	0150-3127

Optional ventilator for rotational motor RS01-52x60-R

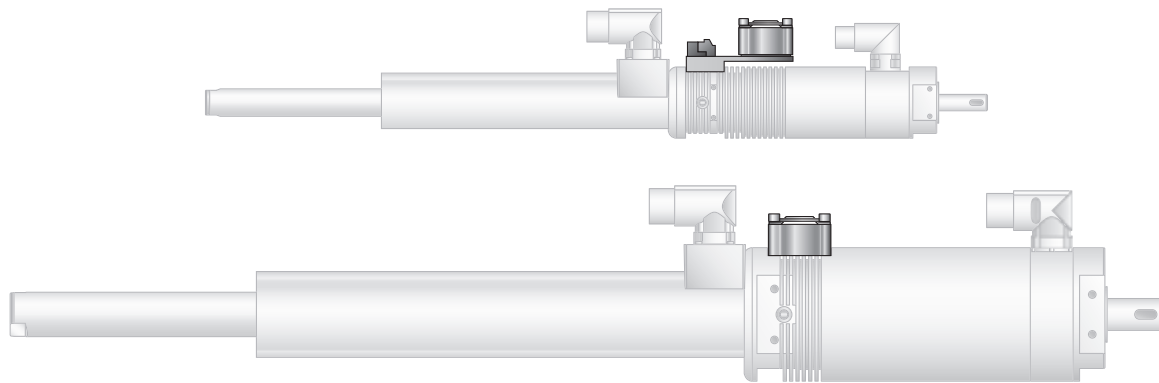

Item	Description	Weight [g]	Part Number
RS01-VA70x40-Kit	Ventilator for rotational motor RS01-52x60-R	75	0150-1599
RS01-VA84	Ventilator for rotational motor RS01-84x80-C	30	0150-1600

Adaptor for MagSpring M01-37 and Guides H01-37 / B01-37

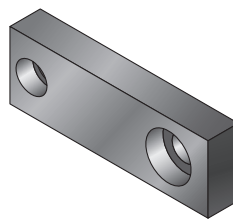
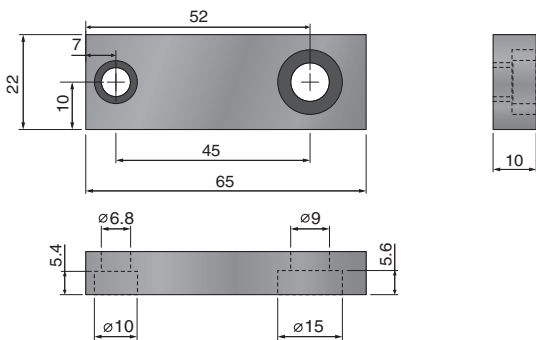

MA01-PR01-52x40-37

Material: Aluminum (AlMgSi), black anodized
Mass: approx. 34g (0.075lb)

Dimensions in mm

Item	Description	Part Number
MA01-PR01-52x40-37	Adaptor for PR01-52x60-R/37x120F-HP-C-100	0250-0121
MA01-PR01-70x40-37	Adaptor for PR01-84x80-C/48x240F-C-100	0250-0120
MA01-PR01-70x40-37-L	Adaptor for PR01-84x80-C/48x240F-C-100-L	0250-0124

Shaft Clamping Set

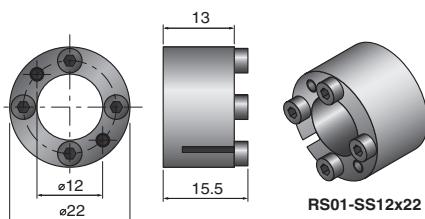

RS01-SS12x22

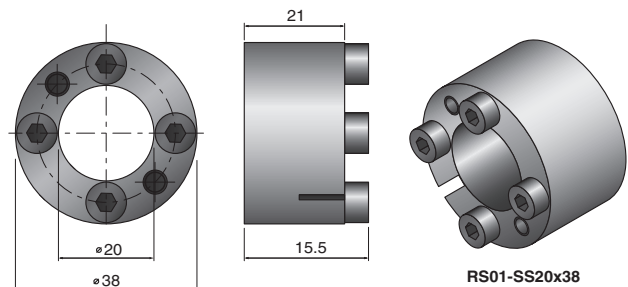

RS01-SS20x38

Material: Aluminum (AlMgSi), black anodized
Mass: RS01-SS12x22 approx. 22g (0.049lb)
RS01-SS20x38 approx. 100g (0.220lb)

Dimensions in mm

Item	Description	Part Number
RS01-SS12x22	Shaft Clamping Set for PR01-52x60-R/37x120F-HPC-100	0230-0101
RS01-SS20x38	Shaft Clamping Set PR01-84x80-C/48x240F-C-100	0230-0100

Optional multiflange and MagSpring

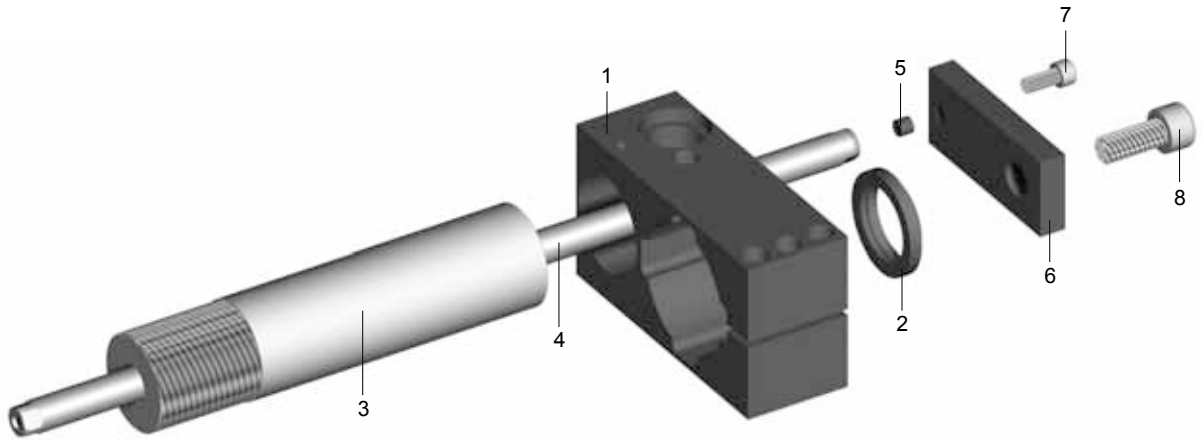

	PR01-52x40-R/37x120F-HP-C-80 PR01-52x60-R/37x120F-HP-C-100		PR01-84x80-C/48x240F-C-100 PR01-84x80-C/48x360F-C-100		PR01-84x80-C/48x240F-C-100-L PR01-84x80-C/48x360F-C-100-L	
	Item	Part Number	Item	Part Number	Item	Part Number
1 Multiflange	MF01-PR01-52x40-37	0250-2319	MF01-PR01-70x40-37	0250-2318	MF01-PR01-70x40-37	0250-2318
2 Wiperseal	PAW01-20 (delivered with Pos 1)	0150-3112	PAW01-28 (delivered with Pos 6)	0150-3133	PAW01-28 (delivered with Pos 6)	0150-3133
3 MagSpring Stator	MS01-37x155	0250-2204	MS01-37x155	0250-2204	MS01-37x155	0250-2204
4 MagSpring Slider	40N ML01-12x350/160-10	0250-2333	ML01-12x350/160-10	0250-2333	ML01-12x350/160-10	0250-2333
	60N ML01-12x335/160-20	0250-2320	ML01-12x350/160-20	0250-2321	ML01-12x350/160-20	0250-2321
5 Distance tube	MA01-PR01-Huelse 4,9 (delivered with Pos 6)	0250-0123	MA01-PR01-Huelse 4,9 (delivered with Pos 6)	0250-0123	MA01-PR01-Huelse 4,9 (delivered with Pos 6)	0250-0123
6 MagSpring Adaptor	MA01-PR01-52x40-37	0250-0121	MA01-PR01-70x40-37	0250-0120	MA01-PR01-70x40-37-L	0250-0124
7 Hexagon Socket	Socket M5x14 (delivered with Pos 6)		Socket M5x14 (delivered with Pos 6)		Socket M5x14 (delivered with Pos 6)	
8 Hexagon Socket or coupling device	Socket M8x14 (delivered with Pos 6)		Socket M10x14 (delivered with Pos 6)		Socket or coupling device (delivered with Pos 6)	

Multipurpose Flanges

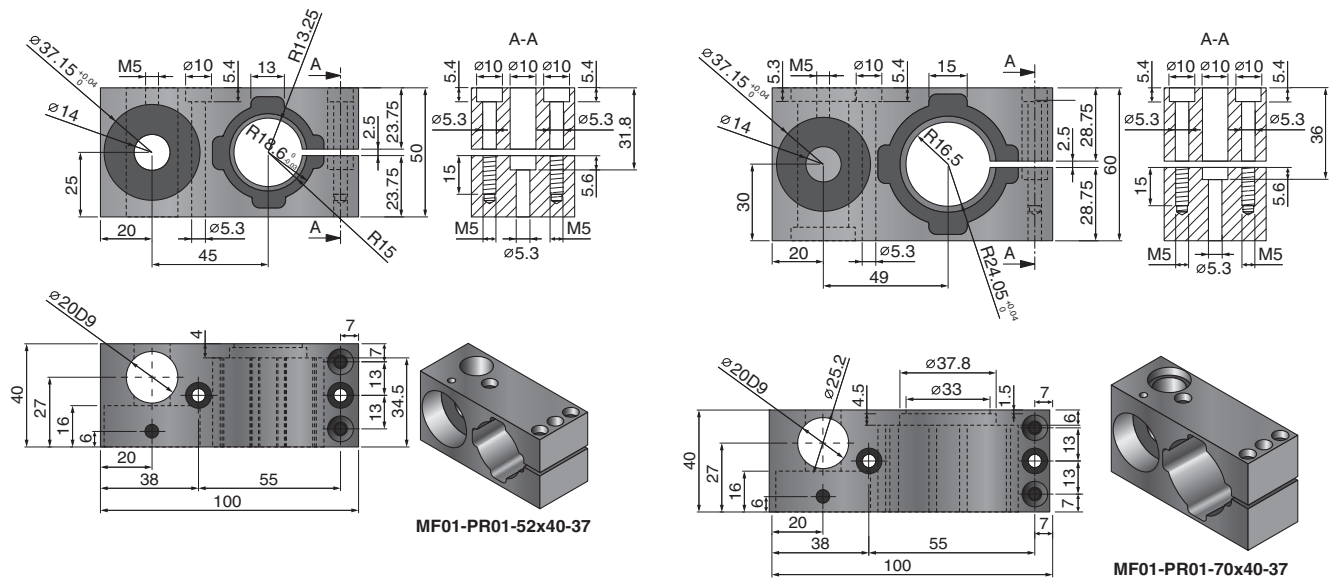

Material: Aluminum (AlMgSi), black anodized
 Mass: MF01-20/H23 approx. 310g (0.683lb)
 MF01-20/H37 approx. 390g (0.860lb)

Dimensions in mm

Item	Description	Part Number
MF01-PR01-52x40-37	Multipurpose Flange for PR01-52x60-R/37x120F-HP-C-100	0250-2319
MF01-PR01-70x40-37	Multipurpose Flange for PR01-84x80-C/48x240F-C-100	0250-2318

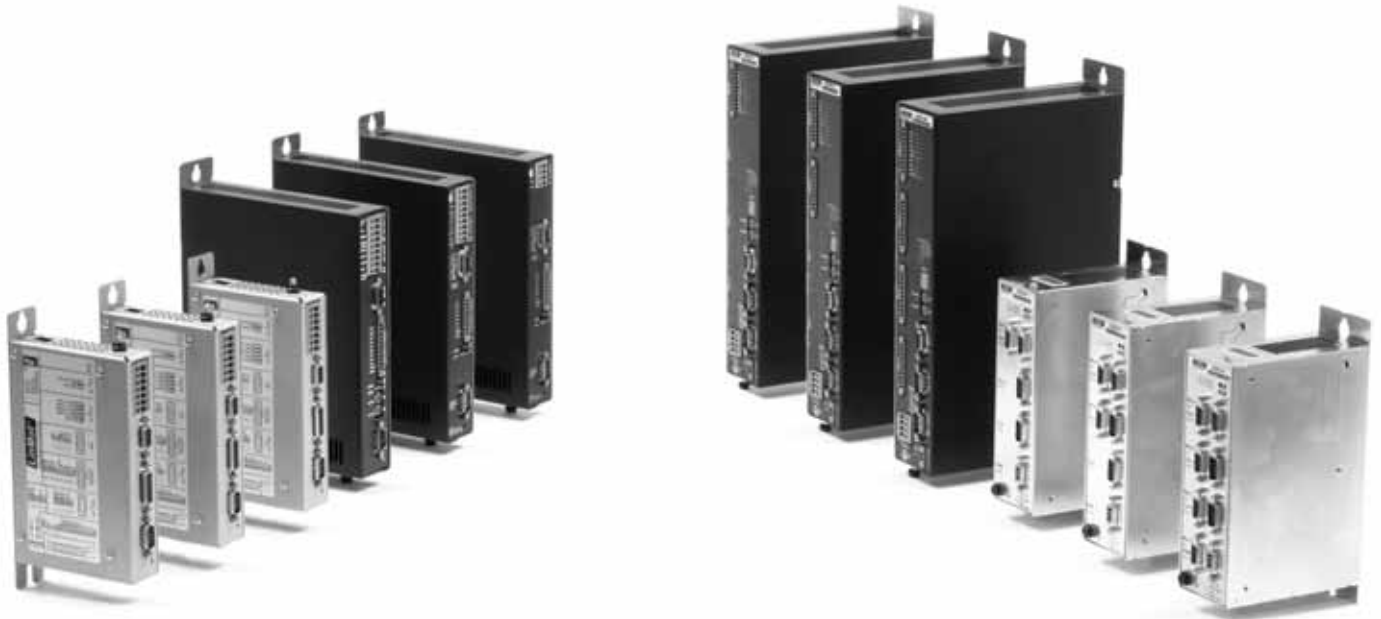

LinMot Servo Drives 316

Servo Drives E100/E1001 323

Servo Drive E1100 347

Servo Drive E1200 371

Servo Drive C1200 387

Servo Drive B1100 403

Multi-Axes System B1150 / 8050 423

LinMot Servo Drives

LinMot linear motors, together with the associated Servo Drives, create an optimal drive system for linear positioning tasks. The wide range of drive products allows rapid implementation of simple applications with two end positions, up to complex, high-precision multi-axis applications with synchronization to a main electronic shaft.



Simple Integration

Connection to an overlaid control system can be made via analog, digital, or serial interfaces, fieldbuses, or ETHERNET. The wide range of fieldbus interfaces and protocols allows simple integration of LinMot Servo Drives in any controls concept. Regardless of the manufacturer and type of controls, LinMot Servo Drives provide the right interface to connect to an overlaid PLC, industrial PC, or proprietary control system.



Intelligence right in the drive

LinMot Servo Drives are highly integrated inverters with one or more power elements, for controlling the motors, and an intelligent control element with integrated position regulation. The control element performs all drive-related control and monitoring functions. It allows direct position set points, or travel along internally stored motion profiles from the overlaid control, using simple analog or digital signals.

Simplest Applications

Because of their high dynamic capabilities, long life, and ability to travel to several positions, LinMot linear motors are often used as a replacement for pneumatic cylinders.

Various end positions can be stored in the drive and are invoked via digital signals, just as with a pneumatic cylinder. Once the end position is reached, this is reported to the overlaid control via the In-position signal on a digital output. Speed and acceleration can be configured freely for each motion.

Standard Applications

With control via fieldbuses or an Ethernet interface, standard applications can be implemented with simple point-to-point motions. Position, speed, and acceleration can be configured freely, and are provided via the bus.

Complicated or co-dependent motions can be stored on the drive in the form of travel profiles, and started via digital trigger signals or the bus connection.

High-End Applications

Complex applications with synchronization to a main or master shaft can be implemented without trouble using the integrated master encoder interface.

Travel along paths from an overlaid NC drive can be implemented via the +/-10V interface, or in streaming mode (PVT, PV).

Together with a high-resolution, external position sensor, even high-precision positioning tasks in µm range can be handled.

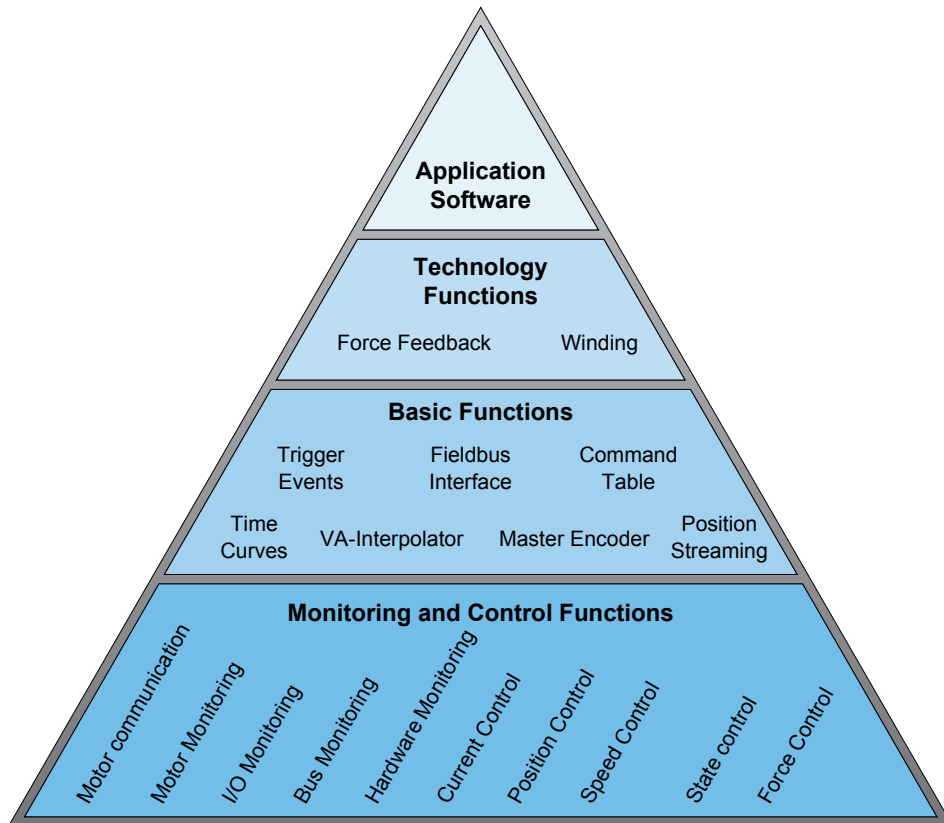

Application Software

Using a software application, customer-specific applications can be programmed directly in the drive. This is mainly an advantage when very fast sequences need to be implemented, for which the communication speed or computing power of the overlaid control are not sufficient.

Technology Functions

Technology functions are generally available functional blocks that provide a complete solution for standard applications. The technology function can take over complete sequence control of a process. With the technology function "winding textile yarns", only a few parameters are provided by the overlaid control, such as the number of windings. The complete winding process then takes place automatically.

Basic Functions

The basic functions include communication with the overlaid control, generation of target values for speed and acceleration-limited point-to-point motions, travel along motion profiles, synchronization of drives to an electronic main or master shaft, and synchronization in multi-axis applications.

Monitoring and Control

The basic functions of the Servo Drive, such as position and current control; control and monitoring of the power element; and monitoring the motor temperature, power, and position are handled by the control, monitoring, and regulation element, which also controls the entire finite state machine of the drive.

Modular Firmware

LinMot Servo Drives are used as pure position drives. Additionally, using the technology functions or a customer-specific software application, complete sequences or functions can be implemented for customerspecific applications.

Multi-axis operation

In multi-axes or linked operation, the master encoder interface can control both individually and synchronous to a main or master shaft.

For complex designs, several axes can be synchronized in master-booster or master-gantry mode. This allows simple implementation of portal designs with two synchronized axes, which are controlled by the overlaid control as a single axis.

Linear and Rotary Drives

Using Series E1100 / B1100 Servo Drives, rotary servomotors can be used as well as linear motors, or any 1/2/3-phase actuators.

Primarily in assembly automation and feeding applications, small, light brushless DC motors (EC motors) are often needed to rotate a gripper about the Z-axis. The flexibility of the Servo Drive allows such rotary motors to be integrated into the existing controls concept in the same simple manner as linear motors.

Certified Safety

The safe impulse block on the Series E1100 Servo Drive allows safety concepts to be implemented in machines and system with minimum effort and additional external components.

Safety Standard EN954-1

Servo Drive Series E100/E1001

Servo controls from the Series E100 and E1001 are one, two, or four-axis drives with 16-bit position resolution.

The drives are suitable for simple and standard positioning tasks in the low to medium force range, in which linear motors are operated without optional peripherals such as reference and end stop switches, external high-precision position sensors, or a holding brake.

Connection to the overlaid control is done via analog and digital signals, a serial connection, and fieldbuses.

The compact size is a great advantage of the Series E100/E1001 Servo Drives, primarily for compound and multi-axis applications, with regard to installation space and effort.

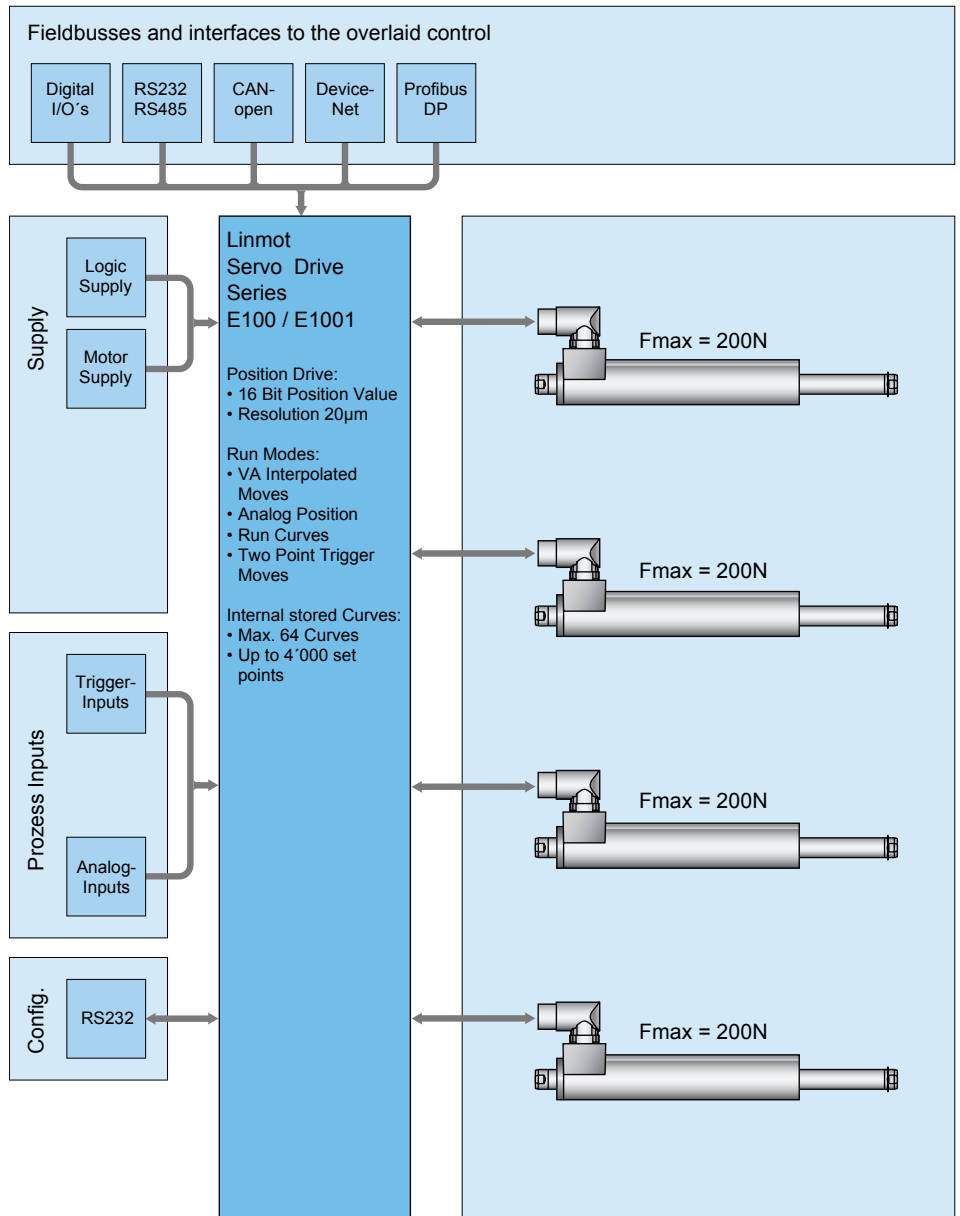

Servo Drive Series E100

Single and multiple axes drives for standard positioning tasks.

- Analog, digital, and industrial fieldbus interfaces
- For low forces
- For standard precision
- 16-Bit position resolution for short and medium stroke ranges
- Point to point motions and travel along setpoint curves
- Electronic cam disc (Option)
- Master gantry and master booster synchronization
- Control of LinMot linear motors

Servo Drive Series E1001

Single and multiple axes drive for standard positioning tasks.

- Analog, digital, and industrial fieldbus interfaces
- For low and medium forces
- For standard precision
- 16-Bit position resolution for short and medium stroke ranges
- Point to point motions and travel along setpoint curves
- Master gantry and master booster synchronization
- Control of LinMot linear motors

Servo Drives E400 in use

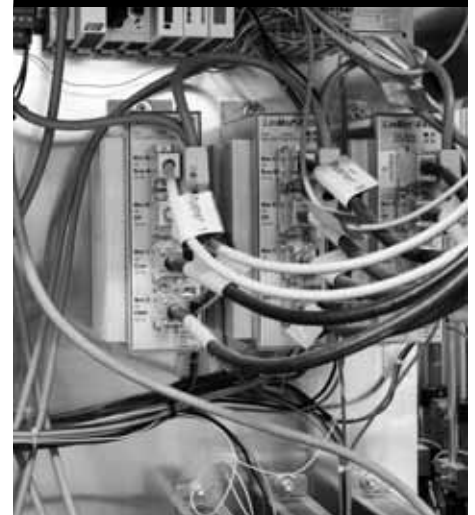

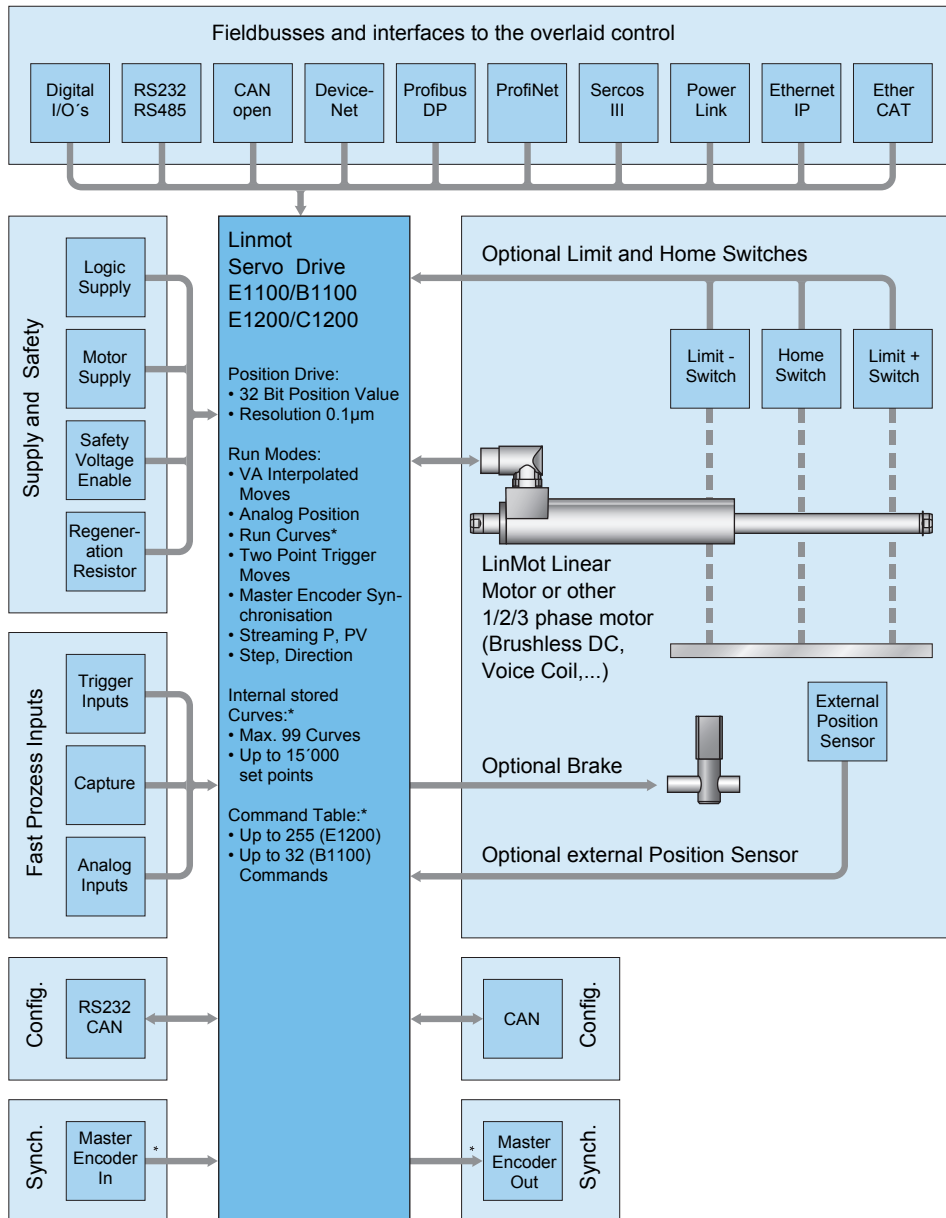

Servo Drive Series E1100/B1100 Series E1200/C1200

LinMot Servo Drives are modular axis drives with 32-bit position resolution for linear motors and rotary drives.

The drives are suitable for simplest, standard, and high-end positioning tasks, across the entire force range of the LinMot product range. Flexible hardware enables control of any 1/2/3-phase motors. Thus, low-power rotary servomotors, such as brushless DC motors, can be integrated in the same controls concept.

Additionally, the drives can be equipped with optional peripherals, such as reference and end stop switches, high-precision external position sensors, and holding brakes.

LinMot Servo Drives have analog and digital inputs and outputs, serial interfaces, fieldbuses, and ETHERNET connections. The user is therefore not dependent on the selection of the overlaid control. An appropriate interface is available, with associated protocols, for any PLC or IPC solution.

With flexibility and a compact form factor, LinMot Servo Drives provide a complete solution for a flexible drive concept in single and multiple axis applications, with linear motors and other actuators.

Servo Drive Series E1100

Single-axis drive for simplest, standard, and high-end positioning tasks.

- Analog, digital, and industrial fieldbus interfaces, as well as industrial ETHERNET
- For low, medium, and high forces
- For standard and high-precision applications
- 32-bit position resolution for short, medium, and long stroke ranges
- Point to point motions and travel along setpoint curves and motion profiles
- Integrated brake chopper for external brake resistor
- Output for controlling a mechanical brake
- Inputs for external end position and reference switches

- Fast trigger inputs
- Event Capture Input
- Safe pulse inhibitor
- Integrated sequence controller
- Position Indexing
- Position Streaming
- Synchronization to feeds and conveyor belts
- Electronic cam disc / Master Encoder
- Master-slave synchronization for gantry applications
- Technology blocks for standard applications
- Configurable via ETHERNET or fieldbus interfaces
- Control of linear and rotary motor

Servo Drive Series B1100

Single-axis drive for simplest and standard positioning tasks.

- Analog, digital, and CAN/RS232/485 interfaces, encoder simulation
- For low, medium, and high forces
- For standard and high-precision applications
- 32bit position resolution for short, medium, and long stroke ranges
- Position Indexing
- Position Streaming
- Control of linear and rotary motors
- Output for controlling a mechanical brake
- End position and reference switches

Servo Drive	Series E100	Series E1001	Series E1400	Series E1200
Controllable Actuators				
Linear Motors Series P01	★	★	-	★
Linear Motors Series P10	-	-	★	-
Linear Motors Generic (3rd Part)	-	-	★	★
DC Motors	-	-	★	★
EC Motors (Brushless DC Motors)	-	-	★	★
Torque Motors	-	-	★	★
Electric Properties				
Motor Supply Voltage DC	24...48VDC	24...72VDC	200...750VDC	24...85VDC
Motor Supply Voltage AC	-	-	3x200...480VAC	-
Max. Phase Current	3A _{pk}	8A _{pk}	40A _{pk}	32A _{pk}
Internal Chopper	No	Yes	Yes	Yes
Interfaces				
Analog Force/Torque	-	-	★	★
Analog Velocity	-	-	★	★
Analog Position	★	★	★	★
Step/Direction	★	★	★	★
RS232	★	★	★	★
RS485	★	★	★	★
CANopen	★	★	★	★
DeviceNet	★	★	-	-
Profibus DP	★	★	★	★
ETHERCAT	-	-	★	★
PROFINET	-	-	★	★
ETHERNET IP	-	-	★	★
SERCOS III	-	-	★	★
POWERLINK	-	-	★	★
Configuration Interfaces				
RS232 - Single Axes	★	★	★	★
CAN - Multi Axes	★	★	-	-
Ethernet - Multi Axes	-	-	★	★
Ethernet - Remote Maintenance	-	-	★	★
Motion Commands				
Position Streaming P, PV, PVT	-	-	★	★
Interpolated Moves VA-limited	★	★	★	★
Interpolated Moves Bestehorn	-	-	★	★
Curves Time Based	★	★	★	★
Curves Master Encoder	★	★	★	★
Belt Synchronization	-	-	★	★
Command Table	★	★	★	★
Winding Application	★	★	★	★
Closed Loop Force Control	-	-	★	★
Customer Specific Functionalities	★	★	★	★
Position Feedback				
LinMot Encoder	★	★	Motor Link C	Motor Link P
SinCos (1Vpp)	-	-	★	★
Incremental Encoder A,B,Z (RS422)	★	★	★	★
Incremental Encoder A,B,Z (RS422) with U,V,W	-	-	-	★
Incremental Encoder A,B,Z (RS422) with U,V,W (RS422)	-	-	★	★
Absolute Encoder SSI	-	-	★	★
Absolute Encoder Analog	-	-	★	★
Encoder Emulation Output A,B,Z (RS2422)	-	-	★	★
Synchronisation				
Master Encoder Input A,B,Z (RS422)	★	★	★	★
Master Encoder Output A,B,Z (RS422)	★	★	★	★
Digital & Analoge Interfaces				
Digital Inputs 24VDC	8	8	1	1
Digital IO 24VDC	0	0	8	8
Digital Outputs 24VDC	4	4	0	0
Analog Inputs 0...10VDC	4 (10 Bit)	4 (10 Bit)	1 (12 Bit)	1 (12 Bit)
Analog Inputs -10...+10VDC	-	-	1 (12 Bit)	1 (12 Bit)
Brake Output	-	-	24V/1A	24V/1A
Safety Functions				
Seperate Power Supply Input	★	★	★	★
Safety Voltage Enable SVE	-	-	-	★
Safety Relais	-	-	x (-1S)	-
STO - Safe Torque Off	-	-	x (-1S)	-
Resoluition & Timings				
Position Drive Resolution	16 Bit	16 Bit	32 Bit	32 Bit
Position Drive Update Rate	-	-	8kHz	10kHz
I/O Update Rate	1.6ms	1.6ms	4kHz	5kHz
I/O Update Rate Trigger and Capture Input	1.25kHz	1.25kHz	8kHz	10kHz
Current Drive Frequency	2.5kHz	2.5kHz	16kHz	20kHz
PWM Frequency	-	-	8kHz	20kHz
Approvals				
CE	CE	CE	CE	CE
UL	-	-	UL pending	UL pending

Servo Drive	Series C1200	Series E1100	Series B1100
Controllable Actuators			
Linear Motors Series P01	★	★	★
Linear Motors Series P10	-	-	-
Linear Motors Generic (3rd Part)	★	★	★
DC Motors	★	★	★
EC Motors (Brushless DC Motors)	★	★	★
Torque Motors	★	★	★
Electronic Properties			
Motor Supply Voltage DC	24...85VDC	24...85VDC	24...85VDC
Motor Supply Voltage AC	-	-	-
Max. Phase Current	25A _{pk}	8 / 15 / 25A _{pk}	8 / 15 / 25A _{pk}
Internal Chopper	No	Yes	No
Interfaces			
Analog Force/Torque	★	★	★
Analog Velocity	★	★	★
Analog Position	★	★	★
Step/Direction	★	★	★
RS232	★	★	★
RS485	★	★	★
CANopen	★	★	★
DeviceNet	-	★	★
Profibus DP	★	★	-
ETHERCAT	★	-	B1150
PROFINET	★	-	B1150
ETHERNET IP	★	-	B1150
SERCOS III	★	-	B1150
POWERLINK	★	-	B1150
Configuration Interfaces			
RS232 - Single Axes	★	★	★
CAN - Multi Axes	-	★	★
Ethernet - Multi Axes	-	-	-
Ethernet - Remote Maintenance	-	-	-
Motion Commands			
Position Streaming P, PV, PVT	★	★	★
Interpolated Moves VA-limited	★	★	★
Interpolated Moves Bestehorn	★	★	★
Curves Time Based	★	★	★
Curves Master Encoder	-	★	-
Belt Synchronization	-	★	-
Command Table	★	★	★
Winding Application	★	★	★
Closed Loop Force Control	★	★	★
Customer Specific Funtionalities	★	★	★
Position Feedback			
LinMot Encoder	Motor Link P	Motor Link P	Motor Link P
SinCos (1Vpp)	★	★	-
Incremental Encoder A,B,Z (RS422)	★	★	★
Incremental Encoder A,B,Z (RS422) with U,V,W	★	★	★
Incremental Encoder A,B,Z (RS422) with U,V,W (RS422)	★	★	★
Absolute Encoder SSI	★	-	-
Absolute Encoder Analog	★	★	★
Encoder Emulation Output A,B,Z (RS2422)	-	-	★
Synchronisation			
Master Encoder Input A,B,Z (RS422)	-	★	-
Master Encoder Output A,B,Z (RS422)	-	★	-
Digital & Analoge Interfaces			
Digital Inputs 24VDC	4	0 / 16 (GP)	6
Digital IO 24VDC	0	9	0
Digital Outputs 24VDC	5	0 / 8 (GP)	6
Analog Inputs 0...10VDC	-	1 (10 Bit)	1 (10Bit)
Analog Inputs -10...+10VDC	-	0	1 (10Bit)
Brake Output	24V/0.5A	24V/1A	24V/0.5A
Safety Functions			
Seperate Power Supply Input	★	★	★
Safety Voltage Enable SVE	-	★(RS, CO, DN,DP)	-
Safety Relais	★(-1S)	-	-
STO - Safe Torque Off	★(-1S)	-	-
Resolutuion & Timings			
Position Drive Resolution	32 Bit	32 Bit	32 Bit
Position Drive Update Rate	10kHz	3kHz	5kHz
I/O Update Rate	5kHz	1.5kHz	2.5kHz
I/O Update Rate Trigger and Capture Input	10kHz	3kHz	5kHz
Current Drive Frequency	20kHz	6kHz	10kHz
PWM Frequency	20kHz	20kHz	20kHz
Approvals			
CE	CE	CE	CE
UL	UL pending	UL	-

Servo Drive E100/E1001

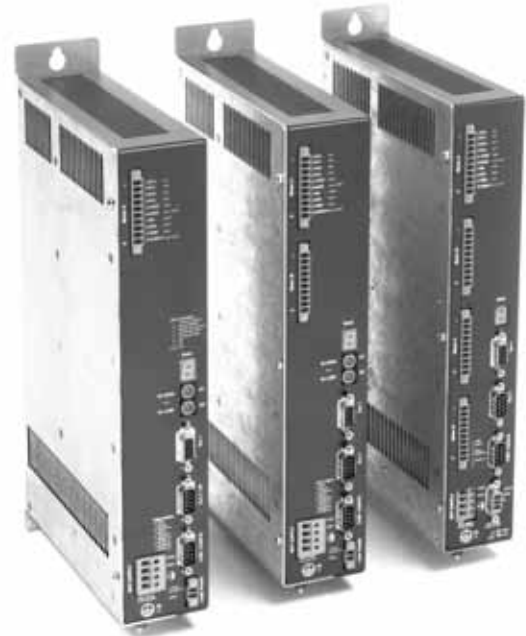

Series E100/E1001-AT/MT

330

Series E100/E1001-CO/DN

332

Series E130/E1031-DP

334

Servo Drive Series E100/E1001

The Series E100 Servo Drive and powerful Series E1001 are compact, one, two or four-axis position drives with 16-bit position resolution and integrated power elements.

The drives are suitable for simple and standard positioning tasks in the low to medium force range.

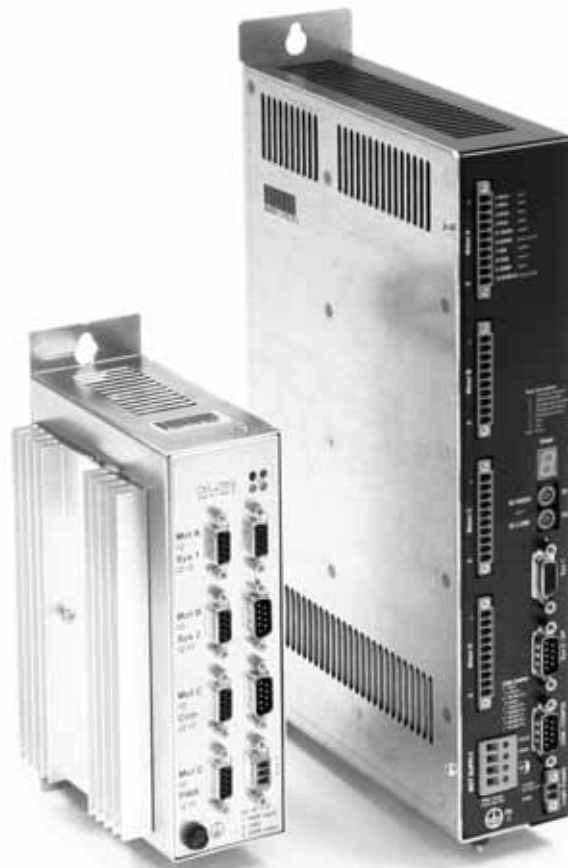

Motor Interfaces

Series E100 and E1001 Servo Drives allow control of up to four linear motors by one drive.

The linear motors themselves are operated without any complicated peripherals, such as end position monitors or reference switches.

The individual linear motors are either completely independently controlled, or they are synchronized with each other in special applications, in master booster or master gantry mode.

Connection to Machine Drive

The E100 and E1001 series Servo Drives can be controlled through the following interfaces:

- Digital inputs and outputs
- Analog Inputs
- RS232 Serial Interface
- RS485 Serial Interface
- CANopen
- DeviceNet
- Profibus DP

Process Interfaces

As a fast process interface for direct reading of sensor signals, one combined analog/digital input per drive is available as an analog position target or a trigger input.

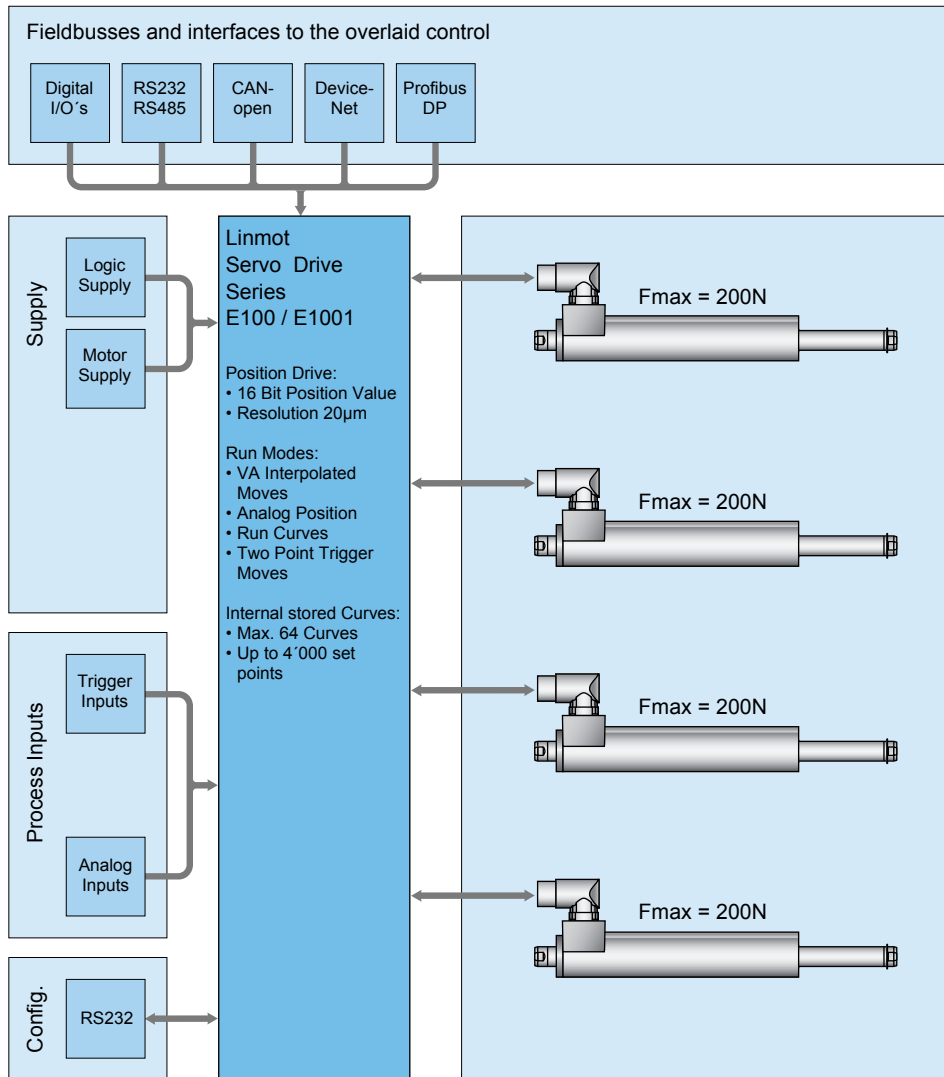

System Integration

Series E100/E1001 drives are suitable for controlling linear motors that are operated without optional peripherals such as reference and end stop switches, external high-precision position sensors, or a holding brake.

Connection to the overlaid control is done via analog and digital signals, a serial connection, or fieldbuses.

The compact size is a great advantage of the Series E100/E1001 Servo Drives, primarily for compound and multi-axis applications, with regard to installation space and effort.

Logic and Power Supply

The Servo Drives have two separate power supplies for the logic and power elements.

In an E-stop and safe stop of the drive, only the power element supply is cut off from the drive. The logic supply and the drive continue to run.

This has the advantage that the drive and linear motor do not need to be reinitialized when the machine is restarted, since all process data, including the current position of the linear motor, are still up to date.

Servo Drive E400 in use

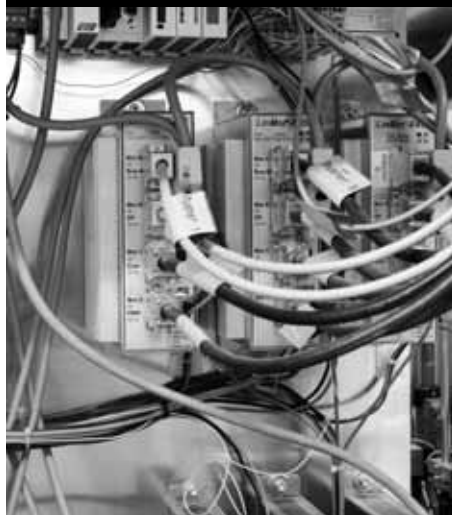

Configuration

Parameterization and configuration of the Servo Drive is done via the RS232 interface on the front side.

The menu-drive Windows interface LinMot Talk is used for configuration, with which up to four Axis can be configured simultaneously on one drive. LinMot Talk provides extensive debugging tools, such as an oscilloscope and an error inspector, for simple and rapid start-up of the Axis.

Absolute & Relative Positioning Commands

Stroke [mm]

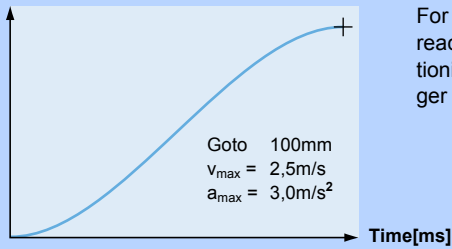

For direct position targets, using absolute or relative positioning, the desired position is reached according to acceleration and velocity-limited motion profiles (VA interpolator). Positioning commands can be invoked via the serial interface, fieldbuses, ETHERNET, or the trigger input.

Stroke range:	±630mm
Position Resolution:	20µm (16 Bit)
Velocity Resolution:	1.0µm/s (16 Bit)
Acceleration:	10.0µm/s ² (16 Bit)

Travel Along Time Curves

Stroke [mm]

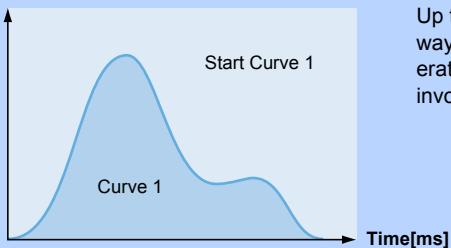

Up to 99 different time curves can be stored Series E1100 drives, with up to 16,000 individual waypoints. The motor can thus travel along time curves of any complexity, such as those generated by CAD programs and stored in the drive (Excel CSV format). The time curves can be invoked via the serial interface, fieldbuses, ETHERNET, or the trigger input.

Stroke range:	±630mm
Position Resolution:	20µm (16 Bit)
Motion profiles:	max. 64 curve profiles
Curve points:	max. 4'000points

Analog Position Target

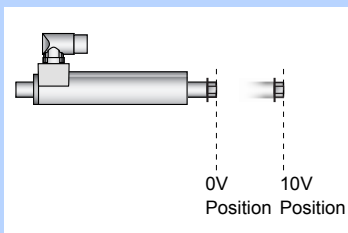

For an analog position target, the linear motor travels to a position proportional to the input voltage. The position is continuously read. In order to prevent uncontrolled jumps in position, the motor travels to the positions with a programmable maximum acceleration and velocity (VA interpolator).

Inputs:	1 analog input per motor
Voltage range:	0-10VDC
Resolution:	10 Bit
Scanning rate:	800µsec

Trigger 2 Point

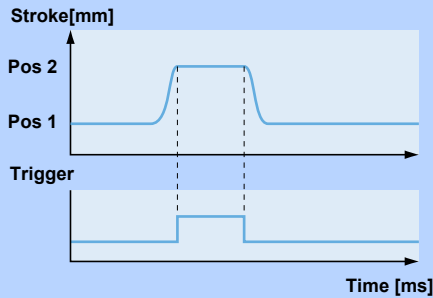

In the two-point trigger operating mode, two freely adjustable positions are controlled by the overarching drive, using a trigger signal.

One target value for the high level, and one for the low level of the digital input signal are stored in the drive electronics. If the signal at the drive electronics input changes, then the associated position is moved to at the programmed acceleration and speed.

Stroke range:	±630mm
Position Resolution:	20µm (16 Bit)
Velocity Resolution:	1.0µm/s (16 Bit)
Acceleration:	10.0µm/s ² (16 Bit)

Master Slave Synchronization

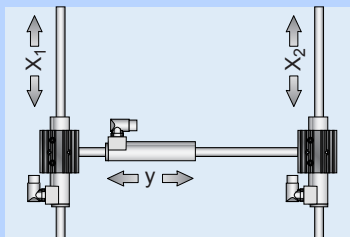

Using master-slave synchronization, two linear motors can be synchronized via a serial communications connection between two drives, so that the overlaid drive can control them as a single axis.

Master Gantry Synchronization

Master gantry synchronization is used for portal designs with two parallel Axis at different locations.

Master Booster Synchronization

Master booster synchronization is used to double the force when two motors are mechanically rigidly connected to each other.

Internal Command Table

Multi Trigger

Command 1	Pos 125mm
Command 2	Pos 250mm
Command 3	Curve 1
Command 4	Pos -30mm
Command 5	Pos +12,5mm
...	
...	
Command 64	Pos -12,5mm

With the Multi-Trigger-Table, up to 64 positions or independent travel commands can be stored on the drive and addressed directly or indirectly via 4 digital inputs.

Digital inputs:	Max. 4
Interface:	Sys2
Scanning rate:	800µsec

LinMot Talk

LinMot Talk configuration software is a Windows-based interface that supports the user during start-up and configuration of the LinMot Series E100 and E1001 Servo Drives. The software has a powerful, modular, graphical interface that covers all the tasks surrounding the LinMot Servo Drive. Great emphasis was placed on a high level of user-friendliness during development.

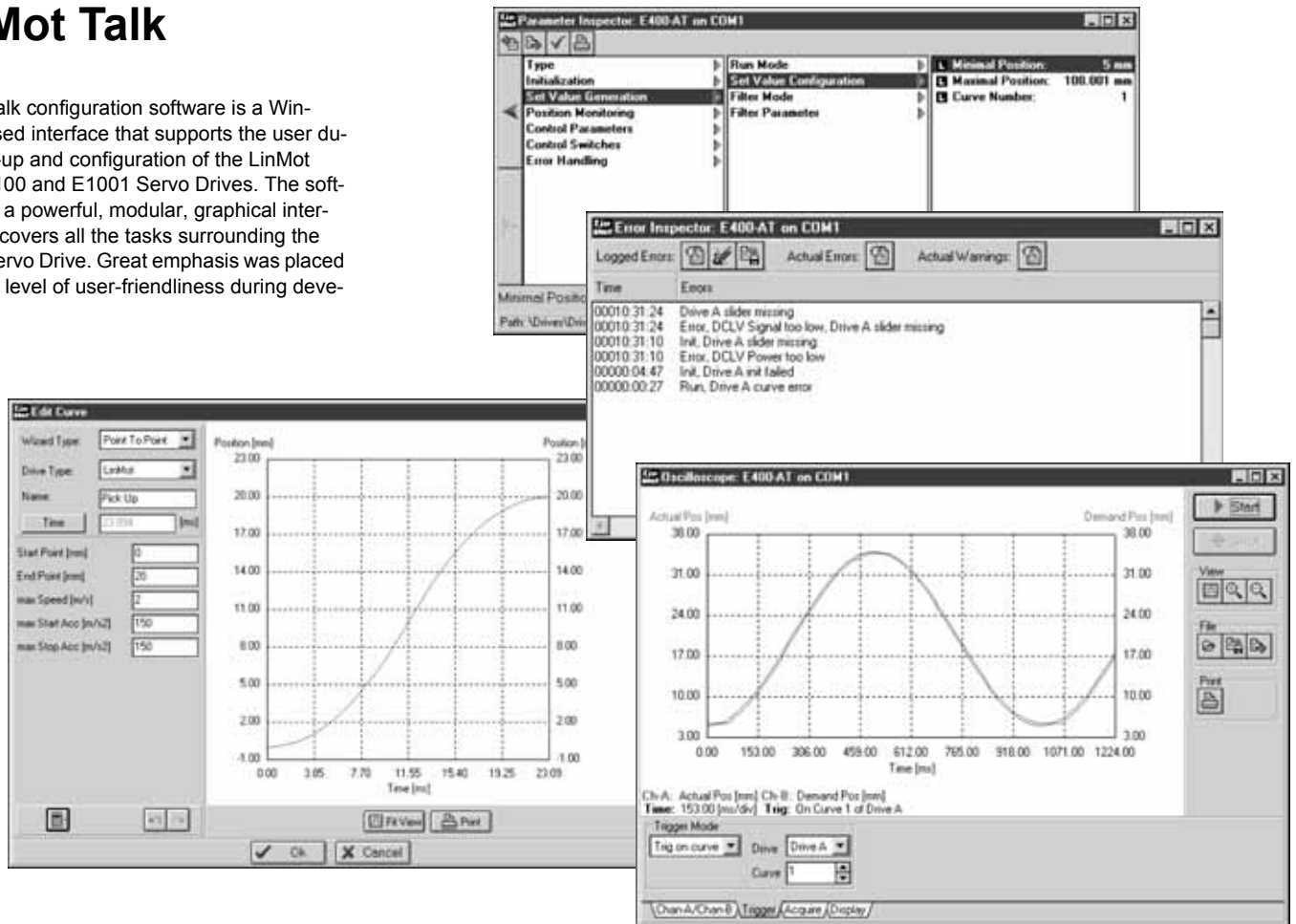

Start-up and Analysis Tools

Using the LinMot Talk PC interface, LinMot Servo Drives are configured. Additionally, the drives can be monitored during operation with the machine running, and the current motion sequences, as well as earlier warnings and error messages, can be analyzed in detail (monitoring).

Simple Installation

For start-up and monitoring, the Servo Drive is connected to a PC via the RS232 interface on the front, using a 9-pole D-sub connector (1:1 Connection). Up to four Axis on one drive can be configured and monitored at the same time using LinMot Talk.

Integrated Documentation

After installation of LinMot Talk on the PC is complete, all manuals and installation instructions are available via the Windows Start Menu. The user thus always has the current documentation available to him.

Parameterization

Using the "Parameter Inspector," the drives are parameterized in a simple manner. The user has a wide range of adjustments available for operating modes, error management, warning messages, and regulating parameters. Entire parameter sets can be stored, loaded, and printed out.

The "Curve Editor" allows creation of travel curves. In addition, existing curves can be loaded, stored, edited, combined, and printed out. Further, complex motion sequences can be generated as desired in MS Excel, and loaded into the drive.

The integrated oscilloscope helps the user during start-up and optimization of the

Optimization

drive system. Internal variables, such as the target and actual position, can be shown in real time on the screen, and then printed out. The displayed data can be stored in CSV format for further processing in MS Excel, or stored for documentation purposes.

Monitoring

Using the "Error Inspector," the user can read out stored errors, as well as the currently active warnings and error messages in the LinMot Servo Drive. The last 10 error messages are stored in non-volatile memory on the Servo Drive, together with the operating hours counter.

Further, the states of the inputs and outputs can be viewed in the "Error Inspector." This allows rapid and uncomplicated checking of signals from and to the overlaid control.

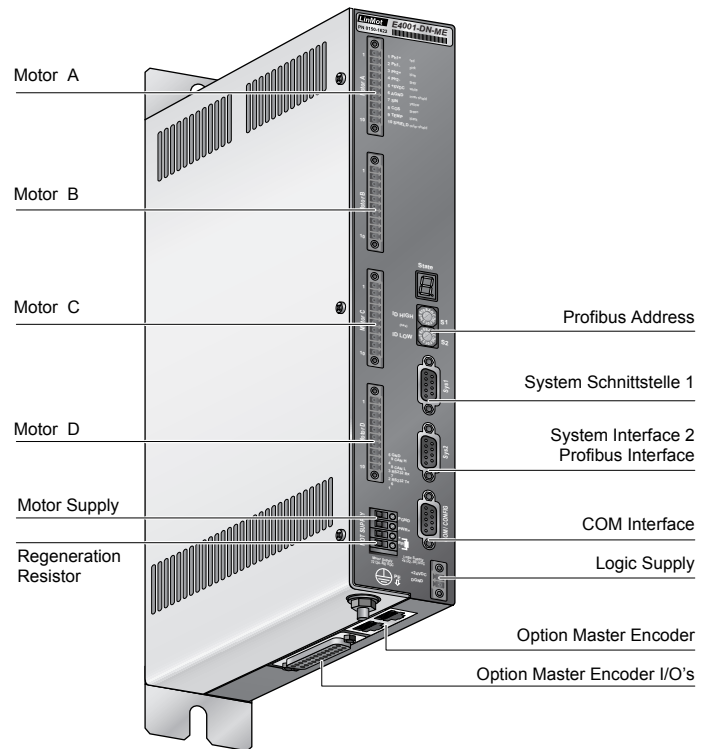
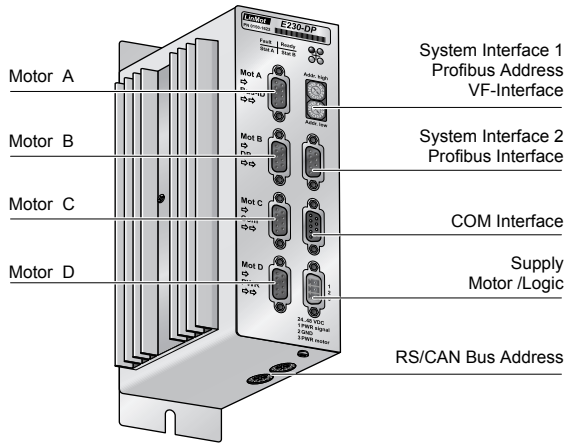

	E100-AT	E1001-AT	E100-MT	E1001-MT	E100-CO	E1001-CO	E100-DN	E1001-DN	E130-DP	E1031-DP
Interface										
System Interface 1	•	•	•	•	•	•	•	•		
System Interface 2	•	•	•	•	•	•	•	•		
Profibus Address		•		•		•		•	•	•
Profibus Interface									•	•
COM Interface	•	•	•	•	•	•	•	•	•	•
Supply Motor		•		•		•		•		•
Supply Logic		•		•		•		•		•
Supply Logic/Motor	•		•		•		•		•	
Regeneration Resistor		•		•		•		•		•
Bus Address RS/CAN	•	•	•	•	•	•	•	•		
Motor Connector DSUB-9	•		•		•		•		•	
Motor Connector MC01-P		•		•		•		•		•

E100-AT	E100-MT
E200-AT	E200-MT
E400-AT	E400-MT
E1001-AT	E1001-MT
E2001-AT	E2001-MT
E4001-AT	E4001-MT

- ✓ Absolute & Relative Positioning Commands
- ✓ Travel Along Time Curves
- ✓ Trigger Mode: Two Point
- ✓ Trigger Mode: Curves
- ✓ Internal Multi Trigger Table (MT)
- ✓ Analog Position Target
- ✓ Master-Slave Synchronization
- ✓ Option: Customer-Specific Functions (MT)

E100, E200, E400-AT/MT

Mot A
Motor A

Mot B
Motor B

Mot C
Motor C

Mot D
Motor D

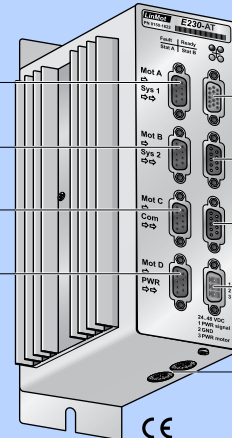

Sys 1
System Interface 1

Sys 2
System Interface 2

Com
COM Interface

PWR
Motor/Logic Supply

RS/CAN Bus Address

E1001, E2001, E4001-AT/MT

Mot A
Motor A

Mot B
Motor B

Mot C
Motor C

Mot D
Motor D

PWR Motor
Motor Power Supply
Regeneration Resistor

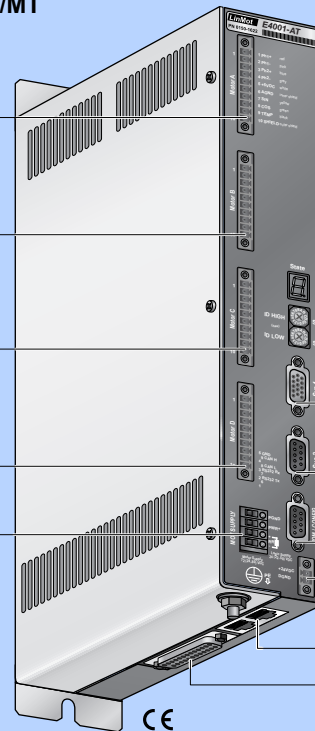

Sys 1
System Interface 1

Sys 2
System Interface 2

Com
COM Interface

PWR Logic
Logic Supply

Option Master Encoder

Option Master Encoder I/O's

Analog Trigger Drive AT

The target position is provided by the overlaid control (PLC, industrial PC) as analog position signals, digital trigger signals, or directly via a serial interface.

End positions stored in the AT Servo Drive, or stored travel profiles, can be invoked using simple digital trigger signals.

The target position is provided as a voltage at the analog input of the Servo Drive. The position range associated with the voltage range at the analog input can be freely configured by the user.

Multi Trigger Drive MT

Multi trigger Servo Drives allow direct programming of complex motion sequences, with up to 64 commands. The Servo Drive is actuated by the overlaid control via digital signals.

The commands for the individual Axis are stored in the state table in the Servo Drive. The individual states in the table are controlled by the overlaid control via digital signal addressing. As soon as a state is invoked by the overlaid control, the Axis carry out their defined motion or defined command.

Serial Interface RS232/RS485

Series E100/E1001E1001-AT and -MT Servo Drives offer an ASCII protocol for serial communication over RS232 / RS484 with the overlaid control system.

The E100/E1001 drives have two independent serial interfaces for RS232 and RS485. If the Servo Drive communicates with the RS485 interface with the overlaid control, the RS232 interface may be used the same time for configuration and debugging with configuration software LinMot Talk.

Adjustable Baud rates: 9.6-115.2kBaund

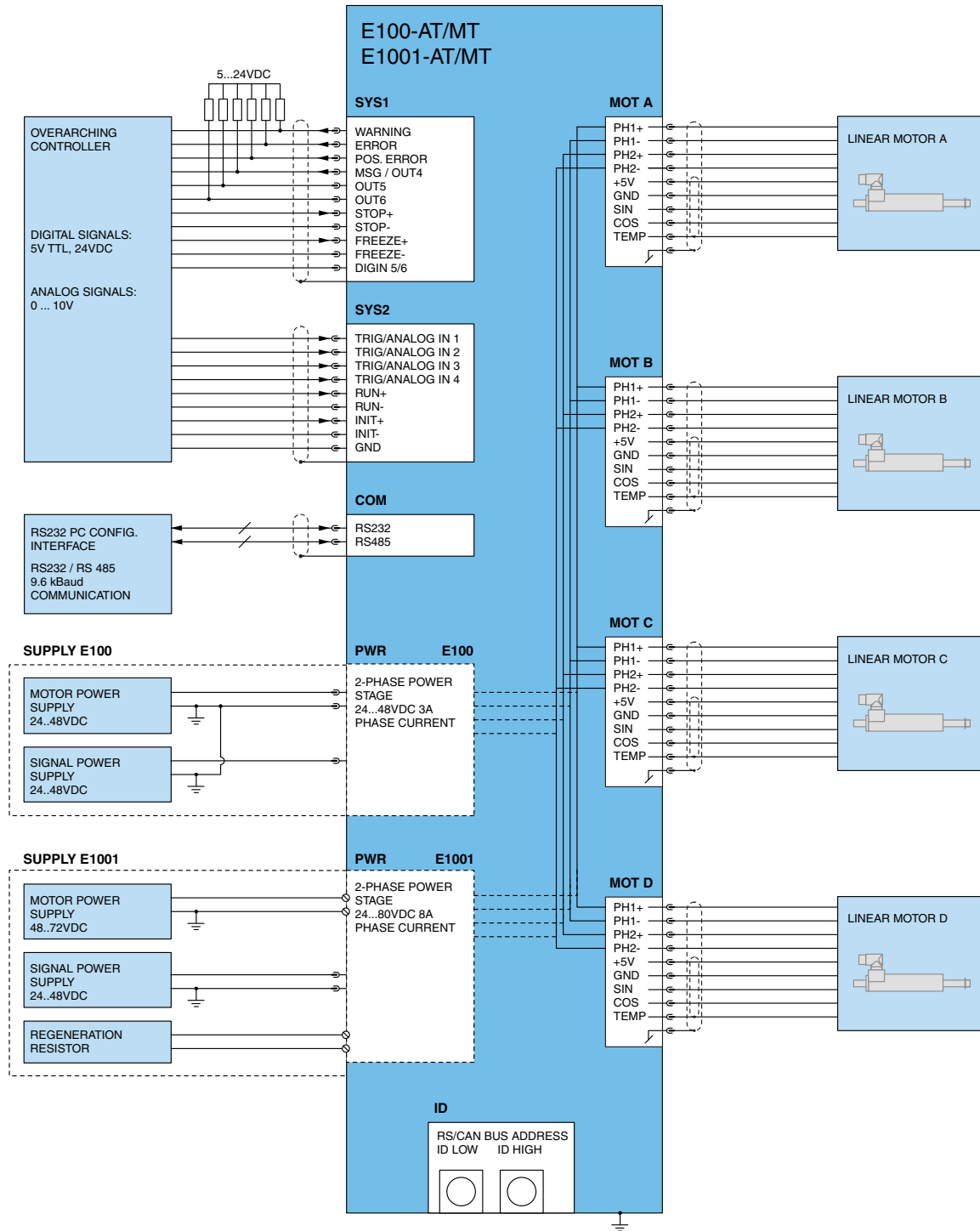

Item	Description	Part Number
E100-AT	AnalogTrigger Drive 1 Axis (48V/3A)	0150-1601
E200-AT	AnalogTrigger Drive 2 Axis (48V/3A)	0150-1602
E400-AT	AnalogTrigger Drive 4 Axis (48V/3A)	0150-1604
E1001-AT	AnalogTrigger Drive 1 Axis (72V/8A)	0150-2300
E2001-AT	AnalogTrigger Drive 2 Axis (72V/8A)	0150-2301
E4001-AT	AnalogTrigger Drive 4 Axis (72V/8A)	0150-2303
E100-MT	Multi Trigger Drive 1 Axis (48V/3A)	0150-1611
E200-MT	Multi Trigger Drive 2 Axis (48V/3A)	0150-1612
E400-MT	Multi Trigger Drive 4 Axis (48V/3A)	0150-1614
E1001-MT	Multi Trigger Drive 1 Axis (72V/8A)	0150-2304
E2001-MT	Multi Trigger Drive 2 Axis (72V/8A)	0150-2305
E4001-MT	Multi Trigger Drive 4 Axis (72V/8A)	0150-2307

E100-CO	E100-DN
E200-CO	E200-DN
E400-CO	E400-DN
E1001-CO	E1001-DN
E2001-CO	E2001-DN
E4001-CO	E4001-DN

- ✓ Absolute & Relative Positioning Commands
- ✓ Travel Along Time Curves
- ✓ Trigger Mode: Two Point
- ✓ Trigger Mode: Curves
- ✗ Internal Command Table
- ✓ Analog Position Target
- ✓ Master-Slave Synchronization
- ✓ Option: Customer-Specific Functions

E100, E200, E400-CO/DN

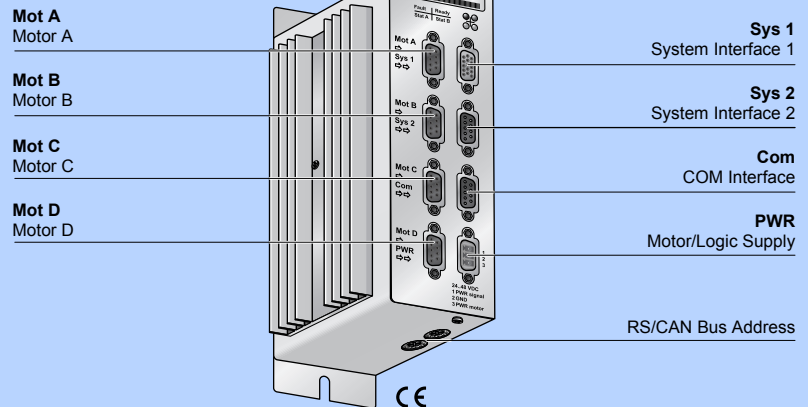

E1001, E2001, E4001-CO/DN

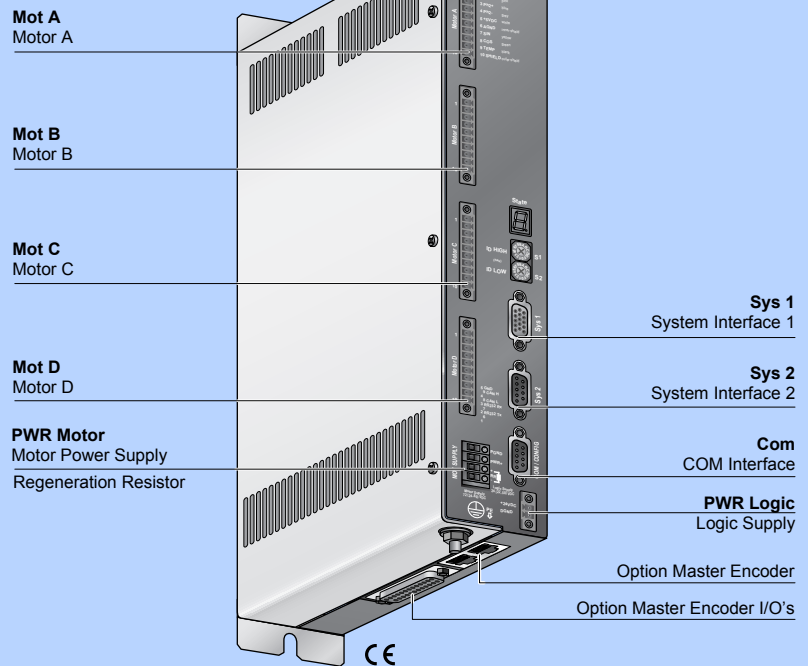

CANopen

LinMot CO drives, with integrated CANopen interface, support the CiA DS301 communication profile.

The following CANopen resources are available on the CO drives: 1-5 T_PDO, 1-5 R_PDO 1 T_SDO, 1 R_SDO

The following protocols are supported by the CO drives:

- Node Guarding
- PDO acyclic with inhibit time
- SDO Upload and Download
- NMT (Start, Stop, Enter PreOp, Reset Node, Reset Communication)
- Boot-Up Message

DeviceNet

Series DN drives feature an integrated DeviceNet interface. With the DeviceNet interface, even complicated motion sequences can be realized with the highest possible flexibility.

The drive can be actuated and monitored via the DeviceNet connection. The following expanded fieldbus functions are available:

- Direct target position
- Invoke motion profiles
- Read and write access to parameters
- Monitoring internal parameters
- Diagnosis

"Explicit Messaging" The DeviceNet Servo Drives support one "Explicit Messaging" connection per master.

"Polled IO"

The master initiates data interchange with a "Polled IO" command.

"Change of State IO"

With this connection, the data is transferred only if the states or values have changed.

"Cyclic IO"

With the "Cyclic IO" connection, the data is transferred strictly cyclically.

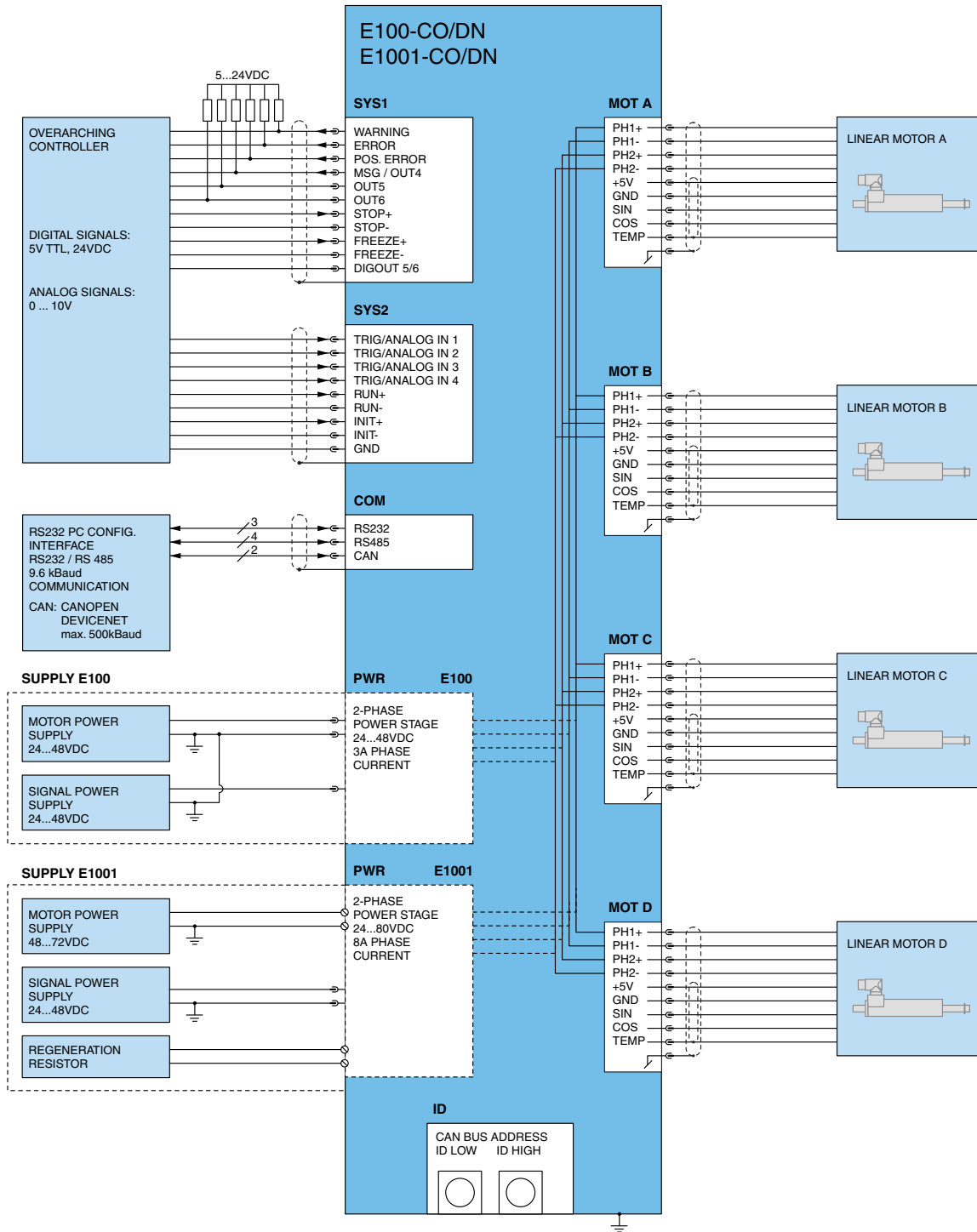

Item	Description	Part Number
E100-CO	CanOpen Drive 1 Axis (48V/3A)	0150-1669
E200-CO	CanOpen Drive 2 Axis (48V/3A)	0150-1670
E400-CO	CanOpen Drive 4 Axis (48V/3A)	0150-1672
E1001-CO	CanOpen Drive 1 Axis (72V/8A)	0150-2308
E2001-CO	CanOpen Drive 2 Axis (72V/8A)	0150-2309
E4001-CO	CanOpen Drive 4 Axis (72V/8A)	0150-2311
E100-DN	DeviceNet Drive 1 Axis (48V/3A)	0150-1641
E200-DN	DeviceNet Drive 2 Axis (48V/3A)	0150-1642
E400-DN	DeviceNet Drive 4 Axis (48V/3A)	0150-1644
E1001-DN	DeviceNet Drive 1 Axis (72V/8A)	0150-2312
E2001-DN	DeviceNet Drive 2 Axis (72V/8A)	0150-2313
E4001-DN	DeviceNet Drive 4 Axis (72V/8A)	0150-2315

E130-DP
E230-DP
E430-DP
E1031-DP
E2031-DP
E4031-DP

- ✓ Absolute & Relative Positioning Commands
- ✓ Travel Along Time Curves
- ✗ Trigger Mode: Two Point
- ✗ Trigger Mode: Curves
- ✗ Internal Command Table
- ✗ Analog Position Target
- ✓ Master-Slave Synchronization
- ✓ Option: Customer-Specific Functions

E130, E230, E430-DP

Mot A
Motor A

Mot B
Motor B

Mot C
Motor C

Mot D
Motor D

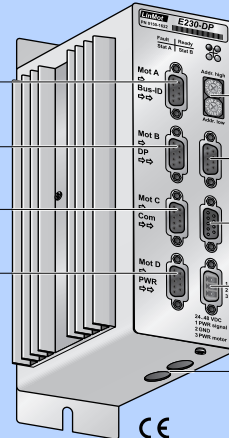

ID
Profibus Bus Address

DP
Profibus Interface

Com
COM Interface

PWR
Motor/Logic Supply

E1031, E2031, E4031-DP

Mot A
Motor A

Mot B
Motor B

Mot C
Motor C

Mot D
Motor D

PWR Motor
Motor Power Supply
Regeneration Resistor

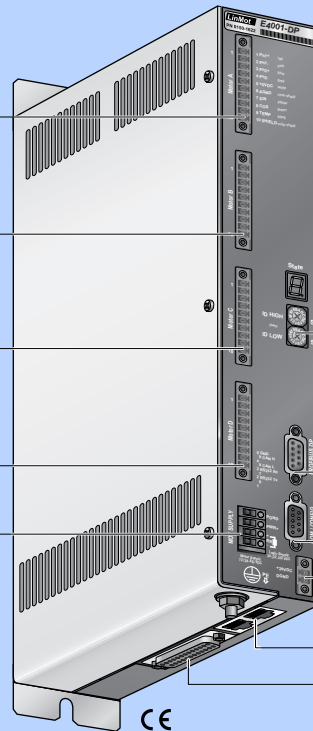

ID
Profibus Bus Address

DP
Profibus Interface

Com
COM Interface

PWR Logic
Logic Supply

Option Master Encoder

Option Master Encoder I/O's

Profibus DP

Series DP Servo Drives feature an integrated PROFIBUS DP interface. PROFIBUS-DP provides the user with a standardized fieldbus interface for rapid data interchange between the Servo Drive and the overlaid control.

With cyclical provision of target positions and other process data, the Profibus drives are the ideal solution for applications with motions and sequences that change frequently, such as are required, for example, in flexible machines and systems for rapid format changes.

The Profibus interface supports all Baud rates from 9.6 Kbits/s to 12 Mbit/s. The maximum net data quantity exchanged in cyclical data traffic is 64 bytes per cycle. The smallest achievable bus cycle time is 100 μ s. The structure and scope of cyclical data can be collected from any individual data modules into an overall data quantity when planning the system, whereby the data for the individually connected motors can be different.

A GSD device master file is provided for open planning in conformance with the standard.

The front-side 9-pin DSUB bus connector meets the PROFIBUS standard. It provides power for an external bus termination. A positive directional control signal is provided to control repeaters or optical fibers.

All signals on the PROFIBUS connector are galvanically separated.

The PROFIBUS-DP address is set by two hex code switches (ID1 and ID2). All addresses permitted by the standard are supported (0..125).

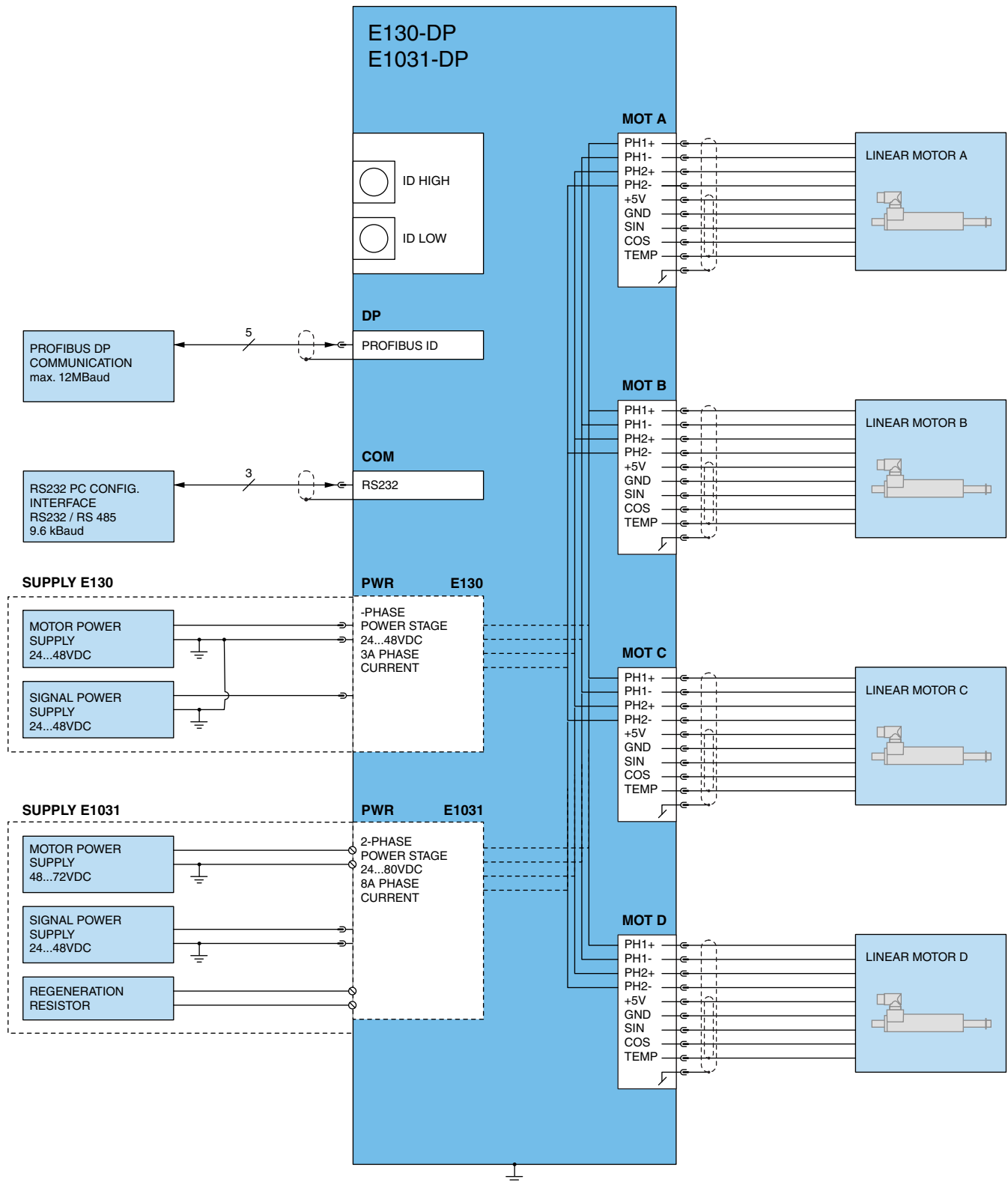

Item	Description	Part Number
E130-DP	Profibus DP Drive 1 Axis (48V/3A)	0150-1621
E230-DP	Profibus DP Drive 2 Axis (48V/3A)	0150-1622
E430-DP	Profibus DP Drive 4 Axis (48V/3A)	0150-1624
E1031-DP	Profibus DP Drive 1 Axis (72V/8A)	0150-2316
E2031-DP	Profibus DP Drive 2 Axis (72V/8A)	0150-2317
E4031-DP	Profibus DP Drive 4 Axis (72V/8A)	0150-2319

Break Out Module

The Break Out Module for the AT and MT Servo Drives leads all input and output signal from the SYS1 and SYS2 DSUB connectors to plug-type screw terminals.

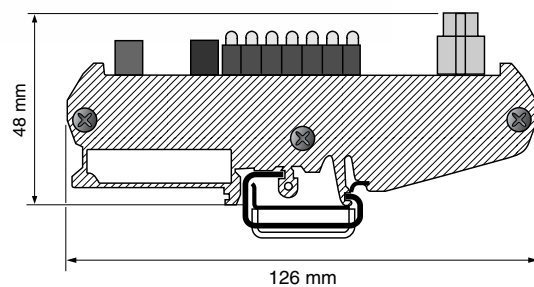

Break Out Module

The Break Out Module is available in two versions, with a digital or analog interface.

The Break Out Module is snapped onto the DIN rail directly in the electrical enclosure. Two tabs for screw mounting are also included.

Features:

- Plug-type screw terminals for all inputs and outputs
- Digital inputs, galvanically isolated, (24V/10mA)
- Digital outputs, galvanically isolated, (24V/0.5A)
- Relay output (48V/2A, max. 60W)
- LED status indicator for all inputs and outputs
- Analog input voltage -10...+10V for analog module.

Cable & Connector Set

The connection cable to the Servo Drive and the plug-type screw terminals are available as a set.

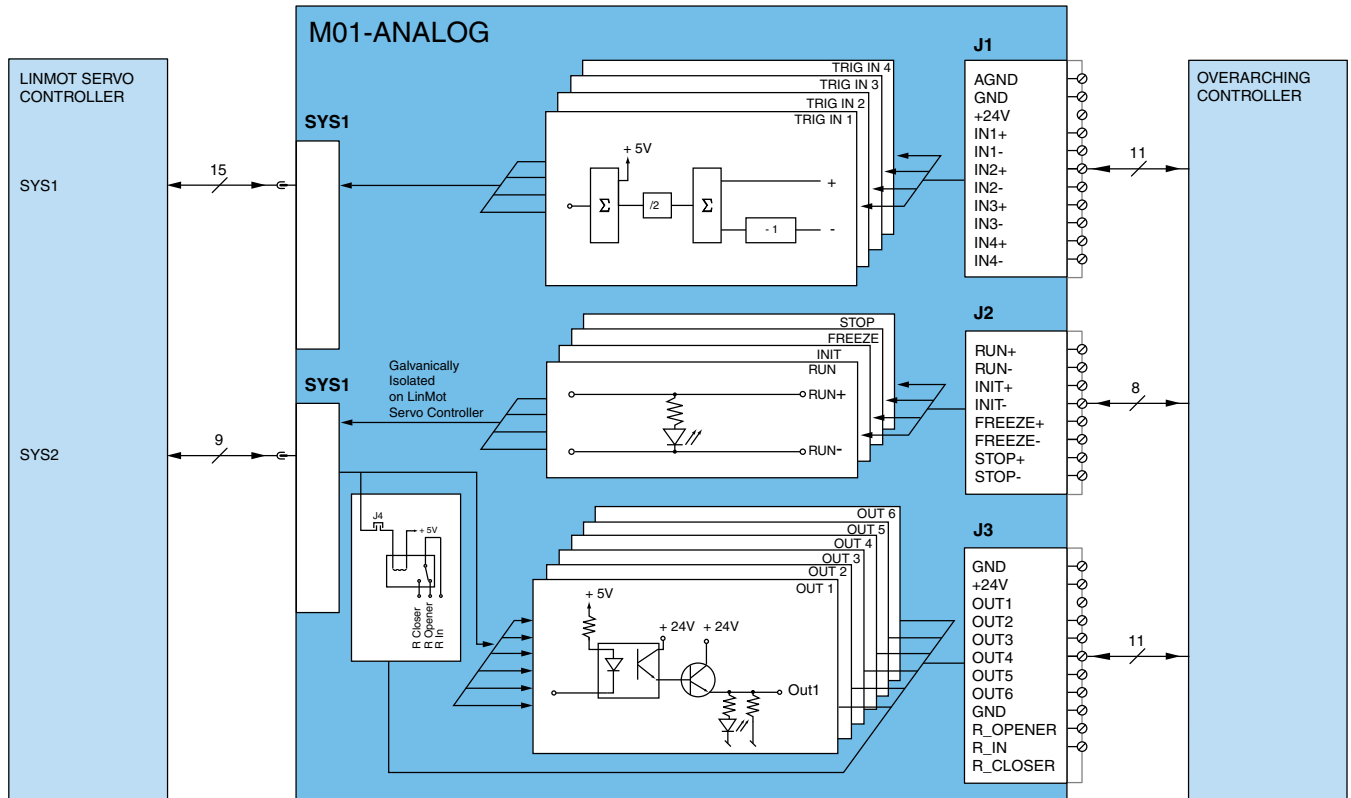
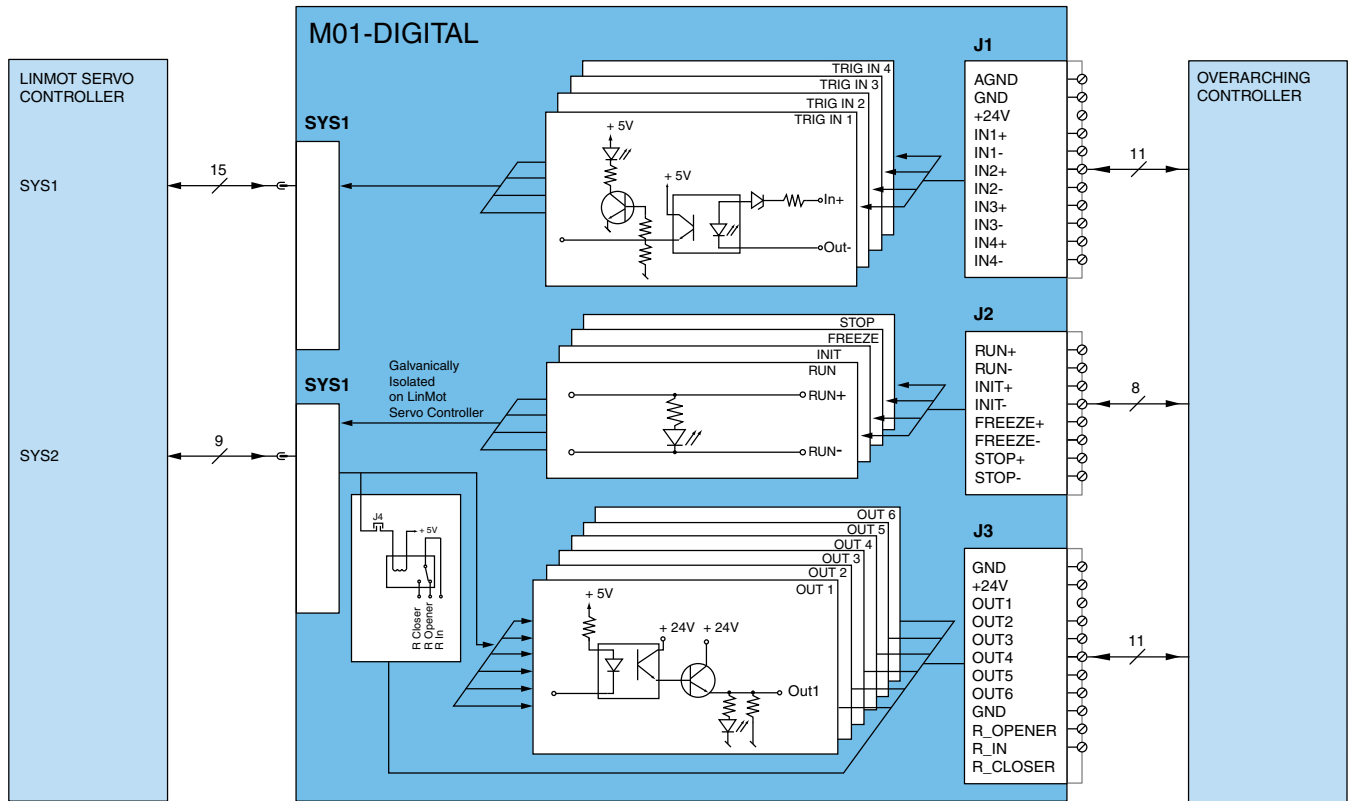

Item	Description	Part Number
M01-digital	Breakout Module digital	0150-1932
M01-analog	Breakout Module analog	0150-1933
M01-Connector	Cable and Connector set	0150-1934

E100

Supply Motor/Logic

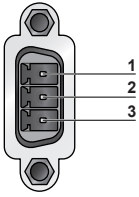

Power Connector
Logic/Motor
1.5 mm² (AWG16)

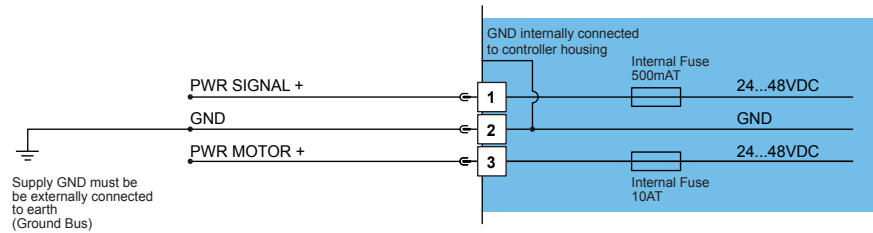

Supply

Supply Voltage Logic: 24...48VDC (absolute max. Rating 48VDC + 10%)
Supply Voltage Motor: 24...48VDC (absolute max. Rating 48VDC + 10%)

Motor Supply GND must be externally connected to earth



- By exceeding 52VDC supply voltage, the drive will go into error state.
- Power supply connectors must not be connected or disconnected while DC voltage is present.

E1001

Supply Motor/Logic

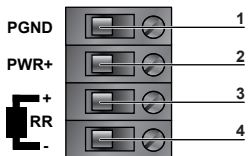

Screw Terminals
2.5 mm² (AWG14)

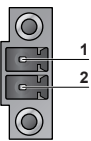

Phoenix MC1,5/2-STF-3.81
0.25-1.5mm² (AWG24-16)

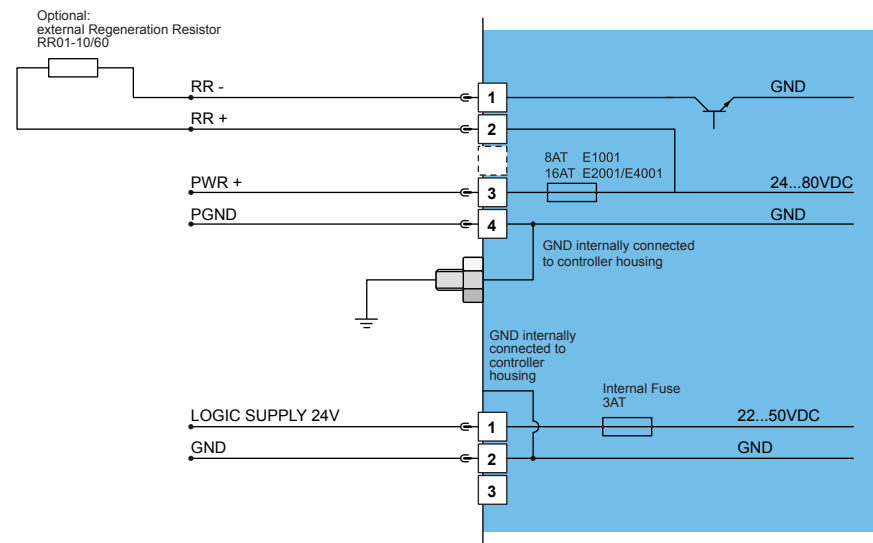

Supply:

Supply Voltage Logic: 24...80VDC (absolute max. Rating 92VDC)
Supply Voltage Motor: 48...72VDC (absolute max. Rating 72VDC + 5%)

Motor and Logic Supply GND must be externally connected to earth



- By exceeding 92VDC motor supply voltage, the drive will go into error state.
- By exceeding 52VDC logic supply voltage, the drive will go into error state.
- Power supply connectors must not be connected or disconnected while DC voltage is present.
- It is recommended that the motor and the logic be supplied and controlled separately.

Mot A (B, C, D) Motor connector E100

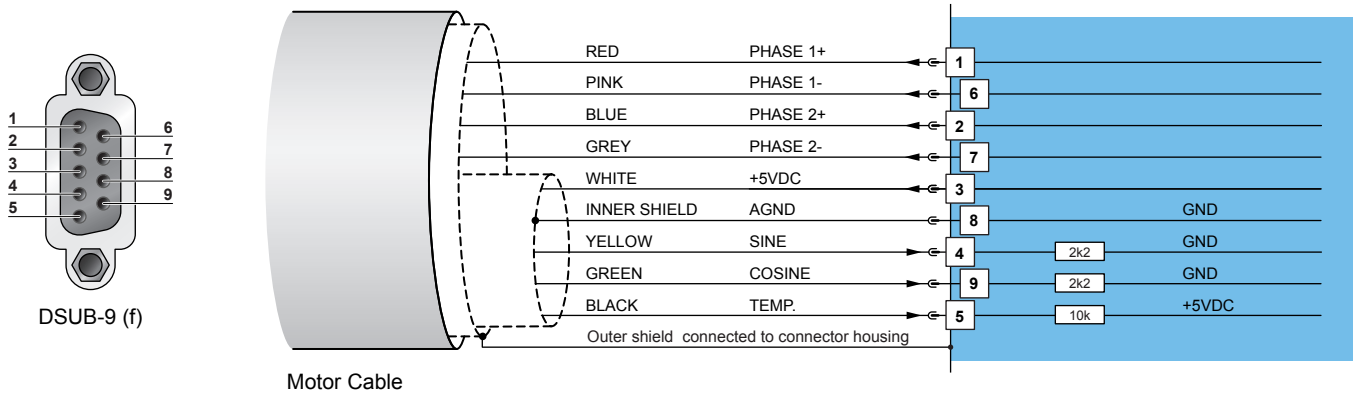

Mot A (B, C, D) Motor connector E1001

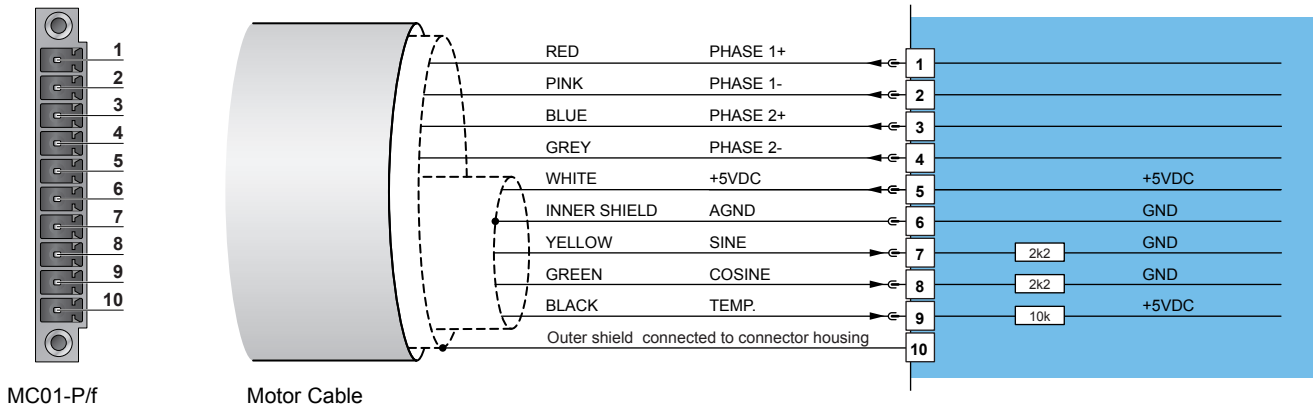

Motor Cable

- Use only special double-shielded Linear Motor Cable (see motor accessories).
- LinMot offers a wide range of preassembled motor cable in standard and custom length (tested 1.5kV):
 - Standard Cable K05-...
 - High-Flex Cable KS05-...
 - Robot-Cable KR05-...
- Do NOT connect AGND (Pin 6) to ground or earth!
- Inner shield (AGND) and outer shield (earth) must be isolated to each other.
- Use +5V (Pin 3) and AGND (Pin 6) only for motor internal Hall Sensor supply (max. 100mA).



- Wrong Motor wiring may damage Linear Motors and/or Servo Drive.
If you are assembling motor cables by your own, double check motor wiring carefully before power up.
- Do not connect or disconnect the motors from drives with voltage present.
Wait to connect or disconnect motors until all LinMot drive LED's have turned off.

SYS1

System interface 1

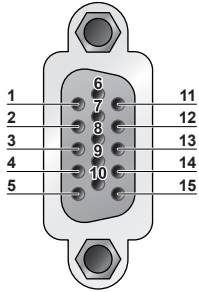

DSUB-15 (f)

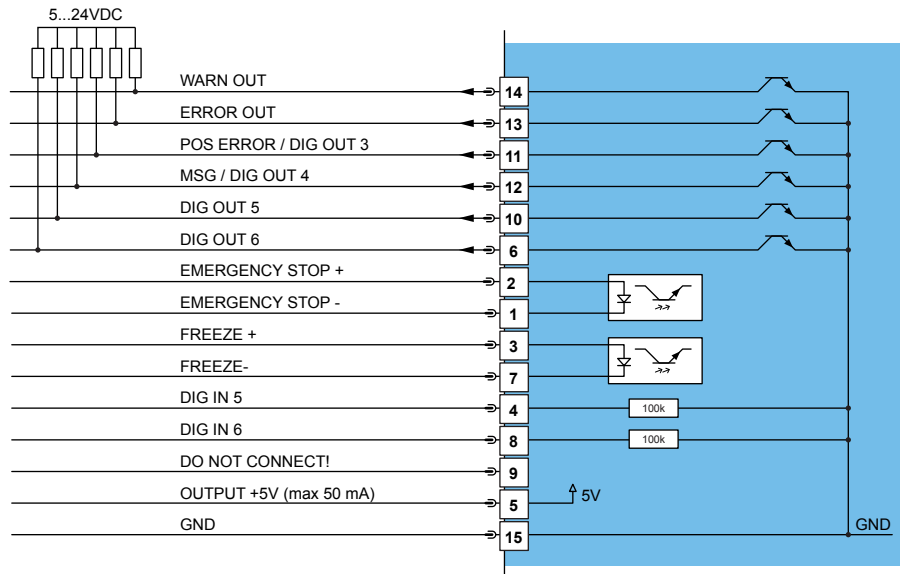

Control Inputs: Stop (active low) / Freeze (active high)

Optical isolated inputs (Input voltage: 0 ... 24V)

- for logical zero: input voltage < 2V
- for logical one: input voltage > 3.5V

Input current: < 20 mA (internally limited to 20 mA)

Update rate: 1.6 ms

Digital Inputs: Dig In 5 / Dig In 6

24VDC inputs, input resistance 100kOhm

- for logical zero: input voltage < 2V
- for logical one: input voltage > 3.5V

Digital Outputs: Pos Error Out / MSG / Error Out / Warn Out / Dig Out 5 / Dig Out 6

Open Collector max 24V / 50 mA

Typical pull-up Resistor R: for V+ = 5V supply: R=150 Ohm/0.25 W
for V+=24V supply: R=820 Ohm / 1W

SYS2

System interface 2

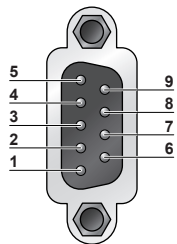

DSUB-9 (m)

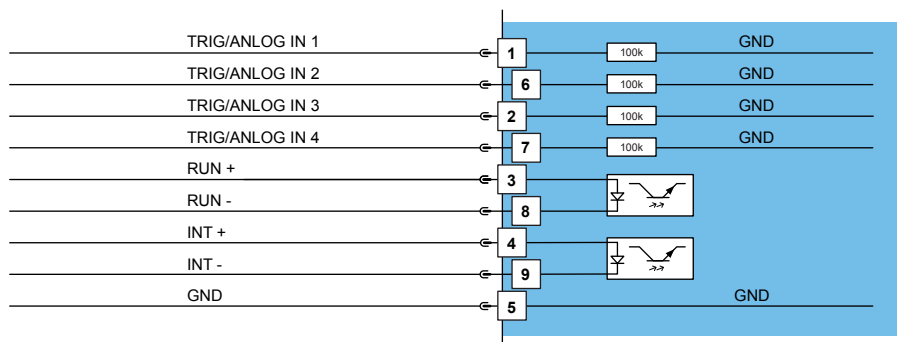

Digital/Analog Input: Trig/Analog IN

Input can be used as analog inputs between 0 ... 10V (10 bit resolution) input resistance 100kOhm or digital inputs (max. 24V, input resistance 100kOhm) for logical zero <2V, for logical one >3.5V

Control Inputs: RUN (active high) / INIT (active high)

Optical isolated 24V inputs

Input voltage: 0 ... 24V

for logical zero <2V
for logical one >3.5V

Input current: < 20 mA (internally limited to 20 mA)

Update rate: 1.6 ms

DP

Profibus DP interface

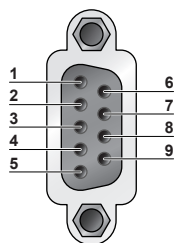

DSUB-9 (f)

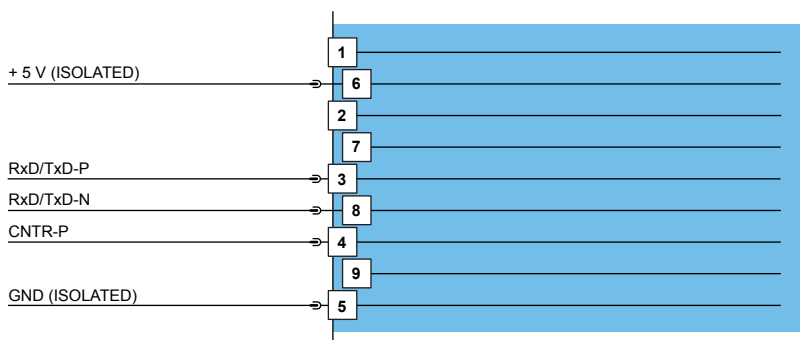

Isolated 5V output: max 50 mA

COM

Com interface

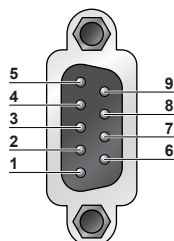

DSUB-9 (m)

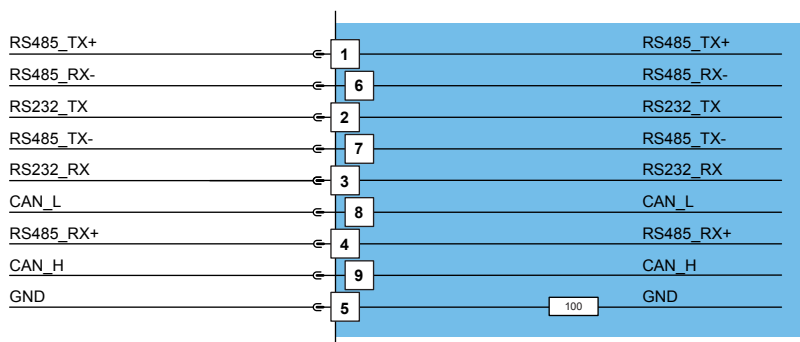

RS232: Configuration on all Drives: use 1:1 connection cable to PC

LED

State display E100

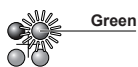

Green

Ready Green:

READY: The system has started correctly

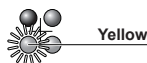

Yellow

Stat A Yellow:

STAT A : Coding for the actual operating state

The display of the various operating states is shown on the last page of this manual.

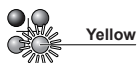

Yellow

Stat B Yellow:

STAT B: Coding for the actual operating state

The display of the various operating states is shown on the last page of this manual.

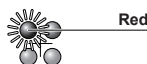

Red

Fault Red:

FAULT: An error has occurred

(In the state ERROR a blink code of the STAT LEDs A and B tells what the actual error is. The blink codes are explained in chapter 'Service' of the user Manual.)

DISPLAY

State display E1001



8 Segment Display

Output of operating states and error codes

Switched-Mode Power Supplies



Item	Description	Part Number
S01-48/300	Switched-Mode Power Supply 48V/300W for Drive Series E100	0150-1941
S01-48/600	Switched-Mode Power Supply 48V/600W for Drive Series E100	0150-1946
S01-72/500	Switched-Mode Power Supply 72V/500W for Drive Serie E1001	0150-1874
S01-72/600	Switched-Mode Power Supply 72V/600W for Drive Serie E1001	0150-1943
S01-72/1000	Switched-Mode Power Supply 72V/1000W for Drive Serie E1001	0150-1872
SM01-300	Mounting part for 300W Switched-Mode Power Supply	0150-3040
SM01-600	Mounting part for 600W Switched-Mode Power Supply	0150-3041

Transformer Supply T01 for E1001

3x230/280/400/480VAC



Item	Description	Part Number
T01-72/420...1500-Multi	Transformer Supply 3x230/280/400/480VAC, 50/60Hz, 420...1500W	see page 532

Control Box B01-04



Item	Description	Part Number
B01-04 230VAC/50Hz	Control Box for E100/E1001-AT/MT (230VAC, incl. cable and connectors)	0150-1930
B01-04 115VAC/60Hz	Control Box for E100/E1001-AT/MT (115VAC, incl. cable and connectors)	0150-1931

COM connection cables and USB-converter



Item	Description	Part Number
RS232 PC config. cabel 2m	for E100/E1001	0150-3009
RS232 PC config. cabel 2m	for E100/E1001/E1100/B1100	0150-3307
RS232 PC config. cabel 2.5m	for E1200/E1400	0150-2143
USB-Serial Converter	USB to 9-pin Serial Converter	0150-3110

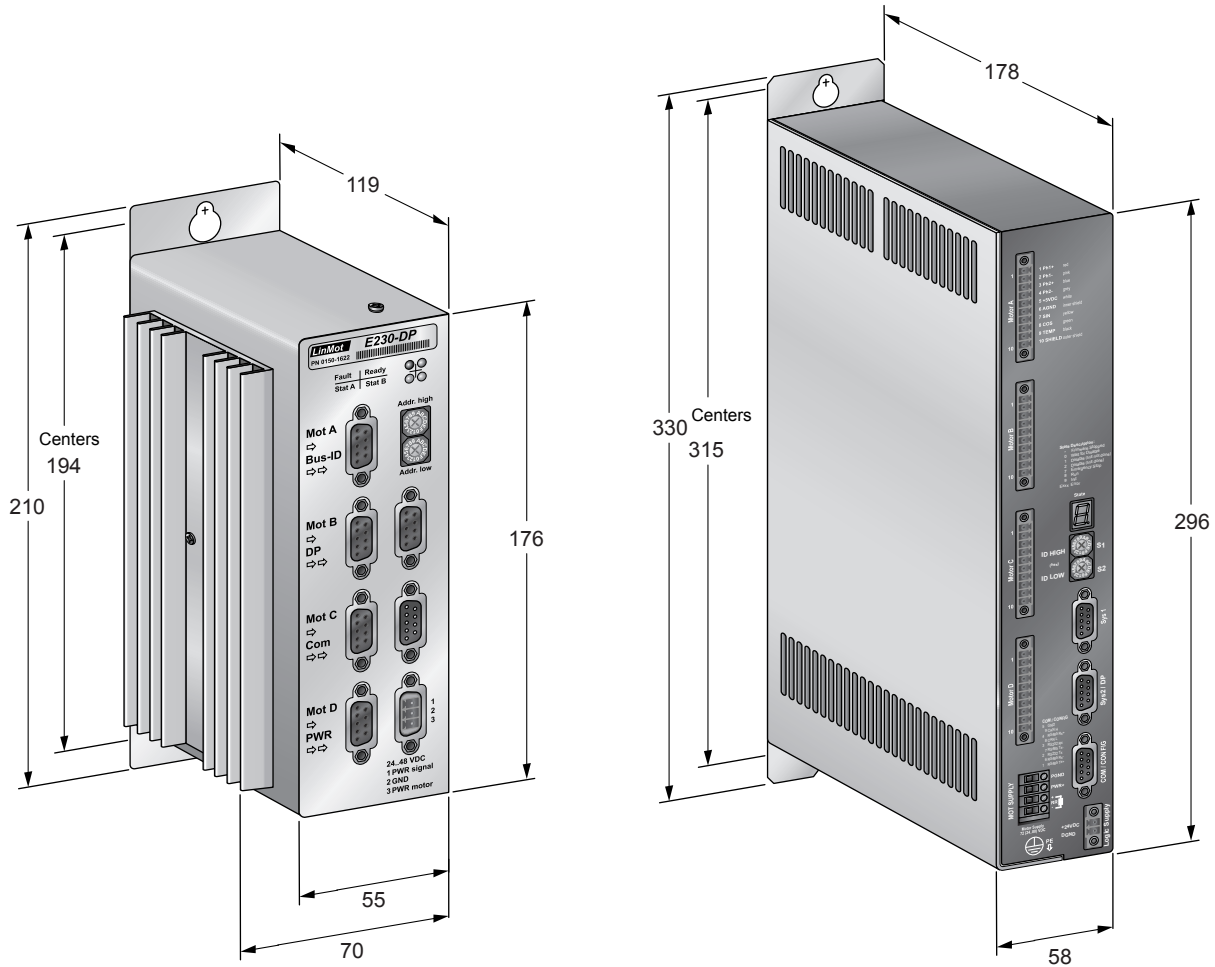

Dimensions in mm

		E100	E200	E400	E1001	E2001	E4001
Interfaces							
Width	mm		70			58	
Height	mm		210			330	
Height without fixings	mm		175			296	
Depth	mm		120			178	
Weight	kg	1.1	1.2	1.3	2.5	2.6	2.7
Protection Class	IP		40			40	
Storage Temperature	°C		-25..70			-25..70	
Operating Temperature	°C		0..50			0..50	
Max. Case Temperature	°C		65			65	
Max. Power Dissipation	W	22	38	70		80	
Distance between Drives	mm		50			50	

Item	Description	Part Number
E100-AT	AnalogTrigger Drive 1 Axis (48V/3A)	0150-1601
E200-AT	AnalogTrigger Drive 2 Axis (48V/3A)	0150-1602
E400-AT	AnalogTrigger Drive 4 Axis (48V/3A)	0150-1604
E1001-AT	AnalogTrigger Drive 1 Axis (72V/8A)	0150-2300
E2001-AT	AnalogTrigger Drive 2 Axis (72V/8A)	0150-2301
E4001-AT	AnalogTrigger Drive 4 Axis (72V/8A)	0150-2303
E100-MT	Multi Trigger Drive 1 Axis (48V/3A)	0150-1611
E200-MT	Multi Trigger Drive 2 Axis (48V/3A)	0150-1612
E400-MT	Multi Trigger Drive 4 Axis (48V/3A)	0150-1614
E1001-MT	Multi Trigger Drive 1 Axis (72V/8A)	0150-2304
E2001-MT	Multi Trigger Drive 2 Axis (72V/8A)	0150-2305
E4001-MT	Multi Trigger Drive 4 Axis (72V/8A)	0150-2307
E130-DP	Profibus DP Drive 1 Axis (48V/3A)	0150-1621
E230-DP	Profibus DP Drive 2 Axis (48V/3A)	0150-1622
E430-DP	Profibus DP Drive 4 Axis (48V/3A)	0150-1624
E1031-DP	Profibus DP Drive 1 Axis (72V/8A)	0150-2316
E2031-DP	Profibus DP Drive 2 Axis (72V/8A)	0150-2317
E4031-DP	Profibus DP Drive 4 Axis (72V/8A)	0150-2319
E100-DN	DeviceNet Drive 1 Axis (48V/3A)	0150-1641
E200-DN	DeviceNet Drive 2 Axis (48V/3A)	0150-1642
E400-DN	DeviceNet Drive 4 Axis (48V/3A)	0150-1644
E1001-DN	DeviceNet Drive 1 Axis (72V/8A)	0150-2312
E2001-DN	DeviceNet Drive 2 Axis (72V/8A)	0150-2313
E4001-DN	DeviceNet Drive 4 Axis (72V/8A)	0150-2315
E100-CO	CanOpen Drive 1 Axis (48V/3A)	0150-1669
E200-CO	CanOpen Drive 2 Axis (48V/3A)	0150-1670
E400-CO	CanOpen Drive 4 Axis (48V/3A)	0150-1672
E1001-CO	CanOpen Drive 1 Axis (72V/8A)	0150-2308
E2001-CO	CanOpen Drive 2 Axis (72V/8A)	0150-2309
E4001-CO	CanOpen Drive 4 Axis (72V/8A)	0150-2311



Servo Drive E1100

Series E1100-RS/-DN/-CO**356****Series E1130-DP****358****Series E1100-GP****360**

Servo Drive E1100

Series E1100 Servo Drives are modular axis drives, with 32-bit position resolution and an integrated power element, for linear motors and rotary drives.

The drives are suitable for simplest, standard, and high-end positioning tasks, across the entire force range of the LinMot product range.



Connection to Machine Drive

The Series E1100 Servo Drives can be actuated by machine controls from any manufacturer or brand, via digital inputs and outputs, RS232 or RS485 serial interface, CanBus CANopen and DeviceNet interfaces, Profibus DP.

For complex motion sequences that are run in an overlaid position drive, B1100 small servo amplifiers are available, with analog velocity or force control and encoder simulation.

Process and Safety Interfaces

Fast process interfaces for direct processing of sensor signals are available as freely programmable analog and digital inputs, a fast trigger input, and a capture input.

The safe pulse inhibitor on Servo Drive with fieldbus interfaces allows safe stoppage of the drives via control signals, per EN 954-1, without interrupting the power supply.

Logic and Power Supply

The Servo Drives have two separate power supplies for the logic and power elements.

In an E-stop and safe stop of the drive, only the power element supply is cut off from the drive. The logic supply and the drive continue to run.

This has the advantage that the drive and linear motor do not need to be reinitialized when the machine is restarted, since all process data, including the current position of the linear motor, are still up to date.

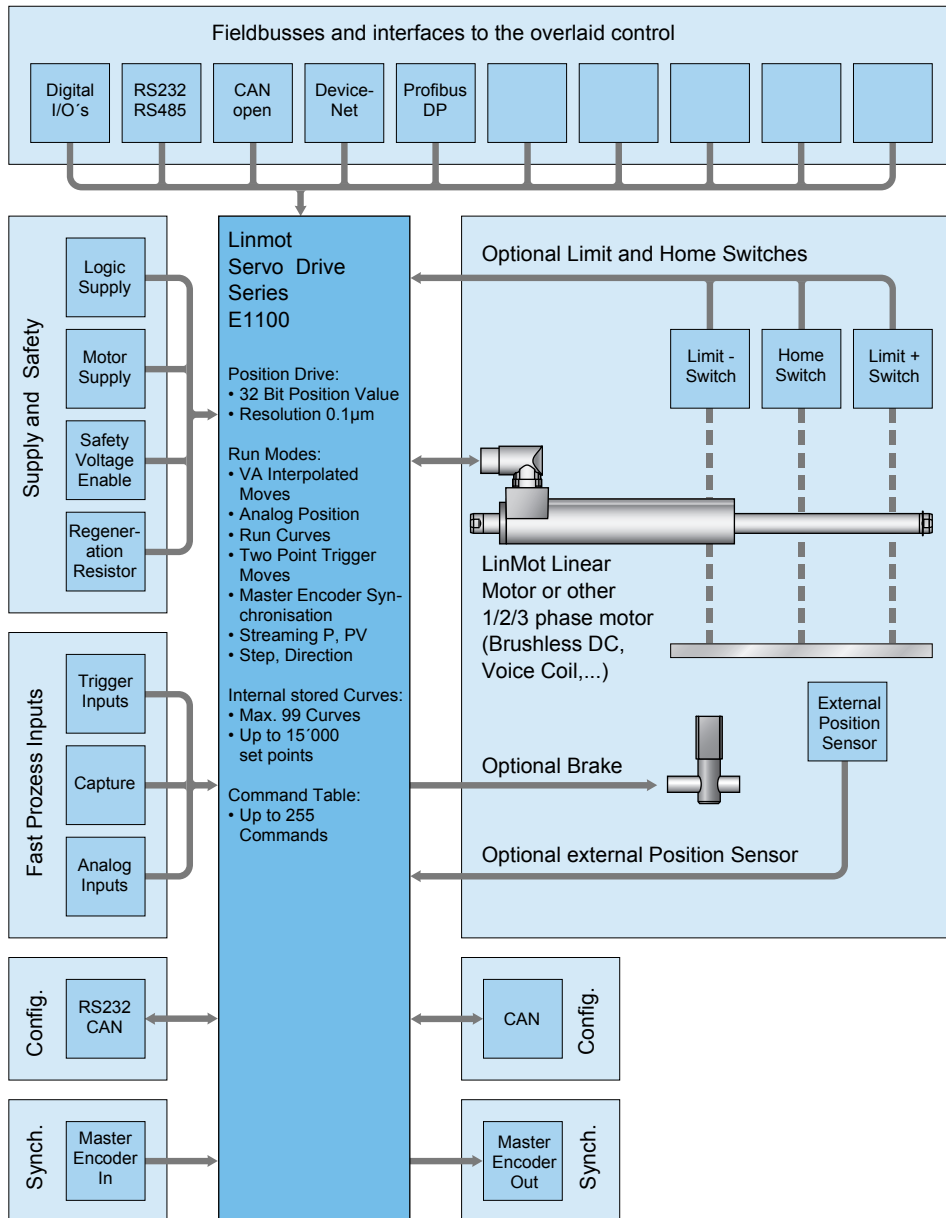

System Integration

Flexible hardware enables control of any 1/2/3-phase motors. Thus, low-power rotary servomotors, such as brushless DC motors, can be integrated in the same controls concept.

Additionally, the drives can be equipped with optional peripherals, such as reference and end stop switches, high-precision external position sensors, or a mechanical holding brake.

Series E1100 Servo Drives have analog and digital inputs and outputs, serial interfaces, fieldbuses. The user is therefore not dependent on the selection of the overlaid drive. An appropriate interface is available, with associated protocols, for any PLC or IPC solution.

With flexibility and a compact form factor, LinMot Series E1100 Servo Drives provide a complete solution for a flexible drive concept in single and multiple axis applications, with linear motors and other actuators.

Technology Functions

Technology functions are functional blocks that provide a complete solution for standard applications and frequently encountered, customer-specific problems. Technology functions can, for example, handle the complete sequence for winding textile yarns or glass fiber cables, or high-precision joining processes with force control can be implemented directly in the drive.

Option: Master Encoder Module

For synchronization to a mechanical master shaft, or a rotating main drive, the Axis (linear motors and rotary motors) can be coupled to an electronic main shaft via the Master Encoder Interface.

The encoder signal from the main shaft can be passed through by the Master Encoder Interface, so that any number of linear motors can be synchronized to the main shaft.

Motor Interfaces

E1100 Servo Drives provide all necessary interfaces to operate linear or rotary motors with optional external peripherals, such as end position and reference switches, a mechanical brake, or a high-resolution external position sensor.

In special applications, two drives can be synchronized with each other using the synchronization interface in master booster or master gantry mode.

Configuration

Parameterization and configuration of the Servo Drive is done via the RS232 interface on the front side, or CANBus for simultaneous configuration of several drives.

LinMot Talk user-friendly PC software is available for configuration. In addition to on-line documentation, LinMot Talk provides extensive debugging tools, such as an oscilloscope and an error inspector, for simple and rapid start-up of the Axis.

Fieldbus drives can also be configured directly by the overlaid control.

Interpolated Moves

Stroke [mm]

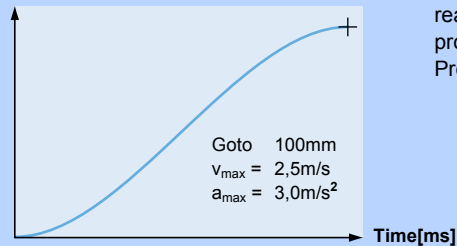

For direct position targets, using absolute or relative positioning, the desired position is reached using acceleration and velocity-limited motion profiles or jerk optimized Bestehorn profiles. Positioning commands can be invoked via the serial interfaces, CANopen, DeviceNet, Profibus or a trigger input.

Stroke range:	±100m
Position Resolution:	0.1µm (32Bit)
Velocity Resolution:	1.0µm/s (32Bit)
Velocity Resolution:	10.0µm/s ² (32Bit)

Time Curves

Stroke [mm]

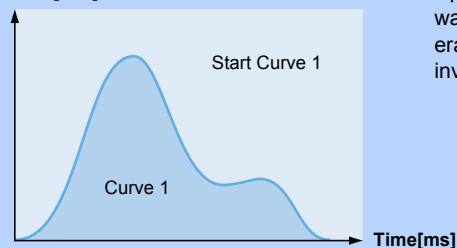

Up to 99 different time curves can be stored Series E1100 drives, with up to 16,000 individual waypoints. The motor can thus travel along time curves of any complexity, such as those generated by CAD programs and stored in the drive (Excel CSV format). The time curves can be invoked via the serial interface, fieldbuses, ETHERNET, or the trigger input.

Stroke range:	±100m
Position Resolution:	0.1µm (32Bit)
Motion profiles:	Max. 99 Time Curves
Curve points:	Max. 16'000 points

Profiled Moves

Stroke [mm]

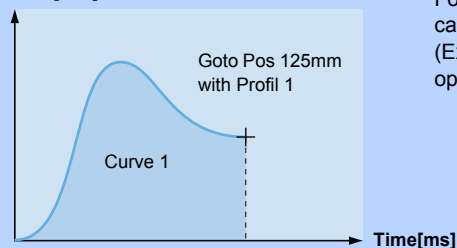

For travel to an absolute position, or shifting by a relative position, any desired motion rules can be stored besides the VA interpolator. They are stored in the drive as motion profiles (Excel CSV format). The positions can be approached, for example, with a sinusoidal motion to optimize power loss, or special reverse optimized motion profiles.

Stroke range:	±100m
Position Resolution:	0.1µm (32Bit)
Motion profiles:	Max. 99 Bewegungsprofile
Curve points:	Max. 16'000 Punkte

Setpoint Streaming

Stroke [mm]

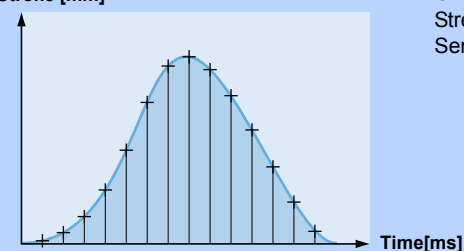

Overlaid NC drives with fieldbus interfaces communicate with the Servo Drives via "Position Streaming". The position and velocity calculated in the overlaid control is transmitted to the Servo Drive cyclically. The P, PV, or PVT mode is available for this transmission.

Position Resolution:	32 Bit
Velocity Resolution:	32 Bit
Interpolator:	3 kHz
cycle times:	2-5ms

Easy Steps

Input 1	Pos 125mm
Input 2	Pos 250mm
Input 3	Curve 1
Input 4	Pos -30mm
Input 5	Pos +12,5mm
Input 6	Curve 2
Input 7	Pos 2mm
Input 8	Pos -12,5mm

With the Easy Steps function, up to 8 positions or independent travel commands can be stored on the drive, and addressed via 8 digital inputs or fieldbus interfaces/ETHERNET.

Digital inputs:	max. 8
Interface:	X4
Resolution:	10 Bit
Scanning rate:	330µsec

Command Table

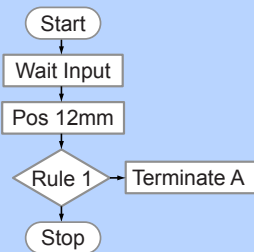

Entire motion sequences with up to 256 individual motion commands can be stored in the Command Table. This is primarily advantageous if complete motion sequences need to be executed very quickly, without dead time from the overlaid drive. In the Command Table, the programmer has access to all motion commands, internal parameters, and digital inputs and outputs.

Commands:	max. 256
Cycle time:	330µsec

Master Encoder Synchronization (MT)

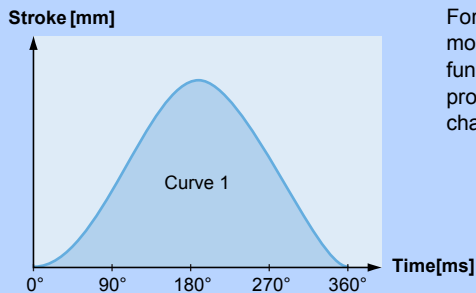

For synchronization to an external main or master shaft, the linear motor travels along the motion profiles stored in the drive, at the machine speed (machine angle 0...360°). Using this function, mechanical cam discs can be replaced with highly dynamic linear motors. The motion profiles can be freely defined, and the correct motion profile can be invoked during product changeover with no changeover time.

Motion profiles	Max. 99 curve profiles
Curve points:	Max. 16'000 points
Encoder Counter:	32 Bit
Encoder Input:	A/B/Z (RS422)
Max. counting frequency	Max. 4.5 MHz

Belt Synchronization

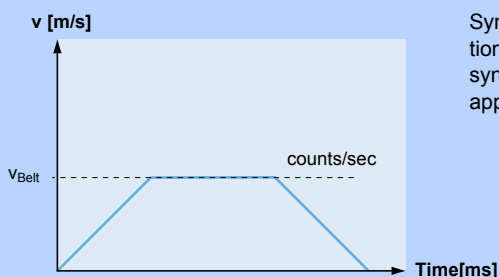

Synchronization to a belt speed can be done using the Master Encoder Interface or Step/Direction/Zero interface. Applications such as the "flying saw", synchronous loading or unloading, synchronous filling or labeling of bottles or containers on a conveyor belt, and many other applications can be implemented in this way.

Encoder Counter:	32 Bit
Encoder Input:	A/B/Z (RS422), max. 5 MHz
	STEP/DIR/ZERO
Max. counting frequency	Max. 4.5 MHz

Position Indexing

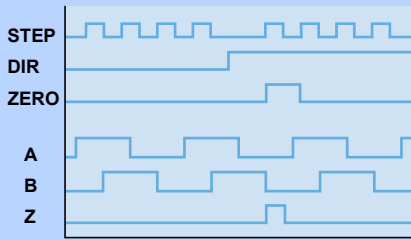

In position indexing, the linear motor is controlled like a stepper motor, using Step/Dir/Zero, or A/B/Z signals. The step distance is freely programmable from $1.5 \times 10^{-6} \mu\text{m}$ to 3.275mm./ step. The input signal can be used directly as the target position, or it can be filtered by the VA interpolator.

Operating Modes:	Step/Dir/Zero, A/B/Z
Inputs:	differential RS422 (X10)
Step distance:	$1.5 \times 10^{-6} \mu\text{m}$3.275mm, 32 Bit
Max. counting frequency:	4.5 MHz

Master-Booster Synchronisation

Master-Booster Synchronisation

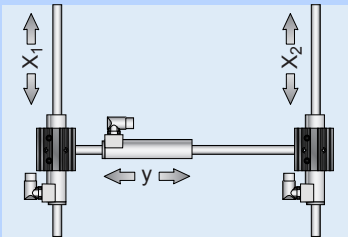

Using master-slave synchronization, two linear motors can be synchronized via a serial communications connection between two drives, so that the overlaid drive can control them as a single axis.

Master Booster Synchronization

Master booster synchronization is used to double the force when two motors are mechanically rigidly connected to each other.

Master-Gantry Synchronisation

Master-Gantry Synchronisation

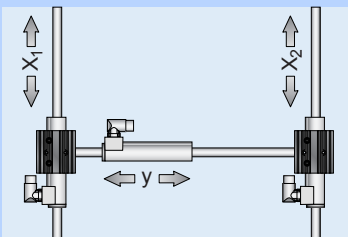

Using master-slave synchronization, two linear motors can be synchronized via a serial communications connection between two drives, so that the overlaid drive can control them as a single axis.

Master Gantry Synchronization

Master gantry synchronization is used for portal designs with two parallel Axis at different locations.

Analog Position

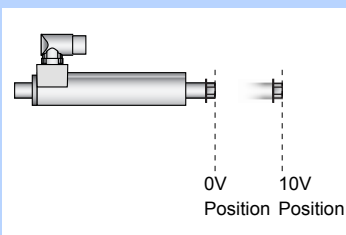

For an analog position target, the linear motor travels to a position proportional to the input voltage. The position is either scanned continuously, or only after a rising edge of the trigger signal. In order to prevent uncontrolled jumps in position, the motor travels to the positions with a programmable maximum acceleration and velocity (VA interpolator).

Inputs:	Analog Input (X4.4)
Voltage range:	0-10VDC
Resolution:	10 Bit
Scanning rate:	330µsec

Easy Steps Parameter Scale

Maximum Force [0...10V => 0...100%]

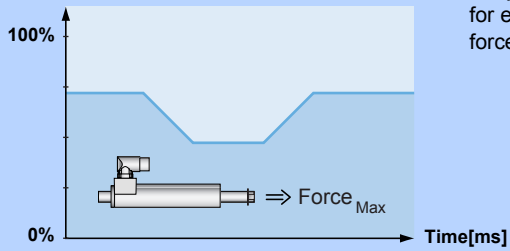

Easy Steps provide the ability to parameterize internal parameters using two analog inputs. If, for example, the maximum motor current is read at an analog input, then the maximum motor force can be provided as analog for freely programmable joining processes.

Inputs:	2 x Analog (X4.4, X4.7)
Voltage range:	0-10VDC
Resolution:	10 Bit
Resolution	330µsec

Winding Application

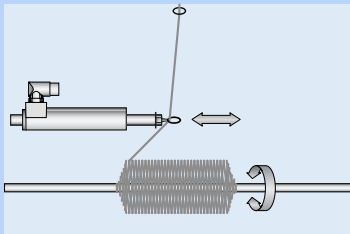

For winding textile yarns, glass fiber optics, or wires, a complete functional block is available that controls the entire sequence of a complete winding process.

Closed Loop Force Control

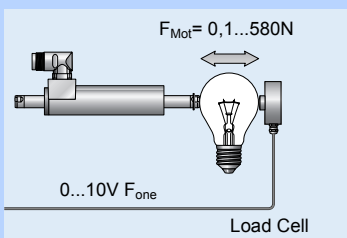

Using the Force Control technology function, precise joining processes can be implemented reliably and reproducibly with high-precision force control. For force control, the current motor force is measured with a load cell and controlled in the drive. Joining process or quality checks with high requirements for applied force can be implemented.

Analog Input:	0-10V
Resolution:	10 Bit
Min. Force Resolution:	0.1N

LinMot Talk

LinMot Talk configuration software is a Windows-based interface that supports the user during start-up and configuration of the LinMot Servo Drives. The software has a powerful, modular, graphical interface that covers all the tasks surrounding the LinMot Servo Drive. Great emphasis was placed on a high level of user-friendliness during development.

In addition to start-up, LinMot Talk can also be used for training purposes and for actuation via serial interfaces, fieldbuses, or industrial ETHERNET. Using the integrated Control Panel, the user has direct access to control and status words, as well as all commands that are invoked for operation by the overlaid control. The user learns the meaning of the control and status words easily, and can get to know the individual commands in the Motion Command Interface.

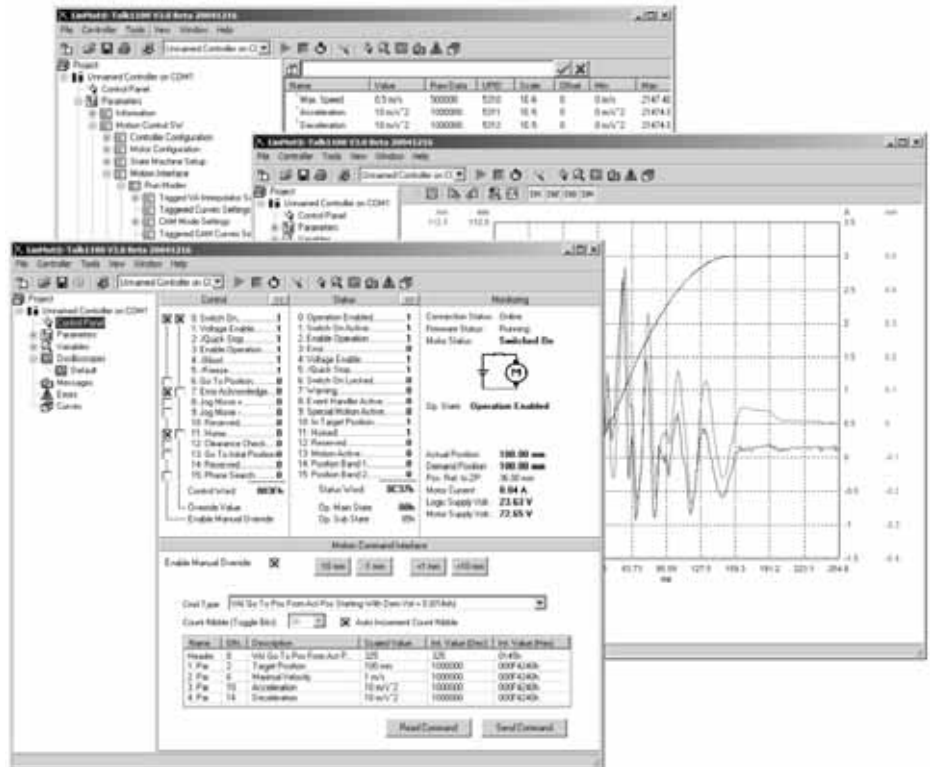

Start-up and Analysis Tools

Using the LinMot Talk PC interface, LinMot Servo Drives are configured. Additionally, the drives can be monitored during operation with the machine running, and the current motion sequences, as well as earlier warnings and error messages, can be analyzed in detail (monitoring).

Single or Multiple Axis Configuration

For start-up and monitoring, the Servo Drive is connected to a PC via the RS232 interface on the front or via CAN Bus. If the connection to the PC is made via USBSCAN converter (see accessories,) then up to 16 Axis can be configured and monitored simultaneously.

Online Help & Documentation

Using the multilingual Online Help, the user can find useful information about the individual parameters and their functionality. All manuals and installation instructions can then be called up on the PC, after LinMot Talk is installed, via the Windows Start Menu, or they can be directly generated in HTML format.

Parameterization

Using the "Parameter Inspector," the drives are parameterized in a simple manner. The user has a wide range of adjustments available for operating modes, error management, warning messages, and regulating parameters. Entire parameter sets can be stored, loaded, and printed out.

The "Curve Inspector" allows creation of motion profiles. In addition, existing curves can be loaded, stored, edited, combined, and printed out. Further, complex motion sequences can be generated as desired in MS Excel, and loaded into the drive.

Optimization

The integrated 8-channel oscilloscope helps the user during start-up and optimization of the drive system. Internal variables, such as the target and actual position, can be shown in real time on the screen, and then printed out. The displayed data can be stored in CSV format for further processing in MS Excel, or stored for documentation purposes.

Monitoring

The user has many tools available for monitoring and analysis of the drive. Both current warnings and fault messages, and older fault messages stored in non-volatile memory, state changes, and many other pieces of information can be obtained.

Internal variables, drive parameters, inputs, and outputs can be combined as desired and display cyclically.

Using the oscilloscope, internal parameters can be charted when warning and fault messages occur.

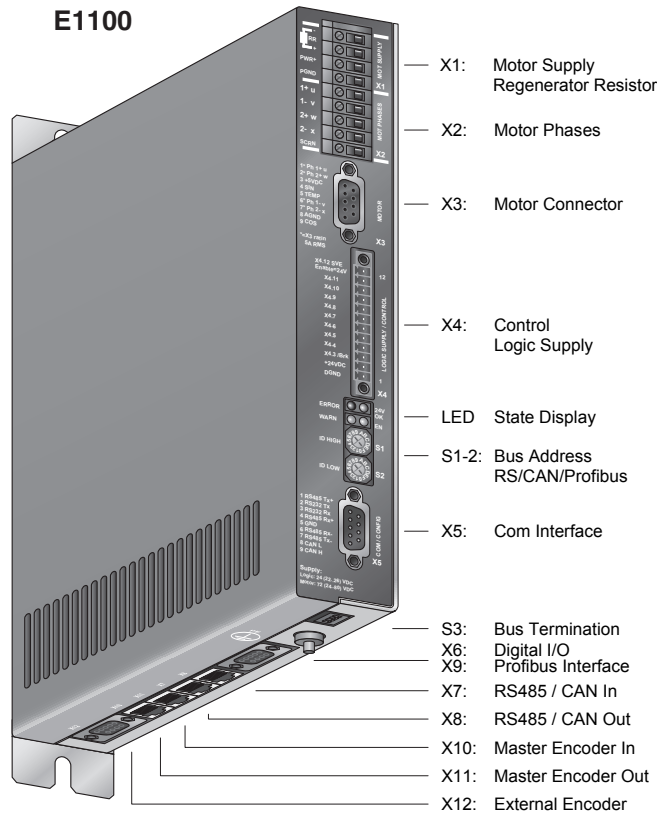

		E1100-RS	E1100-CO	E1100-DN	E1100-DP	E1100-GP
Interfaces						
X1	Motor Supply Regeneration Resistor	●	●	●	●	●
X2	Motor Phases	●	●	●	●	●
X3	Motor Connector	●	●	●	●	●
X4	Control / Logic Supply	●	●	●	●	●
X5	COM Interface	RS232	●	●	●	●
		RS485	●	●	●	●
		CAN	●	●	●	●
X6	Digital I/O					●
X7	RS485 / CAN In	●	●	●	●	
X8	RS485 / CAN Out	●	●	●	●	
X9	Profibus Interface				●	
X10	Master Encoder In	●	●	●	●	●
X11	Master Encoder Out	●	●	●	●	●
X12	External Encoder (D-Sub 9)	●	●	●	●	●
X13	External Encoder (D-Sub 15)					
LED	State Display	●	●	●	●	●
S1	Bus Address RS/CAN/ETH High	●	●	●	●	●
S2	Bus Address RS/CAN/ETH Low	●	●	●	●	●
S3	Bus Termination	●	●	●	●	●

E1100-RS
E1100-RS-HC
E1100-RS-XC

E1100-DN
E1100-DN-HC
E1100-DN-XC

E1100-CO
E1100-CO-HC
E1100-CO-XC

RS 232

RS 485

DeviceNet

CANopen

- ✓ Absolute & Relative Positioning
- ✓ Travel Along Time Curves
- ✓ Positioning using Motion Profiles
- ✓ Internally stored Motion Commands
- ✓ Internally stored Motion Sequences
- ✓ Master Encoder Synchronization
- ✓ Synchronization to Belt Speed
- ✓ Step and Direction Interface
- ✓ Position Streaming
- ✓ Master-Slave Synchronization
- ✓ Analog Position Target
- ✓ Analog Parameter Scaling
- ✓ Winding Function Block
- ✓ Force Control Technology Function
- ✓ Customer-Specific Functions

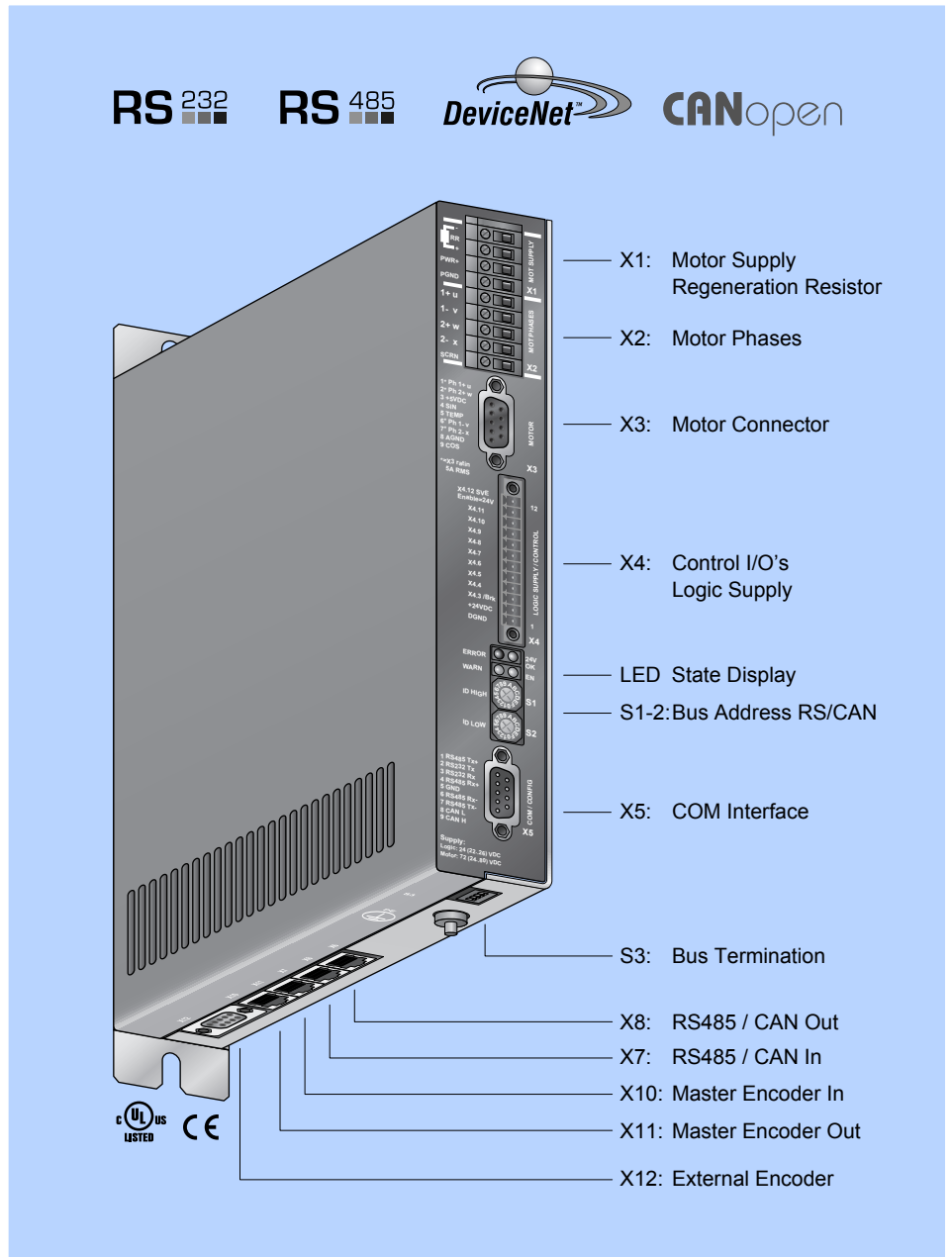

LinRS Serial Interface

The LinMot Series E1100-RS Servo Drives support the LinRS serial communication protocol. LinRS is a proprietary protocol for actuating LinMot Servo Drives via the RS 232, RS 422, and RS 485 interfaces.

If the drive is actuated by the overlaid control via the serial interface, then this is configured from the PC via CANBus. The USBSCAN converter (item no. 0150-3134), supported by LinMot Talk, is used for this.

Adjustable Baud rates: 9.6-115.2kBaud

CANopen

LinMot CO drives, with integrated CANopen interface, support the CiA DS301 communication profile.

The following resources are available: 3 T_PDO, 3 R_PDO, 1 T_SDO, 1 R_SDO

The following protocols are supported by the CO drives:

- NMT Error Control (Nodeguarding Protocol or HeartBeat Protocol)
- PDO (Transmission type 254 and 1)
- SDO Upload and Download - NMT (Start, Stop, Enter PreOp, Reset Node, Reset Communication)
- Boot-Up Message

DeviceNet

Series E1100-DN drives feature an integrated DeviceNet interface. With the DeviceNet interface, even complicated motion sequences can be realized with the highest possible flexibility.

The drive can be actuated and monitored via the DeviceNet connection.

E1100-DN are UCMM Group 3-capable slaves, and support polled IO runtime data transfer

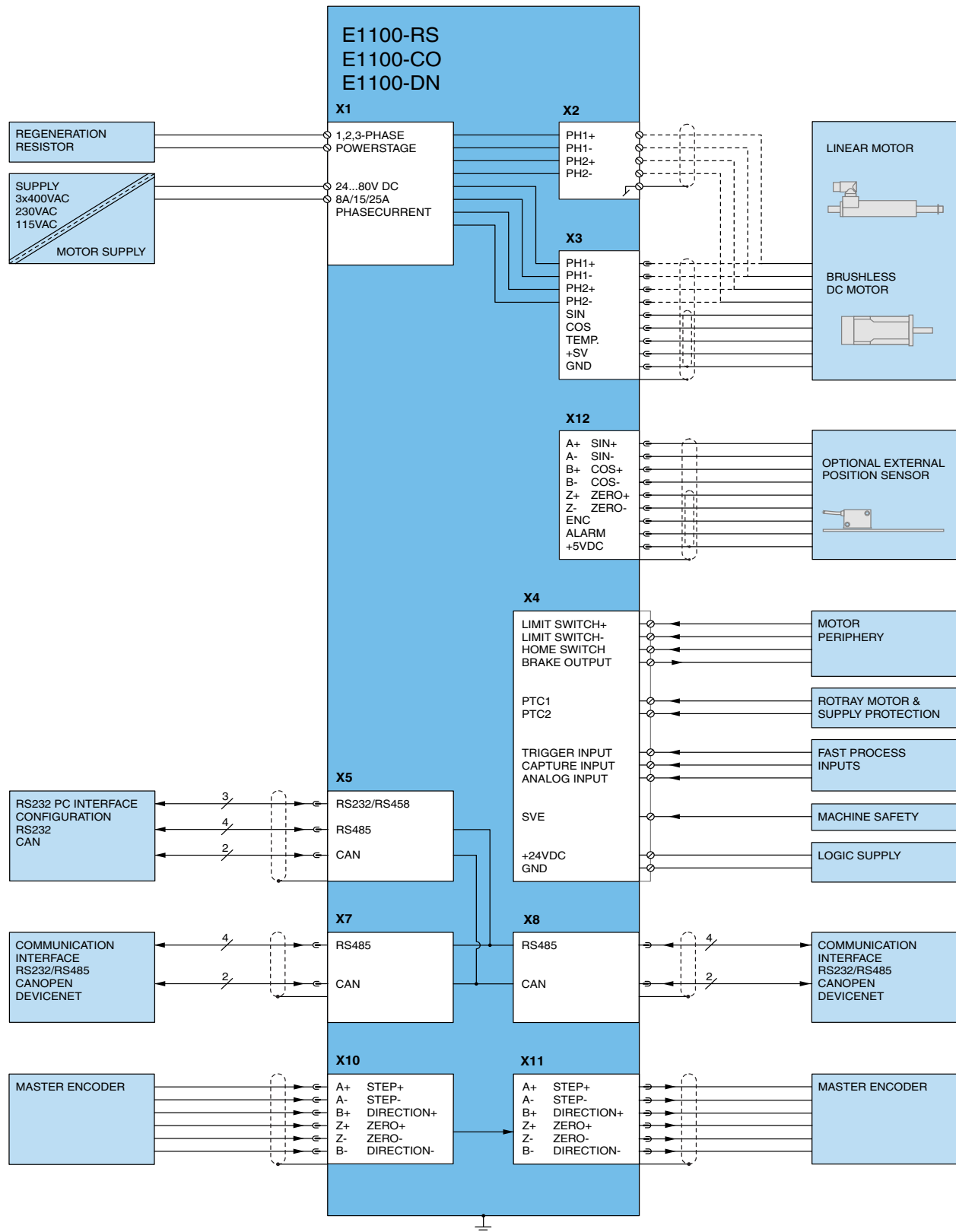

Item	Description	Part Number
E1100-RS	RS232/485 Drive (72V/8A)	0150-1677
E1100-RS-HC	RS232/485 Drive (72V/15A)	0150-1678
E1100-RS-XC	RS232/485 Drive (72V/25A)	0150-1862
E1100-CO	CANopen Drive (72V/8A)	0150-1681
E1100-CO-HC	CANopen Drive (72V/15A)	0150-1682
E1100-CO-XC	CANopen Drive (72V/25A)	0150-1683
E1100-DN	DeviceNet Drive (72V/8A)	0150-1679
E1100-DN-HC	DeviceNet Drive (72V/15A)	0150-1680
E1100-DN-XC	DeviceNet Drive (72V/25A)	0150-1863

E1130-DP
E1130-DP-HC
E1130-DP-XC

- ✓ Absolute & Relative Positioning
- ✓ Travel Along Time Curves
- ✓ Positioning using Motion Profiles
- ✓ Internally stored Motion Commands
- ✓ Internally stored Motion Sequences
- ✓ Master Encoder Synchronization
- ✓ Synchronization to Belt Speed
- ✓ Step and Direction Interface
- ✓ Position Streaming
- ✓ Master-Slave Synchronization
- ✓ Analog Position Target
- ✓ Analog Parameter Scaling
- ✓ Winding Function Block
- ✓ Force Control Technology Function
- ✓ Customer-Specific Functions

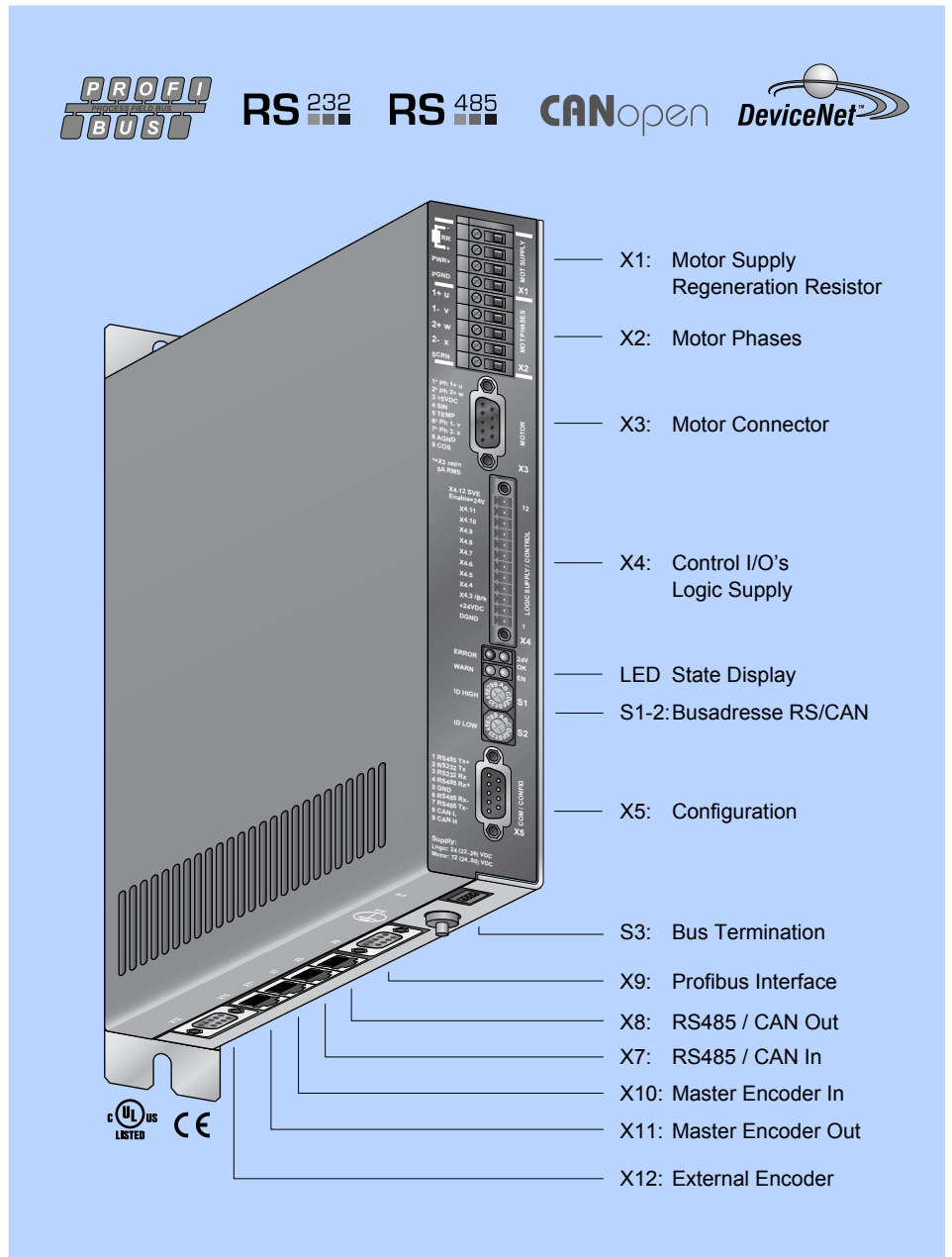

Profibus DP

DP Servo Drives feature an integrated PROFIBUS-DP interface. PROFIBUS-DP provides the user with a standardized fieldbus interface for rapid data interchange between the Servo Drive and the overlaid control.

With fast data transfer and command initiation, as well as simple system integration, the Profibus drives are the ideal solution for applications with motions and sequences that change frequently, such as are required, for example, in flexible machines and systems with automatic format changes.

The PROFIBUS-DP interface supports all Baud rates from 9.6 Kbits/s to 12 Mbit/s. The maximum net data quantity exchanged in cyclical data traffic is 64 bytes per cycle. The smallest achievable bus cycle time is 100 µs.

The structure and scope of cyclical data can be collected from any individual data modules into an overall data quantity when planning the system.

A GSD device master file is provided for open planning in conformance with the PROFIBUS-DP standard.

The 9-pole Profibus connector on the front side provides power for an external bus termination. A positive directional control signal is provided to control repeaters or optical fibers.

All signals on the PROFIBUS connector are galvanically separated.

The PROFIBUS-DP address is set by two hex code switches (ID1 and ID2).

All addresses permitted by the standard are supported (0..125).

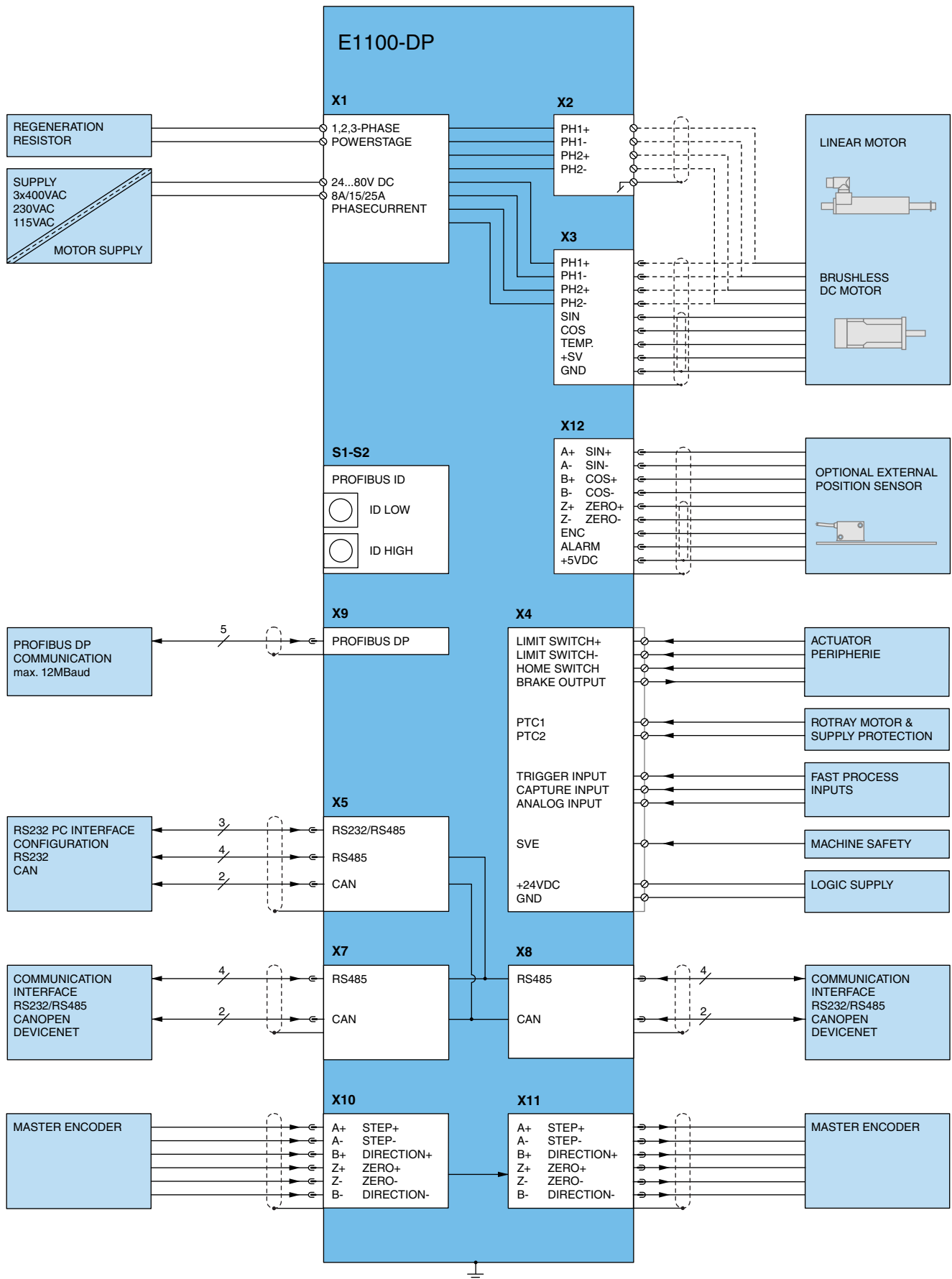

Item	Description	Part Number
E1130-DP	Profibus DP Drive, (72V/8A)	0150-1667
E1130-DP-HC	Profibus DP Drive, (72V/15A)	0150-1668
E1130-DP-XC	Profibus DP Drive, (72V/25A)	0150-1861

E1100-GP
E1100-GP-HC
E1100-GP-XC

RS 232

RS 485

CANopen

DeviceNet™

- ✓ Absolute & Relative Positioning
- ✓ Travel Along Time Curves
- ✓ Positioning using Motion Profiles
- ✓ Internally stored Motion Commands
- ✓ Internally stored Motion Sequences
- ✓ Master Encoder Synchronization
- ✓ Synchronization to Belt Speed
- ✓ Step and Direction Interface
- ✓ Position Streaming
- ✓ Master-Slave Synchronization
- ✓ Analog Position Target
- ✓ Analog Parameter Scaling
- ✓ Winding Function Block
- ✓ Force Control Technology Function
- ✓ Customer-Specific Functions

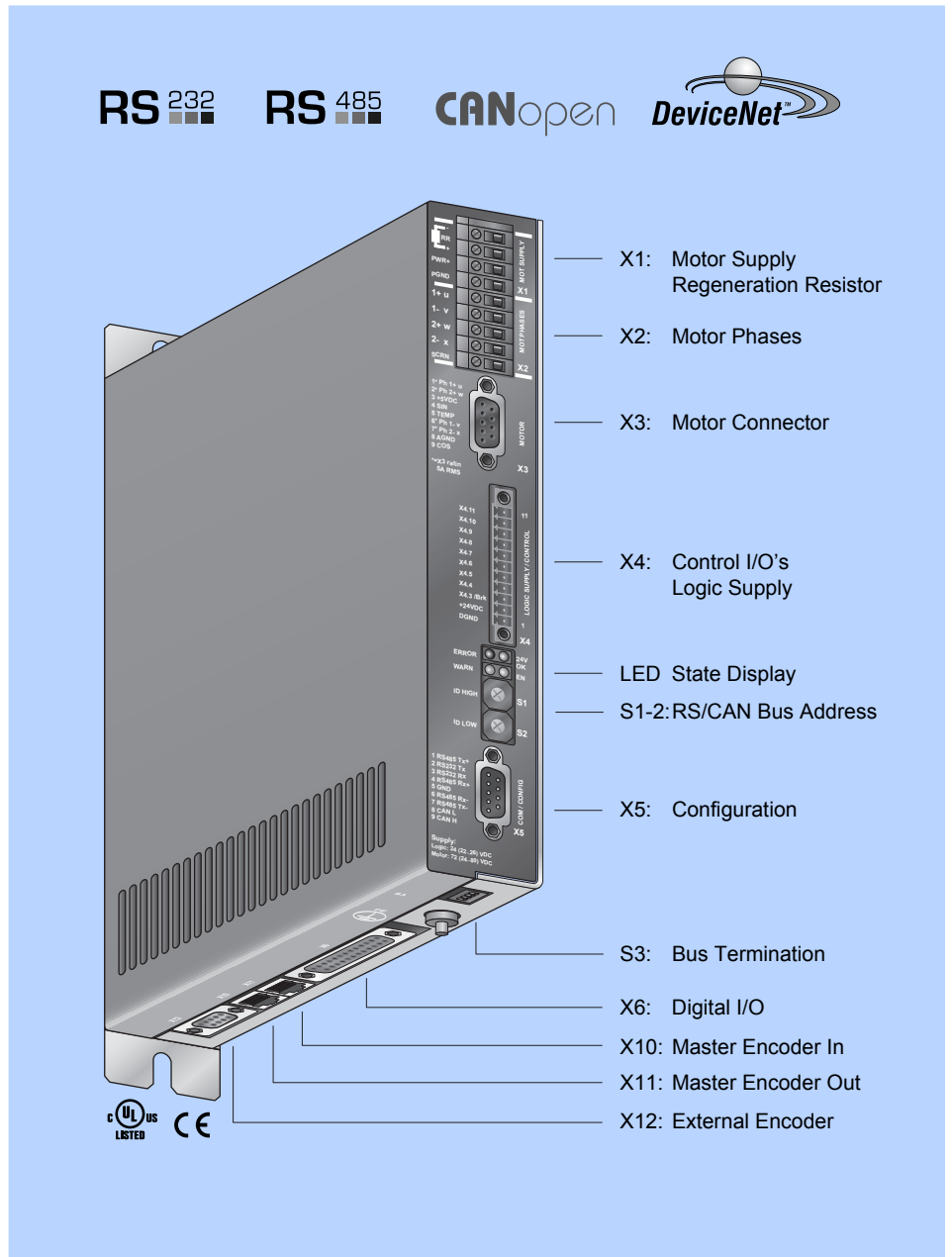

General Purpose Drive

Series E1100-GP drives are multifunctional Servo Drives, on which the firmware from the following drives can be installed:

- Series E1100-RS
- Series E1100-CO
- Series E1100-DN

All functions of the drives listed above, except for safe pulse inhibitors (X4.12) are available in the Series E1100-GP Servo Drives.

For actuation by an overlaid drive, the following digital, serial, and fieldbus interfaces are available:

- LinRS via RS232, RS485 and RS422
- CANopen - DeviceNet

In addition to actuation via serial interfaces and fieldbuses, Series E1100-GP drives can use direct addressing of up to 256 commands in the Command Table, via 8 digital inputs (X6).

Even complex drive tasks and complete, automated sequences can be controlled using simple digital signals.

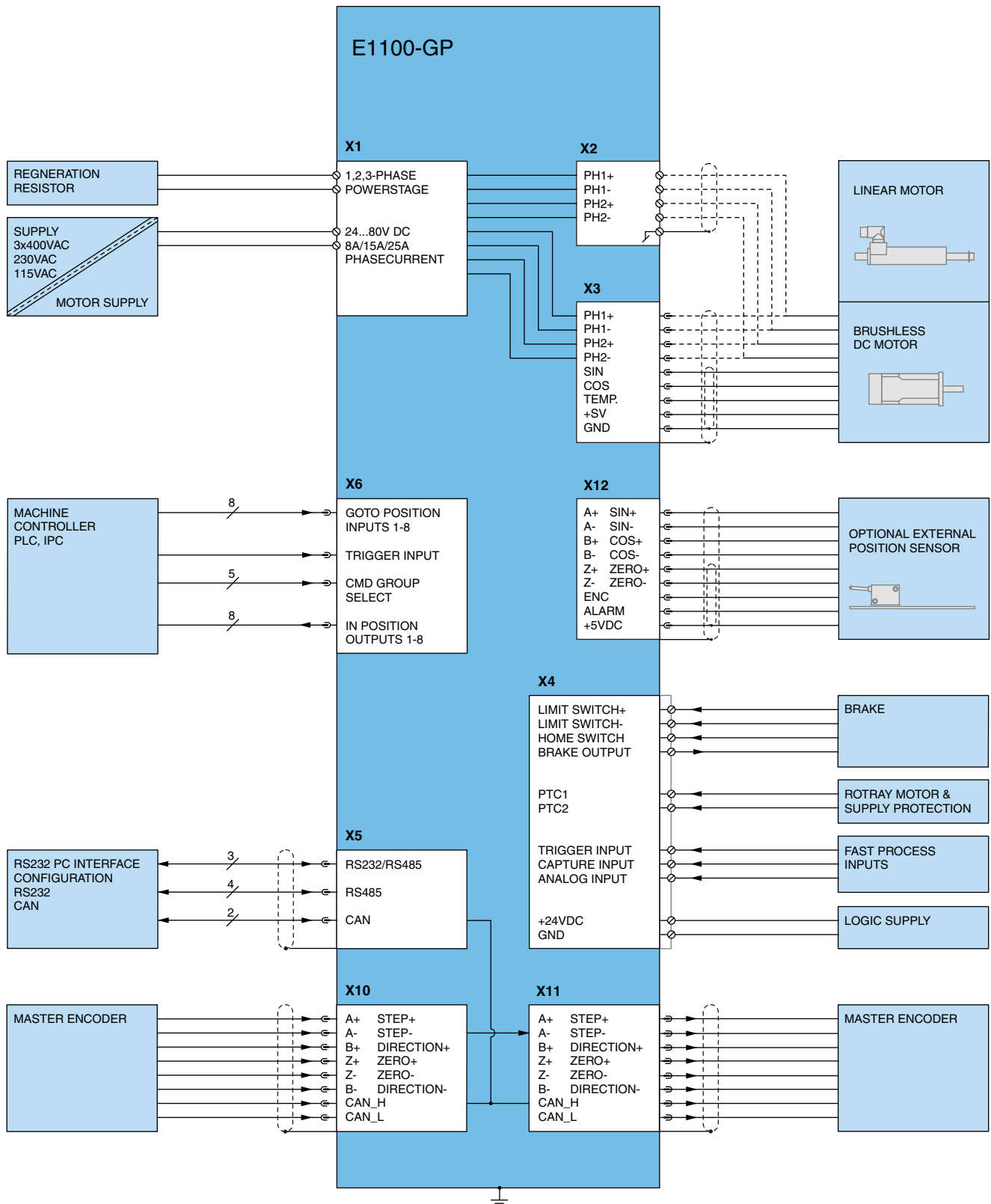

Item	Description	Part Number
E1100-GP	General Pupose (72V/8A)	0150-1665
E1100-GP-HC	General Pupose (72V/15A)	0150-1666
E1100-GP-XC	General Pupose (72V/25A)	0150-1864

X1 Motor Supply / Regeneration Resistor

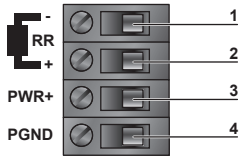

Screw Terminals
2.5 mm² (AWG14)

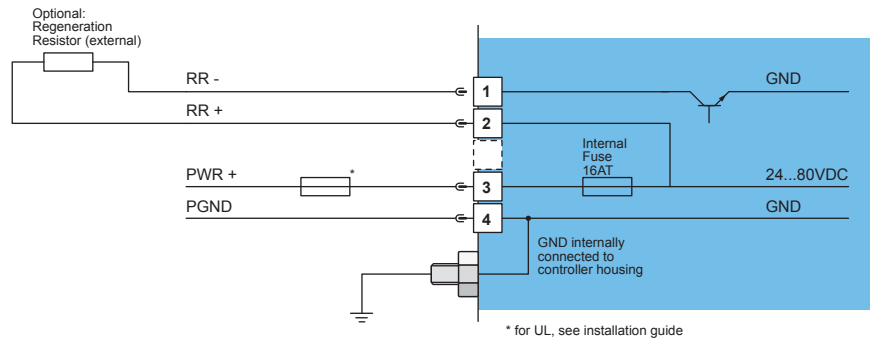

Motor Supply:

Motor Supply Voltage 24...80VDC.
Absolute max. Rating 72VDC + 20%



If motor supply voltage is exceeding 90VDC, the drive will go into error state

X2 Motor Phases

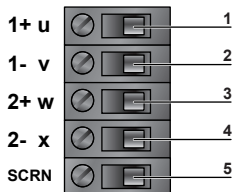

Screw Terminals
1.5-2.5mm²
(AWG16-14)

Nr.	Designation	LinMot Linear Motor	Color	3-Phase-Motor
1	PH1+ /U	Motor Phase 1+	red	Motor Phase U
2	PH1- /V	Motor Phase 1-	pink	Motor Phase V
3	PH2+ /W	Motor Phase 2+	blue	Motor Phase W
4	PH2- /	Motor Phase 2-	grey	
5	SCRN	Shield		

- If the RMS current is not higher than 5Arms, respectively 7.5Apeak, the phases can be connected to X3.
- Do NOT connect X2 and X3.

X3 Motor

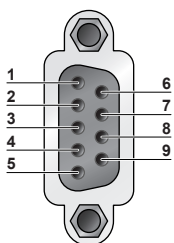

DSUB-9

Nr	LinMot Linear Motor	3-Phase-Motor
1	Motor Phase 1+	Motor Phase U
2	Motor Phase 2+	Motor Phase W
3	+5VDC	
4	Sine	Hall U
5	Temperature	Hall W
6	Motor Phase 1-	Motor Phase V
7	Motor Phase 2-	
8	AGND	
9	Cosine	Hall V
Case	Shield	

- Use X2 for motor phase wiring if phase current exceeds 5Arms or 7.5Apeak
- Use +5V (X3.3) and AGND (X3.8) only for motor internal Hall Sensor supply (max. 100mA)
- Do NOT connect AGND (X3.8) to ground or earth!

Motor Motor wiring

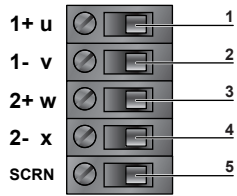

X2: Screw Terminals

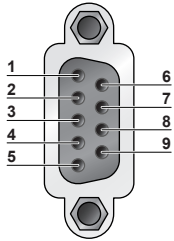

X3: DSUB-9 (f)

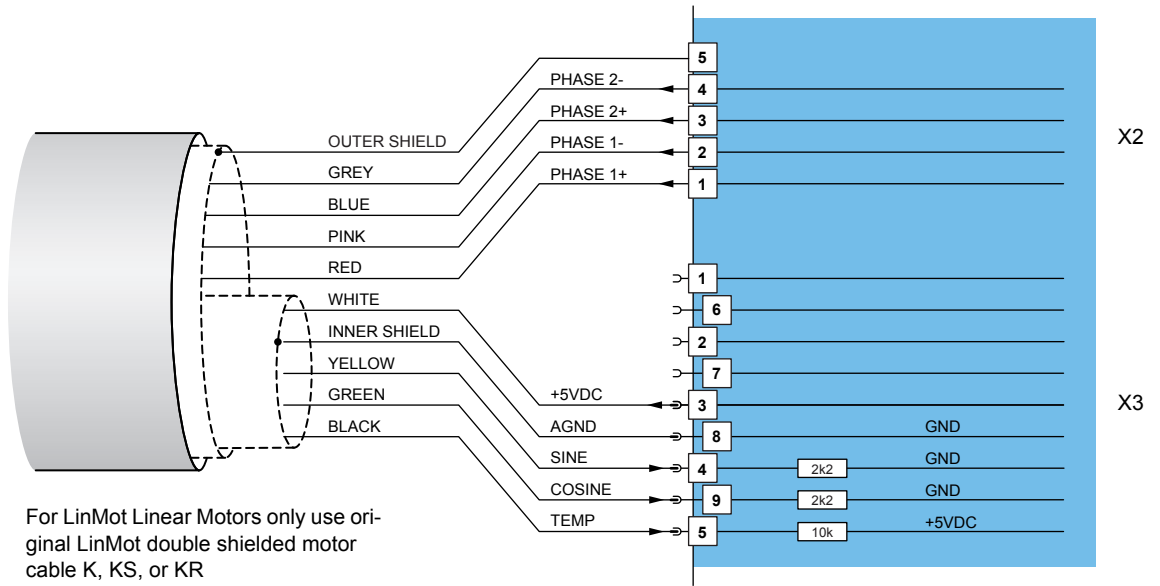

Motor Motor wiring for phase current below 5Arms and below 7.5Apeak

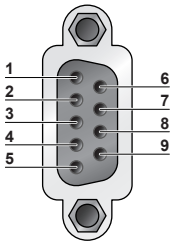

X3: DSUB-9 (f)

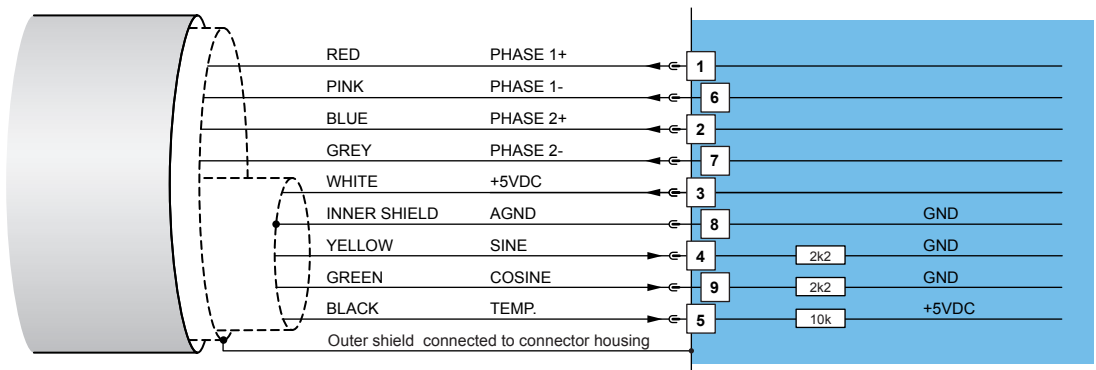

S1-3 Address Selectors / Bus Termination



Switch	Function	Notes
S1	Bus ID High (0...F)	HEX-Switches for Bus ID address range 0.255
S2	Bus ID Low(0...F)	
S3	Switch 1: RS232 "off" / RS485 "on"	Select serial RS23 or RS485
	Switch 2: RS485 Termination on/off	
	Switch 3: CAN Termination on/off	
	Switch 4: Bus Interface on/off	Factory settings: all switches "off"

X4: 12pin

Control / Supply E1130-DP, E1100-CO, E1100-DN, E1100-RS

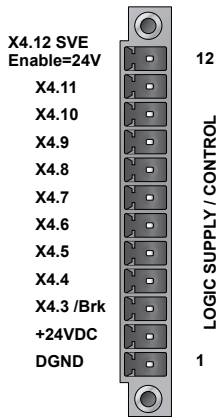

Phoenix MC1,5/12-STF-3,5
0.25-1.5mm² (AWG24-16)

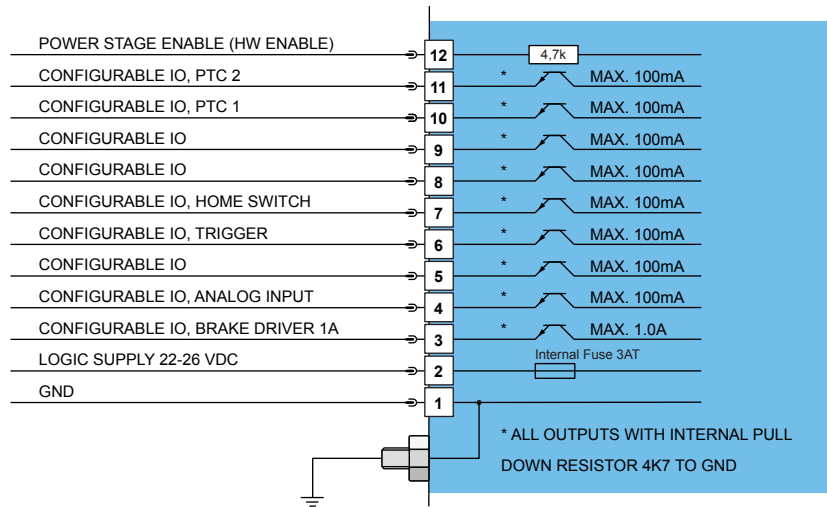

X4: 11pin

Control / Supply E1100-GP

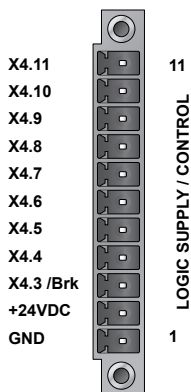

Phoenix MC1,5/11-STF-3,5
0.25-1.5mm² (AWG24-16)

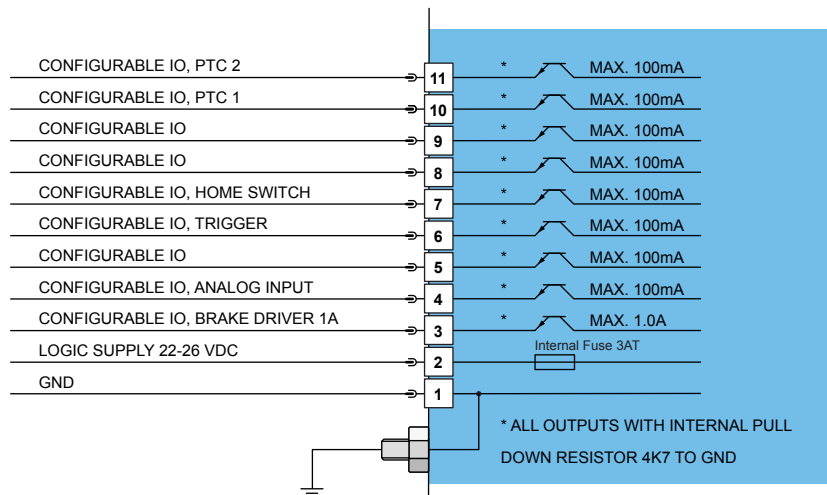

No		Description	
12	Input	Safety Voltage Enable	Power Stage Enable (HW Enable)
11	I/O	X4.11	Configurable IO, PTC 2
10	I/O	X4.10	Configurable IO, PTC 1
9	I/O	X4.9	Configurable IO
8	I/O	X4.8	Configurable IO
7	I/O	X4.7	Configurable IO, Home Switch
6	I/O	X4.6	Configurable IO, Trigger
5	I/O	X4.5	Configurable IO
4	I/O	X4.4	Configurable IO, Analog Input
3	I/O	X4./Brk	Configurable IO, Brake Driver 1A
2	+24VDC	Supply	Logic Supply 22-26 VDC
1	GND	Supply	Ground

Inputs	24V / 1mA
Outputs	24V / max.100mA
Brake Output (X4.3)	24V / max.1.0A
Sample Rate	Inputs/Outputs 1ms, Trigger Input 0.315msec
Supply	24VDC / typ. 400mA / max. 2.1A (if all outputs "on" with max. load.)
Wiring	0.25-1.5mm ² (AWG24-16)

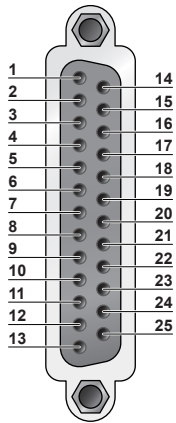

X6: DSUB-25 (f)

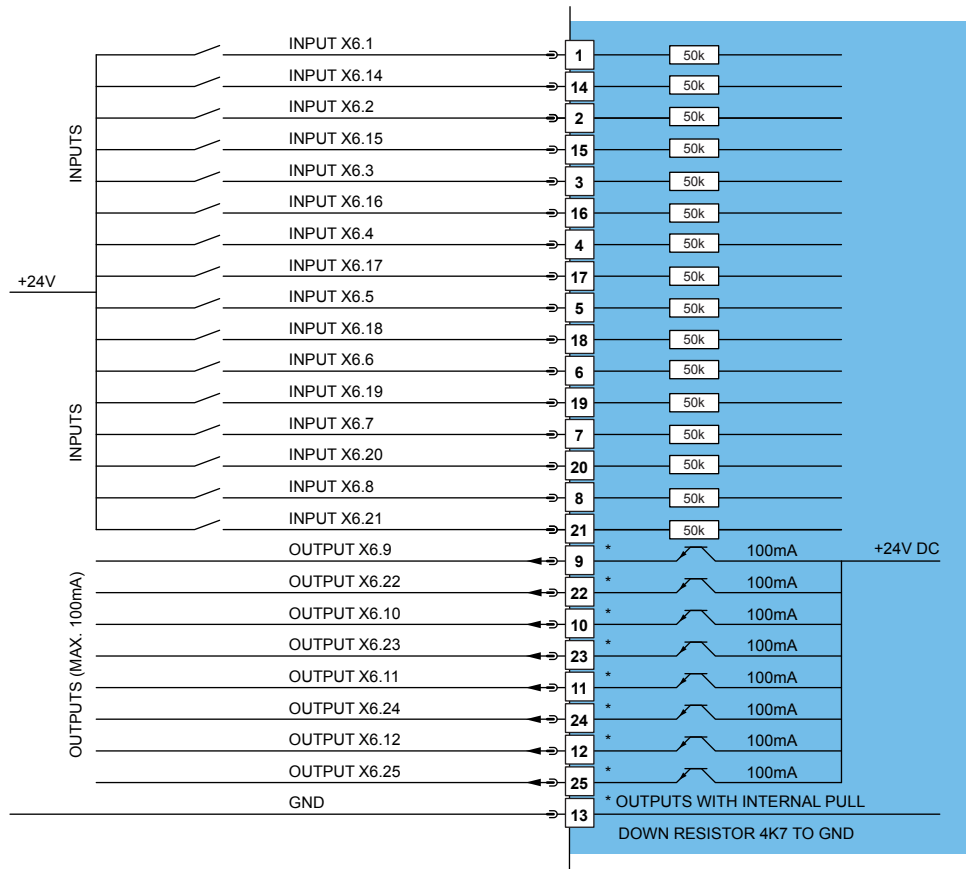

All Inputs: Direct interfacing to digital 24VDC PLC outputs.
 Input current: 1mA
 low level: -0.5...5VDC
 high level: 15...30VDC
 Sample rate: 625µs

All Outputs: Short circuit and overload protected high side switches
 Voltage: 24VDC
 Max. current: 100mA
 High Level: 15...30VDC
 Update rate: 625µs

Outputs may directly drive inductive loads

X5 COM

COM Interface

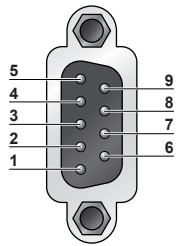

X5: DSUB-9 (m)

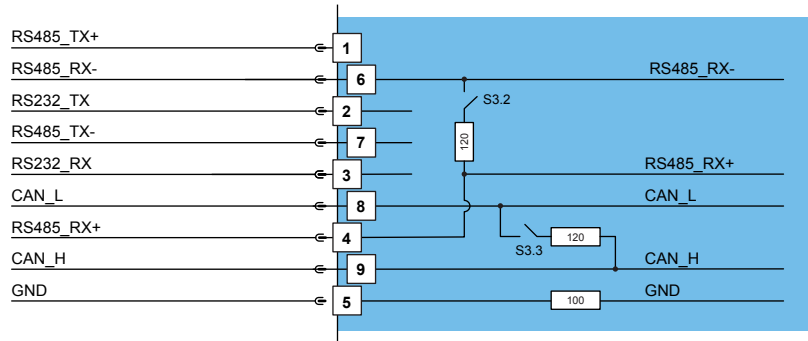

RS232: Configuration on all Drives: use 1:1 connection cable to PC

LED

State Display

Green:

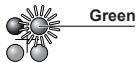

24VDC Logic Supply OK

Stat A Yellow:

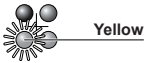

Motor Enabled

Stat B Yellow:



Warning

Red:



Error

X7-X8

RS485/CAN

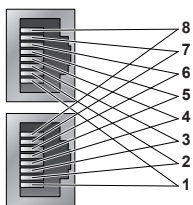

RJ-45

Nr		
1	RS485_Rx+	A
2	RS485_Rx-	B
3	RS485_Tx+	Y
4	GND	
5	GND	
6	RS485_Tx-	Z
7	CAN_H	
8	CAN_L	
Case	Shield	

- X7 internally connected to X8 (1:1 connection)
- Use twisted pair (1-2, 3-6, 4-5, 7-8) cable for wiring.
- The built in CAN and RS485 terminations can be activated by S3.2 and S3.3.

X9

Profibus DP

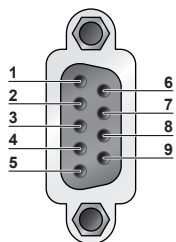

DSUB-9

Nr		
1	-	
2	-	
3	RxD/TxD-P	
4	CNTR-P	
5	GND	(galvanically seperated)
6	+5V	(galvanically seperated)
7	-	
8	RxD/TxD-N	
9	-	
Case	Shield	

Max. Baud rate: 12 Mbaud

X10-X11

Master Encoder IN (X10) / Master Encoder OUT (X11)

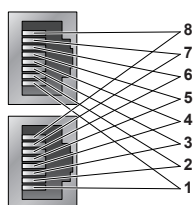

RJ-45

Nr	Incremental	Step/Direction	EIA/TIA 568A colors
1	A+	Step+	Green/White
2	A-	Step-	Green
3	B+	Direction+	Orange/White
4	Z+	Zero+	Blue
5	Z-	Zero-	Blue/White
6	B-	Direction-	Orange
7	CAN_H*	CAN_H*	Brown/White
8	CAN_L*	CAN_L*	Brown
Case	Shield	Shield	

*only on E1100-GP

- CAN internally connected to X7, X8
- CAN und RS485 Termination can be turned on by S3.2 alt. S3.3.
- X10 an X11: Use twisted pair (1-2, 3-6, 4-5, 7-8) cable for wiring.
- X10 Master Encoder Inputs: Differential RS422, max. Input Frequency 4.5MHz
- X11 Master Encoder Outputs: Amplified RS422 differential signals from Master Encoder IN (X10)

X12

External Positions Sensor

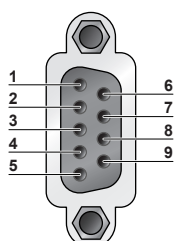

DSUB-9

Nr	Incremental:	Sin/Cos
1	+5V DDC	+5V DC
2	A-	SIN-
3	B-	COS-
4	Z-	ZERO-
5	GND	GND
6	A+	SIN+
7	B+	COS+
8	Z+	ZERO+
9	Enc. Alarm	Enc. Alarm
Case	Shield	Shield

Encoder Inputs: - Incremental: RS422
- Sin/Cos: 1Vpp

Maximal Input Frequency: 4.5 Mio. Incr./sec (incremental RS422), minimal pulsewidth > 220nsec
10kHz (analog 1Vpp), 10Bit AD

Sensor Supply: 5VDC (max. 100mA)

Sensor Alarm Input: 5V / 1mA

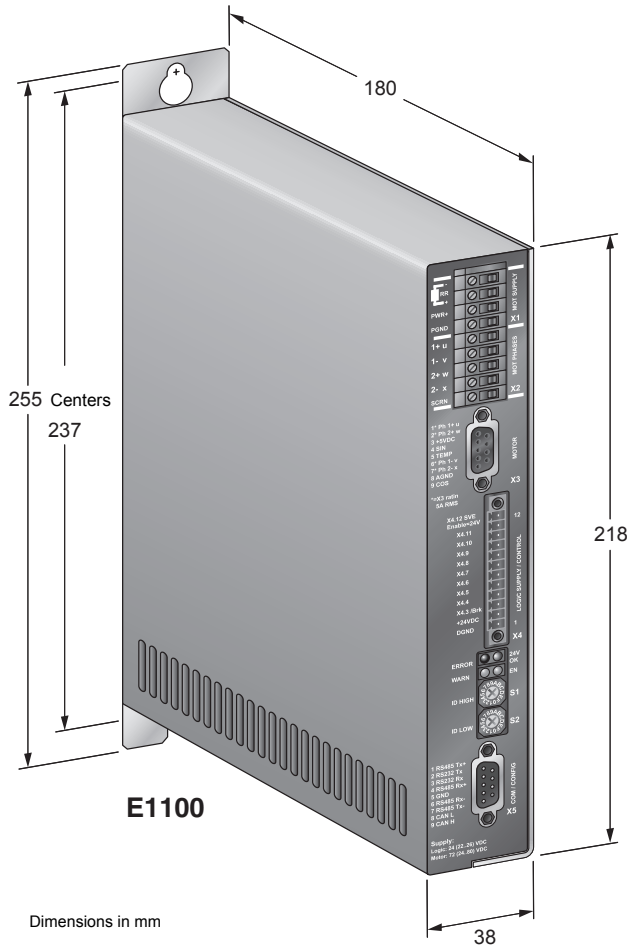

Servo Drives Series		E1100	
Width	mm (in)	38	(1.5)
Height	mm (in)	255	(10.0)
Height without fixings	mm (in)	218	(8.6)
Depth	mm (in)	180	(7.1)
Weight	kg (lb)	1.5	(3.3)
IP Protection class	IP	20	
Storage temperature	°C	-25...40	
Transport temperature	°C	-25...70	
Operating temperature	°C	0...40 at rated date	
		40...50 with power derating	
Max. case temperature	°C	65	
Max. power dissipation	W	30	
Min. distance between drives	mm (in)	20 (0.8)	left/right
		50 (2)	top/bottom

Artikel	Beschreibung	Artikelnummer
E1100-RS	RS232/485 Drive (72V/8A)	0150-1677
E1100-RS-HC	RS232/485 Drive (72V/15A)	0150-1678
E1100-RS-XC	RS232/485 Drive (72V/25A)	0150-1862
E1100-CO	CANopen Drive (72V/8A)	0150-1681
E1100-CO-HC	CANopen Drive (72V/15A)	0150-1682
E1100-CO-XC	CANopen Drive (72V/25A)	0150-1683
E1100-DN	DeviceNet Drive (72V/8A)	0150-1679
E1100-DN-HC	DeviceNet Drive (72V/15A)	0150-1680
E1100-DN-XC	DeviceNet Drive (72V/25A)	0150-1863
E1100-GP	General Purpose Drive (72V/8A)	0150-1665
E1100-GP-HC	General Purpose Drive (72V/15A)	0150-1666
E1100-GP-XC	General Purpose Drive (72V/25A)	0150-1864
E1130-DP	Profibus DP Drive, (72V/8A)	0150-1667
E1130-DP-HC	Profibus DP Drive, (72V/15A)	0150-1668
E1130-DP-XC	Profibus DP Drive, (72V/25A)	0150-1861

Switched-Mode Power Supplies

115VAC / 230VAC

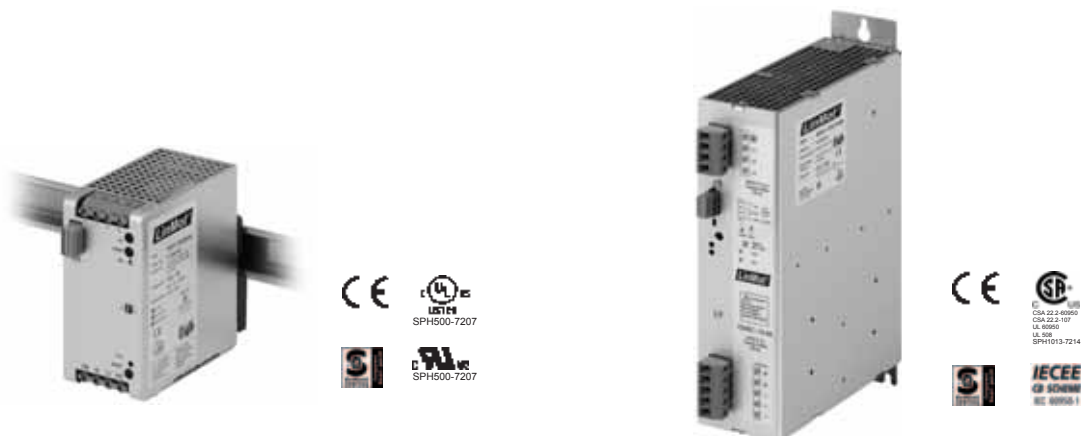

Item	Description	Part Number
S01-72/500	Switched-Mode Power Supply 72V/500W	0150-1874
S01-72/1000	Switched-Mode Power Supply 72V/1000W	0150-1872

Transformer Supply T01

3x230/280/400/480VAC



Item	Description	Part Number
T01-72/420...1500-Multi	Transformer Supply 3x230/280/400/480VAC, 50/60Hz, 420...1500W	see page 532

Control Box B01-E1100



Item	Description	Part Number
B01-E1100	Control Box for E1100 (incl. cable and connectors)	0150-1970

Connector Cable and USB-Converter



0150-3009

0150-3110

0150-3134

0150-2143

0150-1852

0150-1853

Item	Description	Part Number
RS232 PC config. cabel 2m	for E100/E1001	0150-3009
RS232 PC config. cabel 2m	for E100/E1001/E1100/B1100	0150-3307
RS232 PC config. cabel 2.5m	for E1200/E1400	0150-2143
USB-Serial Converter	USB to 9-pin Serial Converter	0150-3110
USB-CAN Converter	USB to CAN Converter for E1100	0150-3134
RJ45-08/0.3	RJ45 patch cable 0.3m for E1100	0150-1852
RJ45-08/0.6	RJ45 crossover patch cable 0.6m	0150-1853
RJ45/RJ45-0,2-ML1	MC-Link cable 0,2m	0150-3308

Option: External High Resolution Encoder



Item	Description	Part Number
MS01-1/D	Linear Encoder 1um, A/B (for 1mm magnetic band)	0150-1840
MB01-1000	Magnetic Band 1mm pitch, per cm	0150-1963

Servo Drive Series E1200



Servo Drive E1200

Series E1200 Servo Drives are modular axis drives, with 32-bit position resolution and an integrated power stage, for linear motors and rotary drives.

The drives are suitable for simplest, standard, and high-end positioning tasks, across the entire force range of the LinMot product range.



Connection to Machine Drive

The Series E1200 Servo Drives can be actuated by machine controls from any manufacturer or brand, via digital inputs and outputs, RS232 or RS485 serial interface, CanBus CANopen and DeviceNet interfaces, Profibus DP, or industrial ETHERNET.

Process and Safety Interfaces

Fast process interfaces for direct processing of sensor signals are available as freely programmable analog and digital inputs, a fast trigger input, and a capture input.

The safe pulse inhibitor on Servo Drive with fieldbus interfaces or industrial ETHERNET allows safe stop of the drives via control signals, per EN 954-1, without interrupting the power supply.

Logic and Power Supply

The Servo Drives have two separate power supply inputs for the logic and power elements.

In an E-stop and safe stop of the drive, only the power element supply is cut off from the drive. The logic supply and the drive continue to run.

This has the advantage that the drive and linear motor do not need to be reinitialized when the machine is restarted, since all process data, including the current position of the linear motor, are still up to date.

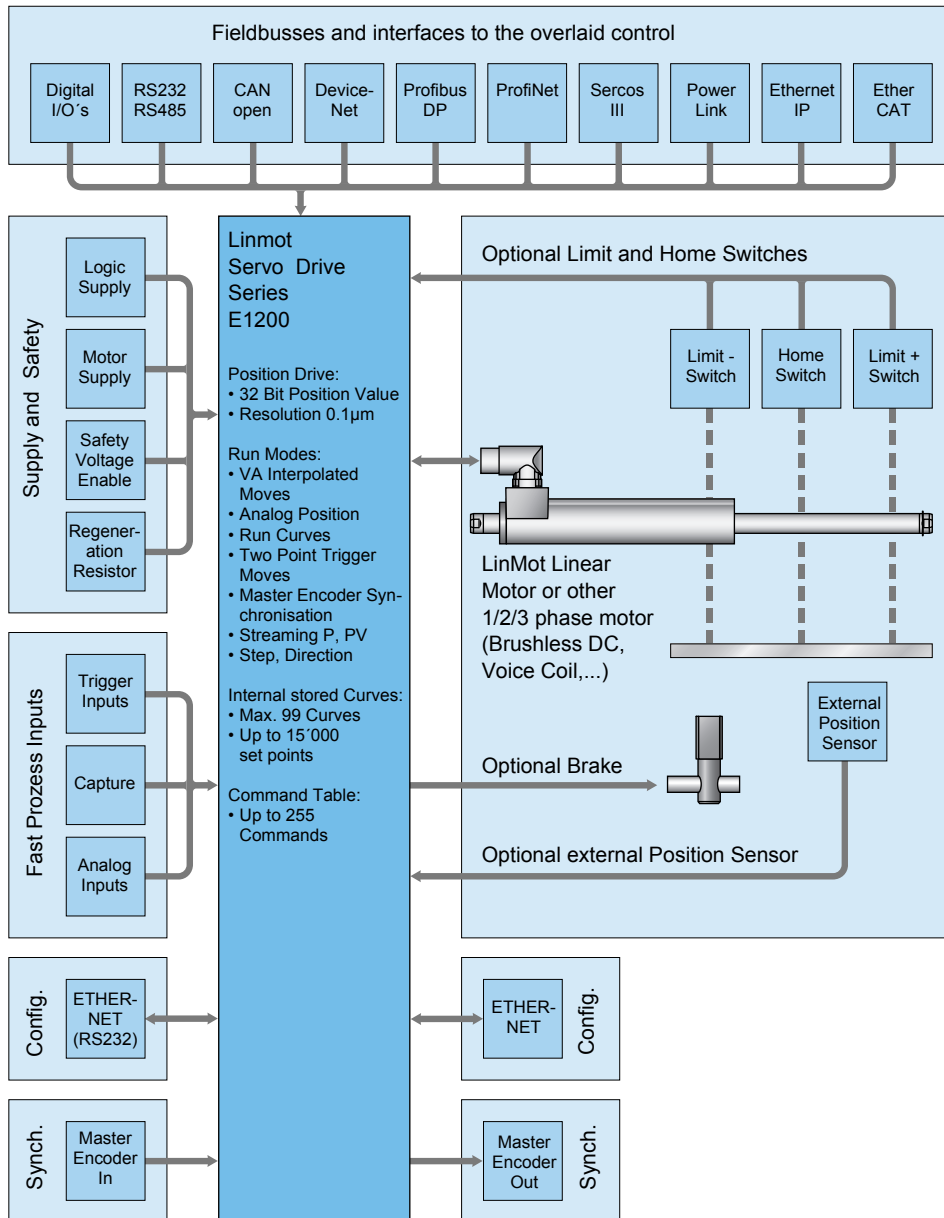

System Integration

Flexible hardware enables control of any 1/2/3-phase motors. Thus, low-power rotary servomotors, such as brushless DC motors, can be integrated in the same controls concept.

Additionally, the drives can be equipped with optional peripherals, such as reference and end stop switches, high-precision external position sensors, or a mechanical holding brake.

Series E1200 Servo Drives have analog and digital inputs and outputs, serial interfaces, fieldbuses, and ETHERNET connections. The user is therefore not dependent on the selection of the overlaid drive. An appropriate interface is available, with associated protocols, for any PLC or IPC solution.

With flexibility and a compact form factor, LinMot Series E1200 Servo Drives provide a complete solution for a flexible drive concept in single and multiple axis applications, with linear motors and other actuators.

Technology Functions

Technology functions are functional blocks that provide a complete solution for standard applications and frequently encountered, customer-specific problems. Technology functions can, for example, handle the complete sequence for winding textile yarns or glass fiber cables, or high-precision joining processes with force control can be implemented directly in the drive.

Option: Master Encoder Module

For synchronization to a mechanical master shaft, or a rotating main drive, the Axis (linear motors and rotary motors) can be coupled to an electronic main shaft via the Master Encoder Interface.

The encoder signal from the main shaft can be passed through by the Master Encoder Interface, so that any number of linear motors can be synchronized to the main shaft.

Motor Interfaces

E1200 Servo Drives provide all necessary interfaces to operate linear or rotary motors with optional external peripherals, such as end position and reference switches, a mechanical brake, or a high-resolution external position sensor.

In special applications, two drives can be synchronized with each other using the synchronization interface in master booster mode.

Configuration

Parameterization and configuration of the Servo Drive is done via the Ethernet interface on the front side for simultaneous configuration of several drives.

LinMot Talk user-friendly PC software is available for configuration. In addition to on-line documentation, LinMot Talk provides extensive debugging tools, such as an oscilloscope and an error inspector, for simple and rapid start-up of the Axis.

Fieldbus and ETHERNET drives can also be configured directly by the overlaid control.

Interpolated Moves

Stroke [mm]

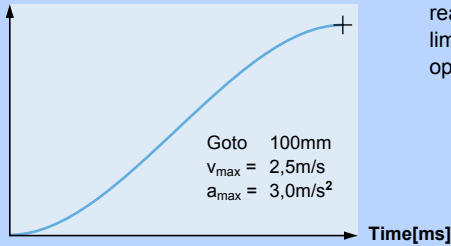

For direct position targets, using absolute or relative positioning, the desired position is reached using acceleration and velocity-limited motion profiles or jerk optimized profiles (jerk limited and Bestehorn). Positioning commands can be invoked via the serial interfaces, CAN-open, DeviceNet, Profibus, Ethernet or a trigger input

Stroke range:	±100m
Position Resolution:	0.1µm (32Bit)
Velocity Resolution:	1.0µm/s (32Bit)
Velocity Resolution:	10.0µm/s ² (32Bit)

Time Curves

Stroke [mm]

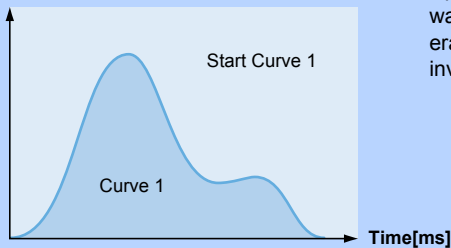

Up to 100 different time curves can be stored Series E1200 drives, with up to 16,000 individual waypoints. The motor can thus travel along time curves of any complexity, such as those generated by CAD programs and stored in the drive (Excel CSV format). The time curves can be invoked via the serial interface, fieldbuses, ETHERNET, or the trigger input.

Stroke range:	±100m
Position Resolution:	0.1µm (32Bit)
Motion profiles:	Max. 100 Time Curves
Curve points:	Max. 16'000 points

Profiled Moves

Stroke [mm]

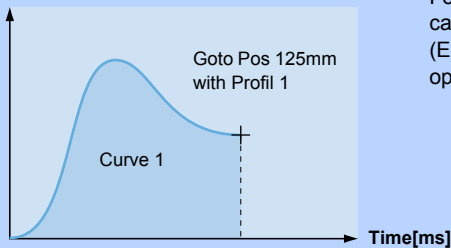

For travel to an absolute position, or shifting by a relative position, any desired motion rules can be stored besides the VA interpolator. They are stored in the drive as motion profiles (Excel CSV format). The positions can be approached, for example, with a sinusoidal motion to optimize power loss, or special reverse optimized motion profiles.

Stroke range:	±100m
Position Resolution:	0.1µm (32Bit)
Motion profiles:	Max. 100 Time Curves
Curve points:	Max. 16'000 points

Setpoint Streaming

Stroke [mm]

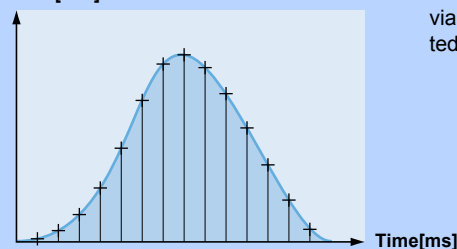

Overlaid NC drives with fieldbus or ETHERNET interfaces communicate with the Servo Drives via "Position Streaming". The position and velocity calculated in the overlaid control is transmitted to the Servo Drive cyclically. The P, PV, or PVT mode is available for this transmission.

Position Resolution:	32 Bit
Velocity Resolution:	32 Bit
Interpolator:	10 kHz
cycle times:	0.4-5ms

Easy Steps

Input 1	Pos 125mm
Input 2	Pos 250mm
Input 3	Curve 1
Input 4	Pos -30mm
Input 5	Pos +12,5mm
Input 6	Curve 2
Input 7	Pos 2mm
Input 8	Pos -12,5mm

With the Easy Steps function, up to 8 positions or independent travel commands can be stored on the drive, and addressed via 8 digital inputs or fieldbus interfaces/ETHERNET.

Digital inputs:	max. 8
Interface:	X4
Scanning rate:	200µsec

Command Table

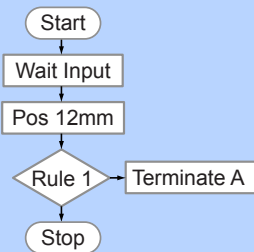

Entire motion sequences with up to 255 individual motion commands can be stored in the Command Table. This is primarily advantageous if complete motion sequences need to be executed very quickly, without dead time from the overlaid drive. In the Command Table, the programmer has access to all motion commands, internal parameters, and digital inputs and outputs.

Commands:	max. 255
Cycle time:	100µsec

Master Encoder Synchronization (MT)

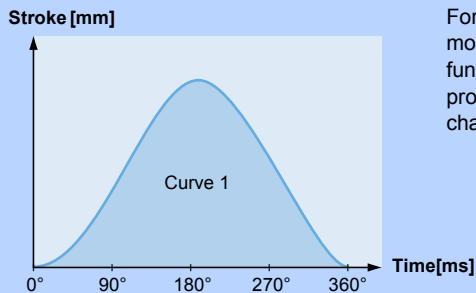

For synchronization to an external main or master shaft, the linear motor travels along the motion profiles stored in the drive, at the machine speed (machine angle 0...360°). Using this function, mechanical cam discs can be replaced with highly dynamic linear motors. The motion profiles can be freely defined, and the correct motion profile can be invoked during product changeover with no changeover time.

Motion profiles	Max. 100 curve profiles
Curve points:	Max. 16'000 points
Encoder Counter:	32 Bit
Encoder Input:	A/B/Z (RS422)
Max. counting frequency	Max. 4.5 MHz

Belt Synchronization

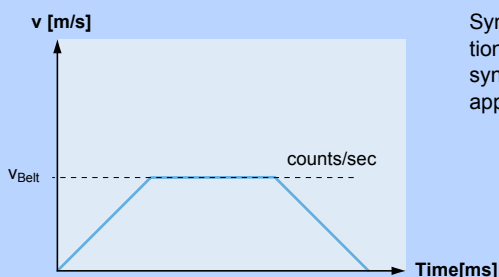

Synchronization to a belt speed can be done using the Master Encoder Interface or Step/Direction/Zero interface. Applications such as the "flying saw", synchronous loading or unloading, synchronous filling or labeling of bottles or containers on a conveyor belt, and many other applications can be implemented in this way.

Encoder Counter:	32 Bit
Encoder Input:	A/B/Z (RS422), max. 5 MHz
	STEP/DIR/ZERO
Max. counting frequency	Max. 4.5 MHz

Analog Position

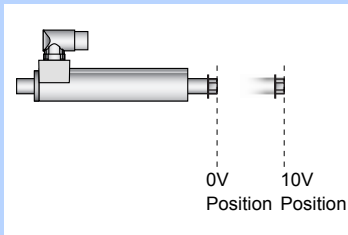

For an analog position target, the linear motor travels to a position proportional to the input voltage. The position is either scanned continuously, or only after a rising edge of the trigger signal. In order to prevent uncontrolled jumps in position, the motor travels to the positions with a programmable maximum acceleration and velocity (VA interpolator).

Inputs:	Analog Input X4 or X20
Voltage range:	0-10VDC or ±10V
Resolution:	12 Bit
Scanning rate:	>=100µsec (adjustable)

Easy Steps Parameter Scale

Maximum Force [0...10V => 0...100%]

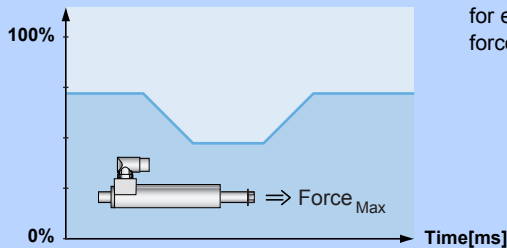

Easy Steps provide the ability to parameterize internal parameters using two analog inputs. If, for example, the maximum motor current is read at an analog input, then the maximum motor force can be provided as analog for freely programmable joining processes.

Inputs:	2 x Analog (X4.4, X4.7)
Voltage range:	0-10VDC
Resolution:	12 Bit
Resolution:	200µsec

Closed Loop Force Control

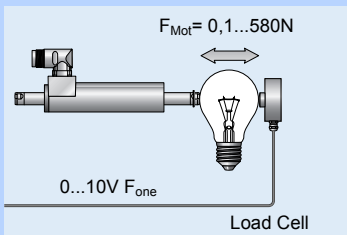

Using the force control technology function, precise joining processes can be implemented reliably and reproducibly with high-precision force control. For force control, the current motor force is measured with a load cell and controlled in the drive. Joining process or quality checks with high requirements for applied force can be implemented.

Analog Input:	0-10V or ±10V
Resolution:	12 Bit
Min. Force Resolution:	0.1N

Winding Application

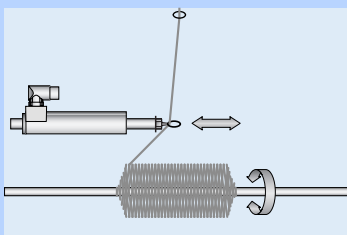

For winding textile yarns, glass fiber optics, or wires, a complete functional block is available that controls the entire sequence of a complete winding process.

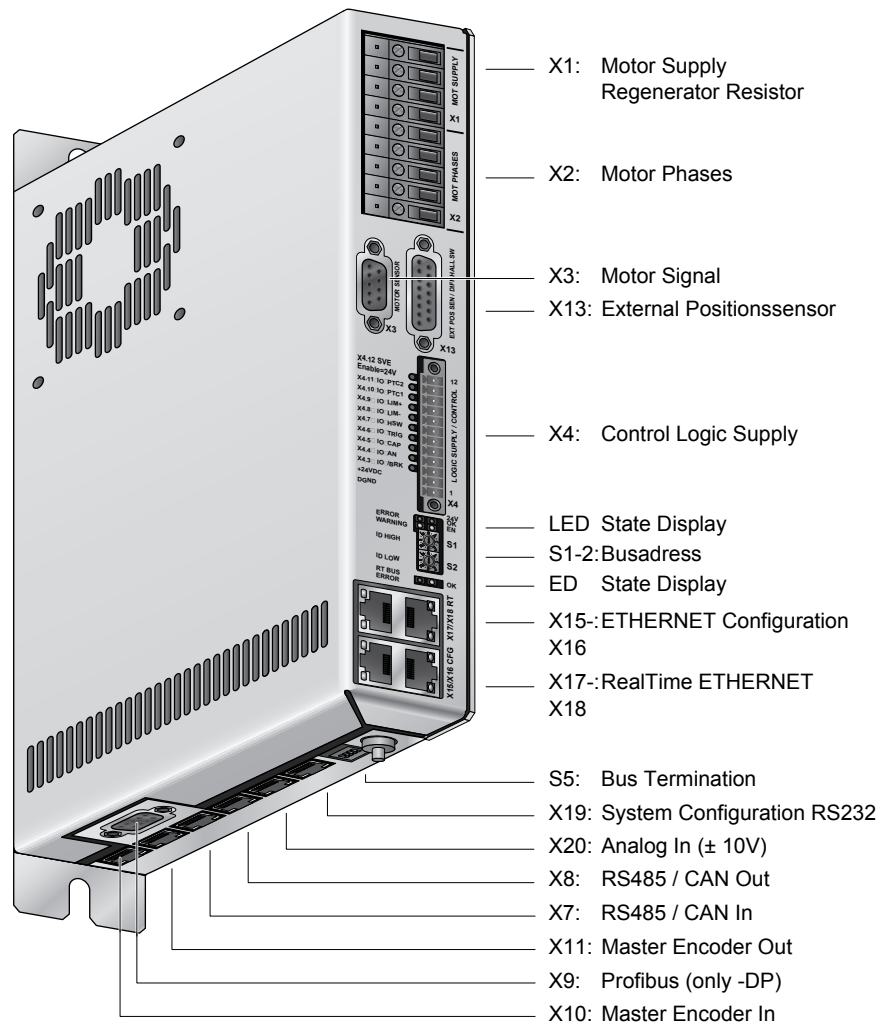

	E1200-GP-UC	E1230-DP-UC	E1250-PL-UC	E1250-EC-UC	E1250-PN-UC	E1250-IP-UC	E1250-SC-UC	E1250-SE-UC
Interfaces								
CANopen	•	•	•	•	•	•	•	•
DeviceNet	•	•	•	•	•	•	•	•
LinRS	•	•	•	•	•	•	•	•
PROFIBUS-DP		•						
POWERLINK			•					
ETHERCAT				•				•
PROFINET					•			
ETHERNET IP						•		
SERCOS III							•	
SERCOS over EtherCAT				•				•
Konfig ETHERNET	•	•	•	•	•	•	•	•

E1200-GP-UC
 E1230-DP-UC
 E1250-PL-UC
 E1250-EC-UC
 E1250-PN-UC
 E1250-IP-UC
 E1250-SC-UC

- ✓ Absolute & Relative Positioning
- ✓ Travel Along Time Curves
- ✓ Positioning using Motion Profiles
- ✓ Internally stored Motion Commands
- ✓ Internally stored Motion Sequences
- ✓ Master Encoder Synchronization
- ✓ Synchronization to Belt Speed
- ✓ Position Streaming
- ✓ Analog Position Target
- ✓ Analog Parameter Scaling
- ✓ Winding Function Block
- ✓ Force Control Technology Function
- ✓ Customer-Specific Functions

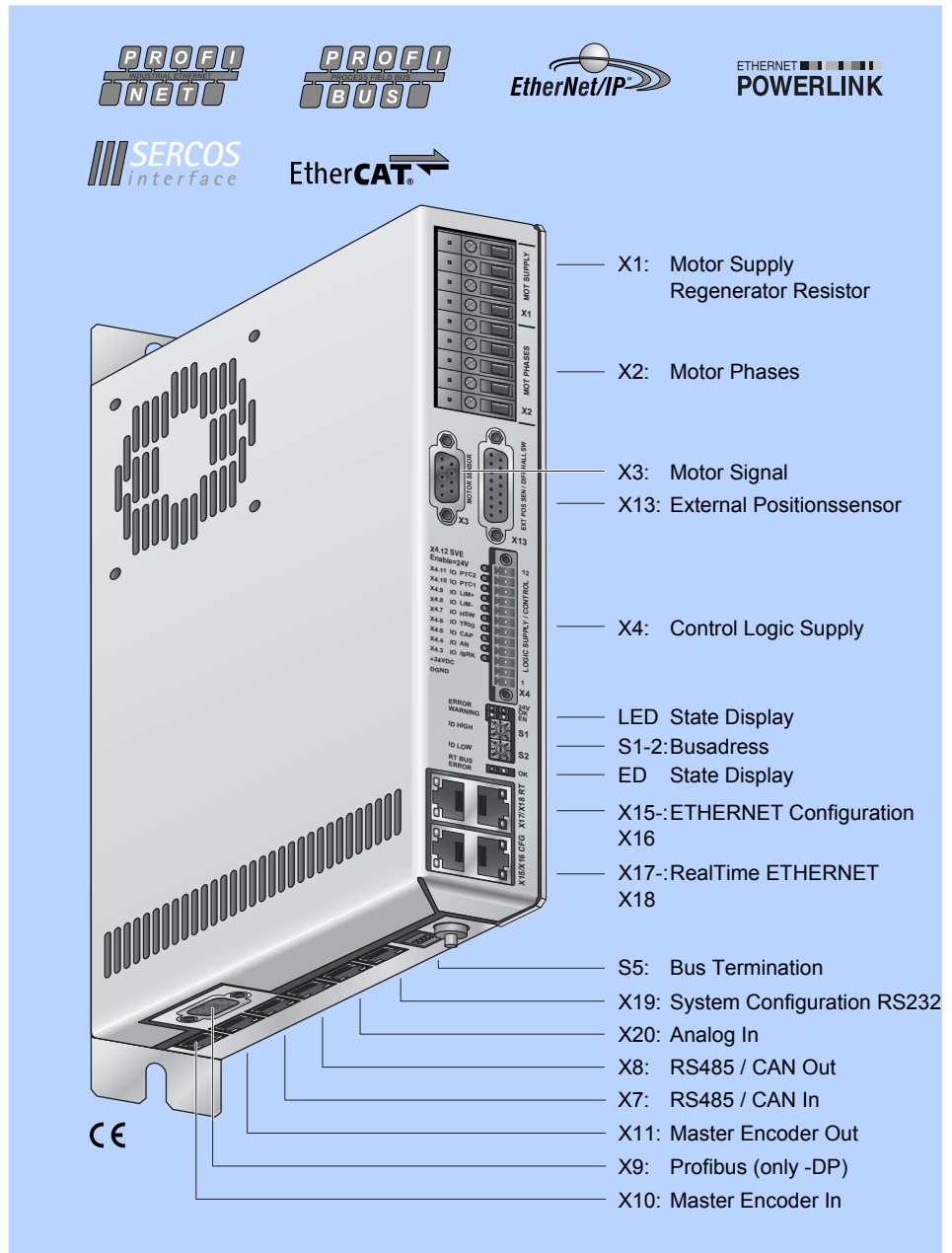

Industrial ETHERNET

Series E1200 drives allow integration of LinMot linear motors in controls concepts with industrial ETHERNET interfaces. The user can integrate Series E1200 drives regardless of the provider of the overlaid control.

LinMot drives are available with common industrial ETHERNET protocols. Since all ETHERNET drives have the same motion command interface, and the control and status word are identical, software blocks that have been implemented once can be transferred to other drives without a problem.

Series 1200 Servo Drives support the following industrial ETHERNET protocols:

- Profinet
- Industrial IP
- PowerLink
- EtherCat
- Sercos III

The appropriate drive is available for each protocol.

Technical Data

Type:	Realtime ETHERNET
Switch/Hub:	Integrated 2-Port Hub/Switch
Transfer rate:	10/100MBit/sec

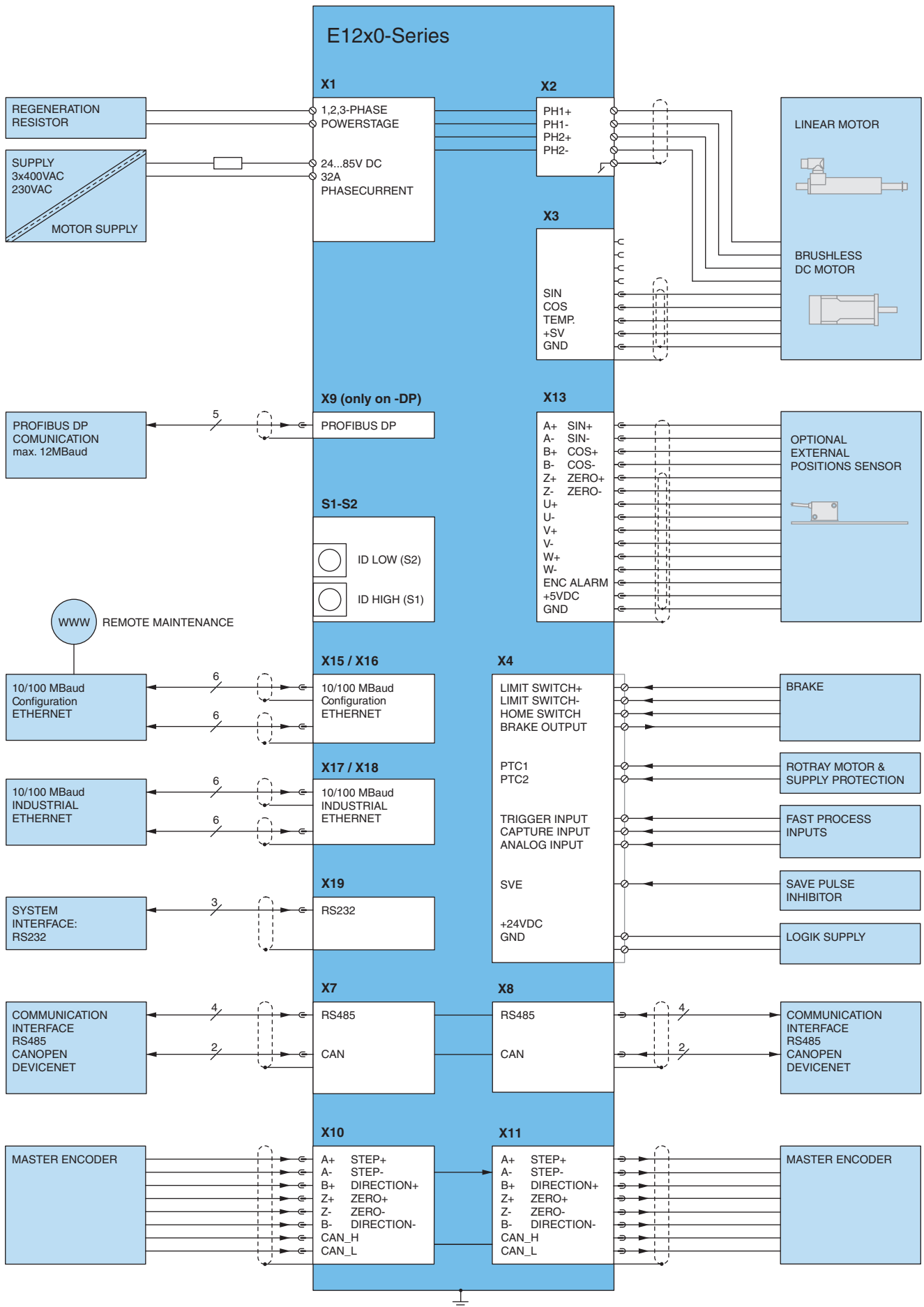

X1 Motor Supply / Regeneration Resistor

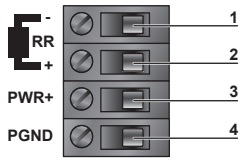

Screw Terminals
2.5 mm² (AWG14)

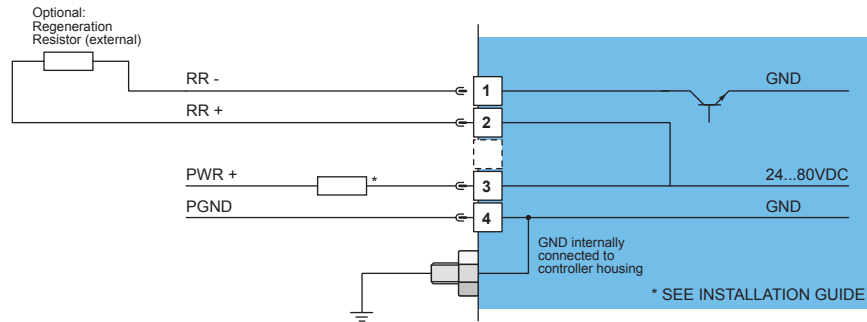

Motor Supply:

Motor Supply Voltage 24...85VDC.
Absolute max. Rating 72VDC + 20%



If motor supply voltage is exceeding 90VDC, the drive will go into error state

X2 Motor Phases

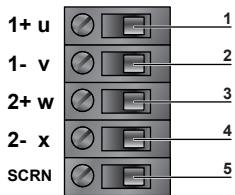

Screw Terminals
1.5-4mm²
(AWG16-14)

Nr.	Designation	LinMot Linear Motor	Color	3-Phase-Motor
1	PH1+ /U	Motor Phase 1+	red	Motor Phase U
2	PH1- /V	Motor Phase 1-	pink	Motor Phase V
3	PH2+ /W	Motor Phase 2+	blue	Motor Phase W
4	PH2-	Motor Phase 2-	grey	
5	SCRN	Shield		

X3 Motor

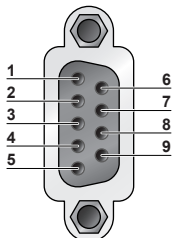

DSUB-9

Nr	LinMot Linear Motor	3-Phase-Motor
1	Motor Phase 1+	Motor Phase U
2	Motor Phase 2+	Motor Phase W
3	+5VDC	
4	Sine	Hall U
5	Temperature	Hall W
6	Motor Phase 1-	Motor Phase V
7	Motor Phase 2-	
8	AGND	
9	Cosine	Hall V
Case	Shield	

- Use X2 for motor phase wiring if phase current exceeds 5Arms or 7.5Apeak
- Use +5V (X3.3) and AGND (X3.8) only for motor internal Hall Sensor supply (max. 100mA)
- Do NOT connect AGND (X3.8) to ground or earth!

Motor

Motor wiring

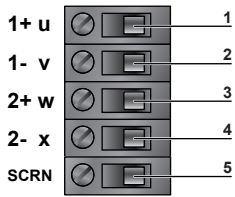

X2: Screw Terminals

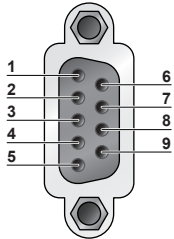

X3: DSUB-9 (f)

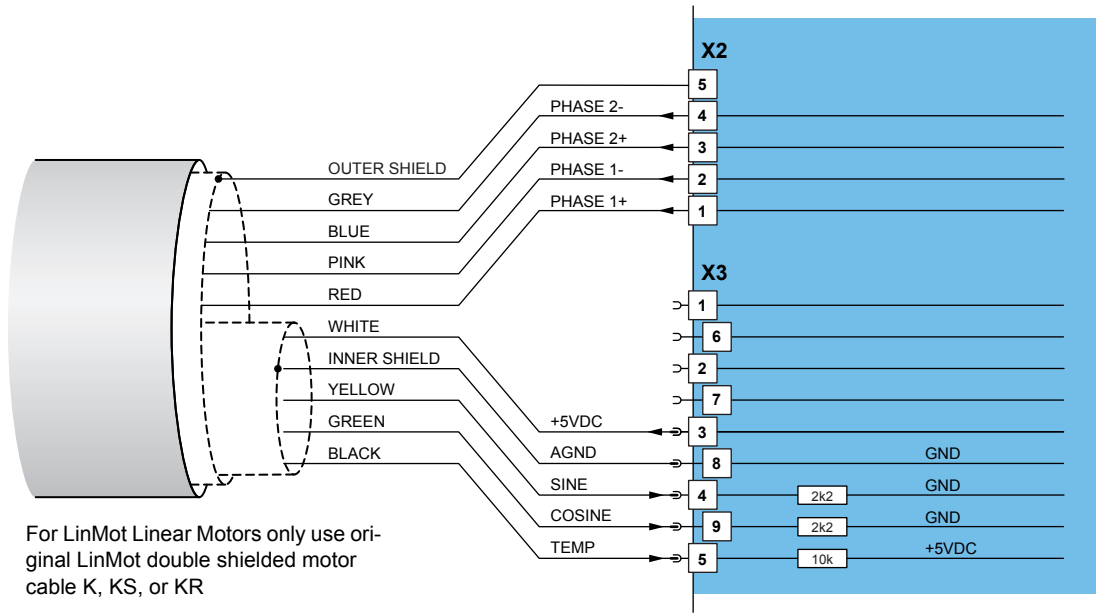

X4: 12pin

Control / Supply

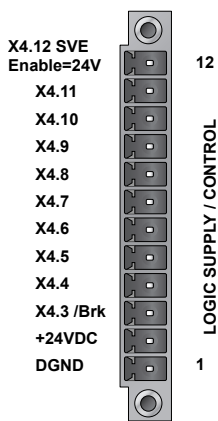

Phoenix MC1,5/12-STF-3,5
0.25-1.5mm² (AWG24-16)

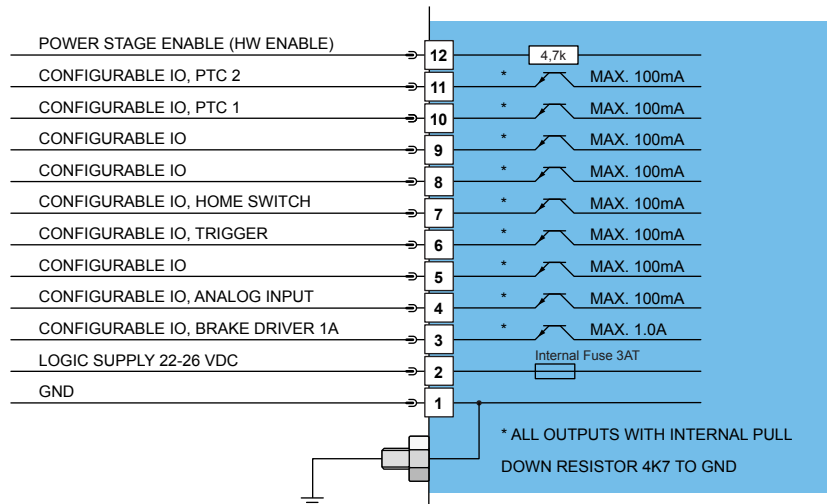

X7-X8

RS485/CAN

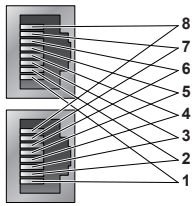

RJ-45

Nr		
1	RS485_Rx+	A
2	RS485_Rx-	B
3	RS485_Tx+	Y
4	GND	
5	GND	
6	RS485_Tx-	Z
7	CAN_H	
8	CAN_L	
Case	Shield	

- X7 internally connected to X8 (1:1 connection)
- Use twisted pair (1-2, 3-6, 4-5, 7-8) cable for wiring.
- The built in CAN and RS485 terminations can be activated by S5.

X9

Profibus DP

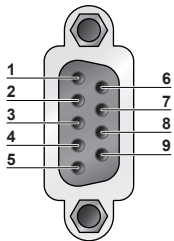

DSUB-9

Nr		
1	-	
2	-	
3	RxD/TxD-P	
4	CNTR-P	
5	GND	(galvanically seperated)
6	+5V	(galvanically seperated)
7	-	
8	RxD/TxD-N	
9	-	
Case	Shield	

Max. Baud rate: 12 Mbaud

X10-X11

Master Encoder IN (X10) / Master Encoder OUT (X11)

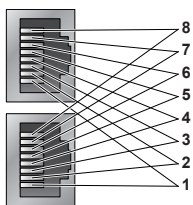

RJ-45

Nr	Incremental	Step/Direction	EIA/TIA 568A colors
1	A+	Step+	Green/White
2	A-	Step-	Green
3	B+	Direction+	Orange/White
4	Z+	Zero+	Blue
5	Z-	Zero-	Blue/White
6	B-	Direction-	Orange
7	CAN_H*	CAN_H*	Brown/White
8	CAN_L*	CAN_L*	Brown
Case	Shield	Shield	

*only on E1200-GP

- CAN Bus X10 and X11 in internally connected.
- CAN und RS485 Termination can be turned on by S5.
- X10 an X11: Use twisted pair (1-2, 3-6, 4-5, 7-8) cable for wiring.
- X10 Master Encoder Inputs: Differential RS422, max. Input Frequency 4.5MHz
- X11 Master Encoder Outputs: Amplified RS422 differential signals from Master Encoder IN (X10)

S1-3

Address Selectors / Bus Termination

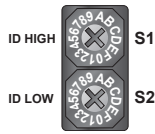

Switch		
S1	Bus ID High (0...F)	HEX-Switches for Bus ID address range 0.255
S2	Bus ID Low(0...F)	

S5

Bus Termination



Switch	E1200	
S5	Switch 1: AnIn2 Pulldown (4k7 Pulldown on X4.4). Set to ON, if X4.4 is used as digital Output.	
	Switch 2: Termination Resistor for RS485 on CMD (120R between pin 1 and 2 on X7/X8) on/off	
	Switch 3: CAN Termination on CMD (120R between pin 7 and 8 on X7/X8) on/off	
	Switch 4: CAN Termination on ME (120R between pin 7 and 8 on X10/X11) on/off	
	Factory settings: all switches "off"	

X13

External Position Sensor Commutation

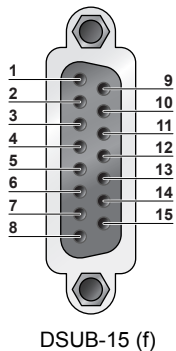

Nr	Description	
1	+5V DC	
9	A+	Encoder
2	A-	Encoder
10	B+	Encoder
3	B-	Encoder
11	Z+	Encoder
4	Z-	Encoder
12	Encoder Alarm	
5	GND	
13	U+	Commutation (Hall Switch)
6	U-	Commutation (Hall Switch)
14	V+	Commutation (Hall Switch)
7	V-	Commutation (Hall Switch)
15	W+	Commutation (Hall Switch)
8	W-	Commutation (Hall Switch)
case	Shield	

Max. Input Frequency: 12MHz (incremental RS422), 40ns edge separation

Sensor Supply Current: max. 100mA

Position Encoder Inputs: RS422, Max Input Frequency: 2,5MHz, 5 M counts/s with quadrature decoding, 40ns edge separation

Encoder Simulated Outputs:RS422, Max Output Frequency: 2.5MHz, 5 M counts/s with quadrature decoding, 40ns edge separation

Differential Hall Switch Inputs: RS422, Max Input Frequency: <1kHz

Enc. Alarm In: 5V / 1mA

Sensor Supply: 5VDC, max 100mA

X15-X16 Ethernet Configuration 10/100Mbit/s



RJ-45

Nr	Bez.
X15	Internal 2-Port 10BASE-T and 100BASE-TX Ethernet Switch
X16	HP Auto MDIX

X17-X18 Ethernet RealTime



RJ-45

Nr	Bez.
X17	Specification depends on RT-Bus Type. Please refer to according documentation.
X18	

X19 RS232 Configuration

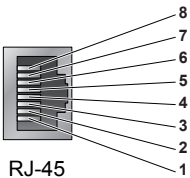

RJ-45

Nr	Bez.
1	Reserved, do not connect
2	Reserved, do not connect
3	RS232 RX
4	GND
5	GND
6	RS232 TX
7	Reserved, do not connect
8	Reserved, do not connect
case	Shield

X20 Analog In (+10V Differential Analog Input)

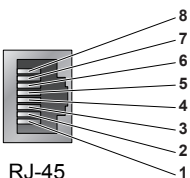

RJ-45

Nr	Bez.
1	n.c.
2	n.c.
3	Analog In-
4	GND
5	GND
6	Analog In+
7	n.c.
8	n.c.
case	Shield

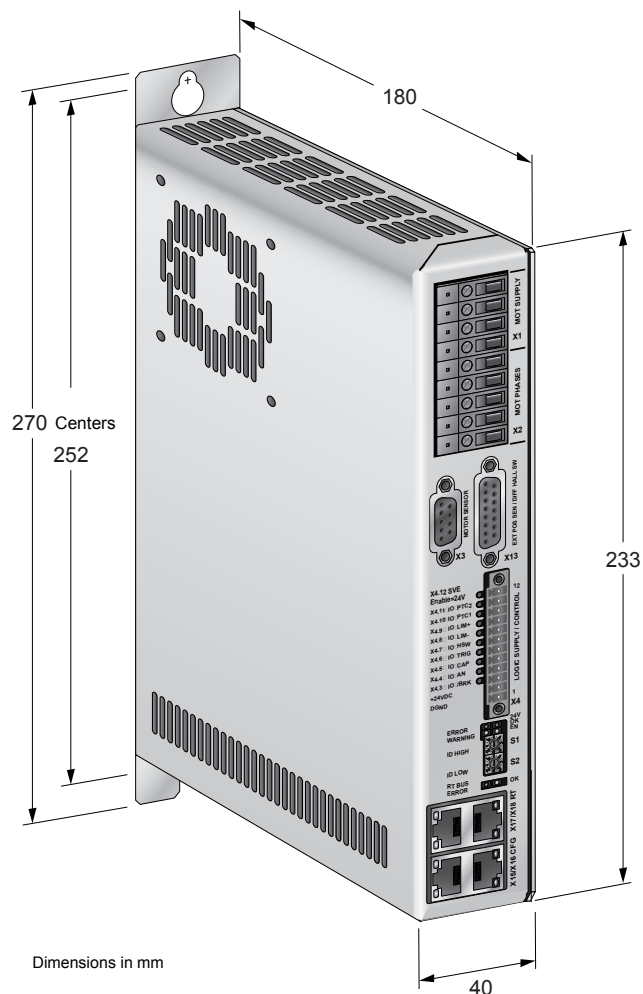

Servo Drives Series		E1200	
Width	mm (in)	40	(1.6)
Height	mm (in)	270	(10.6)
Height without fixings	mm (in)	233	(9.2)
Depth	mm (in)	180	(7.1)
Weight	kg (lb)	1.5	(3.3)
IP Protection class	IP	20	
Storage temperature	°C	-25...40	
Transport temperature	°C	-25...70	
Operating temperature	°C	0...40 at rated date 40...50 with power derating	
Max. case temperature	°C	65	
Max. power dissipation	W	30	
Min. distance between drives	mm (in)	20 (0.8)	left/right
		50 (2)	top/bottom

Item	Description	Part Number
E1200-GP-UC	General Purpose Drive (72V/32A)	0150-1771
E1230-DP-UC	Profibus DP Drive (72V/32A)	0150-1766
E1250-EC-UC	EtherCAT Drive (72V/32A)	0150-1763
E1250-PL-UC	PowerLink Drive (72V/32A)	0150-1760
E1250-IP-UC	Ethernet IP Drive (72V/32A)	0150-1761
E1250-PN-UC	Profinet Drive (72V/32A)	0150-1762
E1250-SC-UC	Sercos III Drive (72V/32A)	0150-1764
E1250-SE-UC	Sercos over EtherCAT Drive (72V/32A)	0150-1898

Servo Drive Series C1200



Servo Drive C1200

Series C1200 Servo Drives are modular axis controllers, with 32-bit position resolution and an integrated power stage, for linear motors and rotary drives.

The controllers are suitable for simplest, standard, and high-end positioning tasks, across the entire force range of the LinMot product range.



Connection to Machine Drive

The Series C1200 Servo Drives can be actuated by machine controls from any manufacturer or brand, via digital inputs and outputs, RS232 or RS485 serial interface, CanBus CANopen and DeviceNet interfaces, Profibus DP, or industrial ETHERNET.

Process and Safety Interfaces

Fast process interfaces for direct processing of sensor signals are available as freely programmable analog and digital inputs, a fast trigger input, and a capture input.

Logic and Power Supply

The Servo Drives have two separate power supply inputs for the logic and power elements.

In an E-stop and safe stop of the drive, only the power element supply is cut off from the drive. The logic supply and the drive continue to run.

This has the advantage that the drive and linear motor do not need to be reinitialized when the machine is restarted, since all process data, including the current position of the linear motor, are still up to date.

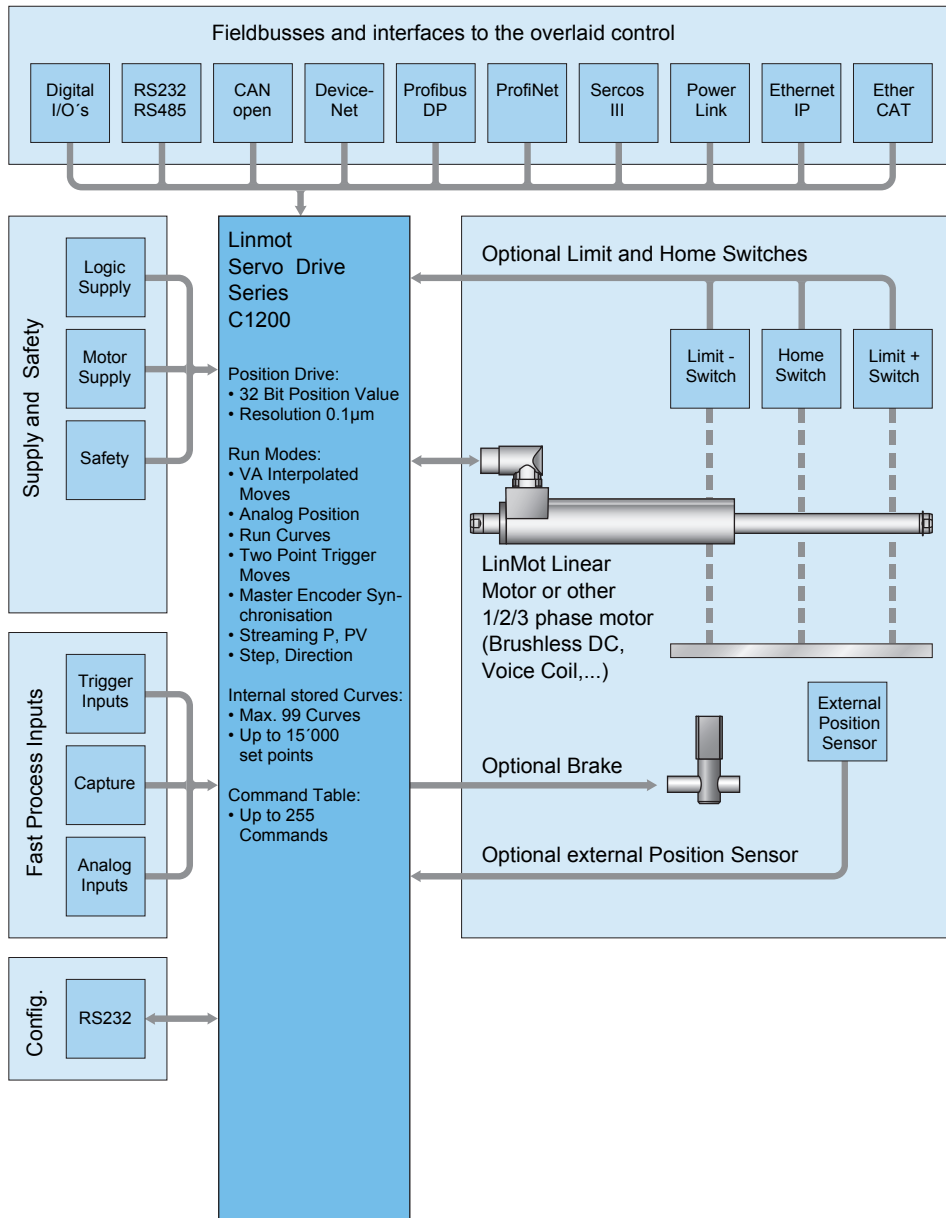

System Integration

Flexible hardware enables control of any 1/2/3-phase motors. Thus, low-power rotary servomotors, such as brushless DC motors, can be integrated in the same controls concept.

Additionally, the drives can be equipped with optional peripherals, such as reference and end stop switches, high-precision external position sensors, or a mechanical holding brake.

Series C1200 Servo Drives have analog and digital inputs and outputs, serial interfaces, fieldbuses, and ETHERNET connections. The user is therefore not dependent on the selection of the overlaid controller. An appropriate interface is available, with associated protocols, for any PLC or IPC solution.

With flexibility and a compact form factor, LinMot Series C1200 Servo Drives provide a complete solution for a flexible drive concept in single and multiple axis applications, with linear motors and other actuators.

Technology Functions

Technology functions are functional blocks that provide a complete solution for standard applications and frequently encountered, customer-specific problems. Technology functions can, for example, handle the complete sequence for winding textile yarns or glass fiber cables, or high-precision joining processes with force control can be implemented directly in the drive.

Motor Interfaces

C1200 Servo Drives provide all necessary interfaces to operate linear or rotary motors with optional external peripherals, such as end position and reference switches, a mechanical brake, or a high-resolution external position sensor.

In special applications, two drives can be synchronized with each other using the synchronization interface in master booster mode.

Configuration

LinMot Talk user-friendly PC software is available for configuration. In addition to on-line documentation, LinMot Talk provides extensive debugging tools, such as an oscilloscope and an error inspector, for simple and rapid start-up of the Axis.

Fieldbus and ETHERNET drives can also be configured directly by the overlaid control.

Interpolated Moves

Stroke [mm]

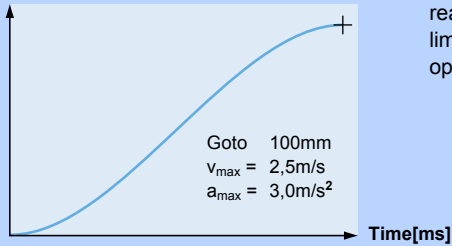

For direct position targets, using absolute or relative positioning, the desired position is reached using acceleration and velocity-limited motion profiles or jerk optimized profiles (jerk limited and Bestehorn). Positioning commands can be invoked via the serial interfaces, CAN-open, DeviceNet, Profibus, Ethernet or a trigger input.

Stroke range:	±100m
Position Resolution:	0.1µm (32Bit)
Velocity Resolution:	1.0µm/s (32Bit)
Velocity Resolution:	10.0µm/s ² (32Bit)

Time Curves

Stroke [mm]

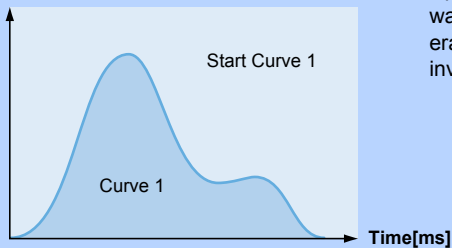

Up to 100 different time curves can be stored Series C1200 drives, with up to 16,000 individual waypoints. The motor can thus travel along time curves of any complexity, such as those generated by CAD programs and stored in the drive (Excel CSV format). The time curves can be invoked via the serial interface, fieldbuses, ETHERNET, or the trigger input.

Stroke range:	±100m
Position Resolution:	0.1µm (32Bit)
Motion profiles:	Max. 100 Time Curves
Curve points:	Max. 16'000 points

Profiled Moves

Stroke [mm]

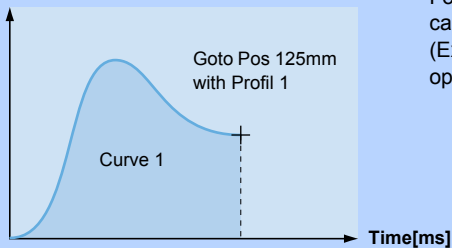

For travel to an absolute position, or shifting by a relative position, any desired motion rules can be stored besides the VA interpolator. They are stored in the drive as motion profiles (Excel CSV format). The positions can be approached, for example, with a sinusoidal motion to optimize power loss, or special reverse optimized motion profiles.

Stroke range:	±100m
Position Resolution:	0.1µm (32Bit)
Motion profiles:	Max. 100 Time Curves
Curve points:	Max. 16'000 points

Setpoint Streaming

Stroke [mm]

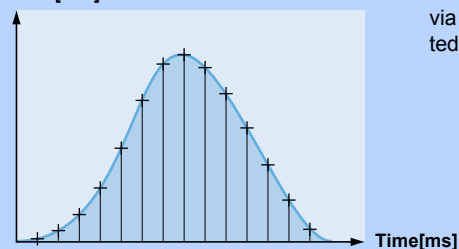

Overlaid NC drives with fieldbus or ETHERNET interfaces communicate with the Servo Drives via "Position Streaming". The position and velocity calculated in the overlaid control is transmitted to the Servo Drive cyclically. The P, PV, or PVT mode is available for this transmission.

Position Resolution:	32 Bit
Velocity Resolution:	32 Bit
Interpolator:	10 kHz
cycle times:	0.4-5ms

Easy Steps

Input 1	Pos 125mm
Input 2	Pos 250mm
Input 3	Curve 1
Input 4	Pos -30mm
Input 5	Pos +12,5mm
Input 6	Curve 2
Input 7	Pos 2mm
Input 8	Pos -12,5mm

With the Easy Steps function, up to 8 positions or independent travel commands can be stored on the drive, and addressed via 8 digital inputs or fieldbus interfaces/ETHERNET.

Digital inputs:	max. 8
Interface:	X4
Scanning rate:	200µsec

Command Table

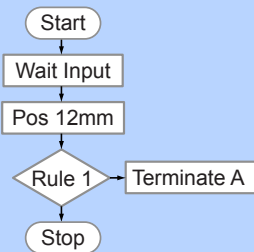

Entire motion sequences with up to 255 individual motion commands can be stored in the Command Table. This is primarily advantageous if complete motion sequences need to be executed very quickly, without dead time from the overlaid drive. In the Command Table, the programmer has access to all motion commands, internal parameters, and digital inputs and outputs.

Commands:	max. 255
Cycle time:	100µsec

Analog Position

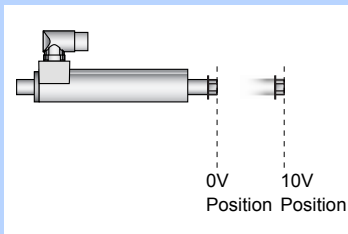

For an analog position target, the linear motor travels to a position proportional to the input voltage. The position is either scanned continuously, or only after a rising edge of the trigger signal. In order to prevent uncontrolled jumps in position, the motor travels to the positions with a programmable maximum acceleration and velocity (VA interpolator).

Inputs:	Analog Input X4 or X20
Voltage range:	0-10VDC or ±10V
Resolution:	12 Bit
Scanning rate:	>=100µsec (adjustable)

Easy Steps Parameter Scale

Maximum Force [0...10V => 0...100%]

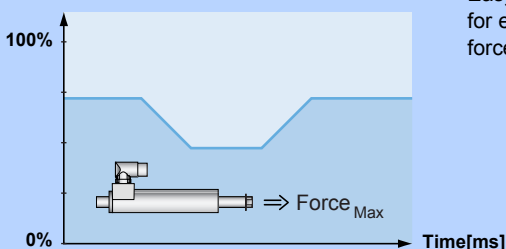

Easy Steps provide the ability to parameterize internal parameters using two analog inputs. If, for example, the maximum motor current is read at an analog input, then the maximum motor force can be provided as analog for freely programmable joining processes.

Inputs:	2 x Analog (X4.4, X4.7)
Voltage range:	0-10VDC
Resolution:	12 Bit
Resolution:	200µsec

Closed Loop Force Control

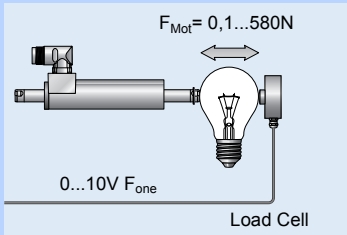

Using the force control technology function, precise joining processes can be implemented reliably and reproducibly with high-precision force control. For force control, the current motor force is measured with a load cell and controlled in the drive. Joining process or quality checks with high requirements for applied force can be implemented.

Analog Input:	0-10V or $\pm 10V$
Resolution:	12 Bit
Min. Force Resolution:	0.1N

Winding Application

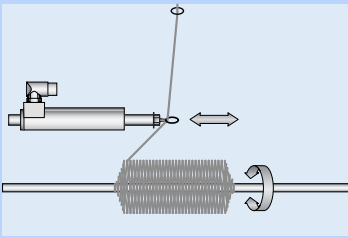

For winding textile yarns, glass fiber optics, or wires, a complete functional block is available that controls the entire sequence of a complete winding process.

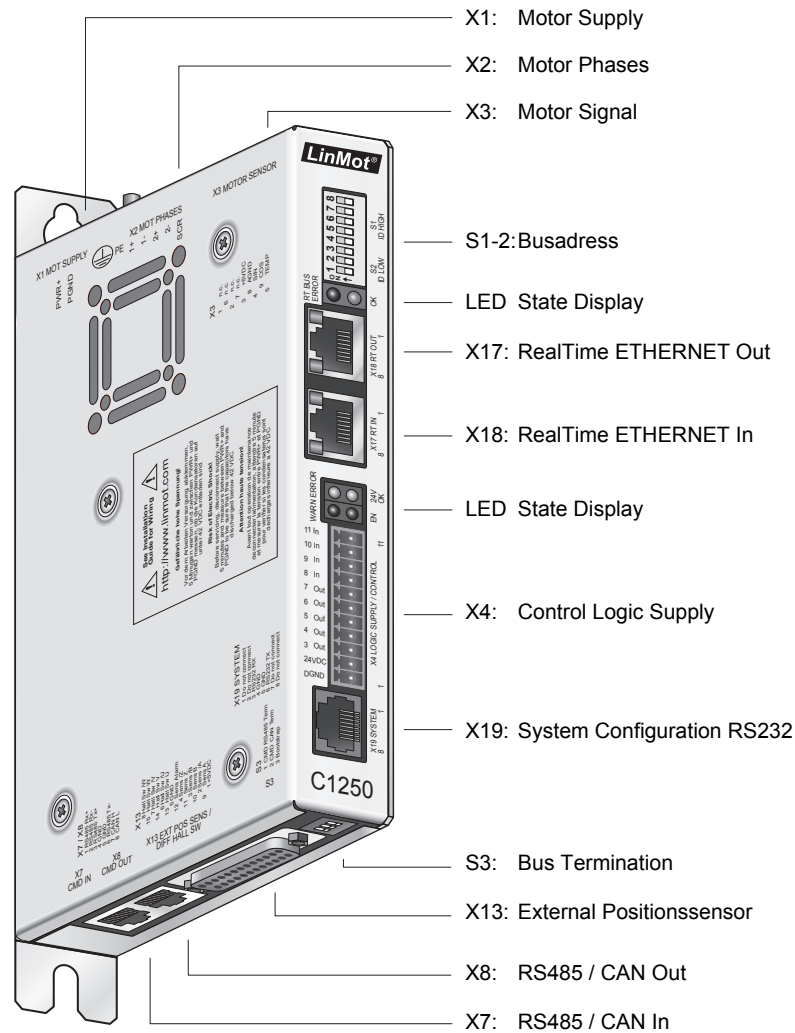

	C1200-GP-XC	C1230-DP-XC	C1250-PL-XC	C1250-EC-XC	C1250-PN-XC	C1250-IP-XC	C1250-SC-XC	C1250-SE-XC
Interfaces								
CANopen	•	•	•	•	•	•	•	•
DeviceNet	•	•	•	•	•	•	•	•
LinRS	•	•	•	•	•	•	•	•
PROFIBUS-DP		•						
POWERLINK			•					
ETHERCAT				•				•
PROFINET					•			
ETHERNET IP						•		
SERCOS III							•	
SERCOS over EtherCAT				•				•
Konfig RS232	•	•	•	•	•	•	•	•

C1200-GP-XC
 C1230-DP-XC
 C1250-PL-XC
 C1250-EC-XC
 C1250-PN-XC
 C1250-IP-XC
 C1250-SC-XC

- ✓ Absolute & Relative Positioning
- ✓ Travel Along Time Curves
- ✓ Positioning using Motion Profiles
- ✓ Internally stored Motion Commands
- ✓ Internally stored Motion Sequences
- ✓ Position Streaming
- ✓ Analog Position Target
- ✓ Analog Parameter Scaling
- ✓ Force Control Technology Function
- ✓ Customer-Specific Functions

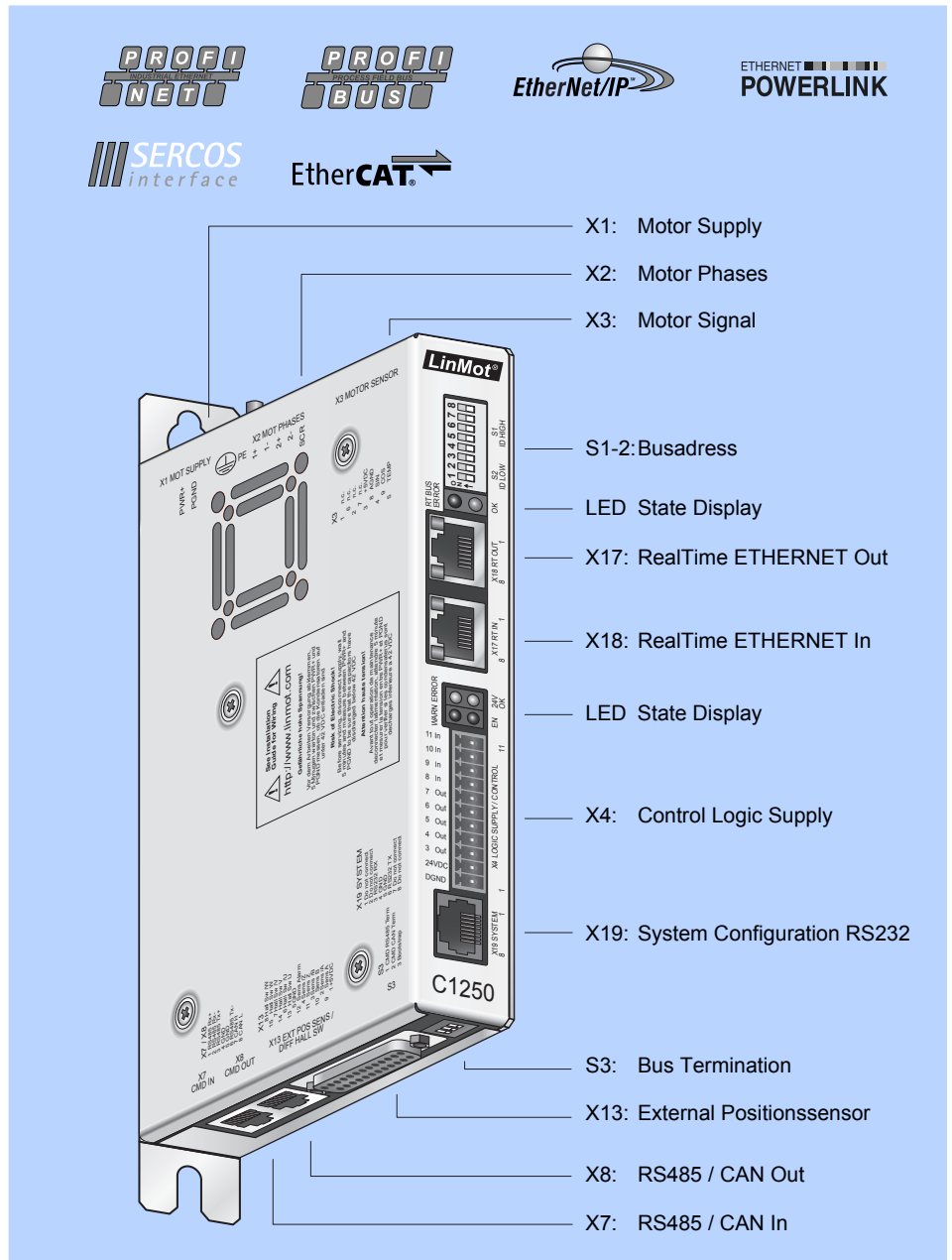

Industrial ETHERNET

Series C1200 drives allow integration of LinMot linear motors in controls concepts with industrial ETHERNET interfaces. The user can integrate Series C1200 drives regardless of the provider of the overlaid control.

LinMot drives are available with common industrial ETHERNET protocols. Since all ETHERNET drives have the same motion command interface, and the control and status word are identical, software blocks that have been implemented once can be transferred to other drives without a problem.

Technical Data

Series 1200 Servo Drives support the following industrial ETHERNET protocols:

- Profinet
- Industrial IP
- PowerLink
- EtherCat
- Sercos III

The appropriate drive is available for each protocol.

Technical Data

Type:	Realtime ETHERNET
Switch/Hub:	Integrated 2-Port Hub/Switch
Transfer rate:	10/100MBit/sec

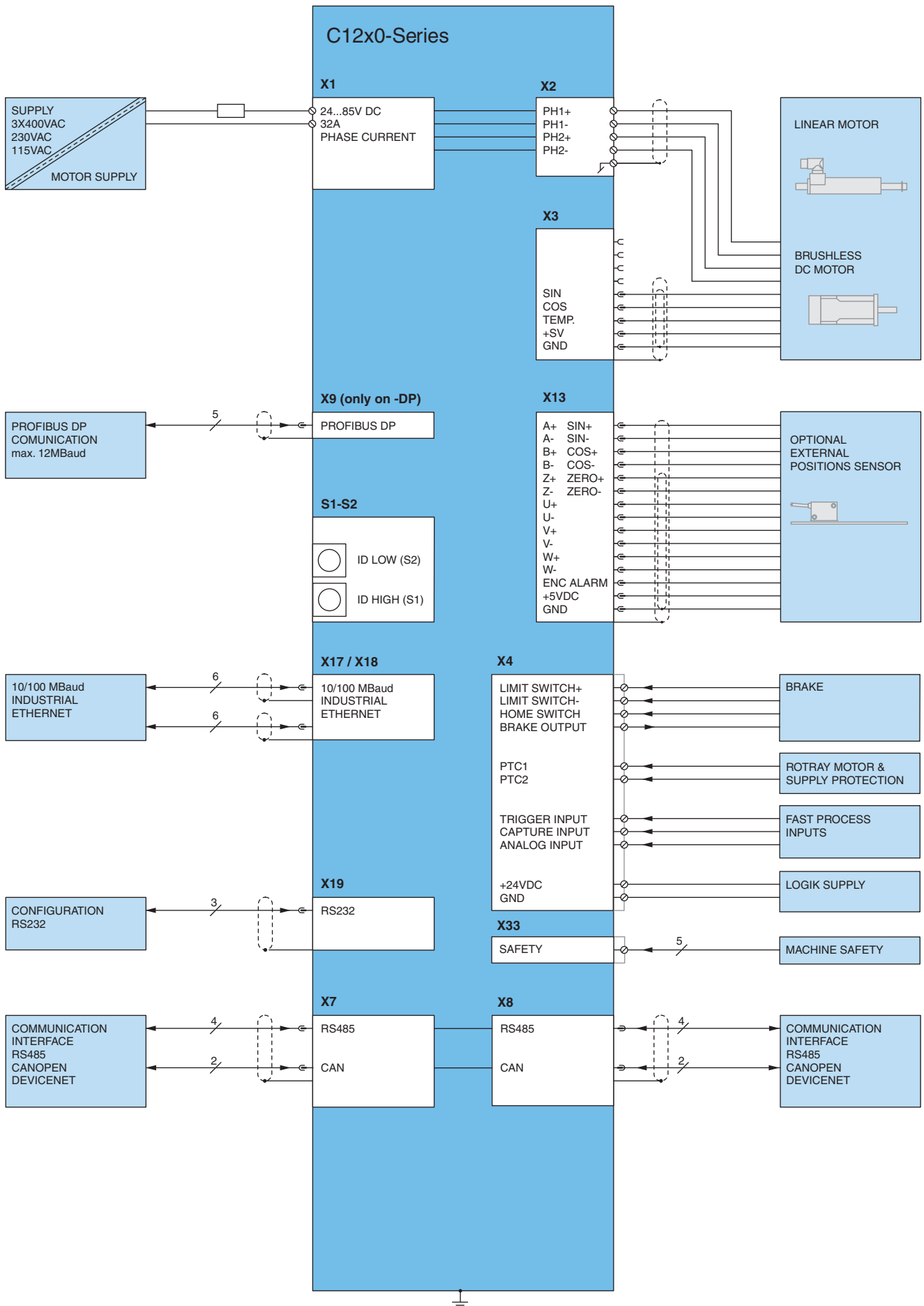

X1 Motor Supply / Regeneration Resistor



Screw Terminals
2.5 mm² (AWG14)

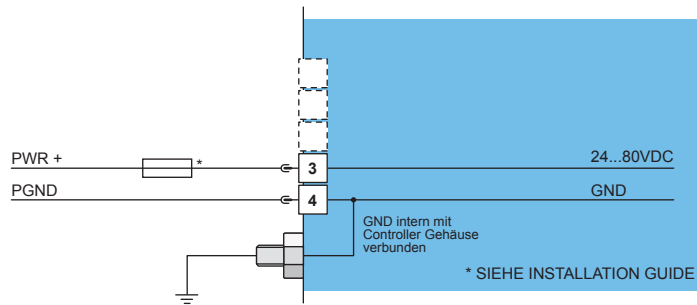

Motor Supply:

Motor Supply Voltage 24...85VDC.
Absolute max. Rating 72VDC + 20%



If motor supply voltage is exceeding 90VDC, the controller will go into error state

X2 Motor Phases

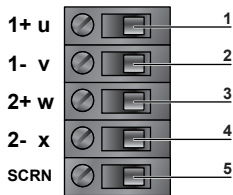

Screw Terminals
1.5-4mm²
(AWG16-14)

Nr.	Designation	LinMot Linear Motor	Color	3-Phase-Motor
1	PH1+ /U	Motor Phase 1+	red	Motor Phase U
2	PH1- /V	Motor Phase 1-	pink	Motor Phase V
3	PH2+ /W	Motor Phase 2+	blue	Motor Phase W
4	PH2- /	Motor Phase 2-	grey	
5	SCRN	Shield		

X3 Motor

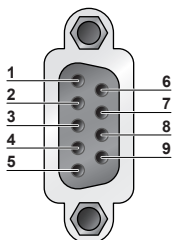

DSUB-9

Nr	LinMot Linear Motor
1	Motor Phase 1+
2	Motor Phase 2+
3	+5VDC
4	Sine
5	Temperature
6	Motor Phase 1-
7	Motor Phase 2-
8	AGND
9	Cosine
Case	Shield

- Use X2 for motor phase wiring if phase current exceeds 5Arms or 7.5Apeak
- Use +5V (X3.3) and AGND (X3.8) only for motor internal Hall Sensor supply (max. 100mA)
- Do NOT connect AGND (X3.8) to ground or earth!

Motor

Motor wiring

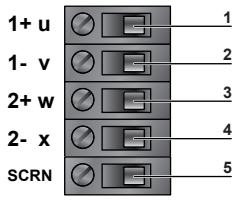

X2: Screw Terminals

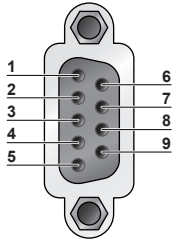

X3: DSUB-9 (f)

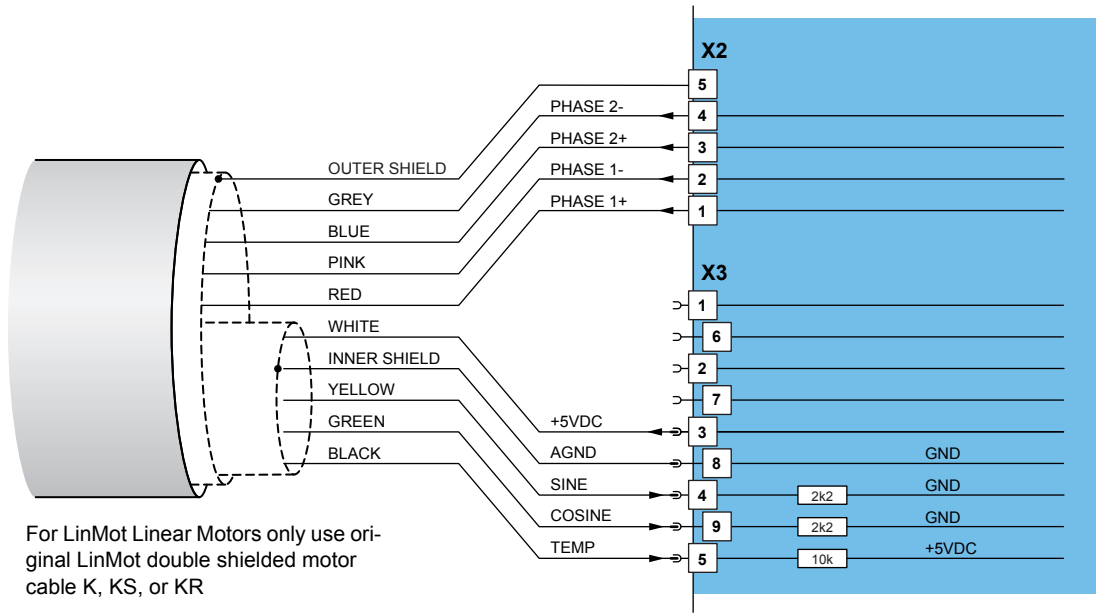

X4: 11pin

Control / Supply

- X4. 11 QuickStop, PTC2
- X4. 10 IO, PTC1
- X4. 9 IO, LIM+
- X4. 8 IO, LIM-
- X4. 7 IO, HSW
- X4. 6 IO, TRIG
- X4. 5 IO, CAP
- X4. 4 IO, AN
- X4. 3 IO, /BRK
- X4. 2 +24VDC
- X4. 1 DGND



X14 LOGIC SUPPLY / IO CONNECTION

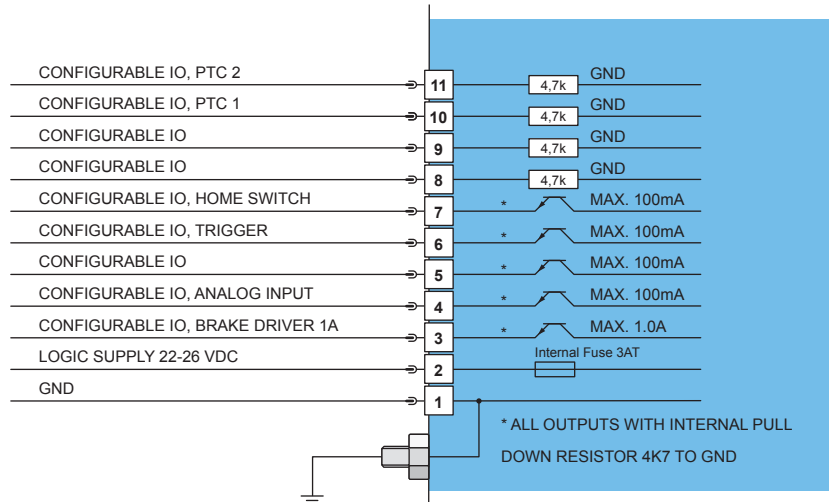

Phoenix MC1,5/12-STF-3,5
0.25-1.5mm² (AWG24-16)

X7-X8

RS485/CAN

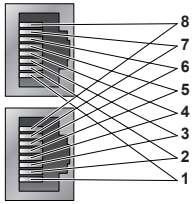

RJ-45

Nr		
1	RS485_Rx+	A
2	RS485_Rx-	B
3	RS485_Tx+	Y
4	GND	
5	GND	
6	RS485_Tx-	Z
7	CAN_H	
8	CAN_L	
Case	Shield	

- X7 internally connected to X8 (1:1 connection)
- Use twisted pair (1-2, 3-6, 4-5, 7-8) cable for wiring.
- The built in CAN and RS485 terminations can be activated by S5.

X9

Profibus DP

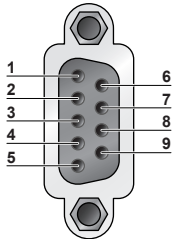

DSUB-9

Nr		
1	-	
2	-	
3	RxD/TxD-P	
4	CNTR-P	
5	GND	(galvanically seperated)
6	+5V	(galvanically seperated)
7	-	
8	RxD/TxD-N	
9	-	
Case	Shield	

Max. Baud rate: 12 Mbaud

S1-2

Address Selectors / Bus Termination

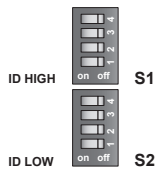

Switch		
S1	Bus ID High (0...F)	HEX-Switches for Bus ID
S2	Bus ID Low(0...F)	address range 0.255

S3

Bus Termination



Switch	C1200	
S5	Switch 1: Termination Resistor for RS485 on CMD (120R between pin 1 and 2 on X7/X8) on/off	
	Switch 2: CAN Termination on CMD (120R between pin 7 and 8 on X7/X8) on/off	
	Switch 3: Beostrap	
	Factory settings: all switches "off"	

X13

External Position Sensor Commutation

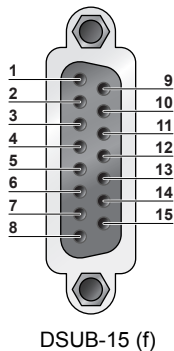

Nr	Description	
1	+5V DC	
9	A+	Encoder
2	A-	Encoder
10	B+	Encoder
3	B-	Encoder
11	Z+	Encoder
4	Z-	Encoder
12	Encoder Alarm	
5	GND	
13	U+	Commutation (Hall Switch)
6	U-	Commutation (Hall Switch)
14	V+	Commutation (Hall Switch)
7	V-	Commutation (Hall Switch)
15	W+	Commutation (Hall Switch)
8	W-	Commutation (Hall Switch)
case	Shield	

Max. Input Frequency:	12MHz (RS422 inkrementell), 40ns edge separation
Sensor Supply Current:	max. 100mA
Position Encoder Inputs:	RS422, Max Input Frequency: 2.5MHz, 5 M counts/s with quadrature decoding, 40ns edge separation
Encoder Simulated Outputs:	RS422, Max Output Frequency: 2.5MHz, 5 M counts/s with quadrature decoding, 200ns edge separation
Differential Hall Switch Inputs:	RS422, Max Input Frequency: <1kHz
Enc. Alarm In:	5V / 1mA
Sensor Supply:	5VDC, max 100mA

X33: 8pin

Safety Relays (only for -1S)

X33. 4/8 Ksr+
X33. 3/7 Ksr-
X33. 2/6 Ksr f+
X33. 1/5 Ksr f-



X33 STO RELAYS

Nr	Bez.	
4 / 8	Ksr +	Safety Relay 1 / 2 Input positive
3 / 7	Ksr -	Safety Relay 1 / 2 Input negative
2 / 6	Ksr f+	Safety Relay 1 / 2 feedback positive
1 / 5	Ksr f-	Safety Relay 1 / 2 feedback negative

X17-X18

Ethernet RealTime



RJ-45

Nr	Bez.
X17	Specification depends on RT-Bus Type. Please refer to according documentation.
X18	

X19

RS232 Configuration

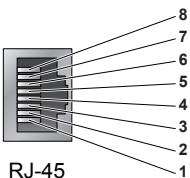

RJ-45

Nr	Bez.
1	Reserved, do not connect
2	Reserved, do not connect
3	RS232 RX
4	GND
5	GND
6	RS232 TX
7	Reserved, do not connect
8	Reserved, do not connect
case	Shield

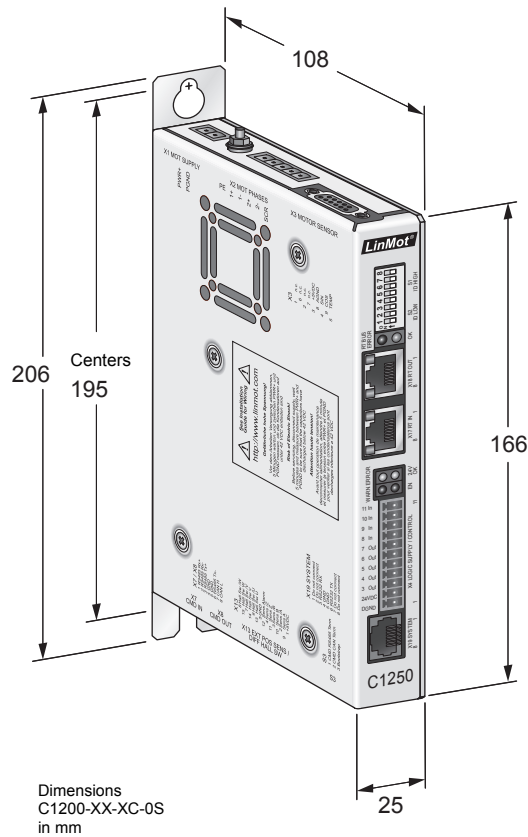

Servo Drives Series		C1200	
Width	mm (in)	25	(1.0)
Height	mm (in)	206	(8.1)
Height without fixings	mm (in)	166	(6.5)
Depth	mm (in)	108	(4.2)
Weight	kg (lb)	1.5	(3.3)
IP Protection class	IP	20	
Storage temperature	°C	-25...40	
Transport temperature	°C	-25...70	
Operating temperature	°C	0...40 at rated date 40...50 with power derating	
Max. case temperature	°C	65	
Max. power dissipation	W	30	
Min. distance between drives	mm (in)	20 (0.8)	left/right
		50 (2)	top/bottom

Item	Description	Part Number
C1200-GP-XC-0S	General Purpose Drive (72V/25A)	0150-1882
C1230-SE-XC-0S	Sercos over EtherCAT Drive(72V/25A)	0150-1897
C1250-EC-XC-0S	EtherCAT Drive (72V/25A)	0150-1884
C1250-PL-XC-0S	PowerLink Drive (72V/25A)	0150-1885
C1250-IP-XC-0S	Ethernet IP Drive (72V/25A)	0150-1886
C1250-PN-XC-0S	Profinet Drive (72V/25A)	0150-1888
C1250-SC-XC-0S	Sercos III Drive (72V/25A)	0150-1887
C1200-GP-XC-1S	General Purpose Drive (72V/25A), STO	0150-2344
C1230-SE-XC-1S	Sercos over EtherCAT Drive(72V/25A), STO	0150-2350
C1250-EC-XC-1S	EtherCAT Drive (72V/25A), STO	0150-2345
C1250-PL-XC-1S	PowerLink Drive (72V/25A), STO	0150-2347
C1250-IP-XC-1S	Ethernet IP Drive (72V/25A), STO	0150-2346
C1250-PN-XC-1S	Profinet Drive (72V/25A), STO	0150-2348
C1250-SC-XC-1S	Sercos III Drive (72V/25A), STO	0150-2349

Servo Drive B1100



Series B1100-PP

288

Series B1100-VF

290

Series B1100-GP

292

Servo Drives B1100

Series B1100 Servo Drives are compact axis drives, with 32-bit position resolution and an integrated power element, for linear motors and rotary drives.

The drives are suitable for simplest and standard positioning tasks, across the entire force range of the LinMot product range.



Connection to Machine Drive

The Series B1100 Servo Drives can be actuated by machine controls from any manufacturer or brand, via digital inputs and outputs; by RS232 or RS485 serial interface; or by CanBus CANopen and DeviceNet interfaces.

For complex motion sequences that run in an overarching positioning drive, the motor can be controlled by means of analog speed or force targets. The position signal from the measurement system integrated in the linear motor can be accessed at the encoder output to control position.

Process and sensor interfaces

Fast process interfaces for direct processing of sensor signals are available as freely programmable analog and digital inputs and fast trigger inputs.

For high-accuracy applications, a freely configurable encoder interface is available. It analyzes the commutation signals from brushless, rotary servomotors as well.

Logic and power supply

The Servo Drives have two separate power supplies for the logic and power elements.

In an E-stop and safe stop of the drive, only the power element supply is cut off from the drive. The logic supply and the drive continue to run.

This has the advantage that the drive and linear motor do not need to be reinitialized when the machine is restarted, since all process data, including the current position of the linear motor, are still up to date.

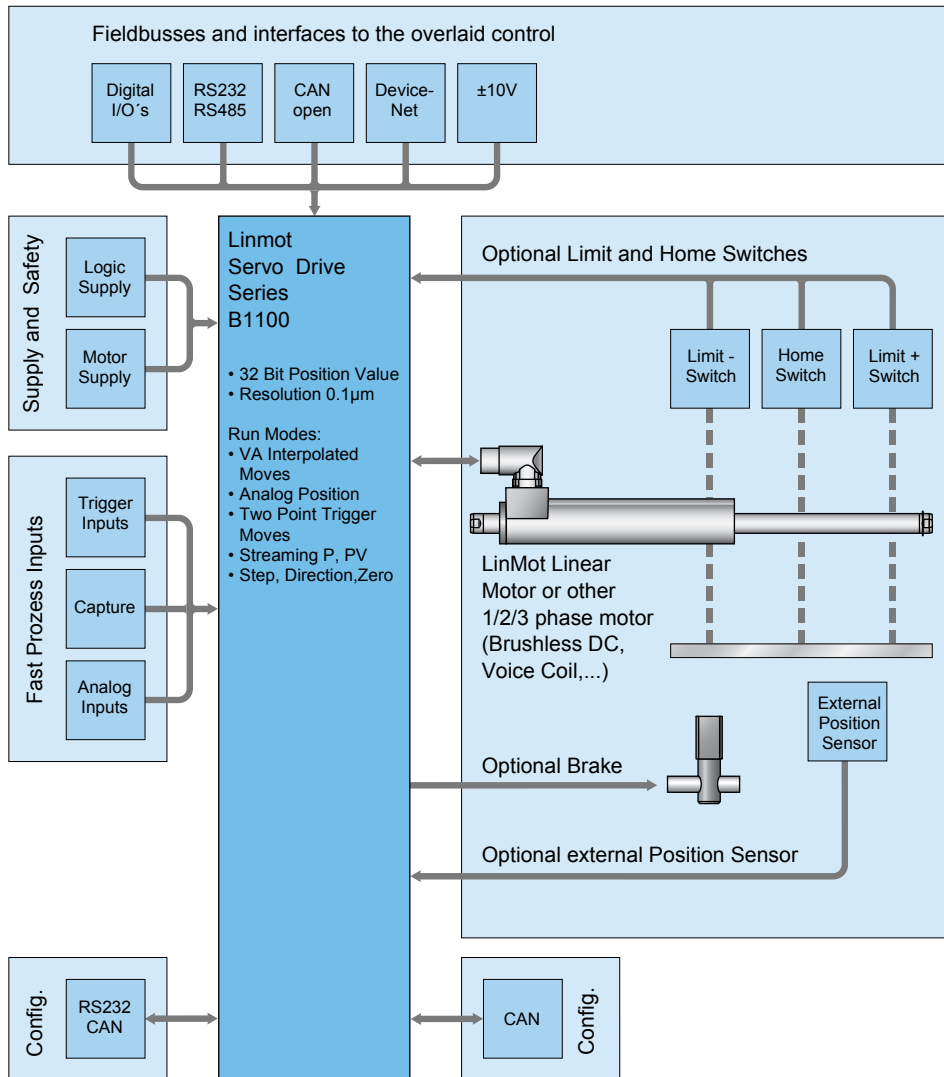

System Integration

Flexible hardware enables control of any 1/2/3-phase motors. Thus, low-power rotary servomotors, such as brushless DC motors, can be integrated in the same controls concept.

Additionally, the drives can be equipped with optional peripherals, such as reference and end stop switches, high-precision external position sensors, or a mechanical holding brake.

Series B1100 Servo Drives have analog inputs and digital inputs and outputs, serial interfaces, and fieldbus connections. The user is therefore not dependent on the selection of the overarching drive.

With flexibility and a compact form factor, LinMot Series B1100 Servo Drives provide a complete solution for a flexible drive concept in single and multiple axis applications, with linear motors and other actuators.

Diverse Korrekturen im Deutschen, siehe Korrekturen von Dani

Position Streaming

With a cyclical target value, or "position streaming," the overarching NC or CNC drive communicates with the Servo Drive through CanOpen or DeviceNet.

The position and velocity calculated in the overarching drive is transmitted to the Servo Drive cyclically. The P, PV, or PVT mode is available for this transmission.

Using the cyclical target value, complex motions and interpolating multi-axis applications can be implemented.

Motor Interfaces

The series B1100 Servo Drives allow control of 1, 2, or 3 phase linear motors and brushless rotary servomotors.

B1100 Servo Drives provide all necessary interfaces to operate linear or rotary motors with optional external peripherals, such as end position and reference switches, a mechanical brake, or a high-resolution external position sensor.

Configuration

Parameterization and configuration of the Servo Drive is done via the RS232 interface on the front side, or CANBus for simultaneous configuration of several drives..

LinMot Talk user-friendly PC software is available for configuration. In addition to on-line documentation, LinMot Talk provides extensive debugging tools, such as an oscilloscope and an error inspector, for simple and rapid start-up of the axes.

Fieldbus and Ethernet drives can also be configured directly by the overarching drive.

Position Indexing

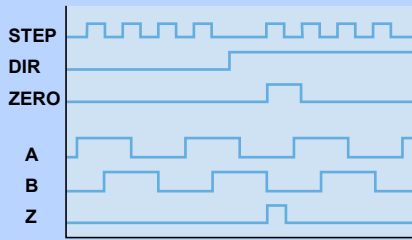

In position indexing, the linear motor is controlled like a stepper motor, using Step/Dir/Zero, or A/B signals. The step distance is freely programmable from $1.5 \times 10^{-6} \mu\text{m}$ to 3.275mm/step. The input signal can be used directly as the target position, or it can be filtered by the VA interpolator.

Operating Modes:	Step/Dir/Zero, A/B
Inputs:	differential RS422 (X13/14)
Step distance:	$1.5 \times 10^{-6} \mu\text{m}$3.275mm, 32 Bit
Max Input Frequency:	2 MHz

+/- 10V Analog Force / Velocity Control

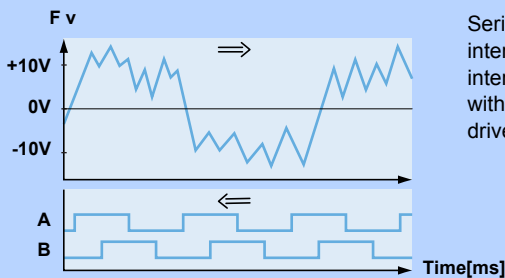

Series B1100 drives allow analog force (torque) or velocity targets to be set, via the +/- 10V interface, by an overlaid position drive. The current actual position is output via the encoder interface, with adjustable resolution, as positioning feedback. In high-precision applications with high-resolution external position sensors, the sensor signals can be passed through in the drive.

Analog Input:	-10...+10V, differential
Resolution:	Max. 12 Bit
Scanning rate:	Max. 10 kHz
Encoder Simulation:	1,2,5,10,20 μm Resolution

Setpoint Streaming

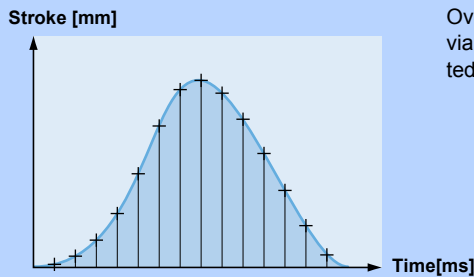

Overlaid NC drives with CANopen or DeviceNet interfaces communicate with the Servo Drives via "Position Streaming". The position and velocity calculated in the overlaid control is transmitted to the Servo Drive cyclically. The P, PV, or PVT mode is available for this transmission.

Position Resolution:	32 Bit
Velocity Resolution	32 Bit
Interpolator:	5 kHz
cycle times:	2-5ms

Analog Position

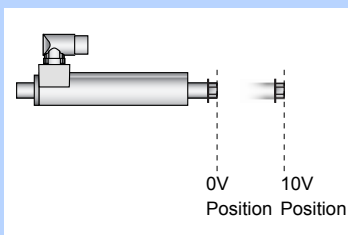

For an analog position target, the linear motor travels to a position proportional to the input voltage. The position is either scanned continuously, or only after a rising edge of the trigger signal. In order to prevent uncontrolled jumps in position, the motor travels to the positions with a programmable maximum acceleration and velocity (VA interpolator).

Inputs:	Analog Inputs (X14.20, X14.8/X14.21)
Voltage range:	0 - 10VDC (X14.20) -10 - +10VDC (X14.18/X14.21)
Resolution:	10 Bit
Scanning rate:	400 μsec

Interpolated Moves

Stroke [mm]

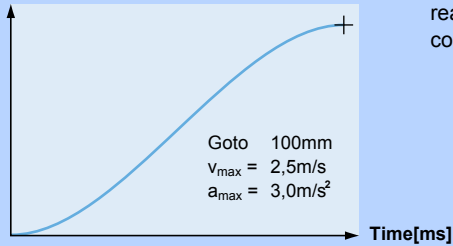

For direct position targets, using absolute or relative positioning, the desired position is reached using an acceleration and velocity-limited motion profile (VA interpolator). Positioning commands can be invoked via the serial interfaces, CANopen, DeviceNet, or a trigger input.

Stroke range:	±100m
Position Resolution:	0.1µm (32Bit)
Velocity Resolution:	1.0µm/s (32Bit)
Velocity Resolution:	10.0µm/s ² (32Bit)

Easy Steps

Input 1	Pos 125mm
Input 2	Pos 250mm
Input 3	Pos 50mm
Input 4	Pos -30mm

With the Easy Steps function, up to 6 positions or independent travel commands can be stored on the drive, and addressed via 6 serial interfaces, CANopen or DeviceNet.

Digital inputs:	max. 6
Interface:	X14
Scanning rate:	400µsec

Easy Steps Parameter Scale

Maximum Force [0...10V => 0...100%]

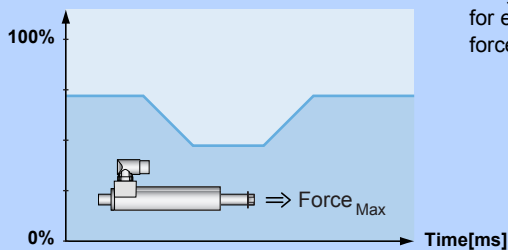

Easy Steps provide the ability to parameterize internal parameters using two analog inputs. If, for example, the maximum motor current is read at an analog input, then the maximum motor force can be provided as analog for freely programmable joining processes.

Inputs:	Analog Inputs (X14.20, X14.8/X14.21)
Voltage range:	0 - 10VDC (X14.20) -10 - +10VDC (X14.18/X14.21)
Resolution:	10 Bit
Scanning rate:	400µsec

B1100-PP
B1100-PP-HC
B1100-PP-HC-XC

- X Position Indexing
- X ±10V Force or Velocity Control
- X Setpoint Streaming (CAN)
- ✓ Analog Position Target
- ✓ MPC Commands
- ✓ Easy Step
- ✓ Easy Steps Parameter Scale
- X Serial Infaces RS232/RS485
- X CANopen
- X DeviceNet
- X Encoder Simulation

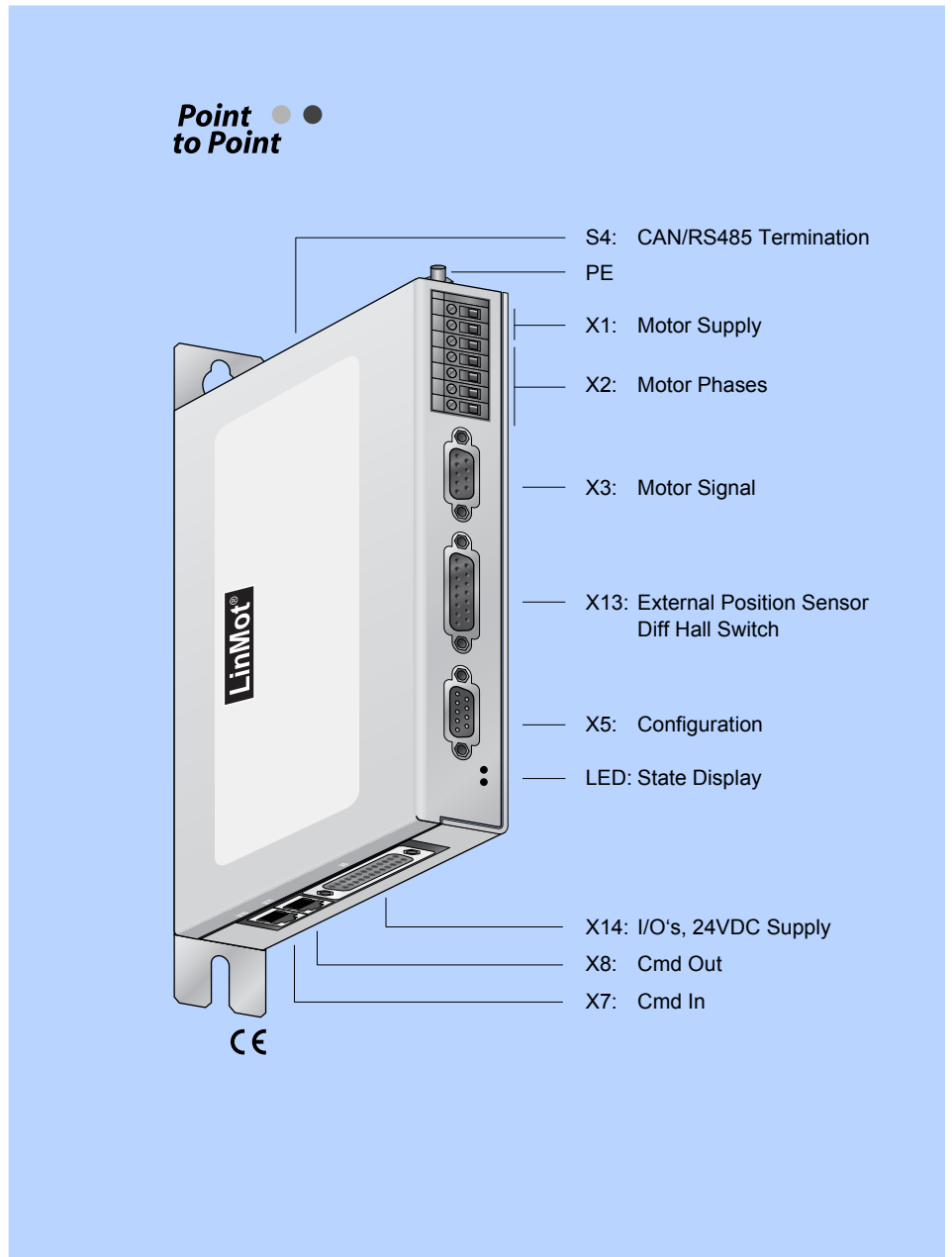

Replacing Pneumatics

Due to their simple controls via digital inputs and outputs, B1100-PP drive make excellent substitutes for pneumatic cylinders.

Using digital inputs, the linear motor can move to up to six freely programmable positions. As soon as the linear motor has reached the position, the corresponding In-Position output is actuated.

The linear motor can thus be controlled like a pneumatic cylinder with end position switches.

Easy Steps positioning commands

Using the Easy Steps function, up to six absolute or relative move commands can be stored in the drive, and invoked via six digital inputs.

Easy Steps also provide the ability to parameterize internal parameters using two analog inputs. If, for example, the maximum motor current is read at an analog input, then the maximum motor force can be provided as analog for freely programmable joining processes.

Analog Position Target

Any position can be set, using an analog 0...10V signal.

During configuration, for each position value, one input signal of 0V and 10V is programmed. Any intermediate position can then be set via the analog input signal during operation.

The dynamics can be constrained by limits on speed and acceleration.

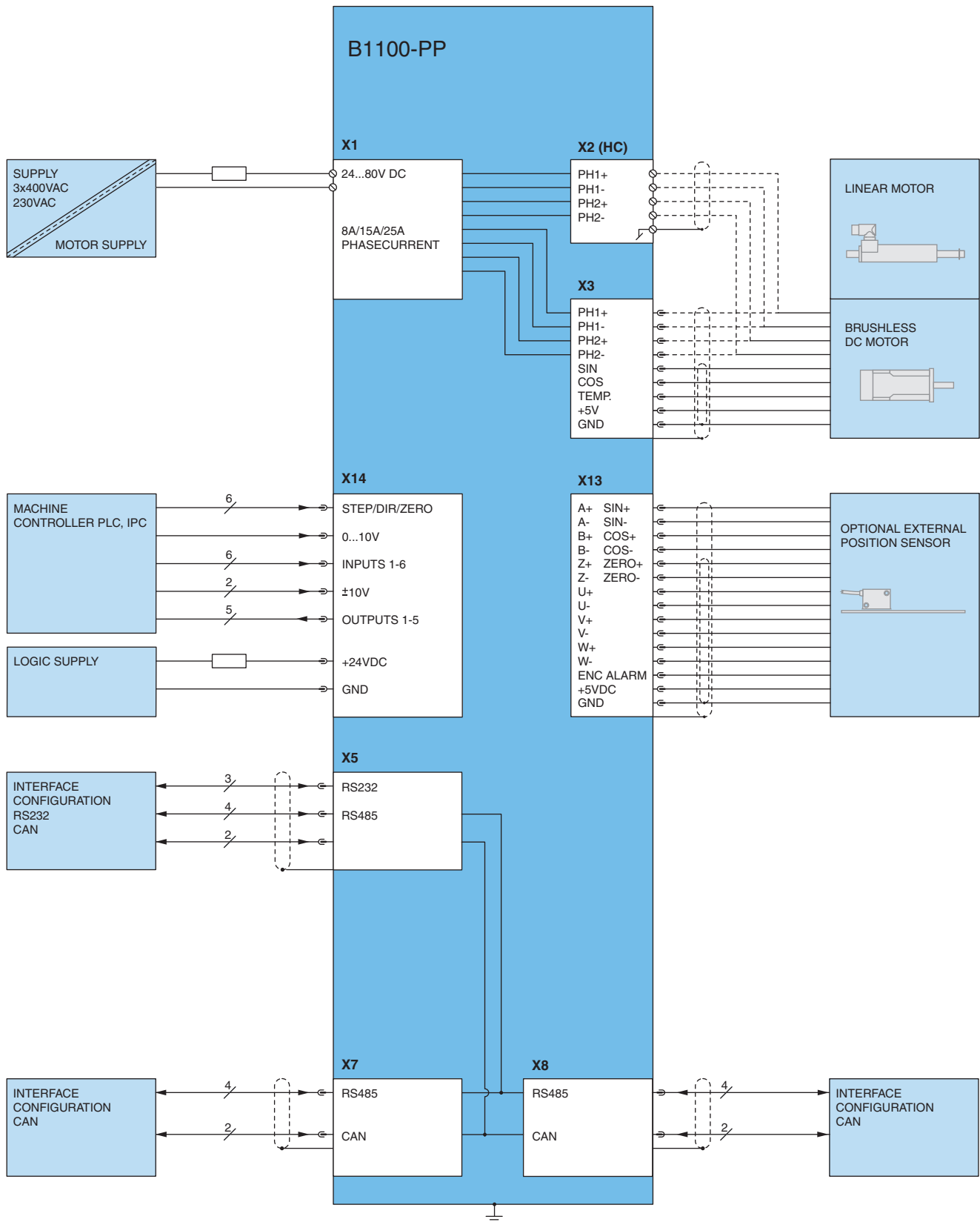

Item	Description	Part Number
B1100-PP	Point to Point Drive (72V/8A)	0150-1735
B1100-PP-HC	Point to Point Drive (72V/15A)	0150-1736
B1100-PP-XC	Point to Point Drive (72V/25A)	0150-1740

B1100-VF
B1100-VF-HC
B1100-VF-XC

- ✓ Position Indexing
- ✓ ±10V Force or Velocity Control
- ✗ Setpoint Streaming (CAN)
- ✓ Analog Position Target
- ✓ MPC Commands
- ✓ Easy Step
- ✓ Easy Steps Parameter Scale
- ✗ Serial Infaces RS232/RS485
- ✗ CANopen
- ✗ DeviceNet
- ✓ Encoder Simulation

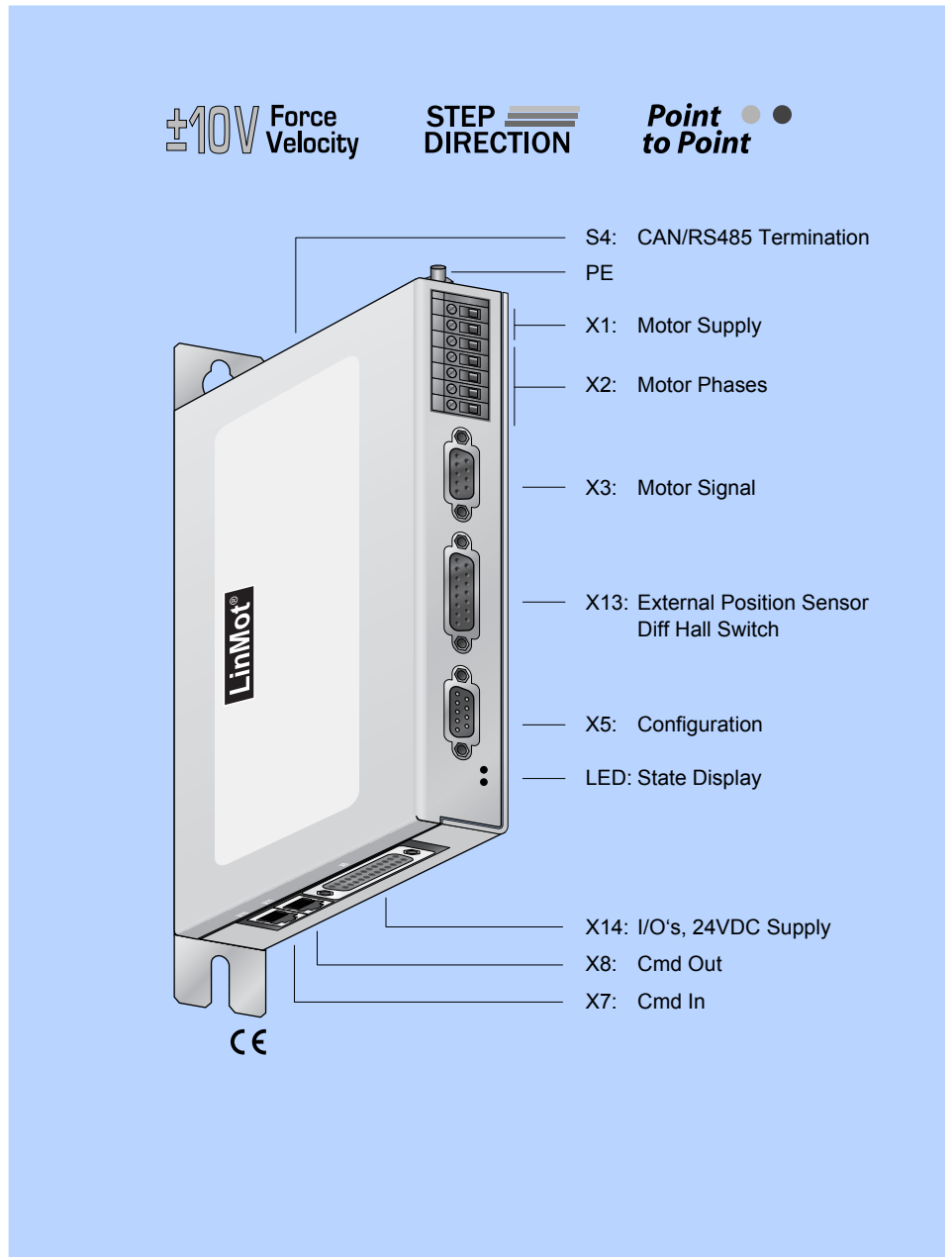

±10V 10V Force or Velocity Control,

The B1100-VF servo amplifier allows LinMot linear motors to be integrated in systems an overlaid axis drive with analog velocity (RPM) or force target (torque).

In velocity mode, the analog input voltage is used as a velocity target for the connected linear motor. The velocity control loop is closed via a PI drive in the amplifier.

In force mode, the amplifier works like a torque amplifier for rotary motors. The analog control signal is converted to a current that the VF amplifier applies to the connected motor.

Step and Direction Interface

Motor force is proportional to the current motor current (see motor data sheets for force constant *c_f*).

For step-direction targets, the target position is provided by the overlaid drive via STEP, DIRECTION, and ZERO signals.

The maximum motor current (force) can be limited via a digital input.

Encoder Simulation

No additional external sensors are needed for position measurement. The current actual position of the linear motor is captured by the integrated position measurement, and is available to the overlaid position drive as an encoder signal.

The resolution of the differential A/B encoder signals (RS422) is adjustable in the following ranges:

1µm, 2µm, 5µm, 10µm, 20µm, 50µm

If an external position sensor is used, it can be read by the B1100 amplifier.

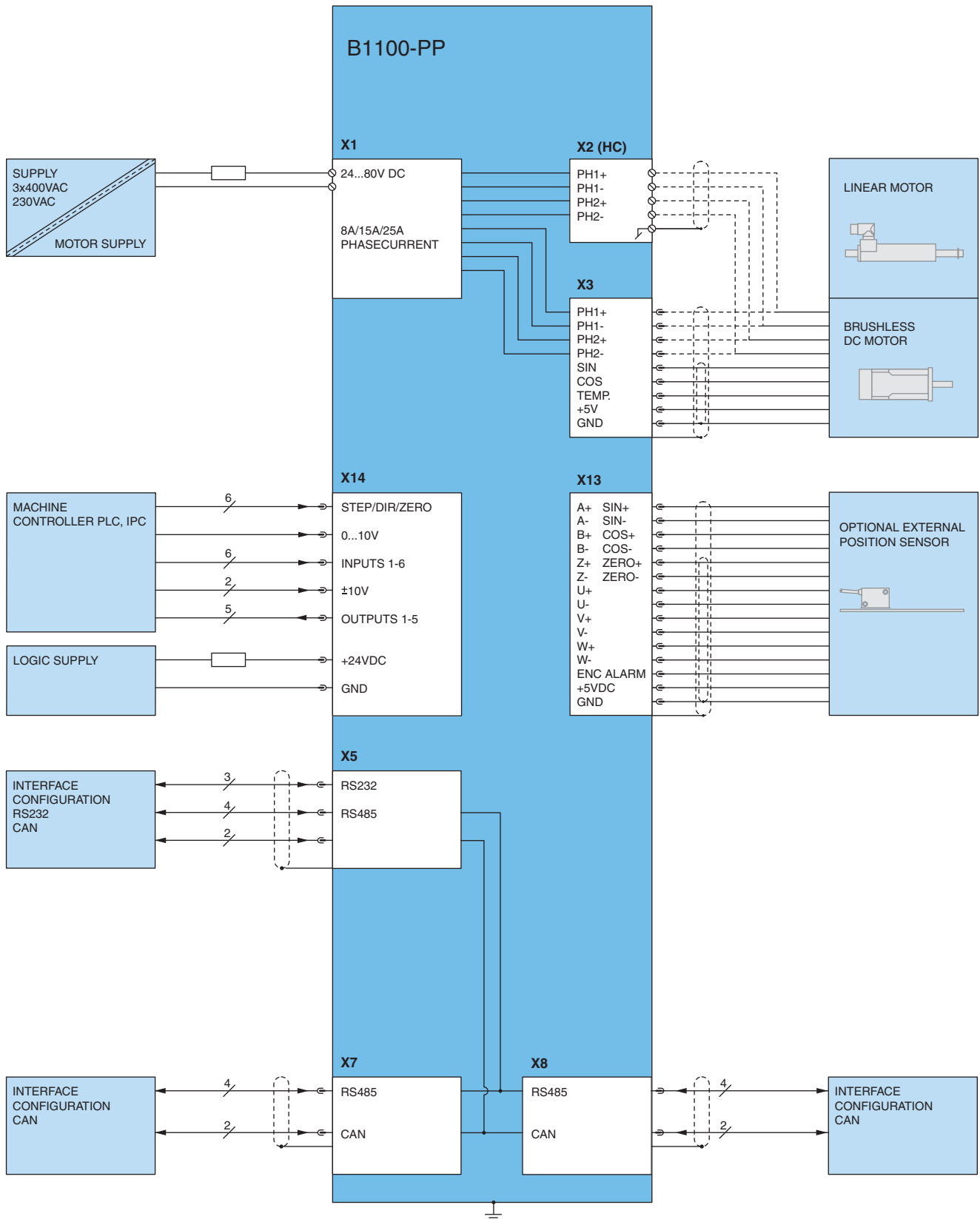

Item	Description	Part Number
B1100-VF	Force Velocity Drive (72V/4A)	0150-1685
B1100-VF-HC	Force Velocity Drive (72V/15A)	0150-1686
B1100-VF-XC	Force Velocity Drive (72V/25A)	0150-1739

B1100-GP
B1100-GP-HC
B1100-GP-XC

- ✓ Position Indexing
- ✓ ±10V Force or Velocity Control
- ✓ Setpoint Streaming (CAN)
- ✓ Analog Position Target
- ✓ MPC Commands
- ✓ Easy Step
- ✓ Easy Steps Parameter Scale
- ✓ Serial Infaces RS232/RS485
- ✓ CANopen
- ✓ DeviceNet
- ✓ Encoder Simulation

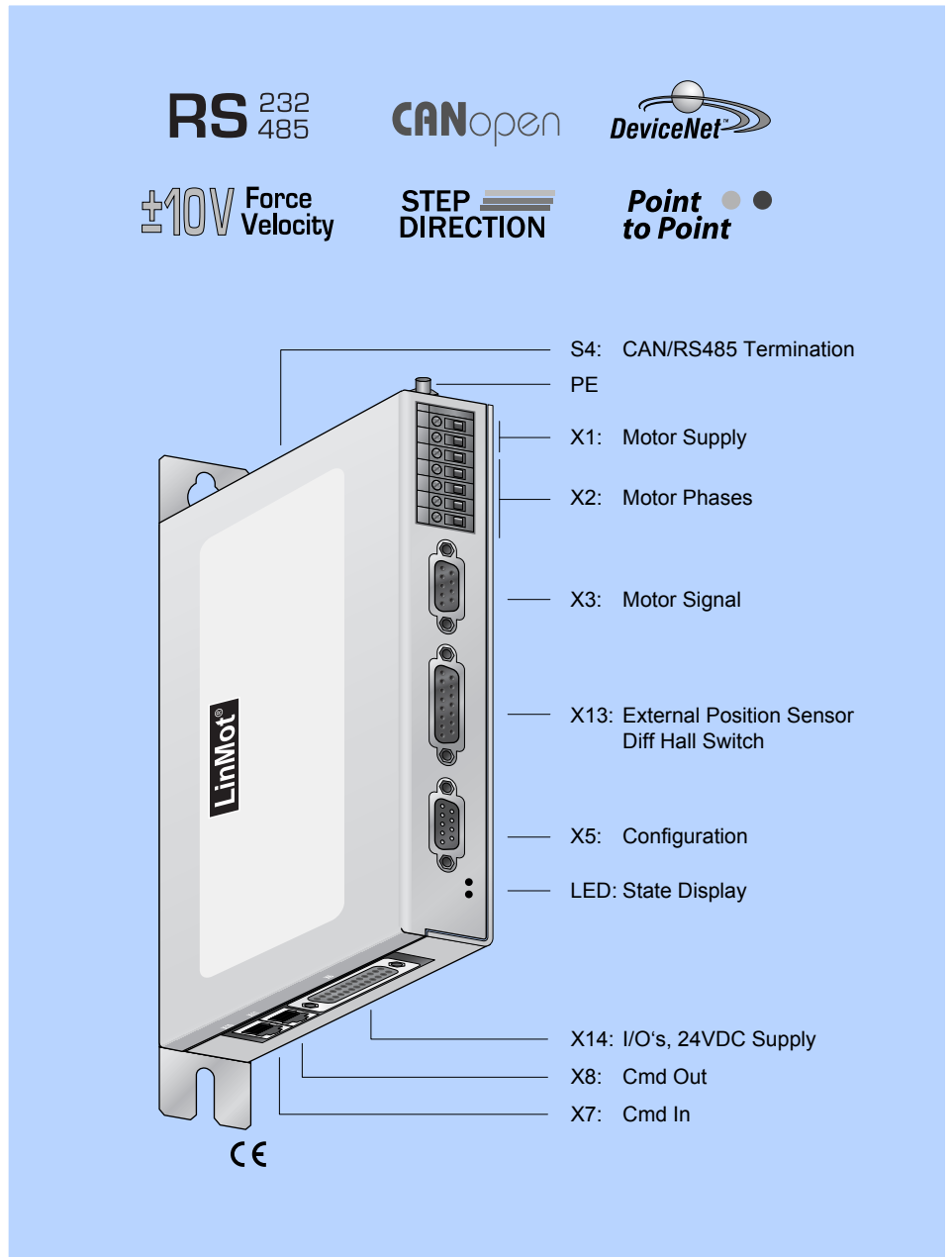

RS232 / RS485

The LinMot B1100-GP series Servo Drives support the LinRS serial communications protocol. LinRS is a proprietary protocol for actuating LinMot Servo Drives via the RS 232, RS 422, and RS 485 interfaces.

If the drive is actuated by the overarching drive via the serial interface, then this is configured from the PC via CanBus. The USBSCAN converter (item no. 0150-3134), supported by LinMot Talk, is used for this.

Adjustable baud rates: 9.6 - 115.2kBaund

CANopen

The LinMot B1100-GP drives support the CiA DS301 communications protocol.

The following resources are available:
 3 T_PDO, 3 R_PDO, 1 T_SDO, 1 R_SDO

The following protocols are supported by the CO drives:

- NMT Error Control (Nodeguarding Protocol or HeartBeat Protocol)
- PDO (Transmission type 254 and 1)
- SDO Upload and Download
- NMT (Start, Stop, Enter PreOp, Reset Node, Reset Communication) Boot-Up Message

DeviceNet

With the DeviceNet protocol, even complicated motion sequences can be realized with the highest possible flexibility.

The drive can be actuated and monitored via the DeviceNet connection.

B1100-GP are UCMM Group 3-capable slaves, and support polled IO runtime data transfer.

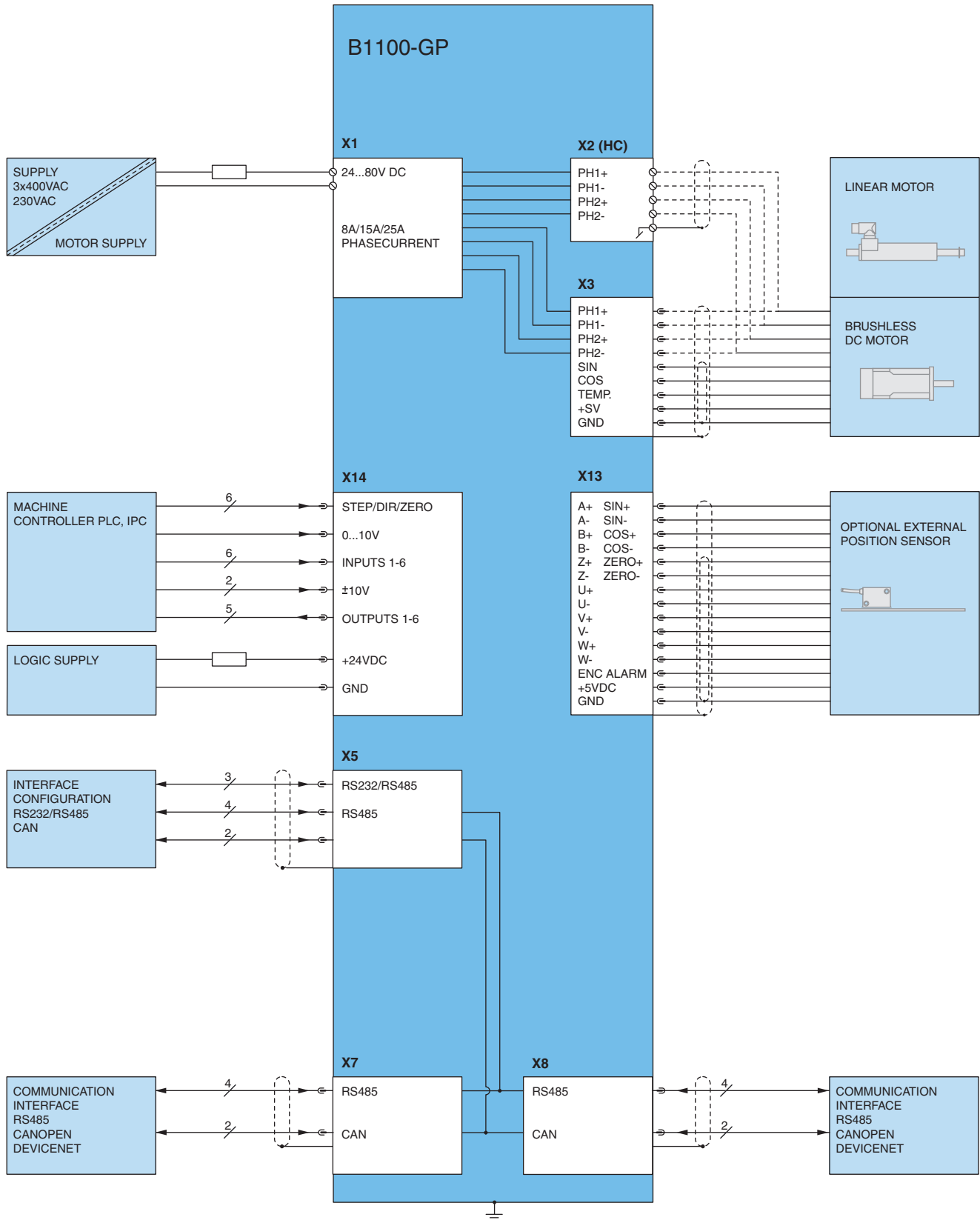

Item	Description	Part Number
B1100-GP	Point to Point Drive (72V/8A)	0150-1737
B1100-GP-HC	Point to Point Drive (72V/15A)	0150-1738
B1100-GP-XC	Point to Point Drive (72V/25A)	0150-1741

X1

Motor Supply



Screw Terminals
2.5 mm² (AWG14)

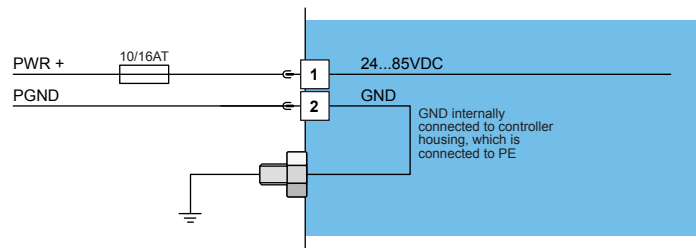

Motor Supply:

Motor Supply Voltage 24...85VDC.
Absolute max. Rating 72VDC + 20%

External fusing: 10AT for LC (8Apeak Servos), 16AT for HC and XC (15/25Apeak) Servos



If motor supply voltage is exceeding 90VDC, the drive will go into error state

X2

Motor Phases

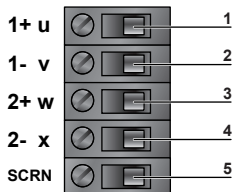

Screw Terminals
1.5-2.5mm²
(AWG16-14)

Nr.	Designation	LinMot Linear Motor	Color	3-Phase-Motor
1	PH1+ /U	Motor Phase 1+	red	Motor Phase U
2	PH1- /V	Motor Phase 1-	pink	Motor Phase V
3	PH2+ /W	Motor Phase 2+	blue	Motor Phase W
4	PH2- /	Motor Phase 2-	grey	
5	SCRN	Shield		

The motor phases on X2 and X3 are internally connected.

If the RMS current is higher than 5A RMS, the phases must be connected to X2 and not to X3.

X3

Motor

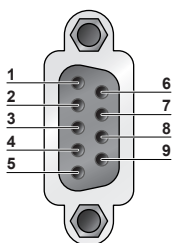

DSUB-9

Nr	LinMot Linear Motor	3-Phase-Motor
1	Motor Phase 1+	Motor Phase U
2	Motor Phase 2+	Motor Phase W
3	+5VDC	
4	Sine	Hall U
5	Temperature	Hall W
6	Motor Phase 1-	Motor Phase V
7	Motor Phase 2-	
8	AGND	
9	Cosine	Hall V
Case	Shield	

- Use X3 for motor phase wiring if phase current does not exceed 2Arms or 4Apeak

- X3.3 (+5VDC) may be used only to supply motor hall-effect sensors (max. 100mA).

- X3.8 (AGND) may be used only to supply motor hall-effect sensors, and must not be connected to GND externally

Motor

Motor wiring

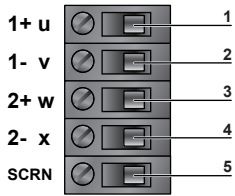

X2: Screw Terminals

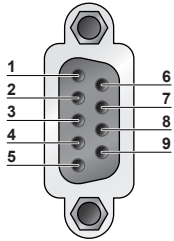

X3: DSUB-9 (f)

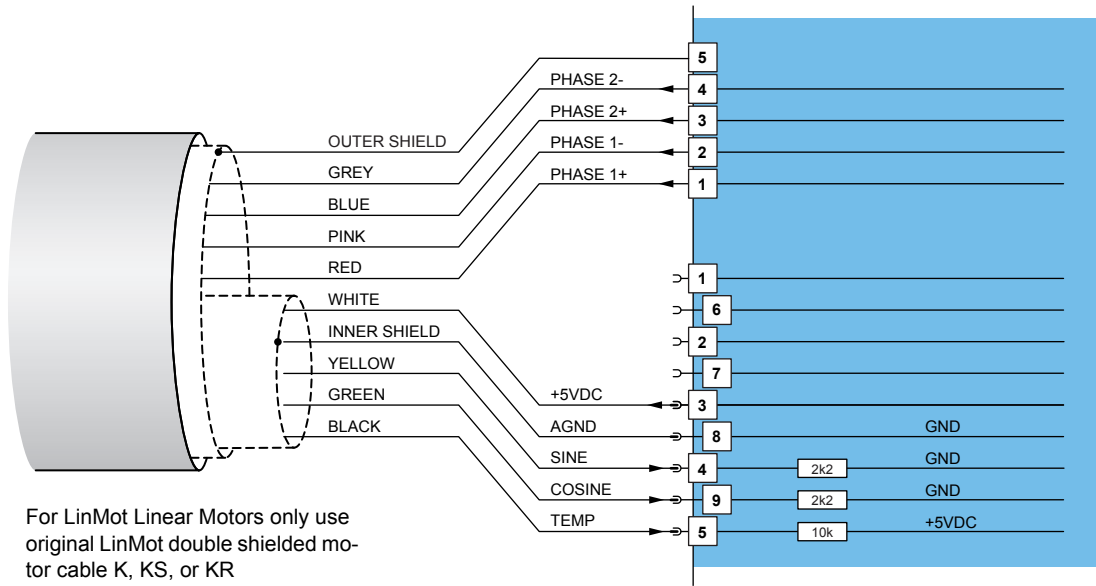

Motor

Motor wiring for phase current below 2Arms and below 4Apeak

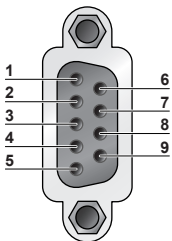

X3: DSUB-9 (f)

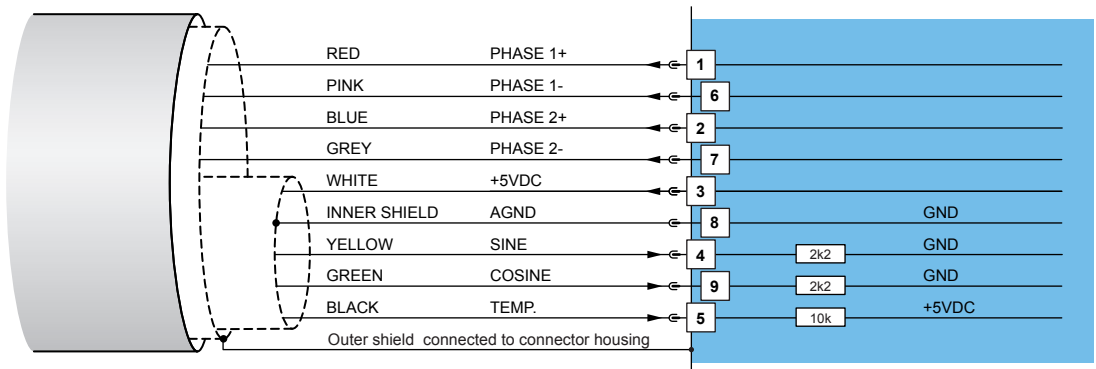

S4

Bus Termination



Switch		
S4	Switch 1: RS232 (switch "off" / RS485 "on")	Select serial RS23 or RS485
	Switch 2: Termination RS485 on/off	
	Switch 3: Termination CAN on/off	
	Switch 4: Bootstrap	Factory settings: all switches "off"

X5 COM

COM Schnittstelle

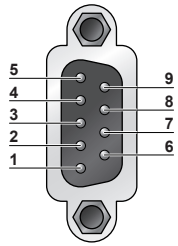

X5: DSUB-9 (m)

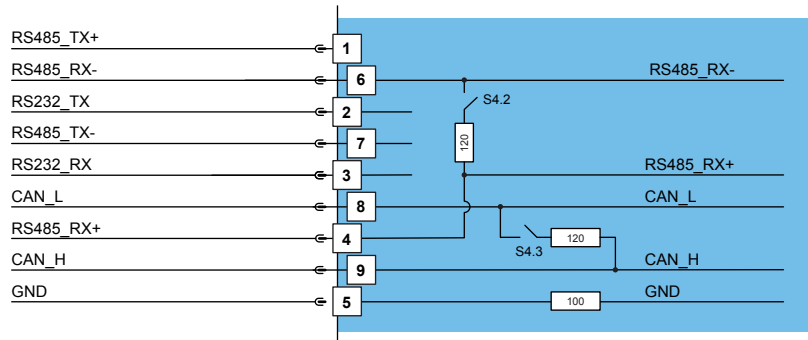

RS232: Configuration on all Drives: use 1:1 connection cable to PC

LED

State Display

Green:

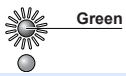

24VDC Logic Supply OK

Red:



State: Error
Blinking: Fatal Error

X7-X8

RS485/CAN

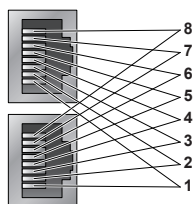

RJ-45

Nr		
1	RS485_Rx+	A
2	RS485_Rx-	B
3	RS485_Tx+	Y
4	GND	
5	GND	
6	RS485_Tx-	Z
7	CAN_H	
8	CAN_L	
Case	Shield	

- X7 internally connected to X8 (1:1 connection)
- Use twisted pair (1-2, 3-6, 4-5, 7-8) cable for wiring.
- The built in CAN and RS485 terminations can be activated by S3.2 and S3.3.

X13

External Position Sensor Commutation

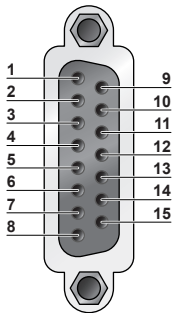

DSUB-15 (f)

Nr	Description	
1	+5V DC	
9	A+	Encoder
2	A-	Encoder
10	B+	Encoder
3	B-	Encoder
11	Z+	Encoder
4	Z-	Encoder
12	Encoder Alarm	
5	GND	
13	U+	Commutation
6	U-	Commutation
14	V+	Commutation
7	V-	Commutation
15	W+	Commutation
8	W-	Commutation
case	Shield	

Max. Input Frequency: 2MHz (incremental RS422), 240ns edge separation

Sensor Supply Current: max. 100mA

Position Encoder Inputs: RS422, Max Input Frequency: 2MHz, 4 M counts/s with quadrature decoding, 240ns edge separation

Encoder Simulated Outputs:RS422, Max Output Frequency: 2.5MHz, 5 M counts/s with quadrature decoding, 200ns edge separation

Differential Hall Switch Inputs: RS422, Max Input Frequency: <1kHz

Enc. Alarm In: 5V / 1mA

Sensor Supply: 5VDC, max 100mA

X14

Digital I/O

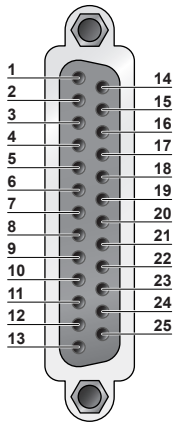

X14: DSUB-25 (f)

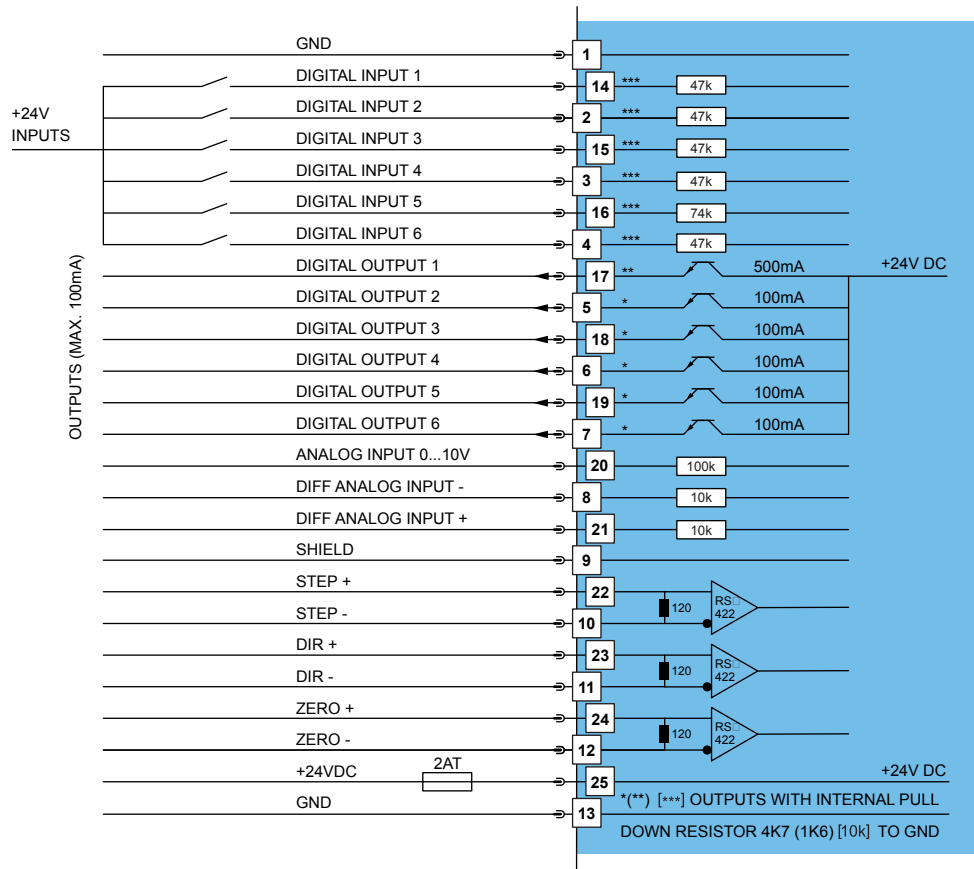

Logic Supply:	Switch Mode Power Supply:24VDC (22...26VDC)
	External Fuse: 2AT
All Digital Inputs:	Direct interfacing to digital 24VDC PLC outputs.
	Input Current: 1mA
	Logic Levels: Low Level: guaranteed: -5 to 5VDC, typically < 8VDC
	High Level: guaranteed: 20...30VDC, typically > 16VDC
	Sample Rate: 400us
All Digital Outputs:	Short circuit and overload protected high side switches
	Voltage: 24VDC
	Sample Rate: 400us
	Max. Current: 100mA / 500mA (X14.17)
	Peak Current: 370mA / 1100mA (X14.17)
	Outputs may directly drive inductive loads.
Analog Input on X14.20:	Range: 0V..+10V 10Bit ADC
	Sample Rate: 400us
Differential Analog Input on X14.8 X14.21 X14.9	Range: -10V..+10V 10Bit ADC
Shield:	Sample Rate: 400us
Differential Step Dir Zero:	Indexer Inputs: RS422
	Max. Input Frequency: 2MHz
	4 M counts/s with quadrature decoding, 240ns edge separation
Cable length:	<30m

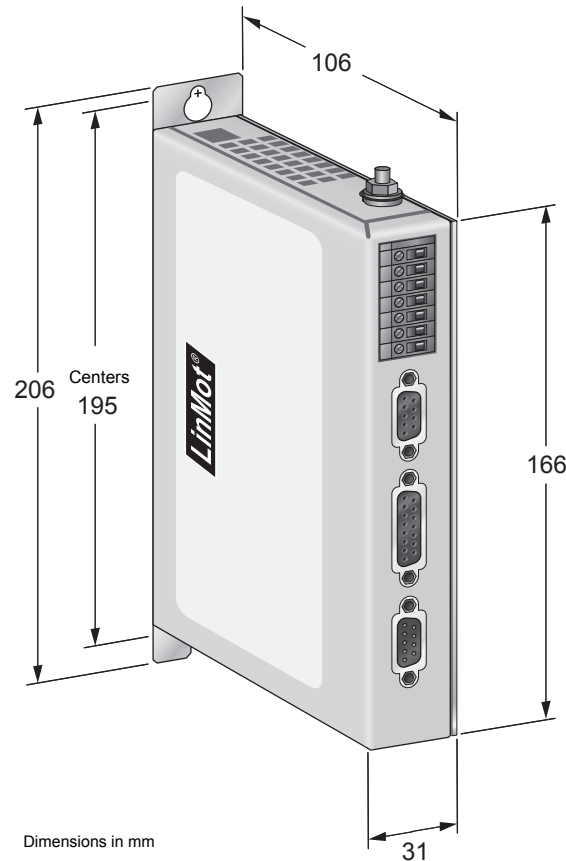

Servo Drive Series B1100		
Width	mm (in)	31 (1.3)
Height	mm (in)	166 (6.6)
Height without fixings	mm (in)	206 (8.1)
Depth	mm (in)	106 (4.2)
Weight	g (lb)	700 (1.6)
IP Protection class	IP	20
Storage temperature	°C	-25...40
Transport temperature	°C	-25...70
Operating temperature	°C	0...40 at rated date 40...50 with power derating
Max. case temperature	°C	70
Max. power dissipation	W	30
Min. distance between drives	mm (in)	20 (0.8) left/right 50 (2) top/bottom

Item	Description	Part Number
B1100-PP	Point to Point Drive (72V/8A)	0150-1735
B1100-PP-HC	Point to Point Drive (72V/15A)	0150-1736
B1100-PP-XC	Point to Point Drive (72V/25A)	0150-1740
B1100-VF	Force Velocity Drive (72V/8A)	0150-1685
B1100-VF-HC	Force Velocity Drive (72V/15A)	0150-1686
B1100-VF-XC	Force Velocity Drive (72V/25A)	0150-1739
B1100-GP	Point to Point Drive (72V/8A)	0150-1737
B1100-GP-HC	Point to Point Drive (72V/15A)	0150-1738
B1100-GP-XC	Point to Point Drive (72V/25A)	0150-1741

Switched-Mode Power Supplies

115VAC / 230VAC

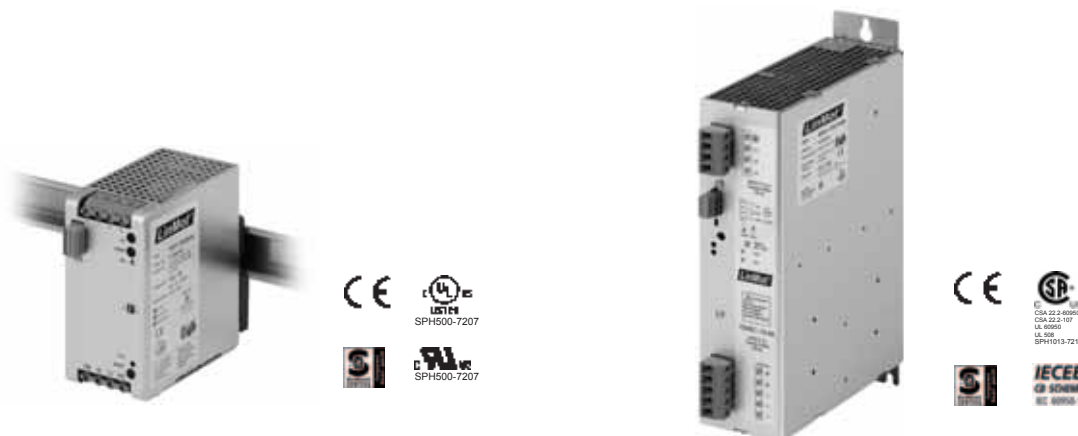

Item	Description	Part Number
S01-72/500	Switched-Mode Power Supply 72V/500W	0150-1874
S01-72/1000	Switched-Mode Power Supply 72V/1000W	0150-1872

Transformer Supply T01

3x230/280/400/480VAC



Item	Description	Part Number
T01-72/420...1500-Multi	Transformer Supply 3x230/280/400/480VAC, 50/60Hz, 420...1500W	see page 532

Control Box B01-E1100



Item	Description	Part Number
B01-E1100	Control Box for E1100 (incl. cable and connectors)	0150-1970
B01-B1100	Control Box for B1100 (incl. cable and connectors)	0150-2110

Connector Cable and USB-Converter



Item	Description	Part Number
RS232 PC config. cabel 2m	for E100/E1001/E1100/B1100	0150-3307
USB-Serial Converter	USB to 9-pin Serial Converter	0150-3110
USB-CAN Converter	USB to CAN Converter for E1100/B1100	0150-3134
RJ45-08/0.3	RJ45 patch cable 0.3m for E1100/B1100	0150-1852
RJ45-08/0.6	RJ45 crossover patch cable 0.6m	0150-1853

Option: External High Resolution Encoder



Item	Description	Part Number
MS01-1/D	Linear Encoder 1um, A/B (for 1mm magnetic band)	0150-1840
MB01-1000	Magnetic Band 1mm pitch, per cm	0150-1963

Multi Axes System B1150 / B8050



Servo Drive B1150-ML

428

Bus Module B8050-ML

430

Multi-Axes System B1150 / B8050

Series B1150 Servo Drives are compact axis drives, with 32-bit position resolution and an integrated power element, for LinMot P01 linear motors and rotary servo motors.

B1150 drives together with the bus modules B8050 are designed for cost optimized, modular multi axes systems with the industrial Ethernet interfaces EtherCAT, Profinet, EthernetIP, Sercos III and Powerlink.



Connection to Machine Drive

The Series B1150 Servo Drives can be actuated by machine controls from any manufacturer or brand, via industrial Ethernet.

For complex motion sequences that run in an overarching positioning drive, the motor can be controlled by means of analog speed or force targets. The position signal from the measurement system integrated in the linear motor can be accessed at the encoder output to control position.

Process and sensor interfaces

Fast process interfaces for direct processing of sensor signals are available as freely programmable analog and digital inputs and fast trigger inputs.

For high-accuracy applications, a freely configurable encoder interface is available. It analyzes the commutation signals from brushless, rotary servomotors as well.

Logic and power supply

The Servo Drives have two separate power supplies for the logic and power elements.

In an E-stop and safe stop of the drive, only the power element supply is cut off from the drive. The logic supply and the drive continue to run.

This has the advantage that the drive and linear motor do not need to be reinitialized when the machine is restarted, since all process data, including the current position of the linear motor, are still up to date.

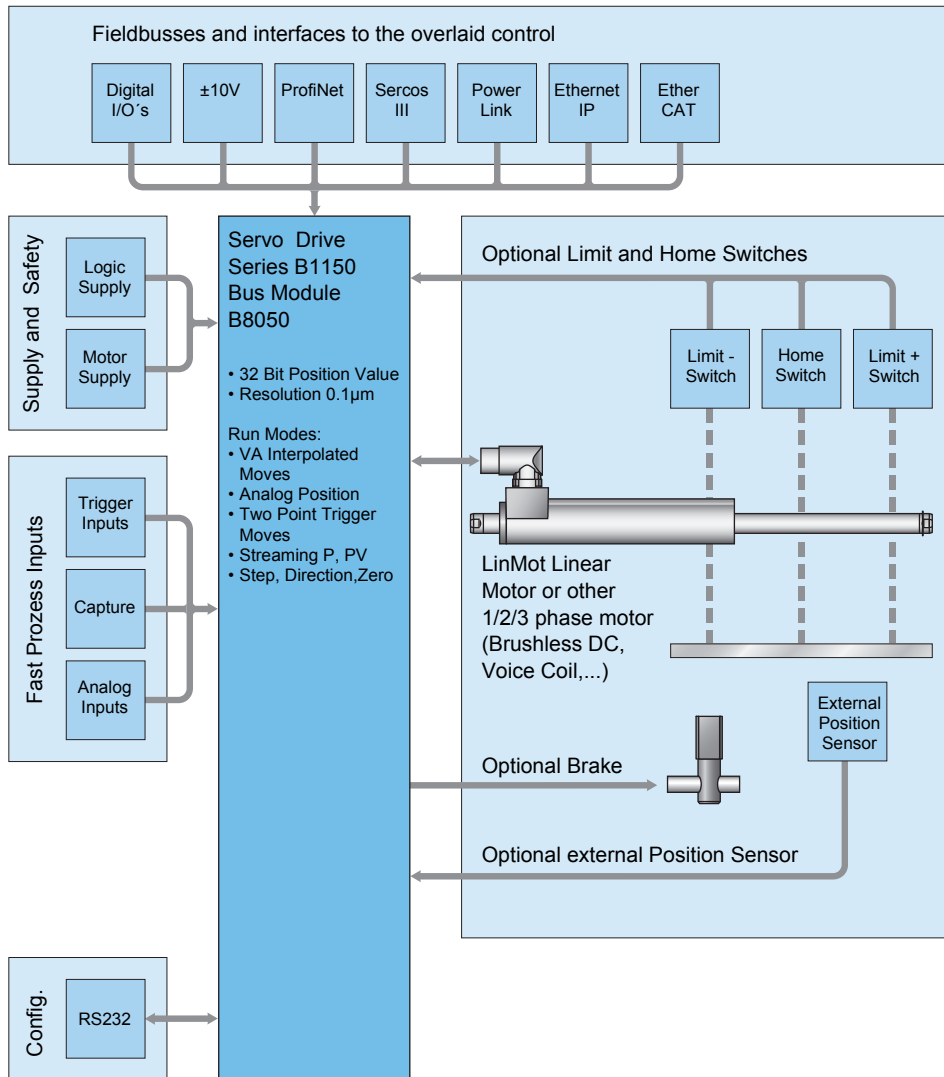

System Integration

Flexible hardware enables control of any 1/2/3-phase motors. Thus, low-power rotary servomotors, such as brushless DC motors, can be integrated in the same controls concept.

Additionally, the drives can be equipped with optional peripherals, such as reference and end stop switches, high-precision external position sensors, or a mechanical holding brake.

Series B1150 Servo Drives have analog inputs and digital inputs and outputs, serial interfaces, and fieldbus connections. The user is therefore not dependent on the selection of the overarching drive.

With flexibility and a compact form factor, LinMot Series B1150 Servo Drives provide a complete solution for a flexible drive concept in single and multiple axis applications, with linear motors and other actuators.

Diverse Korrekturen im Deutschen, siehe Korrekturen von Dani

Position Streaming

With a cyclical target value, or "position streaming," the overarching NC or CNC drive communicates with the Servo Drive via industrial Ethernet.

The position and velocity calculated in the overarching drive is transmitted to the Servo Drive cyclically. The P, PV, or PVT mode is available for this transmission.

Using the cyclical target value, complex motions and interpolating multi-axis applications can be implemented.

Motor Interfaces

The series B1150 Servo Drives allow control of 1, 2, or 3 phase linear motors and brushless rotary servomotors.

B1150 Servo Drives provide all necessary interfaces to operate linear or rotary motors with optional external peripherals, such as end position and reference switches, a mechanical brake, or a high-resolution external position sensor.

Configuration

Parameterization and configuration of the Servo Drive is done via the RS232 interface on the front side.

LinMot Talk user-friendly PC software is available for configuration. In addition to on-line documentation, LinMot Talk provides extensive debugging tools, such as an oscilloscope and an error inspector, for simple and rapid start-up of the axes.

Fieldbus and Ethernet drives can also be configured directly by the overarching drive.

Interpolated Moves

Stroke [mm]

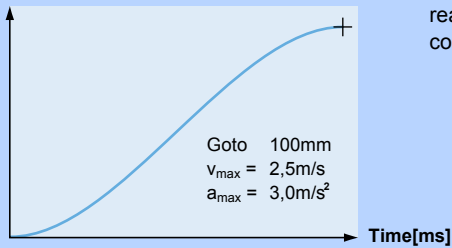

For direct position targets, using absolute or relative positioning, the desired position is reached using an acceleration and velocity-limited motion profile (VA interpolator). Positioning commands can be invoked via industrial Ethernet, or a trigger input.

Stroke range: $\pm 100\text{m}$
 Position Resolution: $0.1\mu\text{m}$ (32Bit)
 Velocity Resolution: $1.0\mu\text{m/s}$ (32Bit)
 Velocity Resolution: $10.0\mu\text{m/s}^2$ (32Bit)

Setpoint Streaming

Stroke [mm]

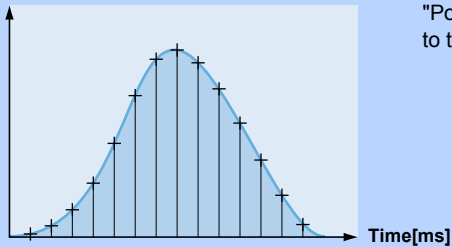

Overlaid NC drives with industrial Ethernet interfaces communicate with the Servo Drives via "Position Streaming". The position and velocity calculated in the overlaid control is transmitted to the Servo Drive cyclically. The P, PV, or PVT mode is available for this transmission.

Position Resolution: 32 Bit
 Velocity Resolution: 32 Bit
 Interpolator: 5 kHz
 cycle times: 2-5ms

Easy Steps

Input 1	Pos 125mm
Input 2	Pos 250mm
Input 3	Pos 50mm
Input 4	Pos -30mm

With the Easy Steps function, up to 6 positions or independent travel commands can be stored on the drive, and addressed via 6 serial interfaces or industrial Ethernet.

Digital inputs: max. 6
 Interface: X14
 Scanning rate: 400µsec / 2µsec with Ethernet

Easy Steps Parameter Scale

Maximum Force [0...10V => 0...100%]

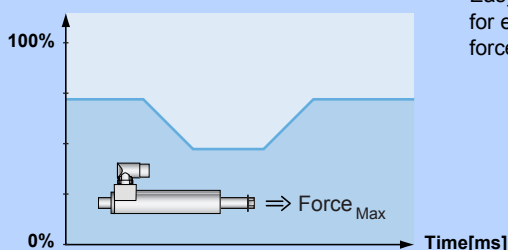

Easy Steps provide the ability to parameterize internal parameters using two analog inputs. If, for example, the maximum motor current is read at an analog input, then the maximum motor force can be provided as analog for freely programmable joining processes.

Inputs: Analog Inputs (X14.20, X14.8/X14.21)
 Voltage range: 0 - 10VDC (X14.20)
 -10 - +10VDC (X14.18/X14.21)
 Resolution: 10 Bit
 Scanning rate: 400µsec



1-Axes



2-Axes



3-Axes



4-Axes



5-Axes



6-Axes



7-Axes



8-Axes

B1150-ML
B1150-ML-HC
B1150-ML-XC

- Interpolated Moves
- Setpoint Streaming P
- Setpoint Streaming PV
- Setpoint Streaming PVT
- Easy Step
- Easy Steps Parameter Scale
- Encoder Simulation

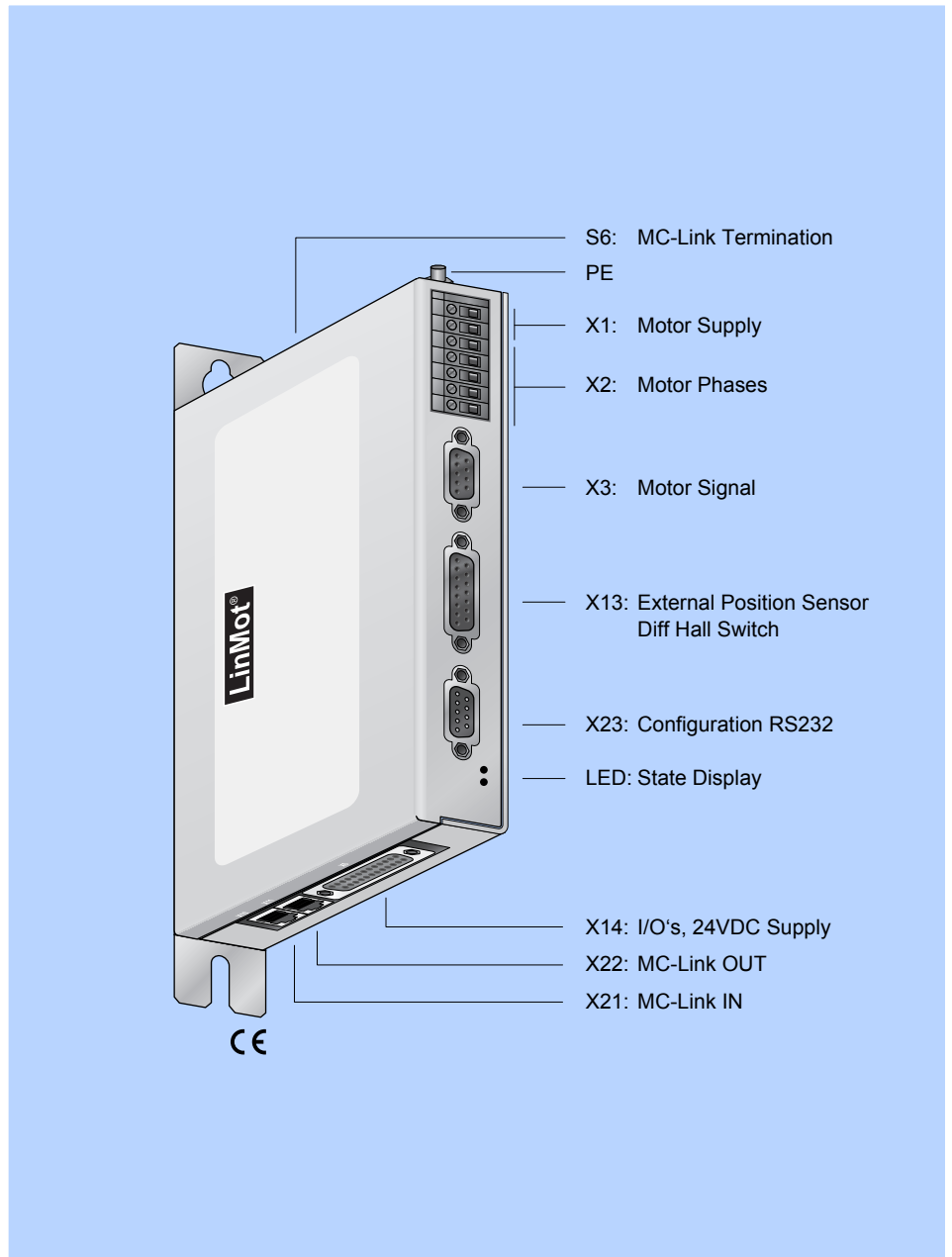

Industrial Ethernet

LinMot B1150-ML series Servo Drives together with the bus modules B8050-ML support the following industrial Ethernet Interfaces:

- EtherCat
- Ethernet IP
- Powerlink
- Profinet
- Sercos III

Modular Multi Axes Systems

The modular B1150/B8050 system is designed for multi axes applications and integration in industrial Ethernet communication from different PLC or NC manufacturers over a single bus node.

Up to 8 B1150-ML drives may be connected to a bus module B8050 and controlled over industrial Ethernet interfaces.

Interfaces

B1100 Servo Drives provide all necessary interfaces to operate linear or rotary motors with optional external peripherals, such as end position and reference switches or a mechanical brake.

Using digital inputs, the linear motor can move to up to six freely programmable positions. The resolution of the high resolution A/B/Z encoder input or A/B encoder simulation output is adjustable.

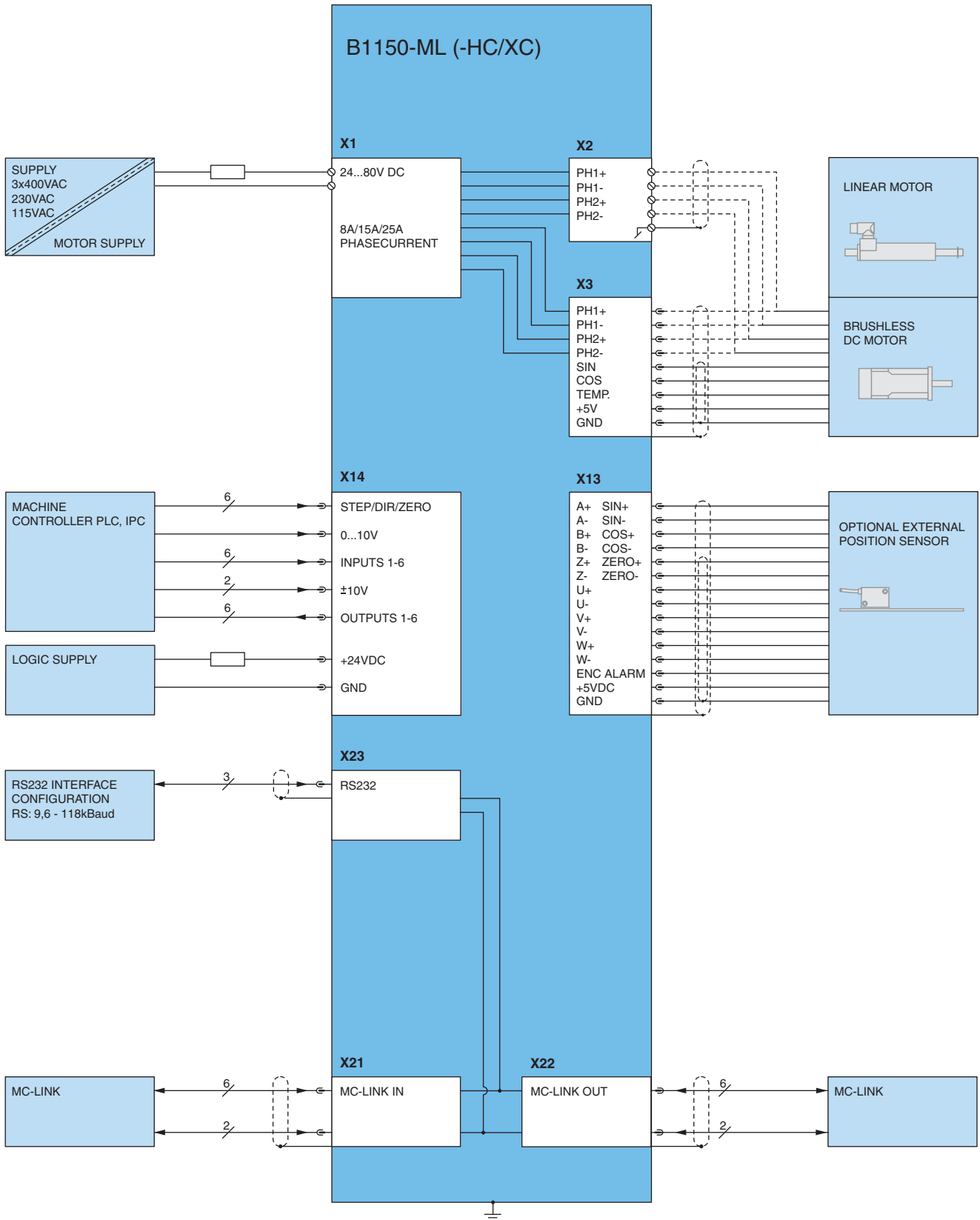

Item	Description	Part Number
B1150-ML	MC-Link Drive (72V/8A)	0150-1796
B1150-ML-HC	MC-Link Drive (72V/15A)	0150-1797
B1150-ML-XC	MC-Link Drive (72V/25A)	0150-1798

B8050-ML-EC
B8050-ML-IP
B8050-ML-PL
B8050-ML-PN
B8050-ML-SC

- ✓ Industrial Ethernet Interfacing
- ✓ Multi Axes Interfacing
- ✓ EtherCAT
- ✓ Ethernet IP
- ✓ Powerlink
- ✓ Profnet
- ✓ Sercos III

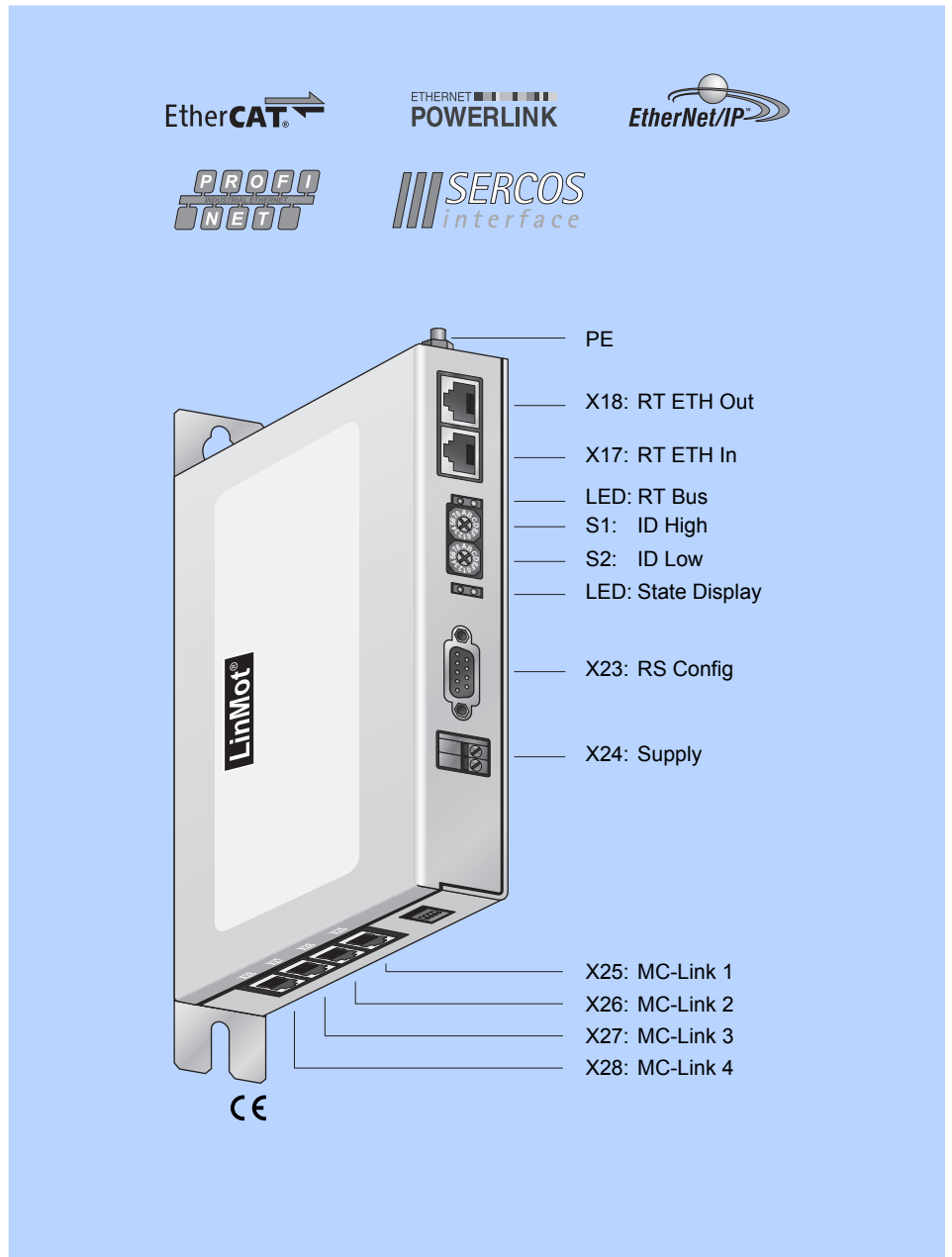

Modular Multi Axes Systems

The modular B1150/B8050 system is designed for multi axes applications and integration in industrial Ethernet communication from different PLC or NC manufacturers over a single bus node.

Up to 8 B1150-ML drives may be connected to a bus module B8050 and controlled over industrial Ethernet interfaces.

Industrial Ethernet

LinMot B8050-ML bus modules support the following industrial Ethernet Interfaces:

- EtherCat
- Ethernet IP
- Powerlink
- Profinet
- Sercos III

Motion Commands

Motion commands for the B1150/B8050 multi axes systems are identical to the B1100 motion commands.

For simple positioning tasks, relative and absolute position commands with velocity and acceleration limitation are available. For more complex motions or synchronization, the motion profiles are calculated in the overlaid drive and transmitted via set-point streaming.

8 Axes System

TOP
Termination
Settings



BOTTOM

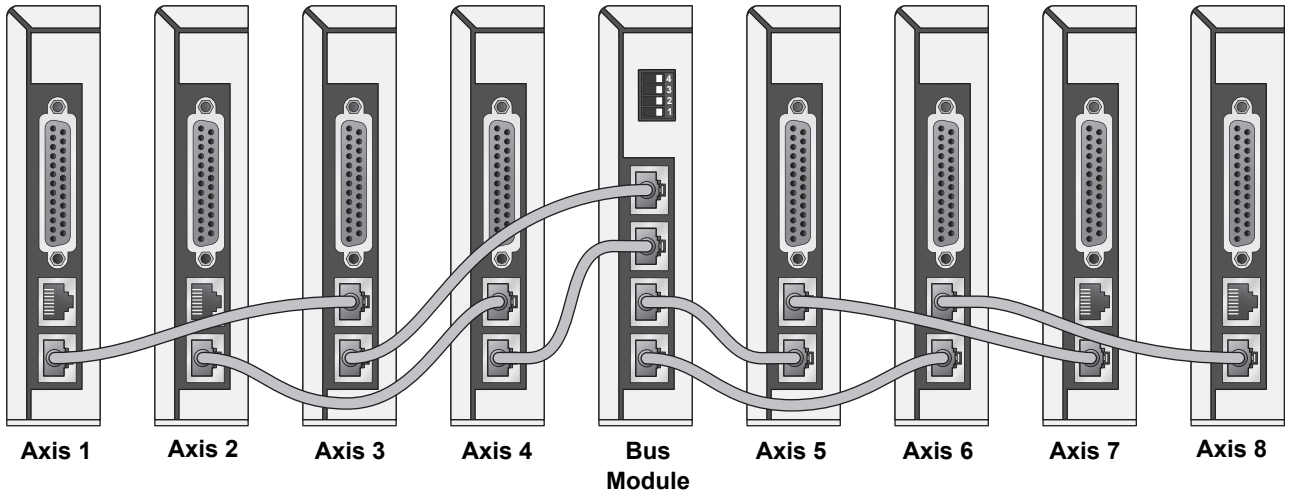

4 Axes System

TOP
Termination
Settings



BOTTOM

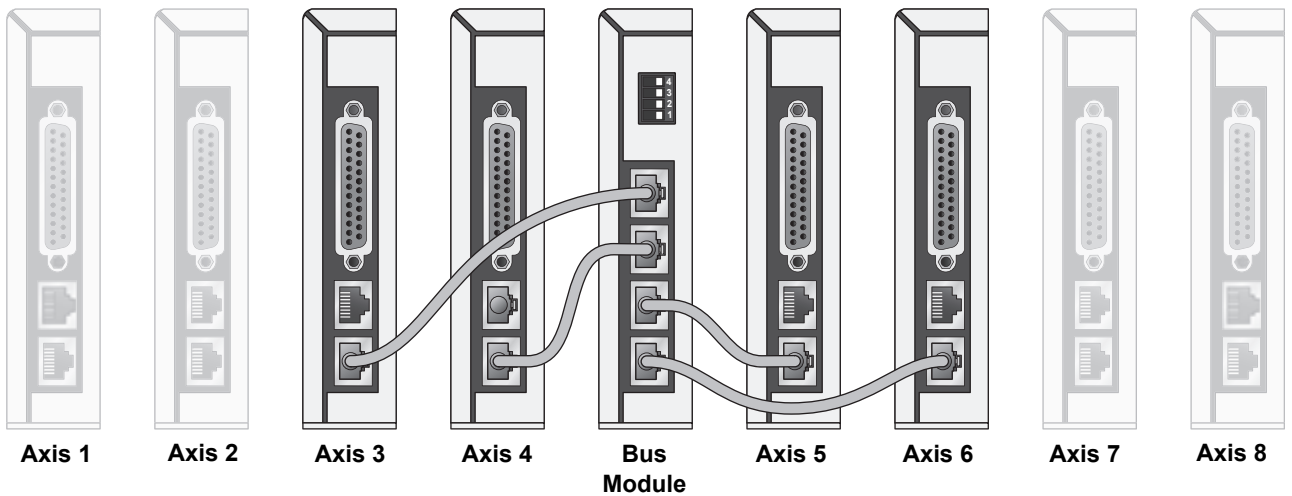

Item	Description	Part Number
B8050-ML-EC	8-Axes Bus Module Etercat	0150-1878
B8050-ML-IP	8-Axes Bus Module Ethernet IP	0150-1879
B8050-ML-PL	8-Axes Bus Module Powerlink	0150-1877
B8050-ML-PN	8-Axes Bus Module Profinet	0150-1880
B8050-ML-SC	8-Axes Bus Module Sercos III	0150-1881

X1

Motor Supply



Screw Terminals
2.5 mm² (AWG14)

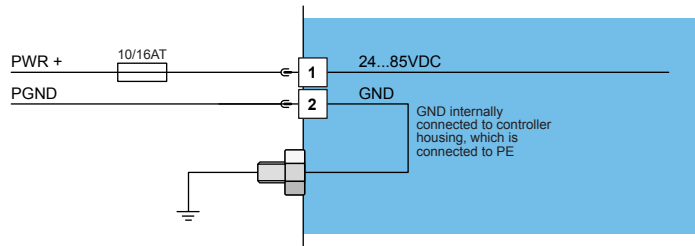

Motor Supply:

Motor Supply Voltage 24...85VDC.
Absolute max. Rating 72VDC + 20%

External fusing: 10AT for LC (8Apeak Servos), 16AT for HC and XC (15/25Apeak) Servos



If motor supply voltage is exceeding 90VDC, the drive will go into error state

X2

Motor Phases

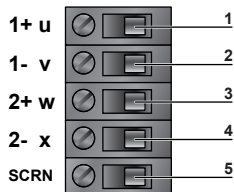

Screw Terminals
1.5-2.5mm²
(AWG16-14)

Nr.	Designation	LinMot Linear Motor	Color	3-Phase-Motor
1	PH1+ /U	Motor Phase 1+	red	Motor Phase U
2	PH1- /V	Motor Phase 1-	pink	Motor Phase V
3	PH2+ /W	Motor Phase 2+	blue	Motor Phase W
4	PH2- /	Motor Phase 2-	grey	
5	SCRN	Shield		

The motor phases on X2 and X3 are internally connected.

If the RMS current is higher than 5A RMS, the phases must be connected to X2 and not to X3.

X3

Motor

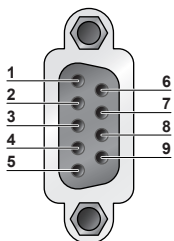

DSUB-9

Nr	LinMot Linear Motor	3-Phase-Motor
1	Motor Phase 1+	Motor Phase U
2	Motor Phase 2+	Motor Phase W
3	+5VDC	
4	Sine	Hall U
5	Temperature	Hall W
6	Motor Phase 1-	Motor Phase V
7	Motor Phase 2-	
8	AGND	
9	Cosine	Hall V
Case	Shield	

- Use X3 for motor phase wiring if phase current does not exceed 2Arms or 4Apeak

- X3.3 (+5VDC) may be used only to supply motor hall-effect sensors (max. 100mA).

- X3.8 (AGND) may be used only to supply motor hall-effect sensors, and must not be connected to GND externally

Motor | Motor wiring

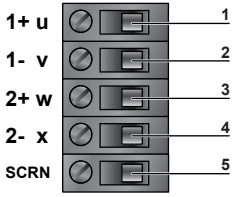

X2: Screw Terminals

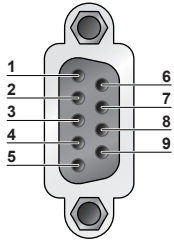

X3: DSUB-9 (f)

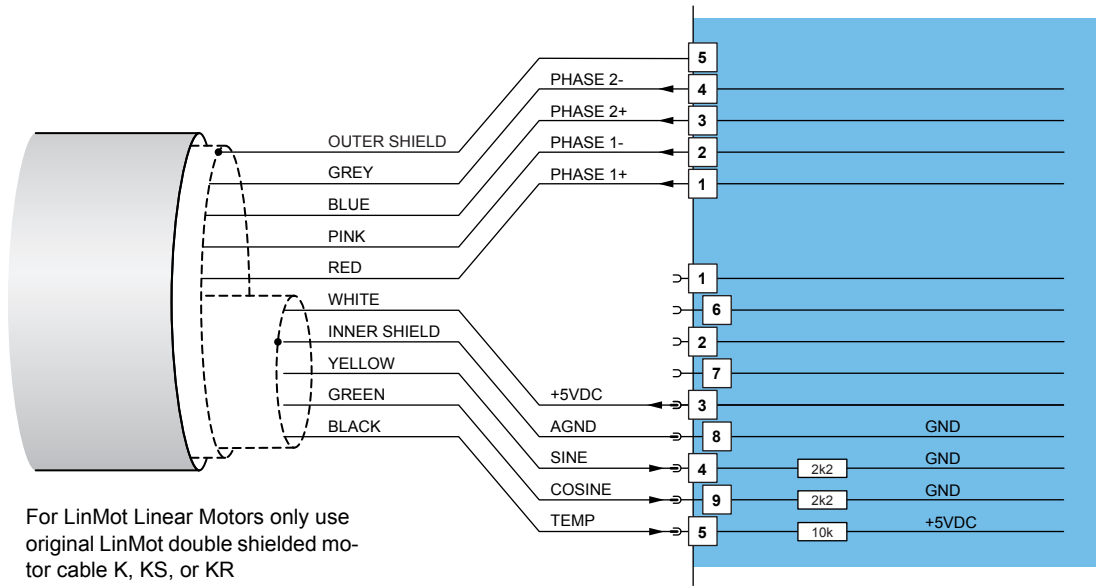

Motor | Motor wiring for phase current below 2Arms and below 4Apeak

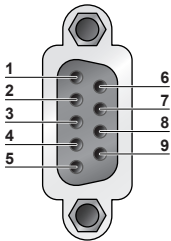

X3: DSUB-9 (f)

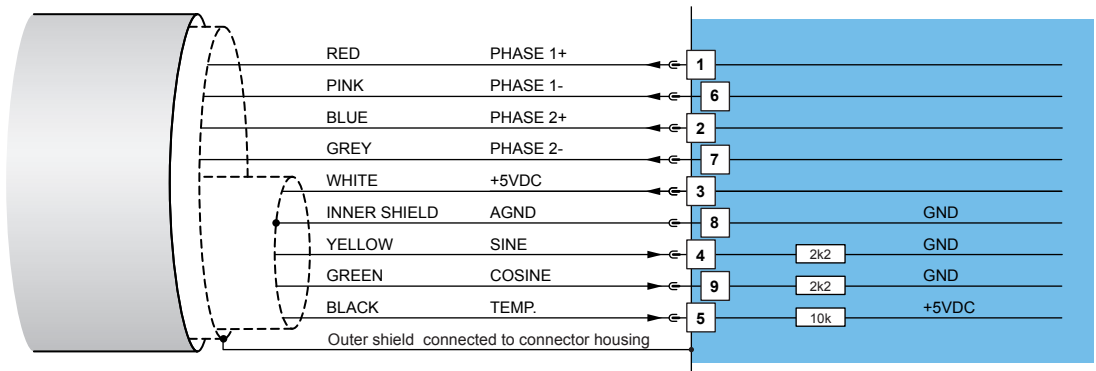

S6 | MC-Link Termination



S6

Switch		
S6	Switch 4: Bootstrap Switch 3: Termination A on/off Switch 2: Termination B on/off Switch 1: Not used	Factory settings: Switch 3 "on" all other switches "off"

X3

Motor

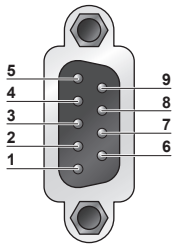

DSUB-9 (m)

Nr	
1	(Do not connect)
2	RS232_Tx
3	RS232_Rx
4	(Do not connect)
5	GND
6	(Do not connect)
7	(Do not connect)
8	(Do not connect)
9	(Do not connect)
Case	Shield

RS232:

Configuration on all drives: use 1:1 connection cable to PC with only 2,3 and 5 connected.
Use LinMot RS Config Cable (Art.-No. 0150-3307)

LED

State Display

Green:



Green

24VDC Logic Supply OK

Red:



Red

State: Error

Blinking: Fatal Error

X21-X22

MC-Link

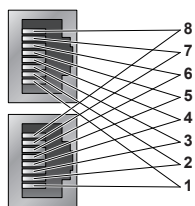

RJ-45

Nr	
1	ML 1+
2	ML1-
3	ML2+
4	Cable Select
5	GND
6	ML2-
7	ML3+
8	ML3-
Case	Shield

Use MC-Link cables (Art.-No. 0150-3308)

X13

External Position Sensor Commutation

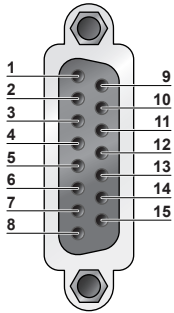

DSUB-15 (f)

Nr	Description	
1	+5V DC	
9	A+	Encoder
2	A-	Encoder
10	B+	Encoder
3	B-	Encoder
11	Z+	Encoder
4	Z-	Encoder
12	Encoder Alarm	
5	GND	
13	U+	Commutation
6	U-	Commutation
14	V+	Commutation
7	V-	Commutation
15	W+	Commutation
8	W-	Commutation
case	Shield	

Max. Input Frequency: 2MHz (incremental RS422), 240ns edge separation

Sensor Supply Current: max. 100mA

Position Encoder Inputs: RS422, Max Input Frequency: 2MHz, 4 M counts/s with quadrature decoding, 240ns edge separation

Encoder Simulated Outputs:RS422, Max Output Frequency: 2.5MHz, 5 M counts/s with quadrature decoding, 200ns edge separation

Differential Hall Switch Inputs: RS422, Max Input Frequency: <1kHz

Enc. Alarm In: 5V / 1mA

Sensor Supply: 5VDC, max 100mA

X17-X18

RealTime Ethernet 10/100 Mbit/s

X17 in



X18 out

RJ-45

Nr	Bez.
X17	Internal 2-Porto 10BASE-TX Ethernet Switch with Auto MDIX.
X18	

Specification depends on RT-Bus Type. Please refer to according documentation

X24

Supply

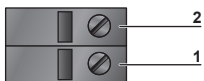

Nr	Bez.
2	+24VDC Supply (22-26VDC).
2	GND Supply

Supply 24V / typ. 150mA

Stripping Length: 10mm, Connection in acc. with standard:EN-VDE,

Use 60/75°C Copper Conductors only, Conductor cross-section max. 1.5mm²

X14

Digital I/O

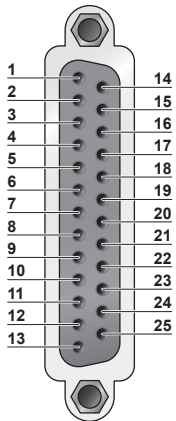

X14: DSUB-25 (f)

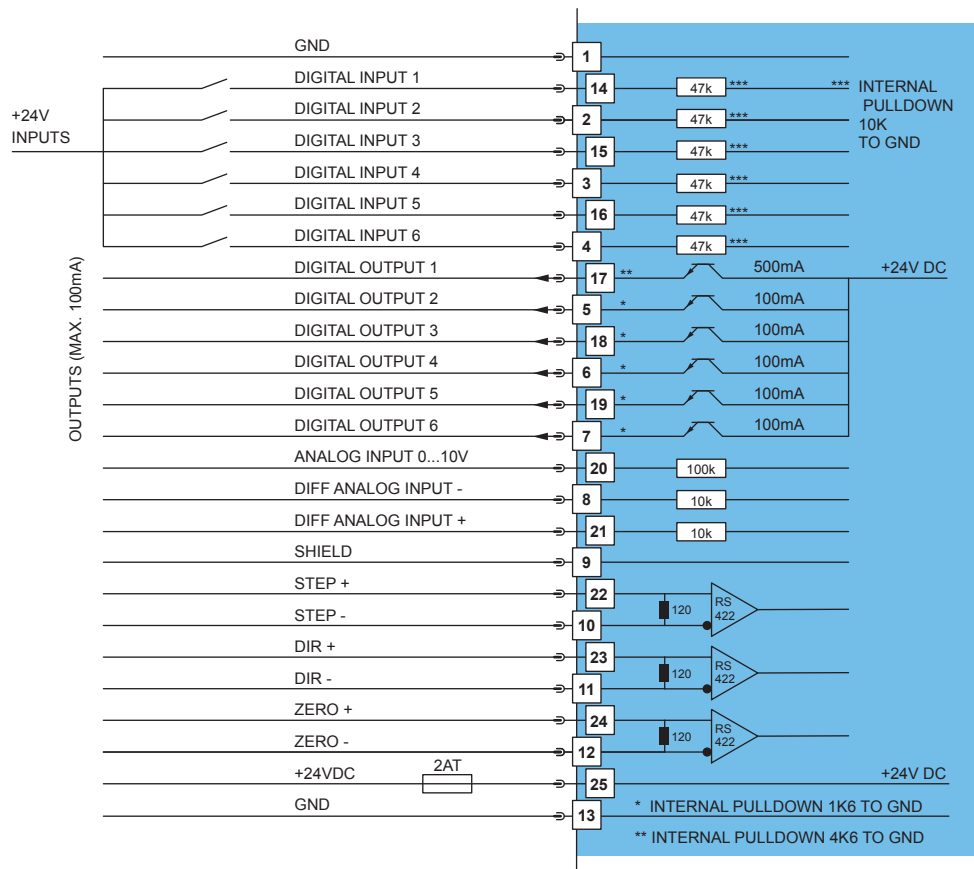

Logic Supply:	Switch Mode Power Supply:24VDC (22...26VDC)
	External Fuse: 2AT
All Digital Inputs:	Direct interfacing to digital 24VDC PLC outputs.
	Input Current: 1mA
	Sample Rate: 400us
All Digital Outputs:	Short circuit and overload protected high side switches
	Voltage: 24VDC Max. Current: 100mA/500mA (X14.17)
	Update Rate: 400us
	Outputs may directly drive inductive loads.
Analog Input on X14.20:	Range: 0V..+10V 10Bit ADC
	Sample Rate: 400us
Differential Analog Input on X14.8 X14.21 X14.9	Range: -10V..+10V 10Bit ADC
	Sample Rate: 400us
Shield:	
Differential Step Dir Zero: Indexer Inputs:	RS422
	Max. Input Frequency: 2MHz
	4 M counts/s with quadrature decoding, 240ns edge separation

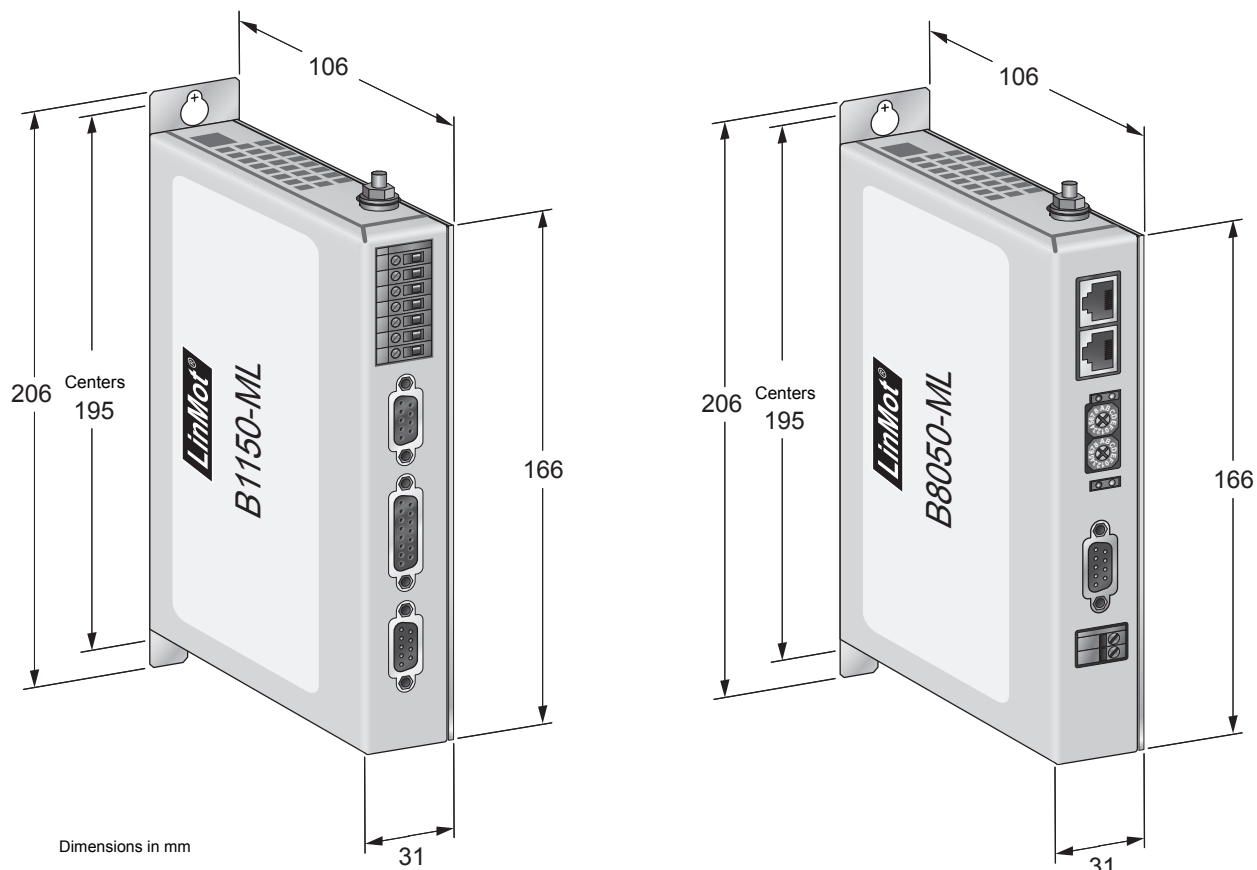

Servo Drive Series B1150/8050

Width	mm (in)	31 (1.3)
Hight	mm (in)	166 (6.6)
Hight without fixings	mm (in)	206 (8.1)
Depth	mm (in)	106 (4.2)
Weight	g (lb)	700 (1.6)
IP Protection class	IP	20
Storage temperature	°C	-25...40
Transport temperature	°C	-25...70
Operating temperature	°C	0...40 at rated date 40...50 with power derating
Max. case temperature	°C	70
Max. power dissipation	W	30
Min. distance between drives	mm (in)	20 (0.8) left/right 50 (2) top/bottom

Item	Description	Part Number
B1150-ML	MC-Link Drive (72V/8A)	0150-1796
B1150-ML-HC	MC-Link Drive (72V/15A)	0150-1797
B1150-ML-XC	MC-Link Drive (72V/25A)	0150-1798
B8050-ML-EC	8-Axes Bus Module EtherCAT	0150-1878
B8050-ML-IP	8-Axes Bus Module Ethernet IP	0150-1879
B8050-ML-PL	8-Axes Bus Module Powerlink	0150-1877
B8050-ML-PN	8-Axes Bus Module Profinet	0150-1880
B8050-ML-SC	8-Axes Bus Module Sercos III	0150-1881

Switched-Mode Power Supplies

115VAC / 230VAC



Item	Description	Part Number
S01-72/500	Switched-Mode Power Supply 72V/500W	0150-1874
S01-72/1000	Switched-Mode Power Supply 72V/1000W	0150-1872

Transformer Supply T01

3x230/280/400/480VAC



Item	Description	Part Number
T01-72/420...1500-Multi	Transformer Supply 3x230/280/400/480VAC, 50/60Hz, 420...1500W	see page 532

Control Box B01-E1100



Item	Description	Part Number
B01-E1100	Control Box for E1100 (incl. cable and connectors)	0150-1970
B01-B1150	Control Box for B1150 (incl. cable and connectors)	0150-2110

Connector Cable and USB-Converter



Item	Description	Part Number
RS232 PC config. cabel 2m	for E100/E1001/E1100/B1150	0150-3307
USB-Serial Converter	USB to 9-pin Serial Converter	0150-3110
RJ45/RJ45-0.2-ML1	MC-Link Cable, 0.2m	0150-3308

Option: External High Resolution Encoder



Item	Description	Part Number
MS01-1/D	Linear Encoder 1um, A/B (for 1mm magnetic band)	0150-1840
MB01-1000	Magnetic Band 1mm pitch, per cm	0150-1963

LinMot®

Linear Motor Series P10-70



Peak force up to 2'500N



Velocity up to 5m/s



Acceleration up to 100g



Free positioning



Long life: Linear direct drive

The linear motor technology for industrial applications

High Force Linear Motor System

With the Linear Motor Family P10-70 LinMot extends the product range with bigger and more powerful actuators for 3x400VAC for forces up to 2'500N. Five different motor sizes from 500N to 2'500N will cover a wide range of high power applications with heavy loads. The motors are controlled by the new Series E1400 Servo Drives with Field bus and industrial Ethernet Interfaces. The E1400 Drives are directly supplied from the AC mains with a 3x340...480VAC input range.

LinMot industrial linear motors are design elements that offer significant advantages over typical elements such as pneumatic cylinders, servomotors with spindles and belts, or mechanical solutions such as cam, discs or crank designs. LinMot industrial linear motors are new design elements that enable innovative solutions for new functional units, modules, or entire machines that were previously impractical using traditional elements. The high level of integration (bearings and position sensors are integrated in the motor) and the ability to integrate LinMot systems into a wide range of control systems shorten the design-in time.



Since the form factor of LinMot linear motors is similar to that of pneumatic cylinders, they are often used as replacements for pneumatic cylinders. This is especially the case when more than two positions are required, if the positions need to be changed via software, or if the dynamics or lifespan of the pneumatic cylinder is not sufficient.

The new LinMot Linear Motors size P10-70 will open the LinMot technology for new applications with higher forces and higher loads

Linear Motors Series P10-70

LinMot linear motors employ a direct electromagnetic principle. Electromagnetic force provides direct linear movement without the use of cams, gears, belts, or other mechanical devices. The motor consists of only two parts: the slider and the stator. The slider is a precision assembly that consists of a stainless steel tube, which is filled with neodymium magnets, that has threaded attachment holes on each end. The stator, consisting of coils, the bearing for the slider, position sensors and a microprocessor, is designed for use in harsh industrial environments.

The internal position sensors measure and monitor the current position of the linear motor, both at rest and in motion.

Deviations from desired position are captured immediately and reported to the control system. This guaran-

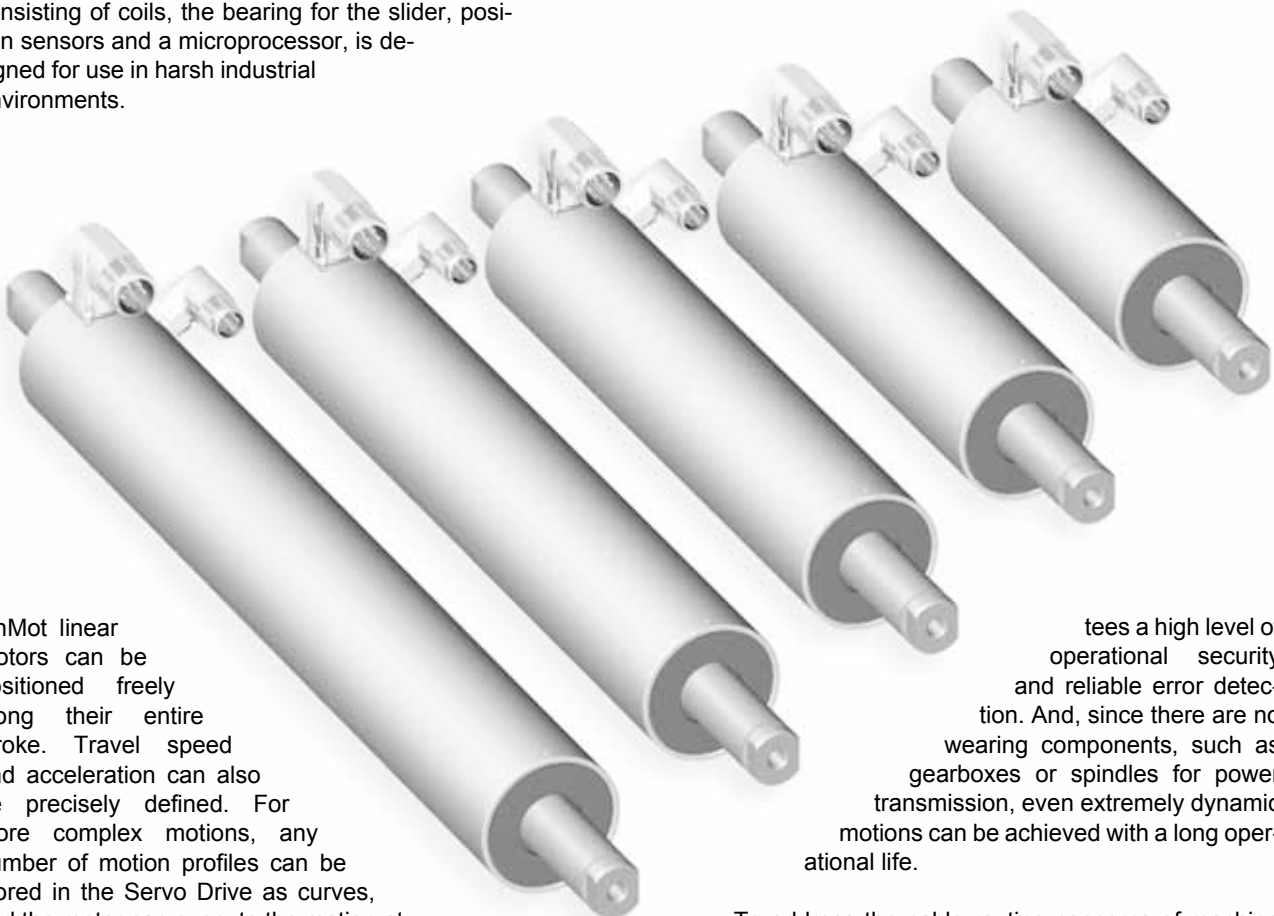

LinMot linear motors can be positioned freely along their entire stroke. Travel speed and acceleration can also be precisely defined. For more complex motions, any number of motion profiles can be stored in the Servo Drive as curves, and the motor can execute the motion at the desired speed. The motion of the linear motor can also be synchronized with another rotary or linear motion.

Extremely dynamic motions can be achieved with industrial linear motors. Velocities over 5m/s and accelerations of well over 100g provide very short positioning times and high cycle rates. With the elimination of components afflicted by mechanical play, such as gearboxes or gear racks, linear motors can be positioned as precisely as desired, consistent with the resolution of the measurement system.

tees a high level of operational security and reliable error detection. And, since there are no wearing components, such as gearboxes or spindles for power transmission, even extremely dynamic motions can be achieved with a long operational life.

To address the cable routing concerns of machine designers, LinMot provides motors with two rotatable IP67 connectors for signal and power mounted right on the motor.

The 3x400VAC motors are available in 5 different sizes with peak forces of from 500 to 2'500 N and strokes up to 1770 mm. In addition, the modular design of LinMot motors allows custom designs even in moderate quantities.

Motor Specification

		P10-70x80	P10-70x160	P10-70x240	P10-70x320	P10-70x400
Maximum stroke	mm	1770	1690	1610	1530	1450
Peak force	N	557	1104	1617	2162	2703
Continuous stall force ¹	N	65	126	183	250	312
Continuous stall force ²	N	99	191	279	381	479
Continuous stall force ³	N	174	337	488	673	862
Max. velocity	m/s	7.4	6.8	6.5	5.9	4.7
Max. acceleration	m/s ²	409	603	882	939	975

Electrical Specification

		P10-70x80	P10-70x160	P10-70x240	P10-70x320	P10-70x400
Nominal DC-Link Voltage	Vdc	560	560	560	560	560
Maximum DC-Link Voltage	Vdc	750	750	750	750	750
Peak current	A _{pk}	11	20	28	34	34
Peak current	A _{rms}	7.8	14.1	19.8	24.0	24.0
Continuous stall Current ¹	A _{rms}	0.9	1.7	2.3	2.9	2.9
Continuous stall Current ²	A _{rms}	1.4	2.5	3.5	4.4	4.4
Continuous stall Current ³	A _{rms}	2.5	4.5	6.2	7.8	8.0
Force constant	N/A _{rms}	71.6	78.1	81.6	89.9	112.4
Back EMF constant (ph-ph)	V _{pk} /(m/s)	60.5	66	69	76	95
Resistance @ 25°C (ph-ph)	Ohm	12.8	8.1	6.2	5.4	6.8
Resistance @ 100°C (ph-ph)	Ohm	16.54	10.47	8.01	6.98	8.79
Inductance (ph-ph)	mH	26	15.6	11.6	10.2	12.8

Thermal Specification

		P10-70x80	P10-70x160	P10-70x240	P10-70x320	P10-70x400
Max. winding temp.	°C	90	90	90	90	90
Max. Duration with peak current	s	4.2	4.1	4.2	4.6	4.6
Max. power dissipation ^{1/2/3}	W	21/49/153	42/98/306	63/146/447	85/196/611	106/250/809
Thermal resistance ^{1/2/3}	°C/W	2.6/1.12/0.36	1.3/0.56/0.18	0.87/0.377/0.123	0.65/0.28/0.09	0.52/0.22/0.068
Thermal time constant ^{1/2/3}	s	4200/1000/100	4200/1000/100	4200/1000/100	4200/1000/100	4200/1000/100
Thermal winding capacity ¹	°C/J	50	101	157	220	277

Mechanical Specification

		P10-70x80	P10-70x160	P10-70x240	P10-70x320	P10-70x400
Stator length	mm	180	260	340	420	500
Stator diameter	mm	70	70	70	70	70
Stator mass	kg	2.85	4.2	5.55	6.9	8.25
Slider length (min/max)	mm	290/1990	390/1990	390/1990	490/1990	590/1990
Slider diameter	mm	28	28	28	28	28
Slider mass	kg/m	4.7	4.7	4.7	4.7	4.7
Magnetic period (el. cycle)	mm	40	40	40	40	40

1) Passive Cooling @ 25°C

2) Fan Cooling @ 25°C

3) Liquid Cooling @ 25°C

Power Connector

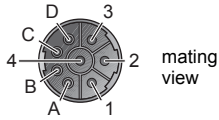

Connector:
Intercontec
SpeedTec Series 923
BEDC 110 NN00 0001 01 000
Cable:
screened motor cable
wire diameter = 1.5mm²

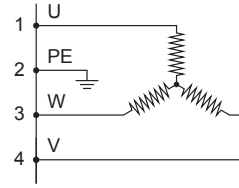
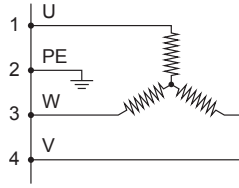

	PS10-70x...	PS10-70x...-D01 and -D02
1	Phase U	Phase U
2	Protective Earth	Protective Earth
3	Phase W	Phase W
4	Phase V	Phase V
A	n.c.	n.c.
B	n.c.	n.c.
C	n.c.	n.c.
D	n.c.	n.c.

Encoder Connector

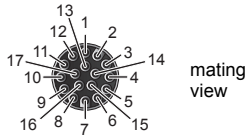

Connector:
Intercontec
SpeedTec, Series 617
AEDA 874 NN00 0005 1A 000

Cable:
screened twisted pair
encoder cable,
wire diameter = 0.5mm²

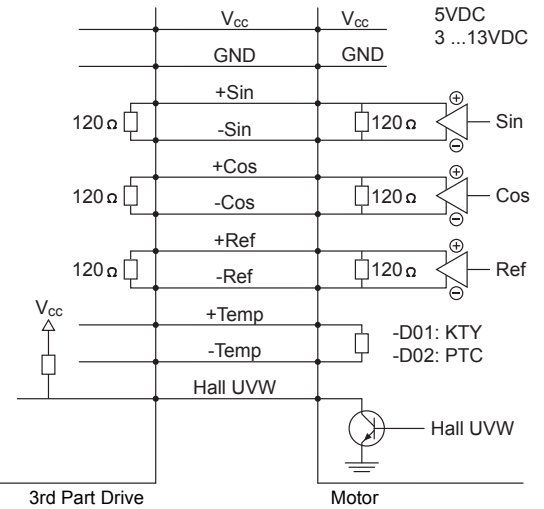
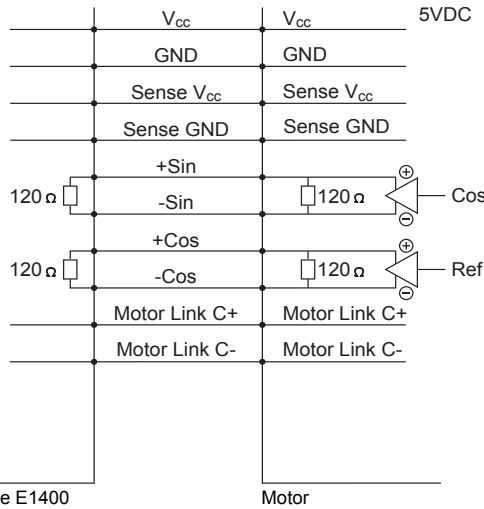

	PS10-70x...	PS10-70x...-D01 and -D02
1	+5VDC	3...13VDC
2	GND	GND
3	Sense +5V	Sense Vcc (optional)
4	Sense GND	Sense GND (optional)
5	Motor Link C+	n.c.
6	Motor Link C-	n.c.
7	Sin+	Sin+
8	Sin-	Sin-
9	Cos+	Cos+
10	Cos-	Cos-
11	n.c.	Ref.+
12	n.c.	Ref.-
13	n.c.	Hall U
14	n.c.	Hall V
15	n.c.	Hall W
16	n.c.	Temp+ (-D01: KTY984/130 -D02: PTC)
17	n.c.	Temp- (-D01: KTY984/130 -D02: PTC)

PS10-70x80

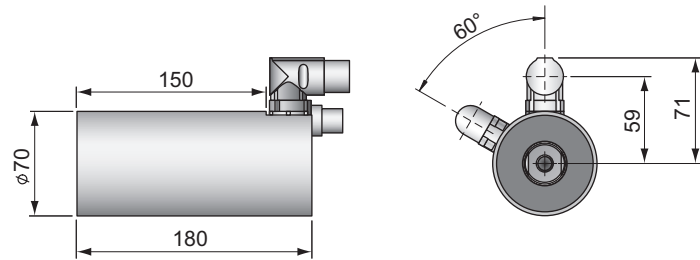

PS10-70x160

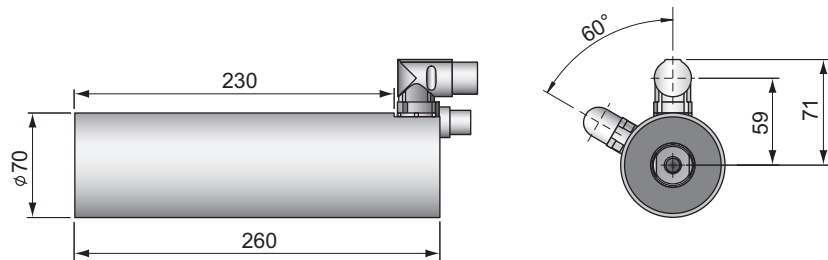

PS10-70x240

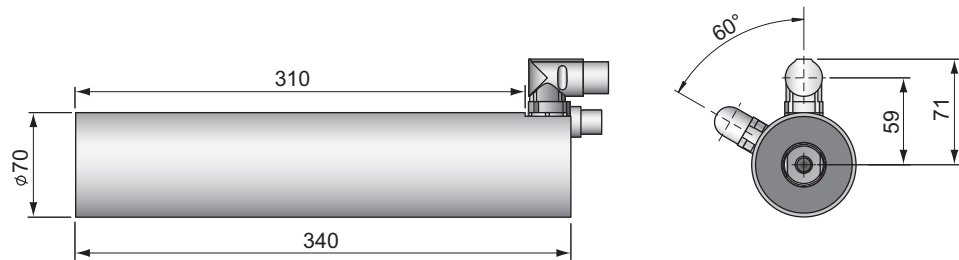

PS10-70x320

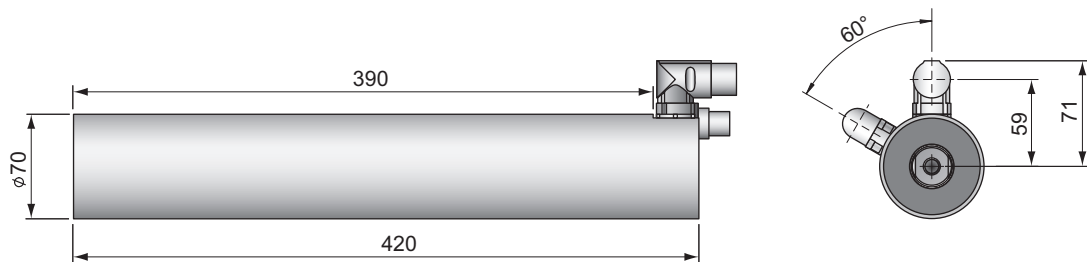

PS10-70x400

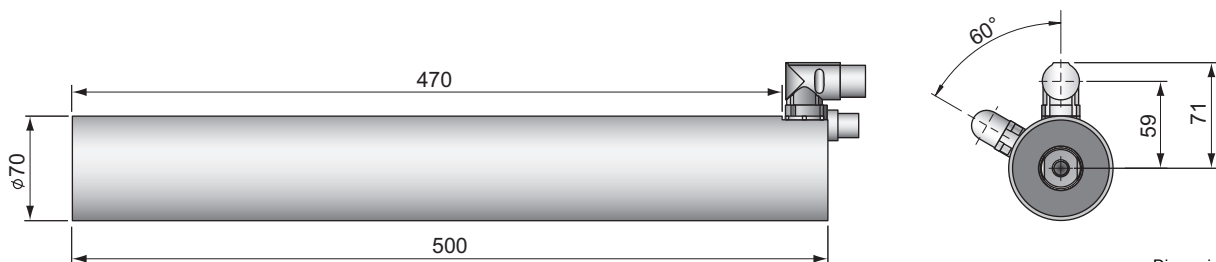

Dimensions in mm

Strokes

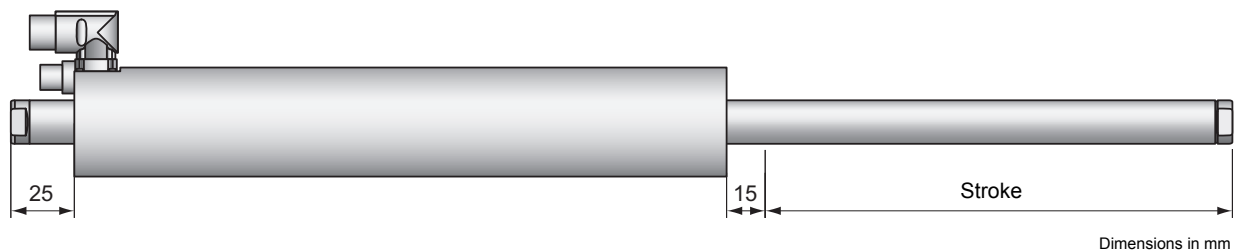

Stator	PS10-70x80	PS10-70x160	PS10-70x240	PS10-70x320	PS10-70x400
Slider	Stroke in mm				
PL10-28x290/240	70				
PL10-28x390/340	170	90	10		
PL10-28x490/440	270	190	110	30	
PL10-28x590/540	370	290	210	130	50
PL10-28x690/640	470	390	310	230	150
PL10-28x790/740	570	490	410	330	250
PL10-28x890/840	670	590	510	430	350
PL10-28x990/940	770	690	610	530	450
PL10-28x1190/1140	970	890	810	730	650
PL10-28x1390/1340	1170	1090	1010	930	850
PL10-28x1590/1540	1370	1290	1210	1130	1050
PL10-28x1790/1740	1570	1490	1410	1330	1250
PL10-28x1990/1940	1770	1690	1610	1530	1450

Ordering information

Item	Description	Part Number
Stator Series PS10-70		
PS10-70x80U-BL-QJ	Stator 3x400VAC, LinMot Encoder	0150-1291
PS10-70x160U-BL-QJ	Stator 3x400VAC, LinMot Encoder	0150-1292
PS10-70x240U-BL-QJ	Stator 3x400VAC, LinMot Encoder	0150-1293
PS10-70x320U-BL-QJ	Stator 3x400VAC, LinMot Encoder	0150-1284
PS10-70x400U-BL-QJ	Stator 3x400VAC, LinMot Encoder	0150-1294
Stator Series PS10-70-D01 and -D02		
PS10-70x80U-BL-QJ-D01	Stator 3x400VAC, SinCos Encoder 1Vpp, KTY	0150-2282
PS10-70x160U-BL-QJ-D01	Stator 3x400VAC, SinCos Encoder 1Vpp, KTY	0150-2283
PS10-70x240U-BL-QJ-D01	Stator 3x400VAC, SinCos Encoder 1Vpp, KTY	0150-2284
PS10-70x320U-BL-QJ-D01	Stator 3x400VAC, SinCos Encoder 1Vpp, KTY	0150-2285
PS10-70x400U-BL-QJ-D01	Stator 3x400VAC, SinCos Encoder 1Vpp, KTY	0150-2286
PS10-70x80U-BL-QJ-D02	Stator 3x400VAC, SinCos Encoder 1Vpp, PTC	0150-2360
PS10-70x160U-BL-QJ-D02	Stator 3x400VAC, SinCos Encoder 1Vpp, PTC	0150-2361
PS10-70x240U-BL-QJ-D02	Stator 3x400VAC, SinCos Encoder 1Vpp, PTC	0150-2362
PS10-70x320U-BL-QJ-D02	Stator 3x400VAC, SinCos Encoder 1Vpp, PTC	0150-2343
PS10-70x400U-BL-QJ-D02	Stator 3x400VAC, SinCos Encoder 1Vpp, PTC	0150-2363
Slider Series PL10-28		
PL10-28x290/240	Slider for P10-70 "standard"	0150-2193
PL10-28x390/340	Slider for P10-70 "standard"	0150-2194
PL10-28x490/440	Slider for P10-70 "standard"	0150-2195
PL10-28x590/540	Slider for P10-70 "standard"	0150-2196
PL10-28x690/640	Slider for P10-70 "standard"	0150-2197
PL10-28x790/740	Slider for P10-70 "standard"	0150-2198
PL10-28x890/840	Slider for P10-70 "standard"	0150-2199
PL10-28x990/940	Slider for P10-70 "standard"	0150-2203
PL10-28x1190/1140	Slider for P10-70 "standard"	0150-2204
PL10-28x1390/1340	Slider for P10-70 "standard"	0150-2205
PL10-28x1590/1540	Slider for P10-70 "standard"	0150-2206
PL10-28x1790/1740	Slider for P10-70 "standard"	0150-2207
PL10-28x1990/1940	Slider for P10-70 "standard"	0150-2208

Flanges and ventilator



Item	Description	Part Number
Flanges PF10-70		
PF10-70x110	Flange for PS10-70x80	0150-2272
PF10-70x190	Flange for PS10-70x160	0150-2273
PF10-70x270	Flange for PS10-70x240	0150-2274
PF10-70x350	Flange for PS10-70x320	0150-2275
PF10-70x430	Flange for PS10-70x400	0150-2276
PF10-70x110-FC	Flange for PS10-70x80 fluid cooling	0150-2291
PF10-70x190-FC	Flange for PS10-70x160 fluid cooling	0150-2292
PF10-70x270-FC	Flange for PS10-70x240 fluid cooling	0150-2293
PF10-70x350-FC	Flange for PS10-70x320 fluid cooling	0150-2294
PF10-70x430-FC	Flange for PS10-70x400 fluid cooling	0150-2295
Ventilator		
HV01-37/48	Ventilatorkit for H01-37/48 & PF02-37/48	0150-5051

Cable



Item	Description	Part Number
Sensor Cable KSS05		
KSS05-02/08-D15/J-3	High Flex cable Sensor D15/J, 3m	0150-2263
KSS05-02/08-D15/J-5	High Flex cable Sensor D15/J, 5m	0150-2262
KSS05-02/08-D15/J-8	High Flex cable Sensor D15/J, 8m	0150-2264
KSS05-02/08-D15/J-12	High Flex cable Sensor D15/J, 12m	0150-2265
KSS05-02/08-D15/J-L	Special cable KSS05-02/08-D15/J	0150-3389
Power Cable KPS15		
KPS15-04-L/Q-3	High Flex cable Power L/Q, 3m	0150-2266
KPS15-04-L/Q-5	High Flex cable Power L/Q, 5m	0150-2261
KPS15-04-L/Q-8	High Flex cable Power L/Q, 8m	0150-2267
KPS15-04-L/Q-12	High Flex cable Power L/Q, 12m	0150-2268
KPS15-04-L/Q-L	Special cable KPS15-04-L/Q	0150-3388

Servo Drive Series E1400



Servo Drive Series E1400

Series E1400 Servo Drives are modular axis drives, with 32-bit position resolution and an integrated power stage 3x400VAC, for linear motors and rotary motors.

The drives are suitable for simplest, standard, and high-end positioning tasks, across the entire force range of the LinMot product range.



Connection to Machine Drive

The Series E1400 Servo Drives can be actuated by machine controls from any manufacturer or brand, via digital inputs and outputs, RS232 or RS485 serial interface, CanBus CANopen and DeviceNet interfaces, Profibus DP, or industrial ETHERNET.

Process and Safety Interfaces

Fast process interfaces for direct processing of sensor signals are available as freely programmable analog and digital inputs, a fast trigger input, and a capture input.

The safety Interface on Servo Drive with fieldbus interfaces or industrial ETHERNET allows safe stop of the drives via control signals, per EN 954-1, without interrupting the power supply.

Logic and Power Supply

The Servo Drives have two separate power supply inputs for the logic and power elements.

In an E-stop and safe stop of the drive, only the power element supply is cut off from the drive. The logic supply and the drive continue to run.

This has the advantage that the drive and linear motor do not need to be reinitialized when the machine is restarted, since all process data, including the current position of the linear motor, are still up to date.

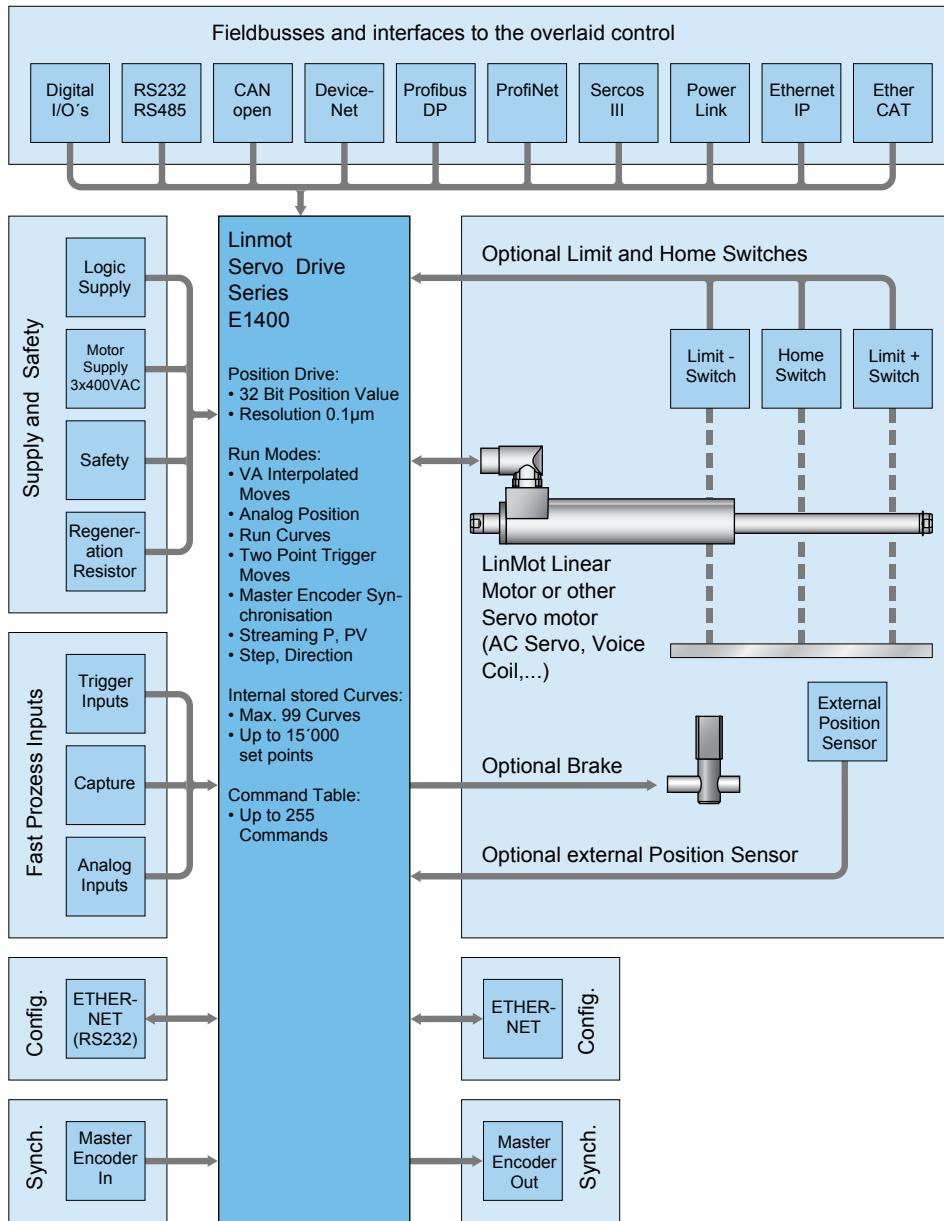

System Integration

Flexible hardware enables control of any 1/2/3-phase motors. Thus, low-power rotary servomotors, such as brushless DC motors, can be integrated in the same controls concept.

Additionally, the drives can be equipped with optional peripherals, such as reference and end stop switches, high-precision external position sensors, or a mechanical holding brake.

Series E1400 Servo Drives have analog and digital inputs and outputs, serial interfaces, fieldbuses, and ETHERNET connections. The user is therefore not dependent on the selection of the overlaid drive. An appropriate interface is available, with associated protocols, for any PLC or IPC solution.

With flexibility and a compact form factor, LinMot Series E1400 Servo Drives provide a complete solution for a flexible drive concept in single and multiple axis applications, with linear motors and other actuators.

Technology Functions

Technology functions are functional blocks that provide a complete solution for standard applications and frequently encountered, customer-specific problems. Technology functions can, for example, handle the complete sequence for winding textile yarns or glass fiber cables, or high-precision joining processes with force control can be implemented directly in the drive.

Master Encoder

For synchronization to a mechanical master shaft, or a rotating main drive, the Axis (linear motors and rotary motors) can be coupled to an electronic main shaft via the Master Encoder Interface.

The encoder signal from the main shaft can be passed through by the Master Encoder Interface, so that any number of linear motors can be synchronized to the main shaft.

Motor Interfaces

E1400 Servo Drives provide all necessary interfaces to operate linear or rotary motors with optional external peripherals, such as end position and reference switches, a mechanical brake, or a high-resolution external position sensor.

Configuration

Parameterization and configuration of the Servo Drive is done via the Ethernet interface on the front side for simultaneous configuration of several drives.

LinMot Talk user-friendly PC software is available for configuration. In addition to on-line documentation, LinMot Talk provides extensive debugging tools, such as an oscilloscope and an error inspector, for simple and rapid start-up of the Axis.

Fieldbus and ETHERNET drives can also be configured directly by the overlaid control.

Interpolated Moves

Stroke [mm]

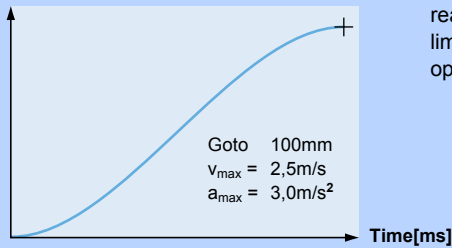

For direct position targets, using absolute or relative positioning, the desired position is reached using acceleration and velocity-limited motion profiles or jerk optimized profiles (jerk limited and Bestehorn). Positioning commands can be invoked via the serial interfaces, CAN-open, DeviceNet, Profibus, Ethernet or a trigger input.

Stroke range:	±100m
Position Resolution:	0.1µm (32Bit)
Velocity Resolution:	1.0µm/s (32Bit)
Velocity Resolution:	10.0µm/s ² (32Bit)

Time Curves

Stroke [mm]

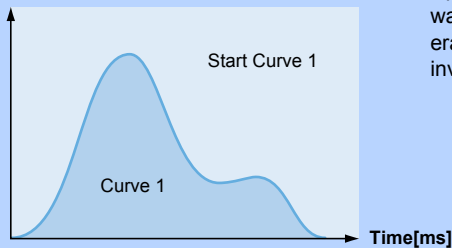

Up to 100 different time curves can be stored Series E1400 drives, with up to 16,000 individual waypoints. The motor can thus travel along time curves of any complexity, such as those generated by CAD programs and stored in the drive (Excel CSV format). The time curves can be invoked via the serial interface, fieldbuses, ETHERNET, or the trigger input.

Stroke range:	±100m
Position Resolution:	0.1µm (32Bit)
Motion profiles:	Max. 100 Time Curves
Curve points:	Max. 16'000 points

Profiled Moves

Stroke [mm]

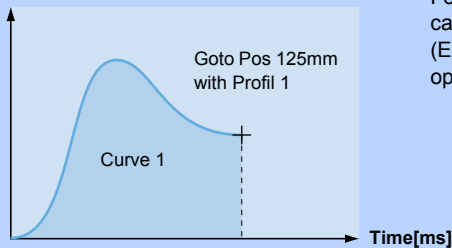

For travel to an absolute position, or shifting by a relative position, any desired motion rules can be stored besides the VA interpolator. They are stored in the drive as motion profiles (Excel CSV format). The positions can be approached, for example, with a sinusoidal motion to optimize power loss, or special reverse optimized motion profiles.

Stroke range:	±100m
Position Resolution:	0.1µm (32Bit)
Motion profiles:	Max. 100 Time Curves
Curve points:	Max. 16'000 points

Setpoint Streaming

Stroke [mm]

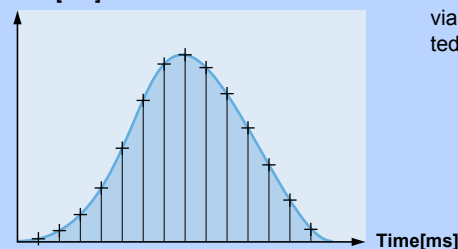

Overlaid NC drives with fieldbus or ETHERNET interfaces communicate with the Servo Drives via "Position Streaming". The position and velocity calculated in the overlaid control is transmitted to the Servo Drive cyclically. The P, PV, or PVT mode is available for this transmission.

Position Resolution:	32 Bit
Velocity Resolution:	32 Bit
Interpolator:	10 kHz
cycle times:	0.4-5ms

Easy Steps

Input 1	Pos 125mm
Input 2	Pos 250mm
Input 3	Curve 1
Input 4	Pos -30mm
Input 5	Pos +12,5mm
Input 6	Curve 2
Input 7	Pos 2mm
Input 8	Pos -12,5mm

With the Easy Steps function, up to 8 positions or independent travel commands can be stored on the drive, and addressed via 8 digital inputs or fieldbus interfaces/ETHERNET.

Digital inputs: max. 8
Interface: X4
Scanning rate: 200µsec

Command Table

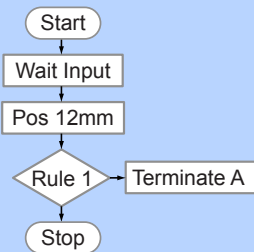

Entire motion sequences with up to 255 individual motion commands can be stored in the Command Table. This is primarily advantageous if complete motion sequences need to be executed very quickly, without dead time from the overlaid drive. In the Command Table, the programmer has access to all motion commands, internal parameters, and digital inputs and outputs.

Commands: max. 255
Cycle time: 100µsec

Master Encoder Synchronization (MT)

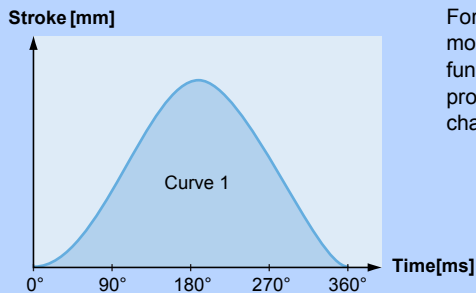

For synchronization to an external main or master shaft, the linear motor travels along the motion profiles stored in the drive, at the machine speed (machine angle 0...360°). Using this function, mechanical cam discs can be replaced with highly dynamic linear motors. The motion profiles can be freely defined, and the correct motion profile can be invoked during product changeover with no changeover time.

Motion profiles: Max. 100 curve profiles
Curve points: Max. 16'000 points
Encoder Counter: 32 Bit
Encoder Input: A/B/Z (RS422)
Max. counting frequency: Max. 4.5 MHz

Belt Synchronization

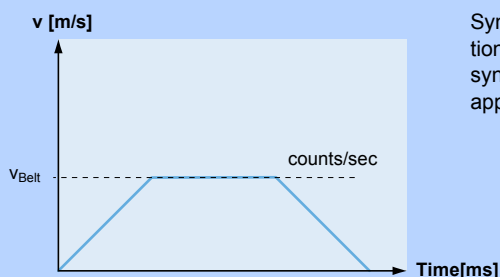

Synchronization to a belt speed can be done using the Master Encoder Interface or Step/Direction/Zero interface. Applications such as the "flying saw", synchronous loading or unloading, synchronous filling or labeling of bottles or containers on a conveyor belt, and many other applications can be implemented in this way.

Encoder Counter: 32 Bit
Encoder Input: A/B/Z (RS422), max. 5 MHz
STEP/DIR/ZERO
Max. counting frequency: Max. 4.5 MHz

Analog Position

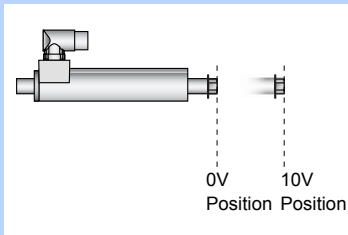

For an analog position target, the linear motor travels to a position proportional to the input voltage. The position is either scanned continuously, or only after a rising edge of the trigger signal. In order to prevent uncontrolled jumps in position, the motor travels to the positions with a programmable maximum acceleration and velocity (VA interpolator).

Inputs:	Analog Input X4 or X20
Voltage range:	0-10VDC or ±10V
Resolution:	12 Bit
Scanning rate:	>=100µsec (adjustable)

Easy Steps Parameter Scale

Maximum Force [0...10V => 0...100%]

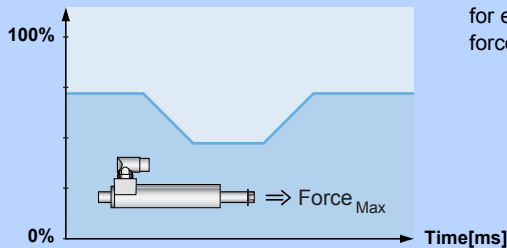

Easy Steps provide the ability to parameterize internal parameters using two analog inputs. If, for example, the maximum motor current is read at an analog input, then the maximum motor force can be provided as analog for freely programmable joining processes.

Inputs:	2 x Analog (X4.4, X4.7)
Voltage range:	0-10VDC
Resolution:	12 Bit
Resolution	200µsec

Closed Loop Force Control

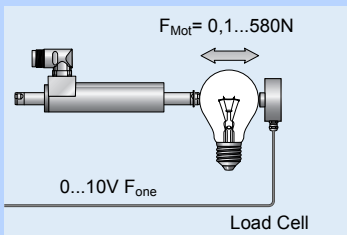

Using the force control technology function, precise joining processes can be implemented reliably and reproducibly with high-precision force control. For force control, the current motor force is measured with a load cell and controlled in the drive. Joining process or quality checks with high requirements for applied force can be implemented.

Analog Input:	0-10V or ±10V
Resolution:	12 Bit
Min. Force Resolution:	0.1N

Winding Application

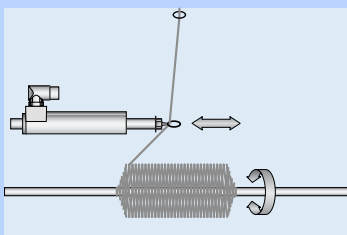

For winding textile yarns, glass fiber optics, or wires, a complete functional block is available that controls the entire sequence of a complete winding process.

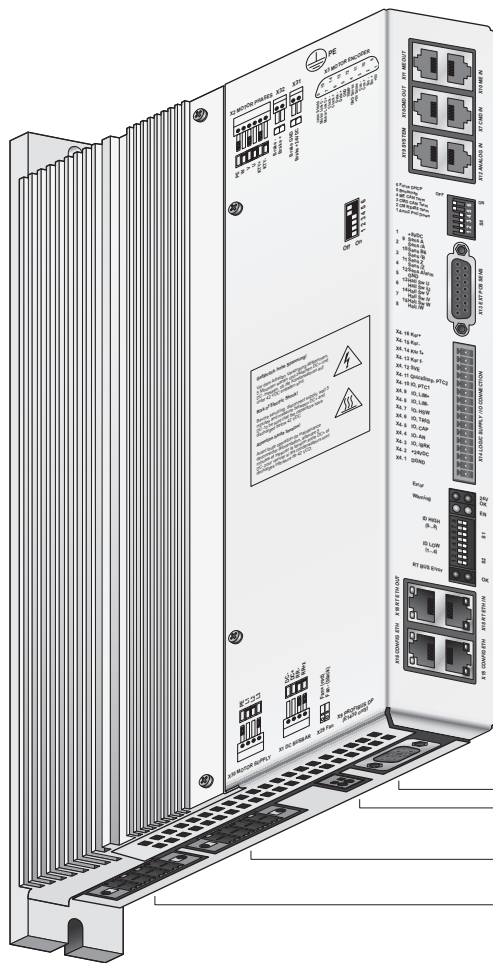

- X10: Master Encoder IN
- X11: Master Encoder OUT
- X7: CMD (RS485 / CAN)
- X8
- X19: System
- X20: Analog IN
- S5: Bus Termination
- X13: External Positionssensor
- X4: Logic Supply / IO Connection
- LED State Display
- S1-2: Adress Selectors
- LED RT Bus State Display
- X17-: RealTime ETHERNET
- X18
- X15-: ETHERNET Configuration
- X16
- X9: Profibus (only -DP)
- X29: Fan
- X1: DC Busbar / Regeneration Resistor
- X30: Motor Suply Mains

	E1400-GP-QN	E1430-DP-QN	E1450-PL-QN	E1450-EC-QN	E1450-PN-QN	E1450-IP-QN	E1450-SC-QN	E1450-SE-QN
Interfaces								
CANopen	•	•	•	•	•	•	•	•
LinRS	•	•	•	•	•	•	•	•
PROFIBUS-DP		•						
POWERLINK			•					
ETHERCAT				•				•
PROFINET					•			
ETHERNET IP						•		
SERCOS III							•	
SERCOS over EtherCAT				•			•	•
Config. ETHERNET	•	•	•	•	•	•	•	•

E1400-GP-QN
 E1430-DP-QN
 E1450-PL-QN
 E1450-EC-QN
 E1450-PN-QN
 E1450-IP-QN
 E1450-SC-QN

- ✓ Absolute & Relative Positioning
- ✓ Travel Along Time Curves
- ✓ Positioning using Motion Profiles
- ✓ Internally stored Motion Commands
- ✓ Internally stored Motion Sequences
- ✓ Master Encoder Synchronization
- ✓ Synchronization to Belt Speed
- ✓ Position Streaming
- ✓ Analog Position Target
- ✓ Analog Parameter Scaling
- ✓ Winding Function Block
- ✓ Force Control Technology Function
- ✓ Customer-Specific Functions

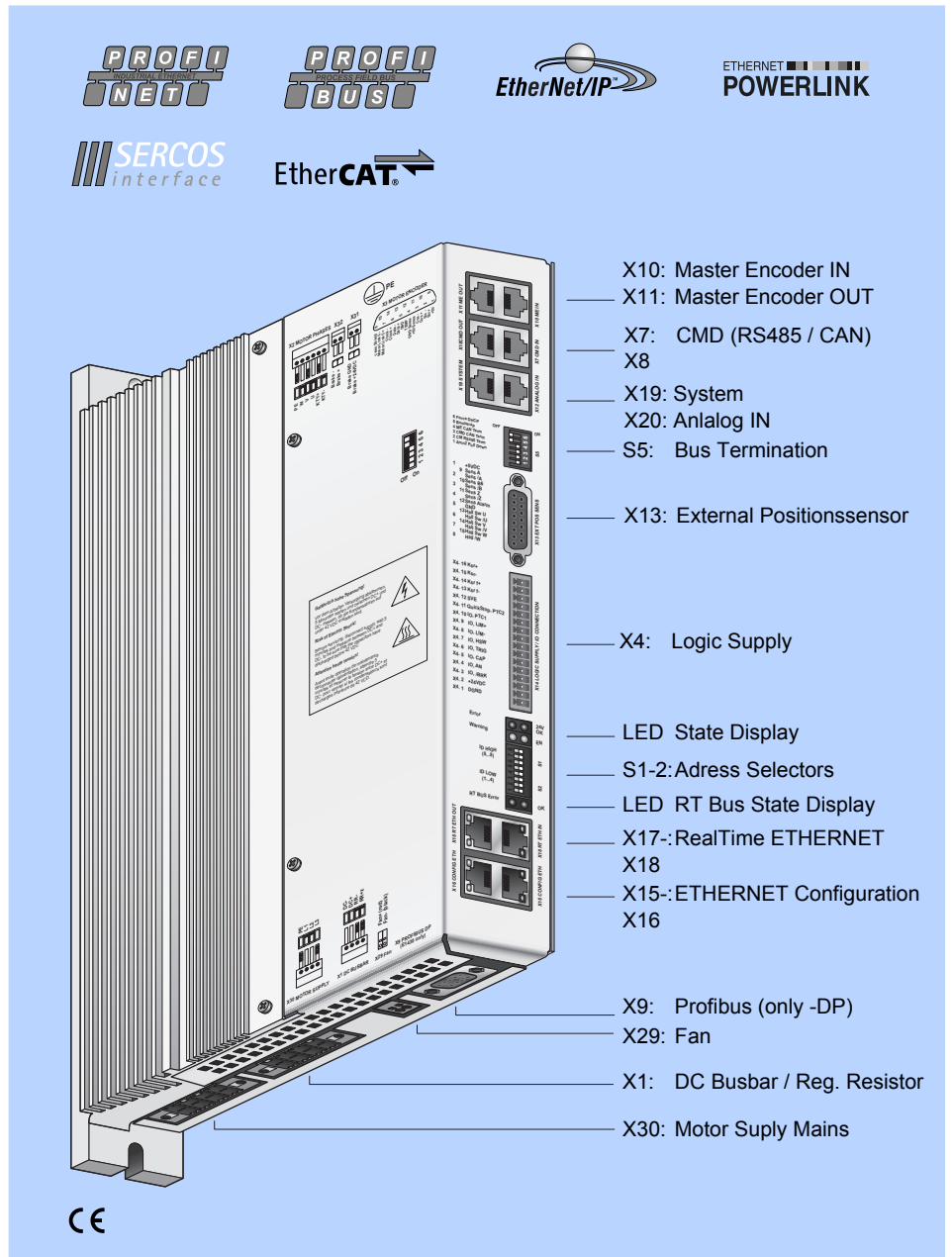

Industrial ETHERNET

Series E1400 drives allow integration of LinMot linear motors in controls concepts with industrial ETHERNET interfaces. The user can integrate Series E1400 drives regardless of the provider of the overlaid control.

LinMot drives are available with common industrial ETHERNET protocols. Since all ETHERNET drives have the same motion command interface, and the control and status word are identical, software blocks that have been implemented once can be transferred to other drives without a problem.

Technical Data

Series 1200 Servo Drives support the following industrial ETHERNET protocols:

- Profinet
- Industrial IP
- PowerLink
- EtherCat
- Sercos III

The appropriate drive is available for each protocol.

Technical Data

Type:	Realtime ETHERNET
Switch/Hub:	Integrated 2-Port Hub/Switch
Transfer rate:	10/100MBit/sec

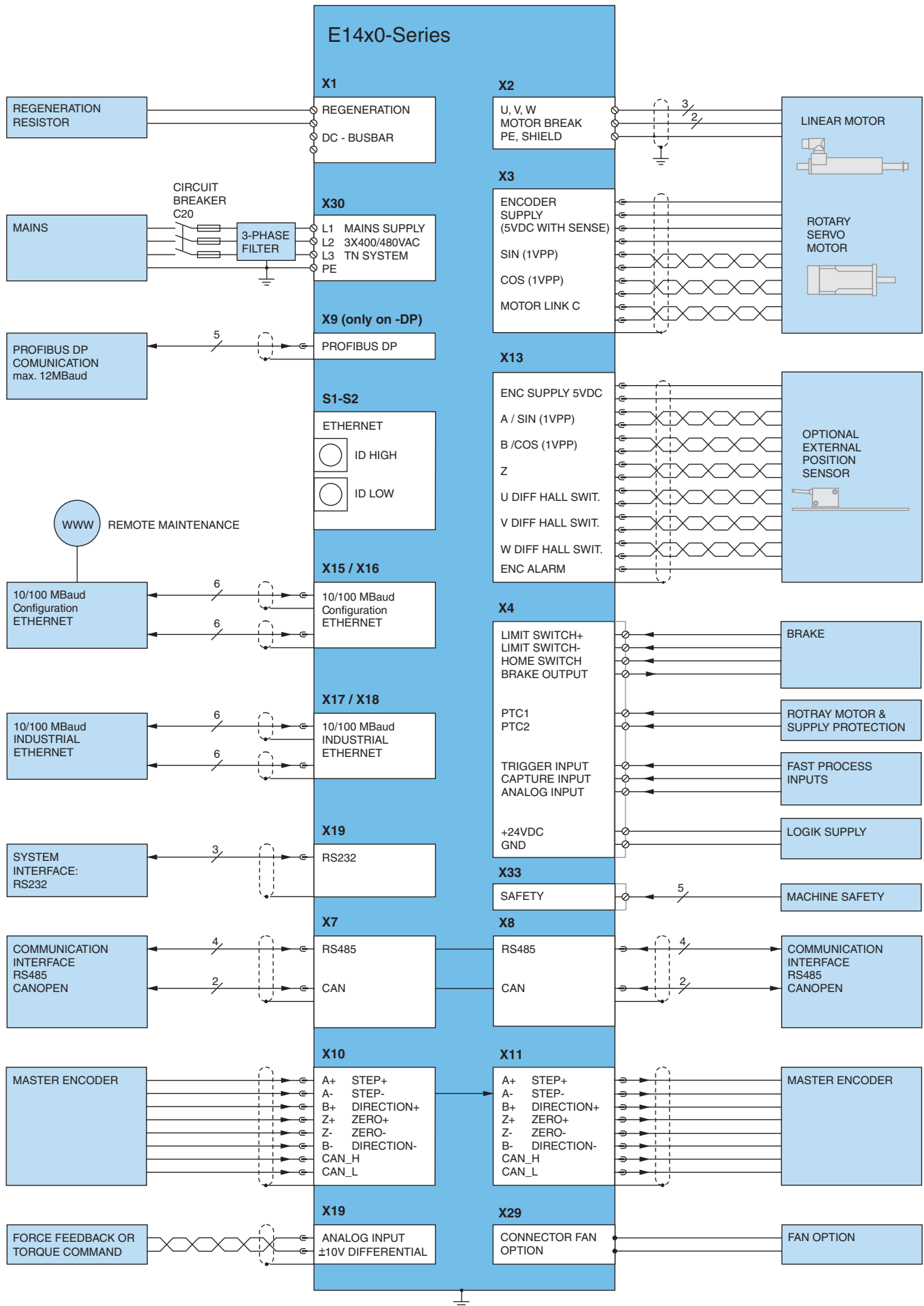

X1 DC Busbar / Regeneration Resistor

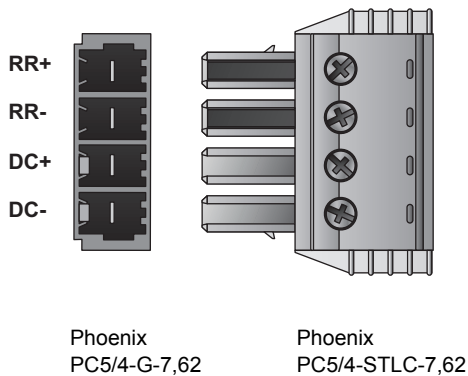

Nr.	Designation
DC+	DC busbar +
DC-	DC busbar -
RR+	Positive connection for Regeneration Resistor
RR-	Negative connection for Regeneration Resistor

Screw Terminals:

- 0.25 - 4mm² (depends on Motor current) / AWG 24-12
- Tightening torque: 0.7 - 0.8 Nm
- Use a cross-head screw driver (PH1)
- Use 60/75°C copper conductors only
- Stripping length 10mm

X30 Motor Supply Mains

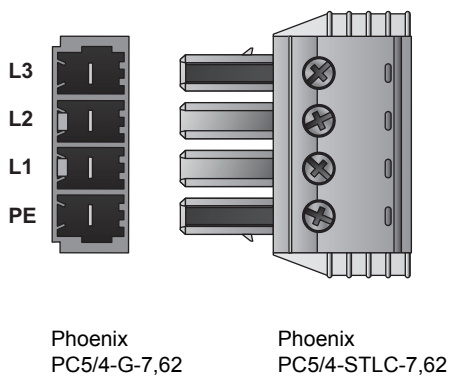

Nr.	Designation
L1	
L2	3x400 / 3x480VAC 50/60 Hz
L3	
PE	PE, Protective Earth

Screw Terminals:

- 2.5 - 4mm² (depends on Motor current) / AWG 24-12
- Tightening torque: 0.7 - 0.8 Nm
- Use a cross-head screw driver (PH1)
- Use 60/75°C copper conductors only
- Stripping length 10mm

X2 Motor Phases

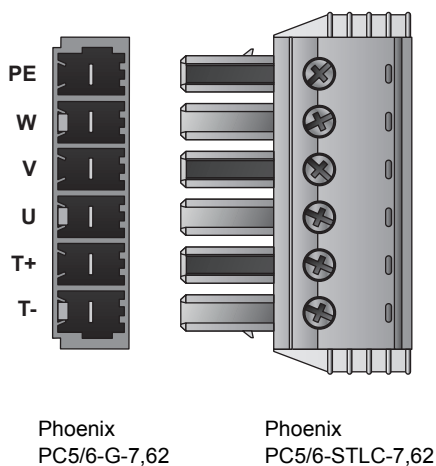

Nr.	Designation
PE	Protective Earth and Cable Shield
W	Motor Phase W
V	Motor Phase V
U	Motor Phase U
T+	Temperature Sensor positive
T-	Temperature Sensor negative

Screw Terminals:

- 0.25 - 4mm² (depends on Motor current) / AWG 24-12
- Tightening torque: 0.7 - 0.8 Nm
- Use a cross-head screw driver (PH1)
- Use 60/75°C copper conductors only
- Stripping length 10mm

X3-V2 Motor Encoder (Motor Link C / BISS)

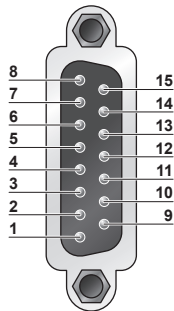

DSUB-15 (m)

Nr	Description
8	Motor Link C-
15	Motor Link C+
7	Clock-
14	Clock+
6	Data-
13	Data+
5	GND
12	Temp
4	GND Sense
11	+5V Sense
3	Cos-
10	Cos+
2	Sin-
9	Sin+
1	+5V
case	shield

Motor Link C is a high speed serial communication protocol to the motor encoder

X33: 8pin Safety Relays (only for -1S)

X33. 4/8 Ksr+
X33. 3/7 Ksr-
X33. 2/6 Ksr f+
X33. 1/5 Ksr f-



X33 STO RELAYS

Nr	Description	
4 / 8	Ksr +	Safety Relay 1 / 2 Input positive
3 / 7	Ksr -	Safety Relay 1 / 2 Input negative
2 / 6	Ksr f+	Safety Relay 1 / 2 feedback positive
1 / 5	Ksr f-	Safety Relay 1 / 2 feedback negative

X4: 11pin Logic Supply / IO Connection

X4. 11 QuickStop, PTC2
X4. 10 IO, PTC1
X4. 9 IO, LIM+
X4. 8 IO, LIM-
X4. 7 IO, HSW
X4. 6 IO, TRIG
X4. 5 IO, CAP
X4. 4 IO, AN
X4. 3 IO, /BRK
X4. 2 +24VDC
X4. 1 GND



X14 LOGIC SUPPLY / IO CONNECTION

Nr	Description	
11	Input Quickstop	Quickstop, PTC2 Input
10	I/O X4.10	Configurable IO, PTC Input
9	I/O X4.9	Configurable IO
8	I/O X4.8	Configurable IO
7	I/O X4.7	Configurable IO
6	I/O X4.6	Configurable IO, Trigger Input
5	I/O X4.5	Configurable IO
4	I/O X4.4	Configurable IO, Analog Input (configurable as high imp. Input)
3	I/O X4.3/Brk	Configurable IO, Brake Driver 1A
2	+24VDC Supply	Logic Supply 22-26 VDC
1	GND Supply	Ground

X7-X8

CMD (RS485/CAN)

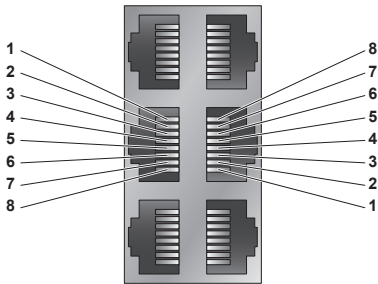

RJ-45

Nr		
1	RS485_Rx+	A
2	RS485_Rx-	B
3	RS485_Tx+	Y
4	GND	
5	GND	
6	RS485_Tx-	Z
7	CAN_H	
8	CAN_L	
Case	Shield	

- X7 internally connected to X8 (1:1 connection)
- Use twisted pair (1-2, 3-6, 4-5, 7-8) cable for wiring.
- The built in CAN and RS485 terminations can be activated by S5.2 and S5.3.

X9

Profibus DP (only available on E1430-DP-QN)

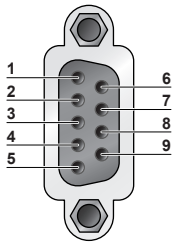

DSUB-9

Nr		
1	-	
2	-	
3	RxD/TxD-P	
4	CNTR-P	
5	GND	(galvanically separated)
6	+5V	(galvanically separated)
7	-	
8	RxD/TxD-N	
9	-	
Case	Shield	

Max. Baud rate: 12 Mbaud

X10-X11

Master Encoder IN (X10) / Master Encoder OUT (X11)

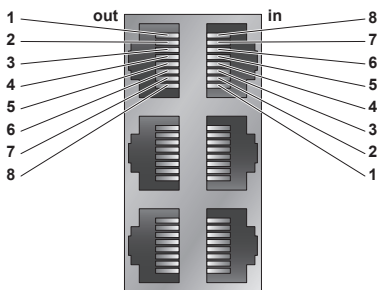

RJ-45

Nr	Incremental	Step/Direction	EIA/TIA 568A colors
1	A+	Step+	Green/White
2	A-	Step-	Green
3	B+	Direction+	Orange/White
4	Z+	Zero+	Blue
5	Z-	Zero-	Blue/White
6	B-	Direction-	Orange
7	CAN H	CAN_H	Brown/White
8	CAN L	CAN_L	Brown
Case	Shield	Shield	

*only on E1400-GP

- All devices, which are connected to X10/X11 must be referenced to the same ground.
- CAN Termination can be turned on by S5.4
- Use twisted pair (1-2, 3-6, 4-5, 7-8) cable for wiring.
- Master Encoder Inputs: Differential RS422, max. 25 M counts/s, 40ns edge separation
- Master Encoder Outputs: Amplified RS422 differential signals from Master Encoder IN (X10)

X13

External Position Sensor Commutation

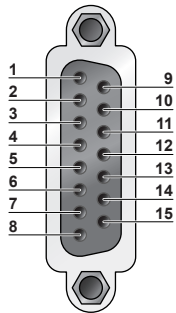

DSUB-15 (f)

Nr	Description	
1	+5V DC	
9	A+	Encoder
2	A-	Encoder
10	B+	Encoder
3	B-	Encoder
11	Z+	Encoder
4	Z-	Encoder
12	Encoder Alarm	
5	GND	
13	U+	Commutation (Hall Switch)
6	U-	Commutation (Hall Switch)
14	V+	Commutation (Hall Switch)
7	V-	Commutation (Hall Switch)
15	W+	Commutation (Hall Switch)
8	W-	Commutation (Hall Switch)
case	Shield	

Position Encoder Inputs: RS422, Max Input Frequency: 12.5MHz, 25 Mio counts/s with quadrature decoding, 40ns edge separation

Encoder Simulated Outputs:RS422, Max Output Frequency: 12.5MHz, 25 Mio counts/s with quadrature decoding, 40ns edge separation

Differential Hall Switch Inputs: RS422, Max Input Frequency: <1kHz

Enc. Alarm In: 5V / 1mA

Sensor Supply: 5VDC, max 100mA / 9VDC 100mA (SW selectable)

X15-X16

Ethernet Configuration 10/100Mbit/s

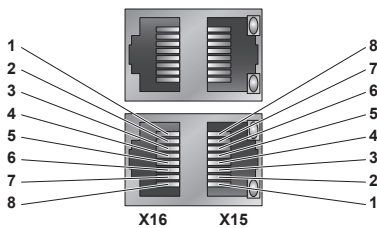

RJ-45

Nr	Description
X15	Internal 2-Port 10BASE-T and 100BASE-TX Ethernet Switch with Auto MDIX.
X16	

LED
LEDs on the lower side of the device indicate "Link/Activity" per port, the upper ones are not used.

X17-X18

RealTime Ethernet 10/100 Mbit/s

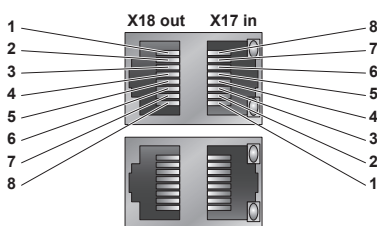

RJ-45

Nr	Description
X17	RT ETH In
X18	RT ETH Out

Specification depends on RT-Bus Type. Please refer to according documentation.

X19

System

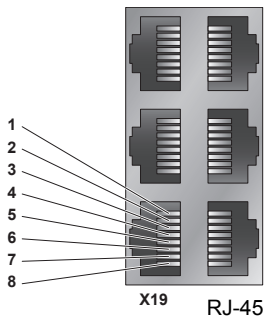

Nr	Bez.
1	Reserved, do not connect
2	Reserved, do not connect
3	RS232 RX
4	GND
5	GND
6	RS232 TX
7	Reserved, do not connect
8	Reserved, do not connect
case	Shield

Use adapter cable AC01-RJ45/Df-2.5-RS1 (Art.-No. 0150-2143) for configuration over RS232.

X20

Analog In (+-10V Differential Analog Input)

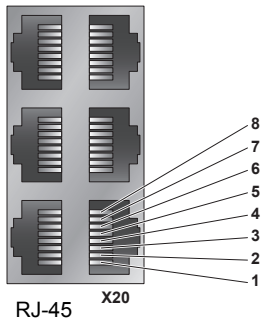

Nr	Bez.
1	n.c.
2	n.c.
3	Analog In-
4	GND
5	GND
6	Analog In+
7	n.c.
8	n.c.
case	Shield

X29

Connector for Fan Option



Nr	Bez.
-	black
+	red

Spring cage terminal block for connecting the external fan option (Art. Nr. 0150-xxxx).
 Output: 24 VDC / 0.4 A (Short circuit protected, current monitored)
 Stripping length: 8mm
 Conductor cross section: 0.2 – 1.5 mm² (AWG 24 - 16)

S5

Bus Termination / Analn2 Pull Down

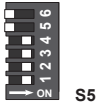

Switch	E1400
S5	Switch 6: Override Configuration Ethernet to DHCP Switch 5: Bootstrap: Must be off for normal operation Switch 4: CAN termination on ME (120R between pin 7 and 8 on X10/X11) on/off Switch 3: CAN termination on CMD (120R between pin 7 and 8 on X7/X8) on/off Switch 2: Termination resistor for RS485 on CMD (120R between pin 1 and 2 on X7/X8) on/off Switch 1: AnIn2 pull down (4k7 Pull down on X4.4). Set to ON, if X4.4 is used as digital output. Factory settings: all switches "off"

LED

State Display

Green:



24VDC Logic Supply OK

Stat A Yellow:



Motor Enabled/ Error Code Low Nibble

Stat B Yellow:



Warning / Error Code High Nibble

Red:

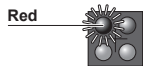

Error

LED

RT Bus LED

Green:



OK

Red:



Error

The use of these LEDs depends on the type of fieldbus which is used. Please see the corresponding manual for further information.

S1 -S2

Address Selectors

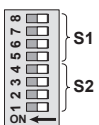

Switch	
S1 (5...8)	Bus ID High (0...F) Bit 5 is the LSB, bit 8 the MSB
S2 (1...4)	Bus ID Low (0...F) Bit 1 is the LSB, bit 4 the MSB

The use of these switches depends on the type of fieldbus which is used. Please see the corresponding manual for further information.

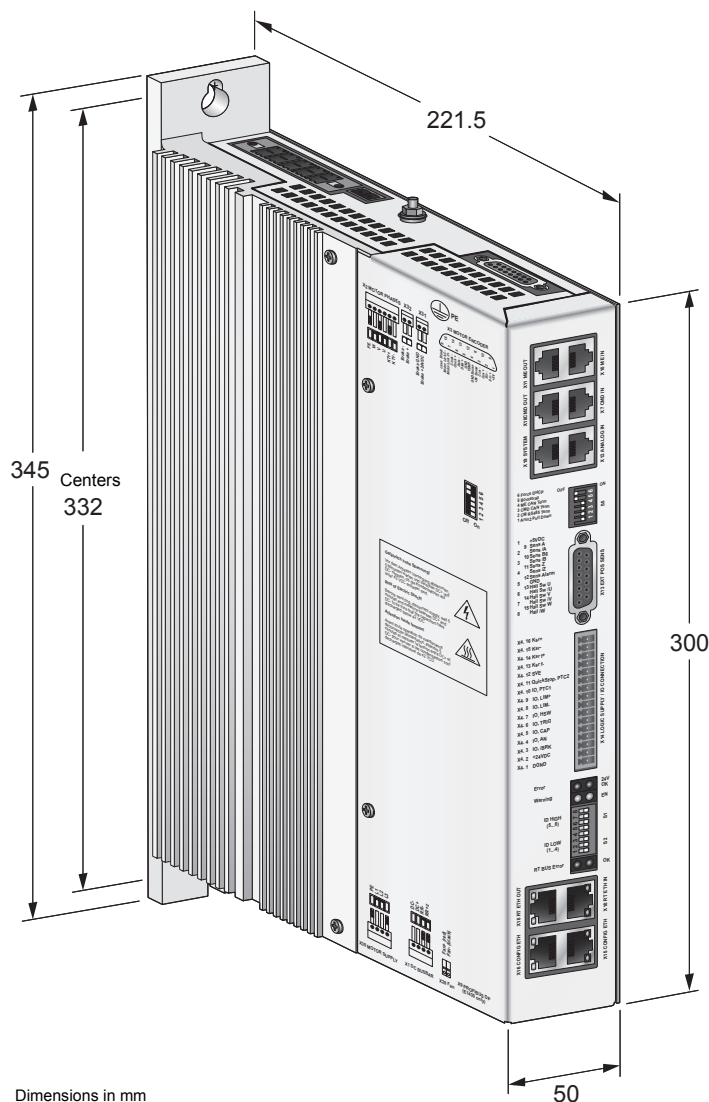

Dimensions in mm

Servo Drives Series E1400

Width	mm (in)	40 (1.6)
Height	mm (in)	270 (10.6)
Height without fixings	mm (in)	233 (9.2)
Depth	mm (in)	180 (7.1)
Weight	kg (lb)	1.5 (3.3)
IP Protection class	IP	20
Storage temperature	°C	-25...40
Transport temperature	°C	-25...70
Operating temperature	°C	0...40 at rated data / 40...50 with power derating
Max. case temperature	°C	90
Max. power dissipation	W	100
Min. distance between drives	mm (in)	20 (0.8) left/right / 50 (2) top/bottom

Item	Description	Part Number
E1400-GP-QN-0S	General Purpose Drive (3x400V/28A)	0150-1779
E1430-DP-QN-0S	Profibus DP Drive (3x400V/28A)	0150-1786
E1450-EC-QN-0S	EtherCAT Drive (3x400V/28A)	0150-1784
E1450-IP-QN-0S	Ethernet/IP Drive (3x400V/28A)	0150-1782
E1450-PL-QN-0S	POWERLINK Drive (3x400V/28A)	0150-1791
E1450-PN-QN-0S	ProfiNet Drive (3x400V/28A)	0150-1783
E1450-SC-QN-0S	Sercos III Drive (3x400V/28A)	0150-1785
E1450-SE-QN-0S	Sercos over EtherCAT Drive (3x400V/28A)	0150-1899
E1400-GP-QN-1S	General Purpose Drive (3x400V/28A), STO	0150-2351
E1430-DP-QN-1S	Profibus DP Drive (3x400V/28A), STO	0150-2352
E1450-EC-QN-1S	EtherCAT Drive (3x400V/28A), STO	0150-2353
E1450-IP-QN-1S	Ethernet/IP Drive (3x400V/28A), STO	0150-2354
E1450-PL-QN-1S	POWERLINK Drive (3x400V/28A), STO	0150-2355
E1450-PN-QN-1S	ProfiNet Drive (3x400V/28A), STO	0150-2356
E1450-SC-QN-1S	Sercos III Drive (3x400V/28A), STO	0150-2357
E1450-SE-QN-1S	Sercos over EtherCAT Drive (3x400V/28A), STO	0150-2358
EV01-E1400	Ventilator kit for Servo Drives Series E1400	0150-5055
RR01-69/100	Regeneration Resistor 100W for E1400	0150-3373

MagSpring®

Magnetic Spring



MagSprings, unlike mechanical springs, deliver a constant force over their entire working range



MagSpring, consists of only two components: a stator and a slider



MagSprings are totally passive. Their operation is based entirely on a unique application of permanent magnets - no electricity at all.

Copyright Spaceimage by NASA



MagSpring M01-20

336

MagSpring M01-37

338

MagSpring Accessories

340

MagSpring

MagSpring products can best be described as "magnetic springs." The term "spring", however, is to be understood to mean that MagSpring components generate a constant force over their entire working range, while the characteristic curve for a typical mechanical spring shows an increase in force with increasing displacement. The generation of force that is independent of the stroke makes MagSprings preferable for balancing weight forces in vertical drive applications.

Mode of Operation

The mode of operation is based on the attractive force of permanent magnets. Accordingly, no energy source (electricity, compressed air, etc.) is needed, so that safety-related applications can also be addressed. The special design of the flow-guiding components and the magnets translates the strongly non-linear relationship between force and displacement in magnet-iron arrangements into a constant force curve. Depending on the strength class of the MagSpring, the permanent magnets are either in the stator, in the slider, or in both components. The slider is guided by an integrated plain bearing, so that MagSprings can be used comparably to gas pressure springs in a design.



Weight Load Compensation

Linear motors and other direct drives must provide a constant force in vertical orientations, in order to oppose the weight load.

Using a MagSpring installed in parallel with the linear motor, this weight load can be passively balanced. The linear motor is then only used for the actual positioning operation and dynamic forces, and can therefore be correspondingly smaller in design.

Application of Constant Force

Thanks to the constant force-displacement curve, many other applications are possible, such as the generation of a constant



press force, regardless of position; application of a constant holding force across a large stroke range; or single-sided force support in drive applications.

The effective force is in the range of +/- 10% of the nominal force, due to material and manufacturing tolerances.

Holding Function (Power Off)

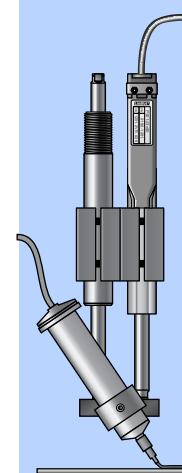

Since MagSprings are purely passive elements, a defined function or position of a device can be ensured in a power-off condition. For example, a gripper or press head on a vertical mount can be held up, or a slider can be pushed in or pulled out with a constant force.

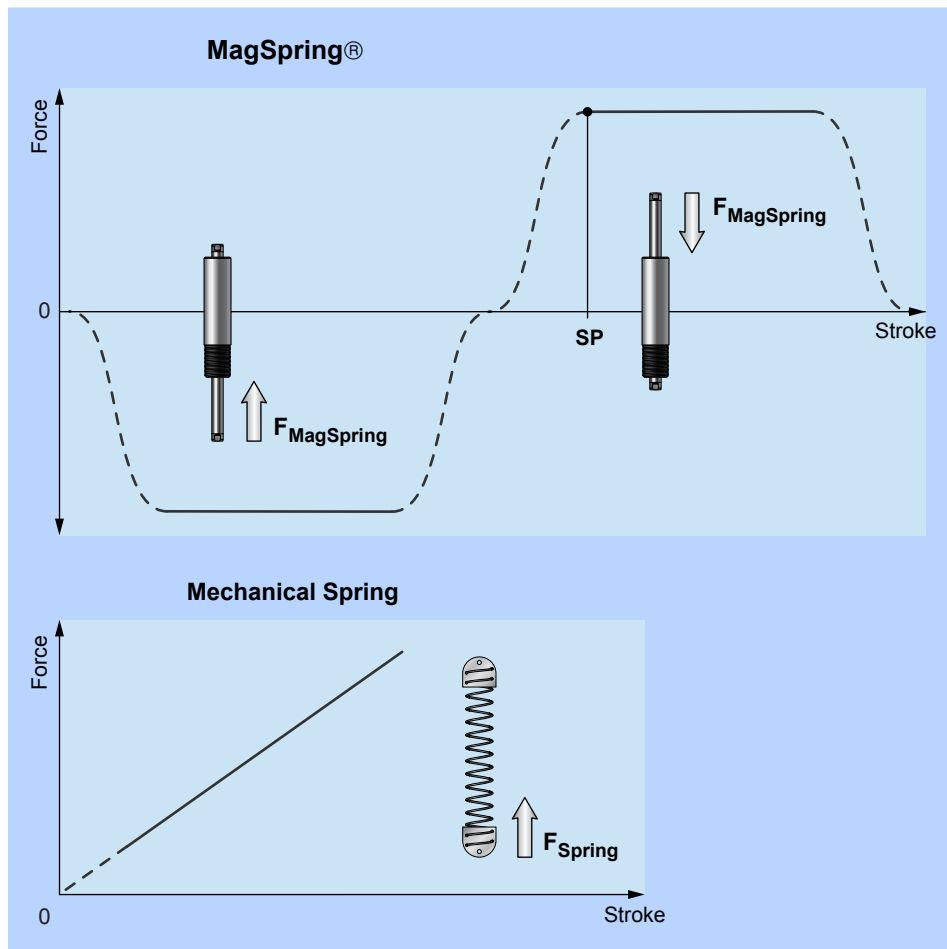

Working Range

In the relaxed state, the slider is approximately centered in the stator, while the working end of the slider extends somewhat out of the end of the stator. Fundamentally, however, both ends of the slider can be used to mount loads. From this rest position, the slider can be pulled or pushed out of the stator in both directions. The force in

creases from zero to the nominal force within a short stroke length. The working stroke then continues with a constant force. The start position (SP) describes the distance between the working end of the slider and the end of the stator at the beginning of the constant force range.

Mounting

The stators can be mounted via the screw thread, or with a clamp, as desired. There are appropriate mounting flanges for both sizes.

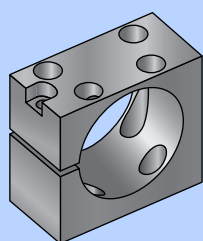

When attaching the slider to the load mass, care should be taken that any parallelism errors are compensated for with a flexible coupler.

Combination with H-Guides

The above illustration shows a vertical arrangement of an H01 linear guide together with a MagSpring. The MagSpring presses upward with a constant force. The weight load is balanced by the MagSpring, and the linear motor thus bears less load.

If the electrical power supply is interrupted, the MagSpring supports the load, or moves it into a safe waiting position.

Materials



Slider:
Chromium-Nickel Steel 1.4301



Stator:
Iron, electroless nickel plated



Bearing:
POM based

M01-20x60/50: Force 11-22N / Stroke 50mm

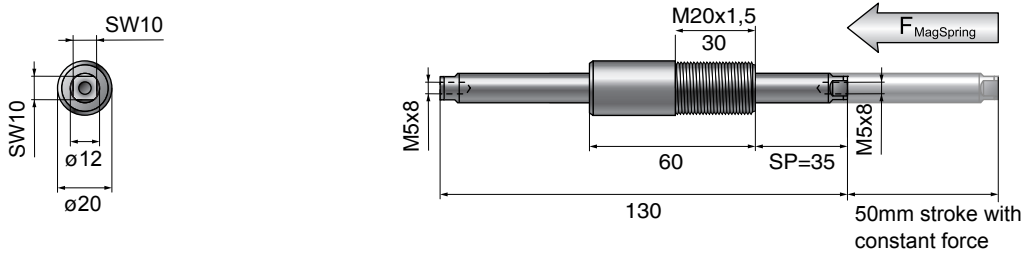

Dimensions in mm

The MagSpring has a constant force, as soon as the slider has been pulled out or pushed by the distance SP. The distance SP is measured between the unmarked slider end and the end of the stator (threaded end).

MagSpring	Constant force [N]	Stator mass [g (lb)]	Slider mass [g (lb)]
M01-20x60/50-11	11	75 (0.16)	75 (0.16)
M01-20x60/50-17	17	75 (0.16)	75 (0.16)
M01-20x60/50-22	22	75 (0.16)	75 (0.16)

M01-20x140/130: Force 11-22N / Stroke 130mm

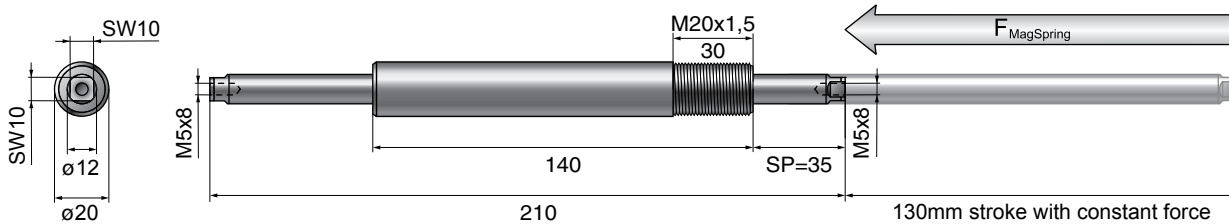

Dimensions in mm

The MagSpring has a constant force, as soon as the slider has been pulled out or pushed by the distance SP. The distance SP is measured between the unmarked slider end and the end of the stator (threaded end).

MagSpring	Constant force [N]	Stator mass [g (lb)]	Slider mass [g (lb)]
M01-20x140/130-11	11	180 (0.39)	155 (0.34)
M01-20x140/130-17	17	180 (0.39)	155 (0.34)
M01-20x140/130-22	22	180 (0.39)	155 (0.34)

M01-20x220/210: Force 11-22N / Stroke 210mm

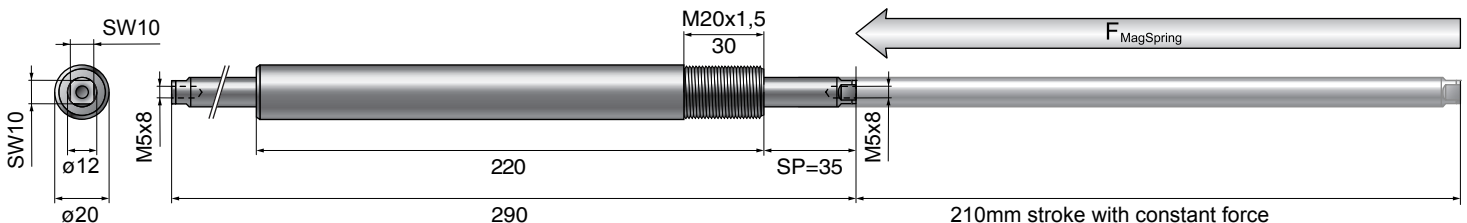

Dimensions in mm

The MagSpring has a constant force, as soon as the slider has been pulled out or pushed by the distance SP. The distance SP is measured between the unmarked slider end and the end of the stator (threaded end).

MagSpring	Constant force [N]	Stator mass [g (lb)]	Slider mass [g (lb)]
M01-20x220/210-11	11	285 (0.62)	220 (0.49)
M01-20x220/210-17	17	285 (0.62)	220 (0.49)
M01-20x220/210-22	22	285 (0.62)	220 (0.49)

M01-20x300/290: Force 11-22N / Stroke 290mm

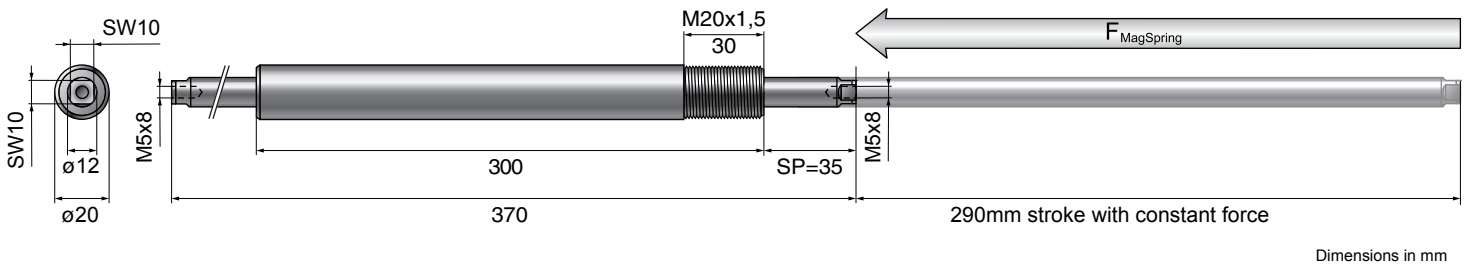

The MagSpring has a constant force, as soon as the slider has been pulled out or pushed by the distance SP. The distance SP is measured between the unmarked slider end and the end of the stator (threaded end).

MagSpring	Constant force [N]	Stator mass [g (lb)]	Slider mass [g (lb)]
M01-20x300/290-11	11	388 (0.86)	280 (0.61)
M01-20x300/290-17	17	388 (0.86)	280 (0.61)
M01-20x300/290-22	22	388 (0.86)	280 (0.61)



Ordering Information

M01-20x60/50	MagSpring M01-20 with 50mm stroke			
Stator	MS01-20x60	MagSpring Stator 20x60mm		0250-2200
Slider	ML01-12x130/80-10	Slider for MagSpring M01-20x60/50, Force 11N		0250-2300
	ML01-12x130/80-15	Slider for MagSpring M01-20x60/50, Force 17N		0250-2308
	ML01-12x130/80-20	Slider for MagSpring M01-20x60/50, Force 22N		0250-2301
M01-20x140/130	MagSpring M01-20 with 130mm stroke			
Stator	MS01-20x140	MagSpring Stator 20x140mm		0250-2201
Slider	ML01-12x210/160-10	Slider for MagSpring M01-20x140/130, Force 11N		0250-2302
	ML01-12x210/160-15	Slider for MagSpring M01-20x140/130, Force 17N		0250-2309
	ML01-12x210/160-20	Slider for MagSpring M01-20x140/130, Force 22N		0250-2303
M01-20x220/210	MagSpring M01-20 with 210mm stroke			
Stator	MS01-20x220	MagSpring Stator 20x220mm		0250-2202
Slider	ML01-12x290/240-10	Slider for MagSpring M01-20x220/210, Force 11N		0250-2304
	ML01-12x290/240-15	Slider for MagSpring M01-20x220/210, Force 17N		0250-2310
	ML01-12x290/240-20	Slider for MagSpring M01-20x220/210, Force 22N		0250-2305
M01-20x300/290	MagSpring M01-20 with 290mm stroke			
Stator	MS01-20x300	MagSpring Stator 20x300mm		0250-2207
Slider	ML01-12x370/320-10	Slider for MagSpring M01-20x300/290, Force 11N		0250-2311
	ML01-12x370/320-15	Slider for MagSpring M01-20x300/290, Force 17N		0250-2312
	ML01-12x370/320-20	Slider for MagSpring M01-20x300/290, Force 22N		0250-2313

M01-37x80/50: Force 40-60N / Stroke 50mm

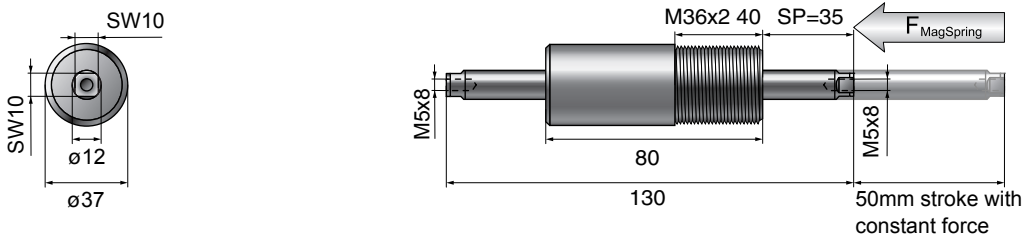

Dimensions in mm

The MagSpring has a constant force, as soon as the slider has been pulled out or pushed by the distance SP. The distance SP is measured between the unmarked slider end and the end of the stator (threaded end).

MagSpring	Constant force [N]	Stator mass [g (lb)]	Slider mass [g (lb)]
M01-37x80/50-40	40	440 (0.90)	75 (0.16)
M01-37x80/50-50	50	440 (0.90)	75 (0.16)
M01-37x80/50-60	60	440 (0.90)	75 (0.16)

M01-37x155/125: Force 40-60N / Stroke 125mm

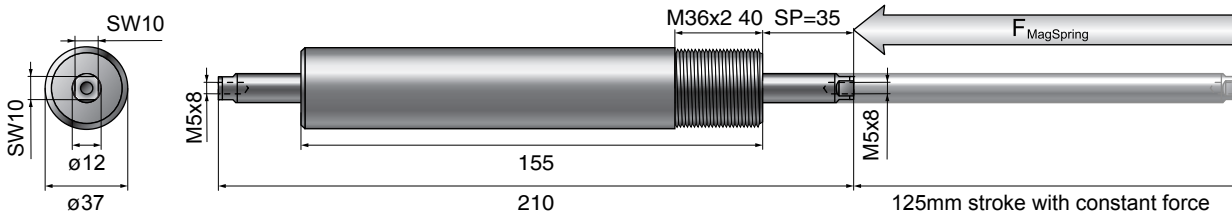

Dimensions in mm

The MagSpring has a constant force, as soon as the slider has been pulled out or pushed by the distance SP. The distance SP is measured between the unmarked slider end and the end of the stator (threaded end).

MagSpring	Constant force [N]	Stator mass [g (lb)]	Slider mass [g (lb)]
M01-37x155/125-40	40	880 (1.80)	155 (0.34)
M01-37x155/125-50	50	880 (1.80)	155 (0.34)
M01-37x155/125-60	60	880 (1.80)	155 (0.34)

M01-37x230/200: Force 40-60N / Stroke 200mm

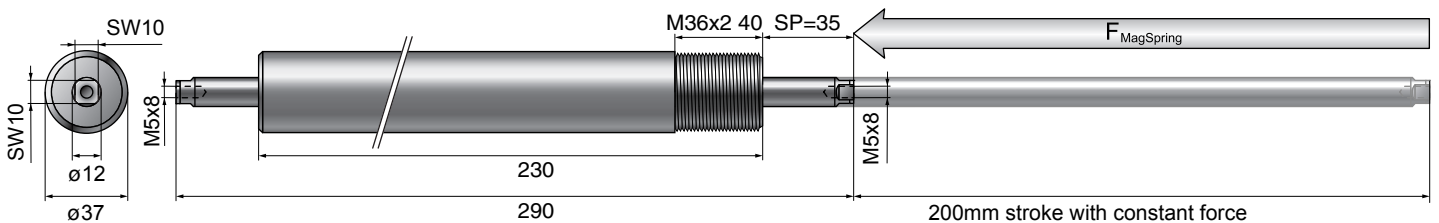

Dimensions in mm

The MagSpring has a constant force, as soon as the slider has been pulled out or pushed by the distance SP. The distance SP is measured between the unmarked slider end and the end of the stator (threaded end).

MagSpring	Constant force [N]	Stator mass [g (lb)]	Slider mass [g (lb)]
M01-37x230/200-40	40	1320 (2.70)	220 (0.49)
M01-37x230/200-50	50	1320 (2.70)	220 (0.49)
M01-37x230/200-60	60	1320 (2.70)	220 (0.49)

M01-37x305/275: Force 40-60N / Stroke 275mm

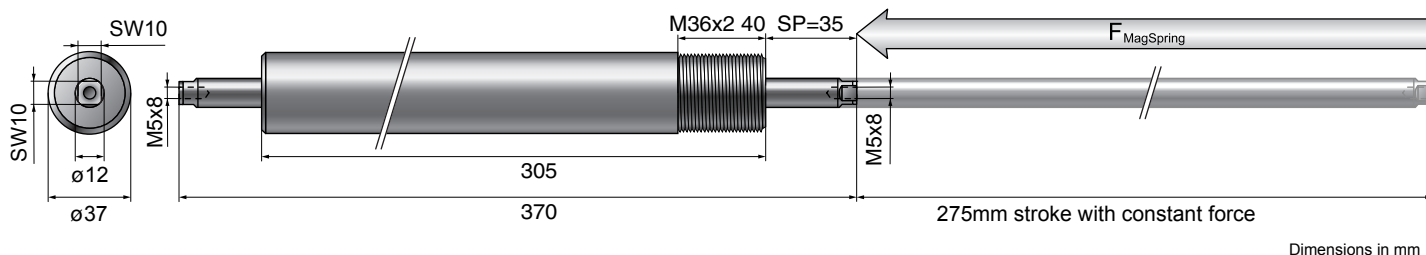

Dimensions in mm

The MagSpring has a constant force, as soon as the slider has been pulled out or pushed by the distance SP. The distance SP is measured between the unmarked slider end and the end of the stator (threaded end).

MagSpring	Constant force [N]	Stator mass [g (lb)]	Slider mass [g (lb)]
M01-37x305/275-40	40	1800 (3.90)	280 (0.61)
M01-37x305/275-50	50	1800 (3.90)	280 (0.61)
M01-37x305/275-60	60	1800 (3.90)	280 (0.61)



Ordering Information

M01-37x80/50	MagSpring M01-37 with 50mm stroke			
Stator	MS01-37x80	MagSpring Stator 37x80mm		0250-2203
Slider	ML01-12x130/80-10	Slider for MagSpring M01-37x80/50, Force 40N		0250-2300
	ML01-12x130/80-15	Slider for MagSpring M01-37x80/50, Force 50N		0250-2308
	ML01-12x130/80-20	Slider for MagSpring M01-37x80/50, Force 60N		0250-2301
M01-37x155/125	MagSpring M01-37 with 125mm stroke			
Stator	MS01-37x155	MagSpring Stator 37x155mm		0250-2204
Slider	ML01-12x210/160-10	Slider for MagSpring M01-37x155/125, Force 40N		0250-2302
	ML01-12x210/160-15	Slider for MagSpring M01-37x155/125, Force 50N		0250-2309
	ML01-12x210/160-20	Slider for MagSpring M01-37x155/125, Force 60N		0250-2303
M01-37x230/200	MagSprings M01-37 with 200mm stroke			
Stator	MS01-37x230	MagSpring Stator 37x230mm		0250-2205
Slider	ML01-12x290/240-10	Slider for MagSpring M01-37x230/200, Force 40N		0250-2304
	ML01-12x290/240-15	Slider for MagSpring M01-37x230/200, Force 50N		0250-2310
	ML01-12x290/240-20	Slider for MagSpring M01-37x230/200, Force 60N		0250-2305
M01-37x305/275	MagSprings M01-37 with 275mm stroke			
Stator	MS01-37x305	MagSpring Stator 37x305mm		0250-2206
Slider	ML01-12x370/320-10	Slider for MagSpring M01-37x305/275, Force 40N		0250-2311
	ML01-12x370/320-15	Slider for MagSpring M01-37x305/275, Force 50N		0250-2312
	ML01-12x370/320-20	Slider for MagSpring M01-37x305/275, Force 60N		0250-2313

Accessories

Mounting flanges and adapters are available for mounting MagSpring magnetic springs. Using these accessories, the magnetic springs can be mounted directly on an H01 linear guide or a B01 bridge guide.

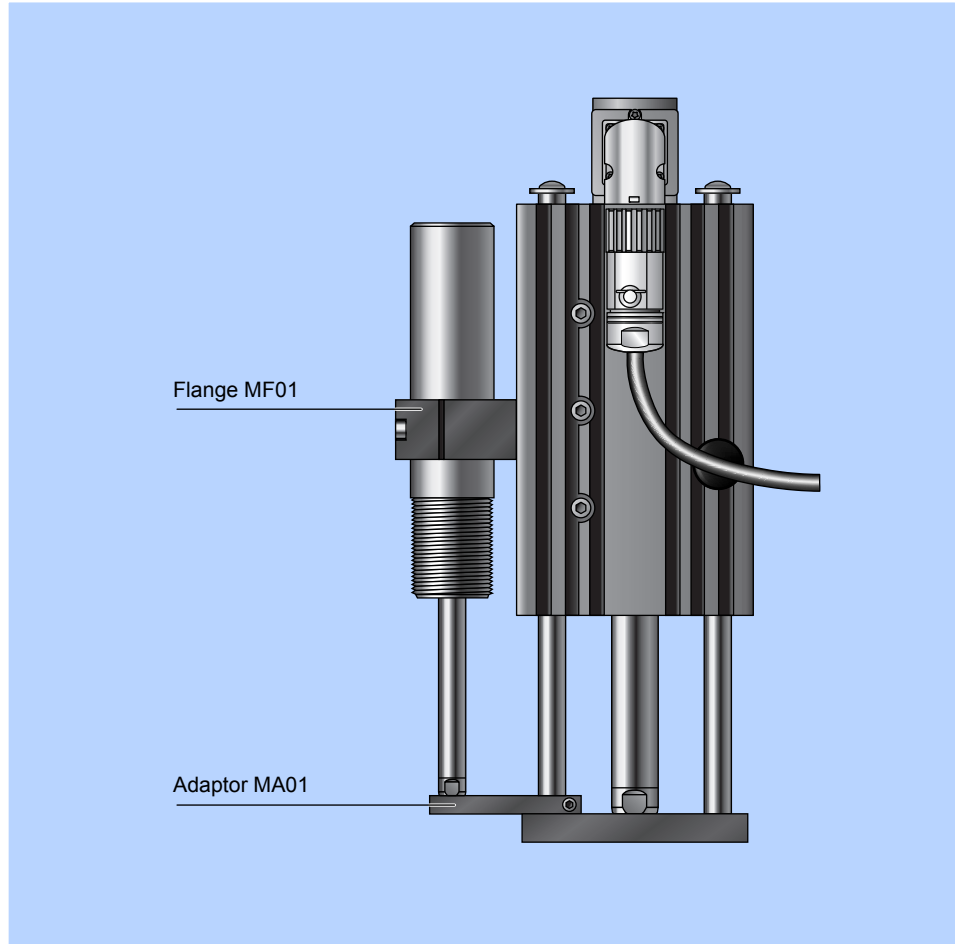

Mounting

The flange for mounting the MagSpring starters is secured with T-nuts in the T-slot provided for this purpose on the linear or bridge guide.

For weight balancing in vertical installations, the lower slider end of the MagSpring is attached to the guide shaft of the guide using the adapter.

Depending on the installation orientation of the guide, the adapter is attached to the guide shaft at the front mounting plate (motor on top) or the rear end of the guide shaft (motor on the bottom).

Motor on the top

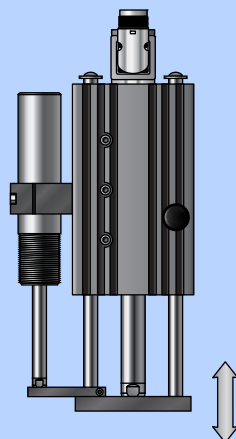

Motor on the bottom

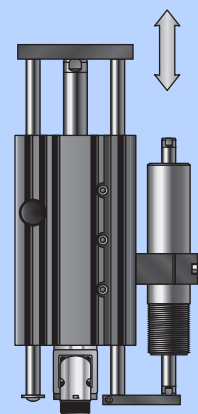

Flange and Adaptor for MagSpring



Flanges for MagSpring M01-20

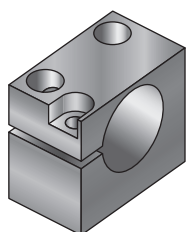
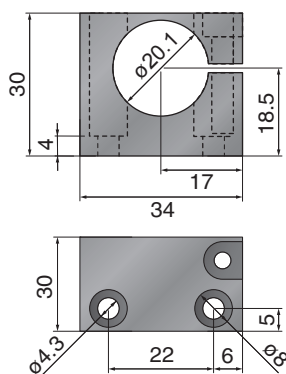

MF01-20/H23

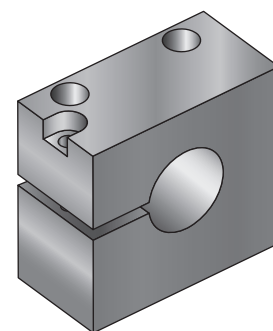
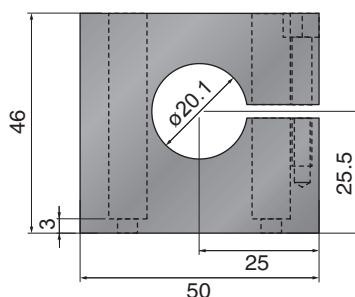

MF01-20/H37

Material: Aluminum (AlMgSi), black anodized
 Mass: MF01-20/H23 approx. 30g (0.066lb)
 MF01-20/H37 approx. 125g (0.276lb)

Dimensions in mm

Item	Description	Part Number
MF01-20/H23	Flange MagSpring M01-20 - fits guides H01-23	0250-2306
MF01-20/H37	Flange MagSpring M01-20 - fits guides H01-37	0250-2315

Flange for MagSpring M01-37

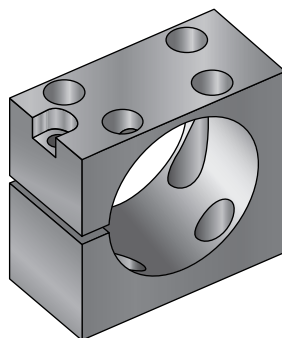
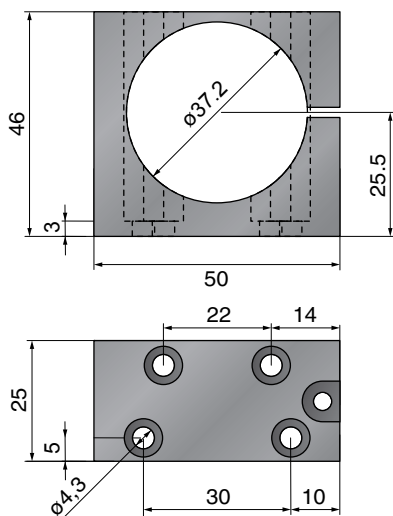

Material: Aluminum (AlMgSi), black anodized
 Mass: approx. 70g (0.15lb)

Dimensions in mm

Item	Description	Part Number
MF01-37/H37	Flange MagSpring M01-37 - fits guides H01-37 and B01-37 - fits guides H01-48 and B01-48	0250-2307

Adaptor for MagSpring M01-20 and Guides H01-23

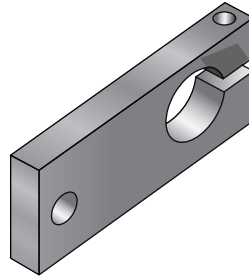
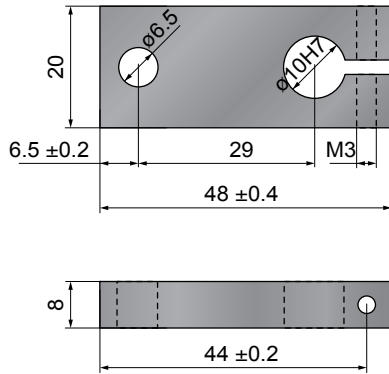

Material: Aluminum (AlMgSi), black anodized
Mass: approx. 18g (0.066lb)

Dimensions in mm

Item	Description	Part Number
MA01-20/H23	Adaptor MagSpring M01-20 / Guides H01-23	0250-0116

Adaptor for MagSpring M01-37 and Guides H01-37 / B01-37

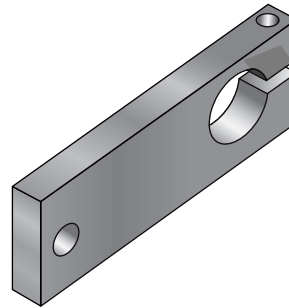
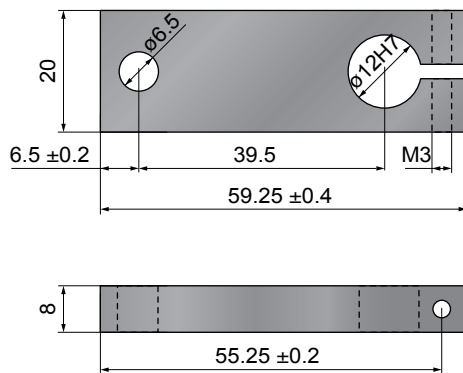

Material: Aluminum (AlMgSi), black anodized
Mass: approx. 18g (0.066lb)

Dimensions in mm

Item	Description	Part Number
MA01-37/H37	Adaptor MagSpring M01-37 / Guides H01-37 and B01-37	0250-0117

Adaptor for MagSpring M01-37 and Guides H01-48 / B01-48

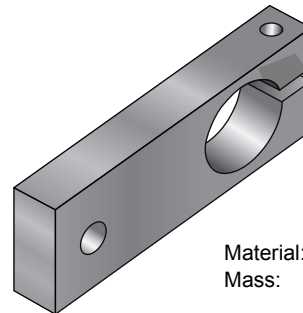
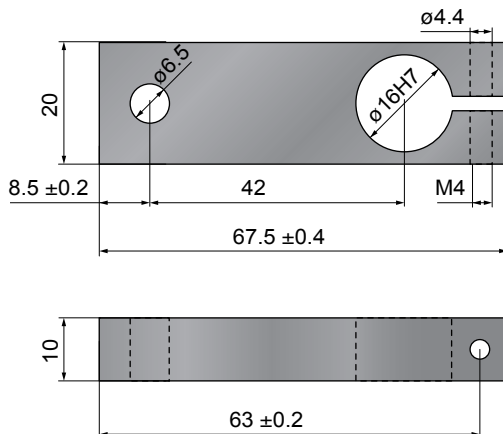

Material: Aluminum (AlMgSi), black anodized
Mass: approx. 32g (0.034lb)

Dimensions in mm

Item	Description	Part Number
MA01-37/H48	Adaptor MagSpring M01-37 / Guides H01-48 and B01-48	0250-0118

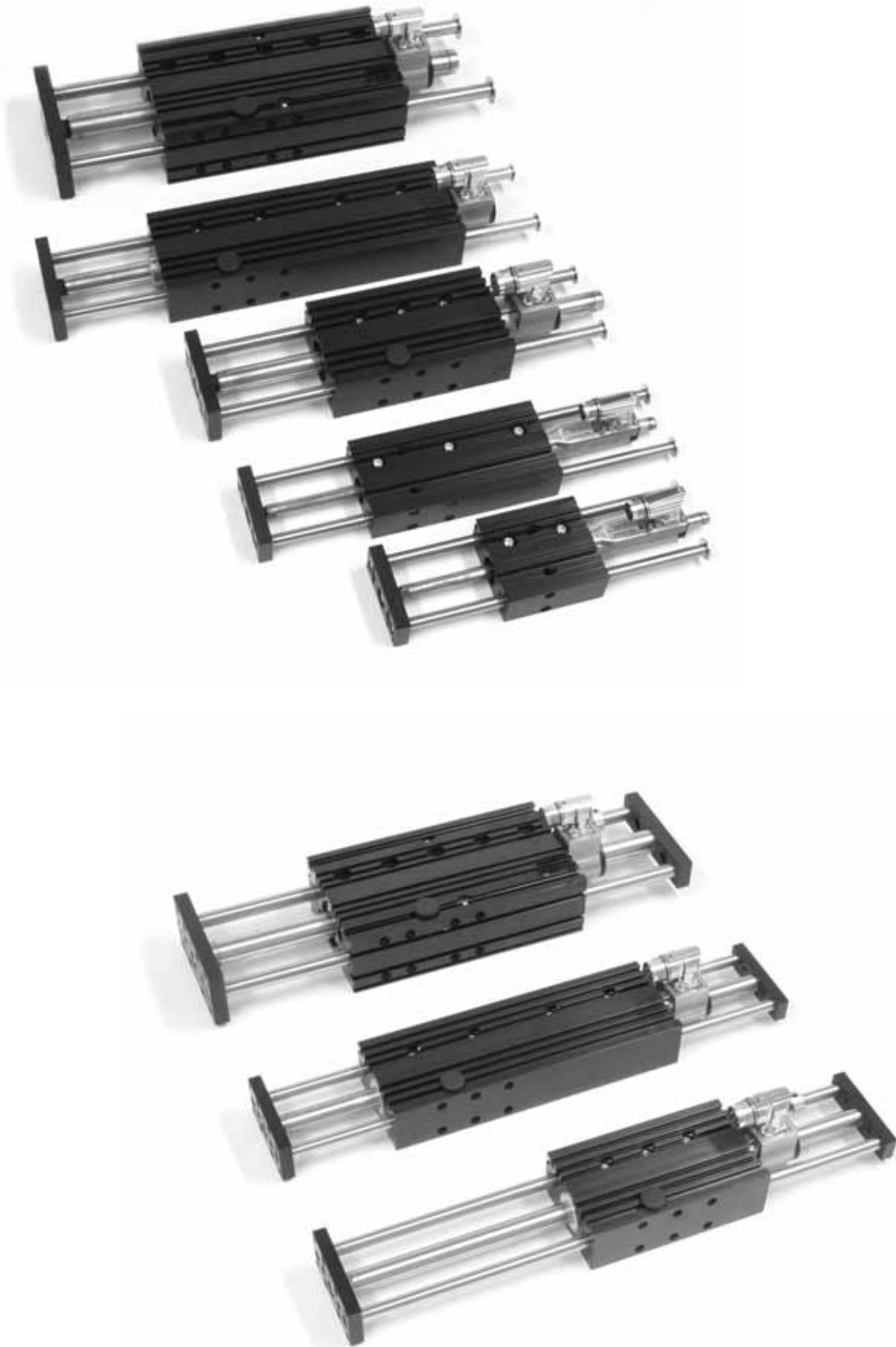



Linear Guides H01-23x86

482

Linear Guides H01-23X166

484

Linear Guides H01-37X166

486

Linear Guides H01-37x286

488

Linear Guides H01-48x250

490

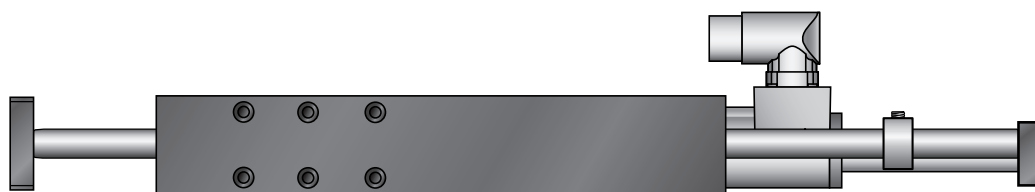

Bridge Guides B01-37X166

496

Bridge Guides B01-37x286

498

Bridge Guides B01-48x250

500

Linear Guides

Series H01 Linear Guides are compact guide units with integrated ball bearings or plain bushings, for operating LinMot P01 linear motors with standard or heavy duty sliders.

H01 Linear Guides are used as load bearings, to resist external forces and rotational and bending moments, and as an anti-rotation device. They provide high-precision guidance and allow dynamic and precise positioning of the load.

The load is mounted directly to the front plate of the linear guide. Mechanical dimensions and mounting options are compatible with pneumatic linear guides. The modular design allows simple addition of accessories, such as a mechanical brake or magnetic spring, for load balancing in vertical applications.



Designation:

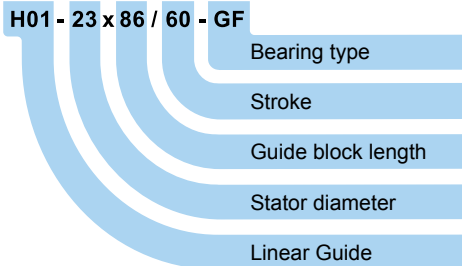

Mechanical Compatibility

LinMot H01 guides are mechanically compatible with pneumatic H-guides.

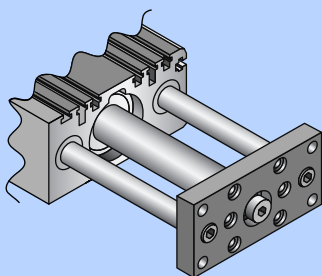

This allows simple replacement with a new drive technology, if more flexibility or higher dynamics are required.

Ball Bearings

Use of linear guides with ball bearings is recommended for standard applications under normal environmental conditions.

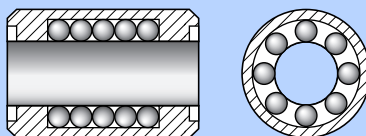

Linear guides with ball bearings have very good running characteristics, and ensure nearly frictionless operation.

Sintered Bushings

For applications in very dirty, damp, or wet environments, the use of linear guides with plain bushings and stainless steel shafts is recommended.

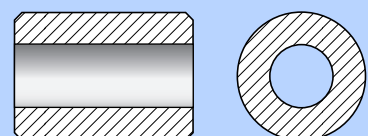

For highly dynamic applications with accelerations over 50 m/s², the use of linear modules with plain bushings is also recommended.

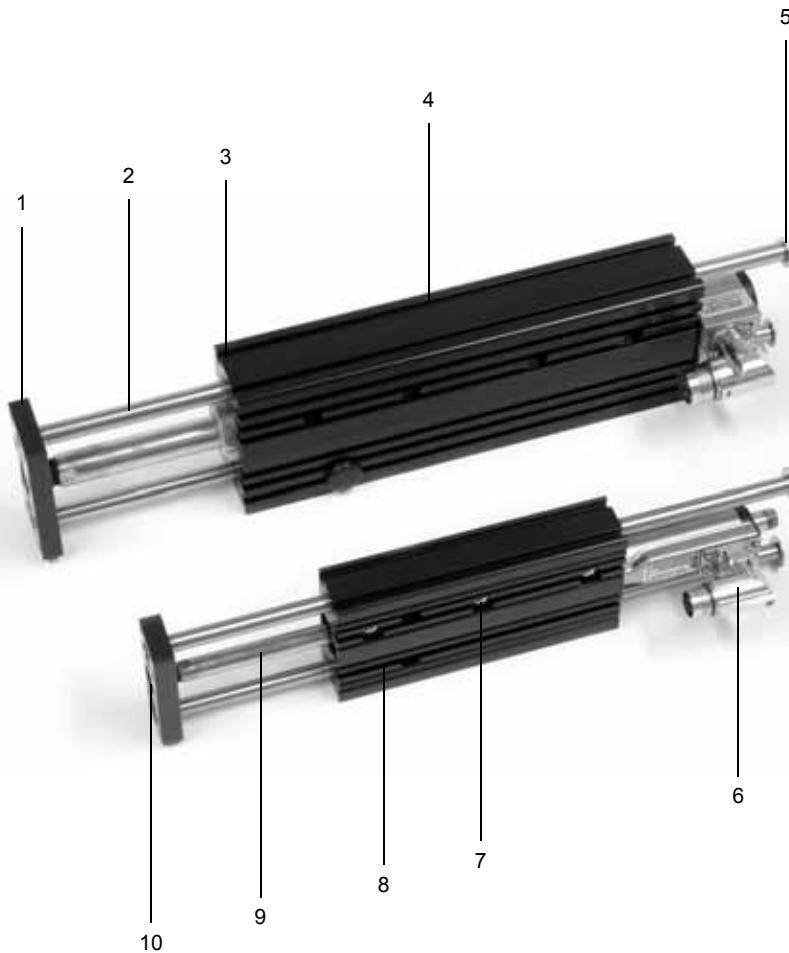

1. Mounting plate with counter bore for precise load mounting
2. Hardened or stainless steel shafts for precise positioning and quiet operation.
3. Ball bearings or sintered bushings, for high load masses and long life
4. Guide block with counter bores for uncomplicated, precise mounting of the Linear Module.
5. Mechanical end stop (rear).
6. Linear motor stator with integrated bearings, temperature and position sensors. Available with IP67 connector or cable exit.
7. Clamping cylinder to secure the stator in the guide block.
8. T-slots in the guide block allow simple mounting of accessories.
9. Linear motor slider, guarantees maximum force and precise positioning.
10. Integrated linear coupling for simple mounting of the slider.

Linear Module LM01

Complete LM01 linear modules, consisting of a H01 guide and P01 linear motor, are highly dynamic design components. Compact construction and free positioning have significant advantages, especially in textile and packaging machines, assembly and feeding technology, laboratory automation, and special machines and systems.



Designation:

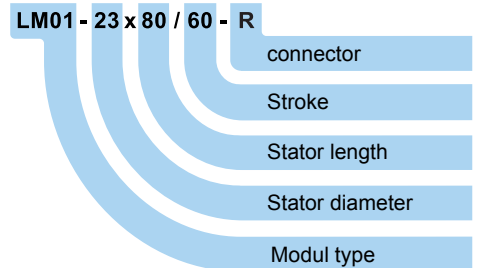

Brake Option

As an option, H01-37 and H01-48 guides can have a mechanical brake attached.

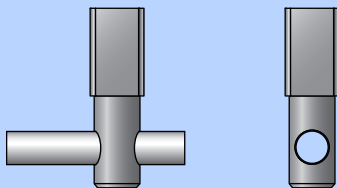

The pneumatic brake is controlled by the E1100 Servo Drive. The brake acts on the guide shafts of the linear guide, and is released under air pressure (4-6 bar). With no air pressure, the brake is on.

MagSpring Option

In vertical applications, a MagSpring can be used as a weight balancer.

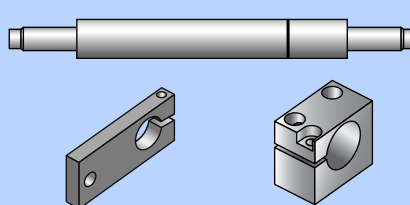

The MagSpring also prevents the linear motor from falling to the lower end stop if the linear motor is turned off or the power is lost. Appropriate accessories are available for mounting the magnetic spring.

Fan Option

With an additional fan, the holding force of the linear motor can be nearly doubled.

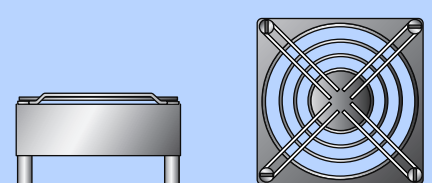

If needed, the optional fan can be mounted directly on the guide.

Linear module LM01-23X80

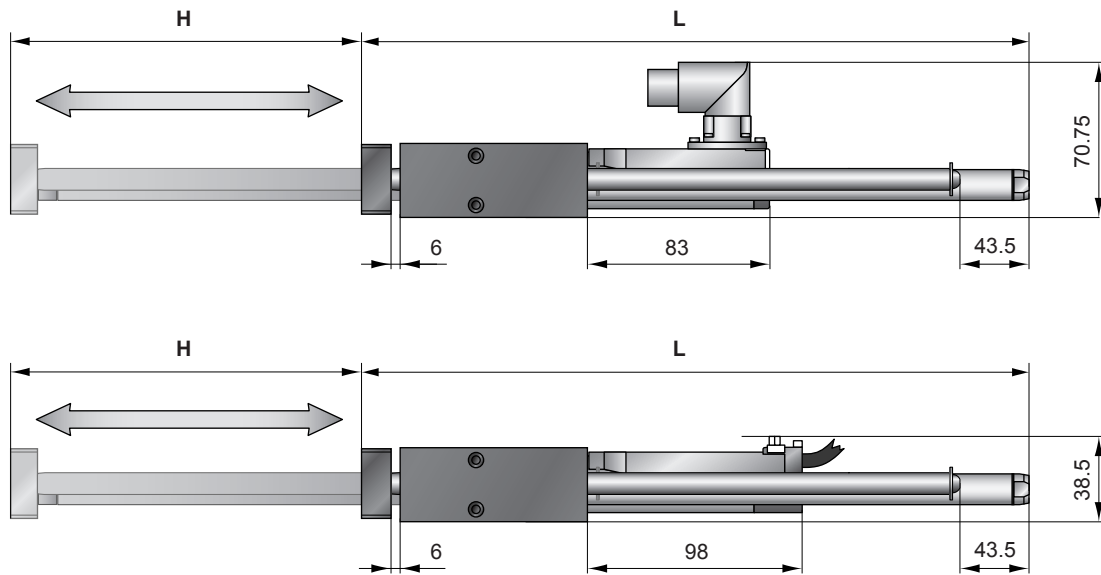

Linear Module	Bearing	Stroke H [mm (inch)]	Moving Parts L [mm (inch)]	Moving Mass ¹⁾ [g (lb)]	Total Weight ¹⁾ [g (lb)]
LM01-23x80/60	Ball Bearings	60 (2.36)	205.5 (8.09)	405 (0.89)	1100 (2.43)
LM01-23x80/160	Ball Bearings	160 (6.30)	305.5 (12.03)	610 (1.34)	1310 (2.88)
LM01-23x80/260	Ball Bearings	260 (10.24)	435.5 (17.15)	860 (1.90)	1560 (2.43)
LM01-23x80/60-GF	Plain Bushings	60 (2.36)	205.5 (8.07)	405 (0.89)	1100 (2.43)
LM01-23x80/160-GF	Plain Bushings	160 (6.30)	305.5 (12.03)	610 (1.34)	1310 (2.88)
LM01-23x80/260-GF	Plain Bushings	260 (10.24)	435.5 (17.15)	860 (1.90)	1560 (2.43)

¹⁾ linear guide with linear motor

Linear Guides H01-23x86

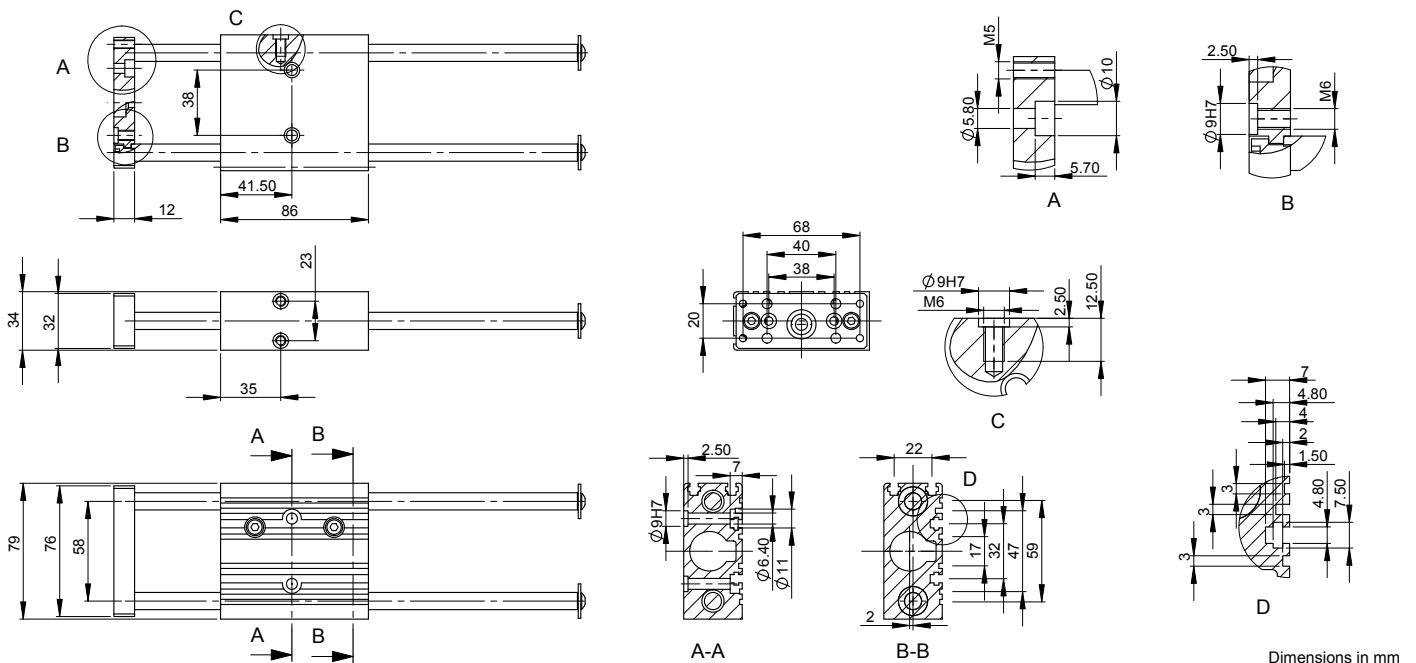

Dimensions in mm

Materials	Guide Block & Front Plate	Guide Shaft	Bearing	Wipers	
H01-23x86/...	Ball Bearings	Anodized Aluminum	Hardened Steel	Steel	Nitrile Rubber
H01-23x86/...-GF	Plain Bushings	Anodized Aluminum	Stainless Steel 1.4104	Sintered Bronze	Nitrile Rubber

Positioning Times with LM01-23X80

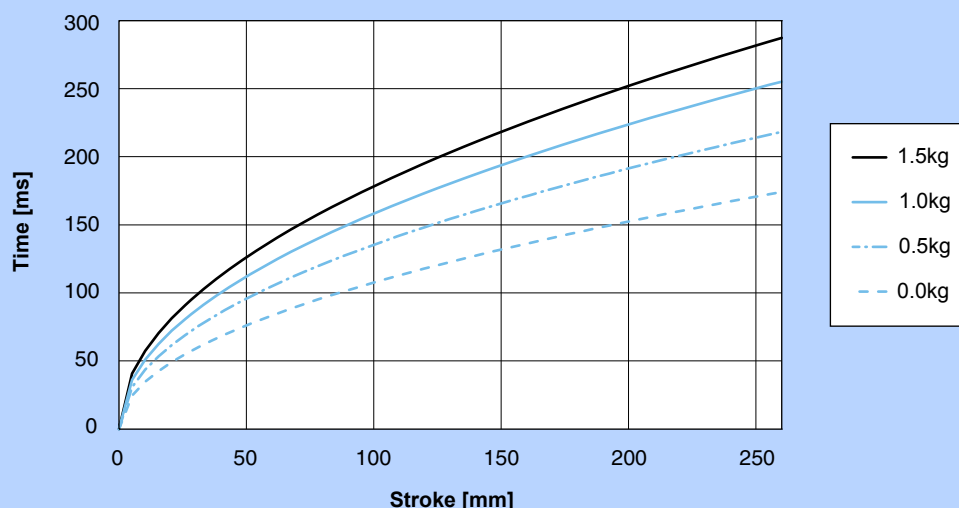

Minimum positioning times for horizontal motions with different load masses, controlled by an E1100-HC Servo Drive.

Ordering Information

LM01-23x80/60		Linear Module 23x80 with 60mm Stroke		
Linear Guide	H01-23x86/60	H01 for P01-23x80, 60mm Stroke, Ball Bearings	0150-5014	
	H01-23x86/60-GF	H01 for P01-23x80, 60mm Stroke, Plain Bushings	0150-5074	
Stator	PS01-23x80-R	Linear motor stator, connector R - IP67	0150-1233	
	PS01-23x80-R20	Linear motor stator, 0.2m Cable, connector R - IP67	0150-1241	
	PS01-23x80	Linear motor stator, 1.0m Cable, connector D	0150-1201	
Slider	PL01-12x190/140	Standard Slider for H01-23x86/60	0150-1302	

LM01-23x80/160		Linear Module 23x80 with 160mm Stroke		
Linear Guide	H01-23x86/160	H01 for P01-23x80, 160mm Stroke, Ball Bearings	0150-5015	
	H01-23x86/160-GF	H01 for P01-23x80, 160mm Stroke, Plain Bushings	0150-5075	
Stator	PS01-23x80-R	Linear motor stator, connector R - IP67	0150-1233	
	PS01-23x80-R20	Linear motor stator, 0.2m Cable, connector R - IP67	0150-1241	
	PS01-23x80	Linear motor stator, 1.0m Cable, connector D	0150-1201	
Slider	PL01-12x290/240	Standard Slider for H01-23x86/160	0150-1320	

LM01-23x80/260		Linear Module 23x80 with 260mm Stroke		
Linear Guide	H01-23x86/260	H01 for P01-23x80, 260mm Stroke, Ball Bearings	0150-5016	
	H01-23x86/260-GF	H01 for P01-23x80, 260mm Stroke, Plain Bushings	0150-5076	
Stator	PS01-23x80-R	Linear motor stator, connector R - IP67	0150-1233	
	PS01-23x80-R20	Linear motor stator, 0.2m Cable, connector R - IP67	0150-1241	
	PS01-23x80	Linear motor stator, 1.0m Cable, connector D	0150-1201	
Slider	PL01-12x420/370	Standard Slider for H01-23x86/260	0150-1324	

Accessories

Fan	HV01-23	Fan for H01-23 Linear Guides	0150-5050
MagSpring	MF01-20/H23	Mounting flange for MagSpring M01-20x...	0250-2306
	MA01-20/H23	Mounting adapter for MagSpring M01-20x...	0250-0116
Center Sleeve	HC01-09/04	Center Sleeve D9x4mm	0150-3251

Linear module LM01-23X160

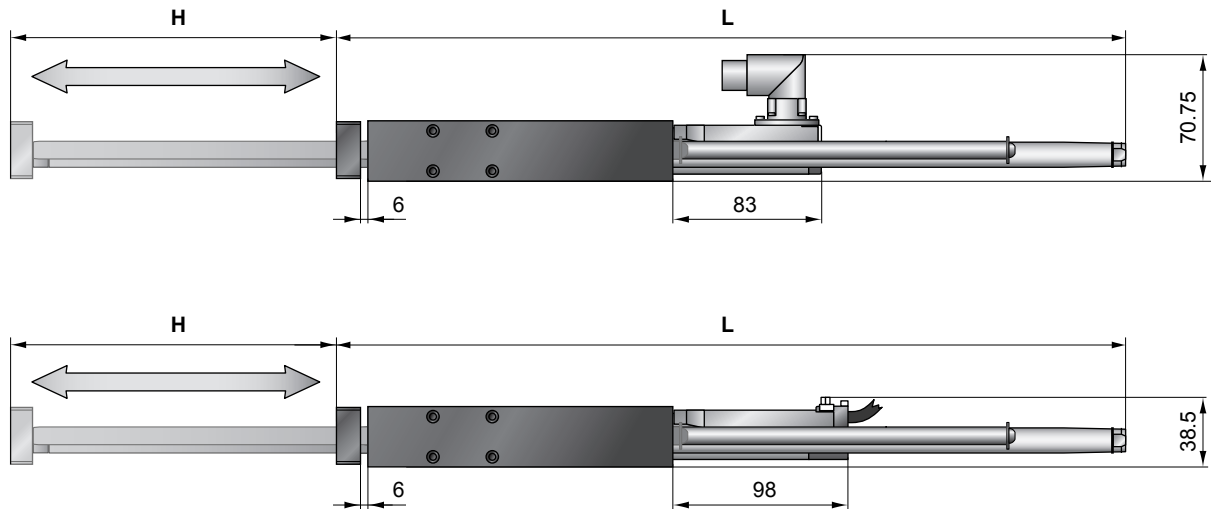

Linear Module	Bearing	Stroke H [mm (inch)]	Moving Parts L [mm (inch)]	Moving Mass ¹⁾ [g (lb)]	Total Weight ¹⁾ [g (lb)]
LM01-23X160/80	Ball Bearings	80 (3.15)	305.5 (12.03)	610 (1.34)	1890 (4.17)
LM01-23X160/180	Ball Bearings	180 (7.09)	435.5 (17.15)	860 (1.90)	2140 (4.72)
LM01-23X160/280	Ball Bearings	280 (11.02)	495.5 (19.51)	1020 (2.25)	2300 (5.07)
LM01-23X160/80-GF	Plain Bushings	80 (3.15)	305.5 (12.03)	610 (1.34)	1890 (4.17)
LM01-23X160/180-GF	Plain Bushings	180 (7.09)	435.5 (17.15)	860 (1.90)	2140 (4.72)
LM01-23X160/280-GF	Plain Bushings	280 (11.02)	495.5 (19.51)	1020 (2.25)	2300 (5.07)

¹⁾ linear guide with linear motor

Linear Guides H01-23X166

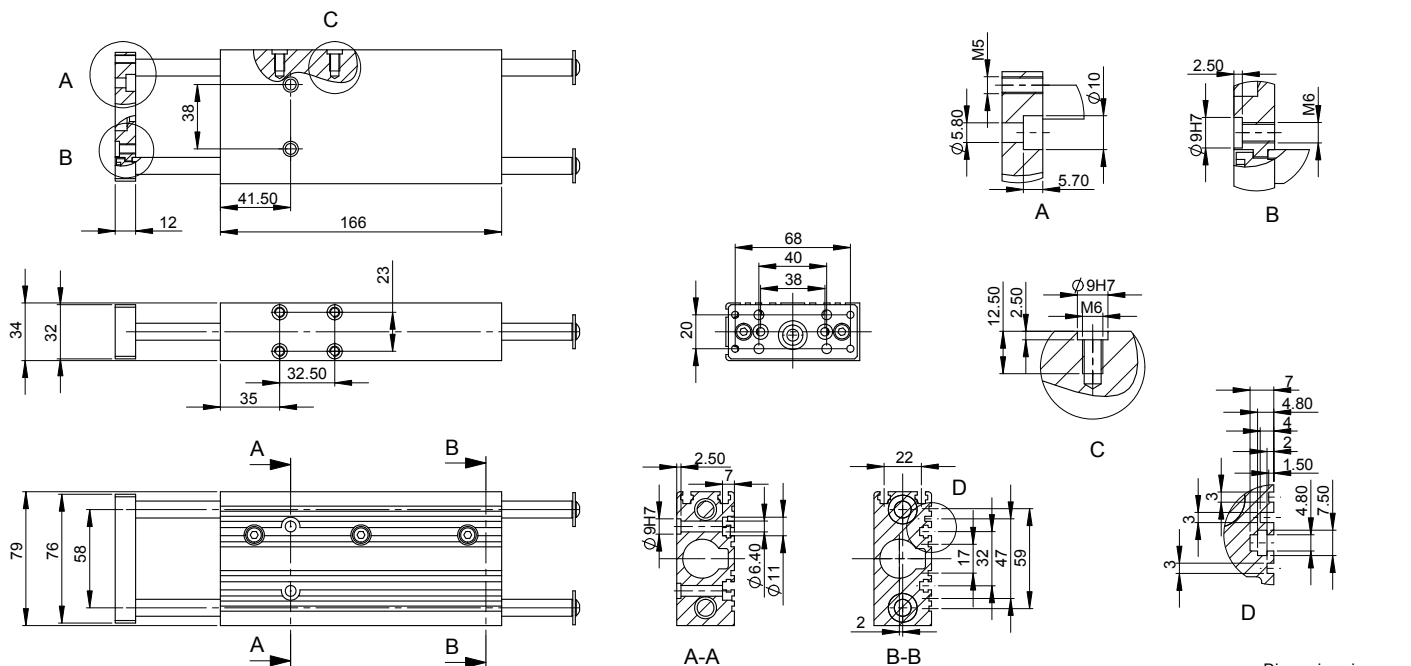

Dimensions in mm

Materials	Guide Block & Front Plate	Guide Shaft	Bearing	Wipers	
H01-23x166/...	Ball Bearings	Anodized Aluminum	Hardened Steel	Steel	Nitrile Rubber
H01-23x166/...-GF	Plain Bushings	Anodized Aluminum	Stainless Steel 1.4104	Sintered Bronze	Nitrile Rubber

Positioning Times with LM01-23X160

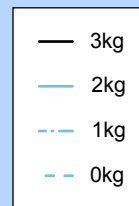
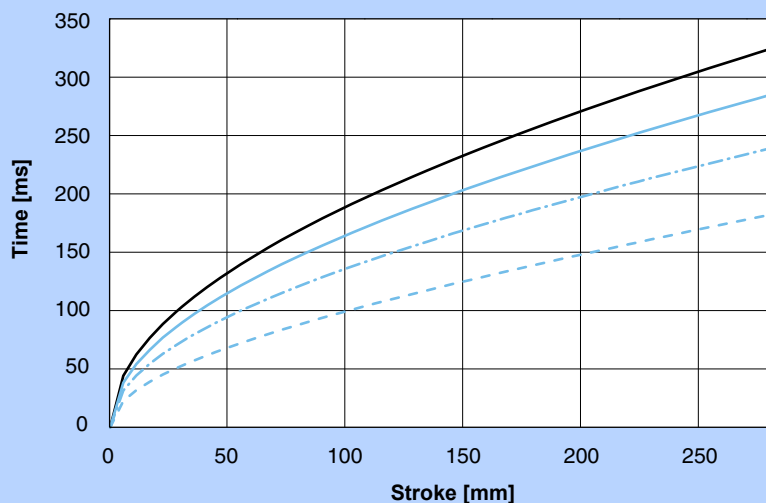

Minimum positioning times for horizontal motions with different load masses, controlled by an E1100-HC Servo Drive.

Ordering Information

LM01-23x160/80		Linear Module 23x160 with 80mm Stroke		
Linear Guide	H01-23x166/80	H01 for P01-23x160, 80mm Stroke, Ball Bearings		0150-5017
	H01-23x166/80-GF	H01 for P01-23x160, 80mm Stroke, Plain Bushings		0150-5077
Stator	PS01-23x160-R	Linear motor stator, connector R - IP67		0150-1234
	PS01-23x160F-R	Linear motor stator, connector R - IP67	Fast Winding	0150-1235
	PS01-23x160-R20	Linear motor stator, 0.2m Cable, connector R - IP67		0150-1242
	PS01-23x160F-R20	Linear motor stator, 0.2m Cable, connector R - IP67	Fast Winding	0150-1243
	PS01-23x160	Linear motor stator, 1.0m Cable, connector D		0150-1202
Slider	PL01-12x290/240	Standard Slider for H01-23x166/80		0150-1320
LM01-23x160/180		Linear Module 23x160 with 180mm Stroke		
Linear Guide	H01-23x166/180	H01 for P01-23x160, 180mm Stroke, Ball Bearings		0150-5018
	H01-23x166/180-GF	H01 for P01-23x160, 180mm Stroke, Plain Bushings		0150-5078
Stator	PS01-23x160-R	Linear motor stator, connector R - IP67		0150-1234
	PS01-23x160F-R	Linear motor stator, connector R - IP67	Fast Winding	0150-1235
	PS01-23x160-R20	Linear motor stator, 0.2m Cable, connector R - IP67		0150-1242
	PS01-23x160F-R20	Linear motor stator, 0.2m Cable, connector R - IP67	Fast Winding	0150-1243
	PS01-23x160	Linear motor stator, 1.0m Cable, connector D		0150-1202
Slider	PL01-12x420/370	Standard Slider for H01-23x166/180		0150-1324
LM01-23x160/280		Linear Module 23x160 with 280mm Stroke		
Linear Guide	H01-23x166/280	H01 for P01-23x160, 280mm Stroke, Ball Bearings		0150-5019
	H01-23x166/280-GF	H01 for P01-23x160, 280mm Stroke, Plain Bushings		0150-5079
Stator	PS01-23x160-R	Linear motor stator, connector R - IP67		0150-1234
	PS01-23x160F-R	Linear motor stator, connector R - IP67	Fast Winding	0150-1235
	PS01-23x160-R20	Linear motor stator, 0.2m Cable, connector R - IP67		0150-1242
	PS01-23x160F-R20	Linear motor stator, 0.2m Cable, connector R - IP67	Fast Winding	0150-1243
	PS01-23x160	Linear motor stator, 1.0m Cable, connector D		0150-1202
Slider	PL01-12x480/430	Standard Slider for H01-23x166/280		0150-1372
Accessories				
Fan	HV01-23	Fan for H01-23 Linear Guides		0150-5050
MagSpring	MF01-20/H23	Mounting flange for MagSpring M01-20x...		0250-2306
	MA01-20/H23	Mounting adapter for MagSpring M01-20x...		0250-0116
Center Sleeve	HC01-09/04	Center Sleeve D9x4mm		0150-3251

Linear module LM01-37x120

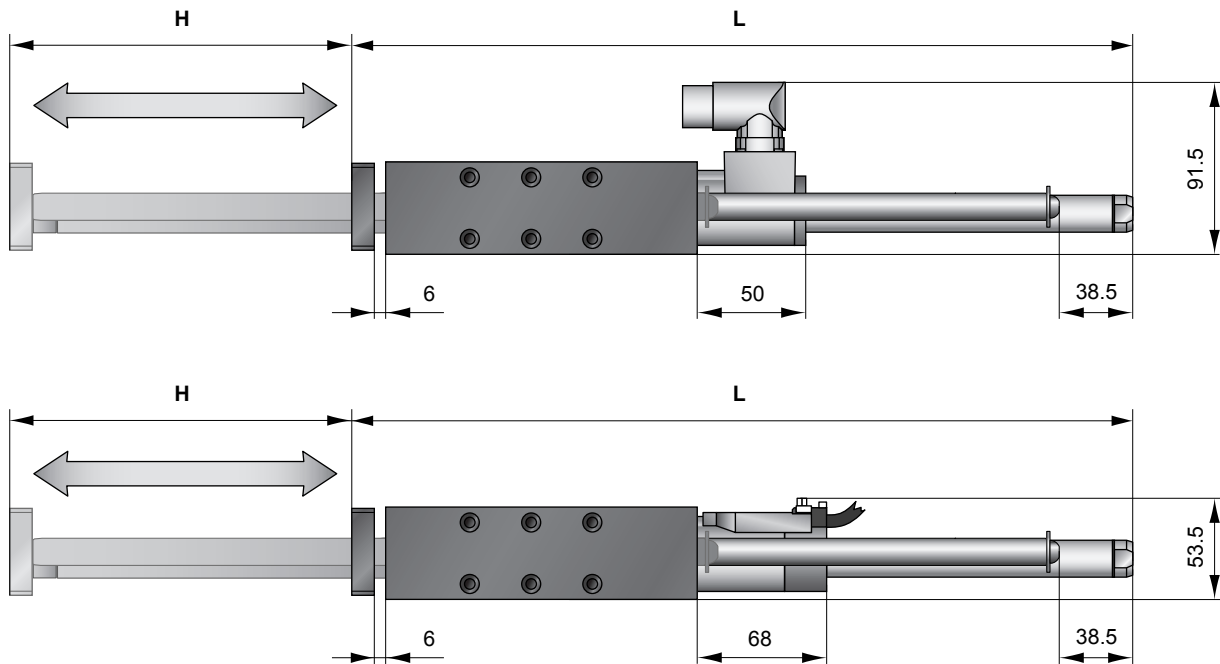

Linear Module	Bearing	Stroke H [mm (inch)]	Moving Parts L [mm (inch)]	Moving Mass ¹⁾ [g (lb)]	Total Weight ¹⁾ [g (lb)]
LM01-37x120/80	Ball Bearings	80 (3.15)	318 (12.52)	1190 (2.62)	3260 (7.18)
LM01-37x120/180	Ball Bearings	180 (7.09)	413 (16.26)	1600 (3.53)	3670 (8.09)
LM01-37x120/280	Ball Bearings	280 (11.02)	518 (20.39)	2030 (4.46)	4100 (9.03)
LM01-37x120/80-GF	Plain Bushings	80 (3.15)	318 (12.52)	1190 (2.62)	3260 (7.18)
LM01-37x120/180-GF	Plain Bushings	180 (7.09)	413 (16.26)	1600 (3.53)	3670 (8.09)
LM01-37x120/280-GF	Plain Bushings	280 (11.02)	518 (20.39)	2030 (4.46)	4100 (9.03)

¹⁾ linear guide with linear motor

Linear Guides H01-37X166

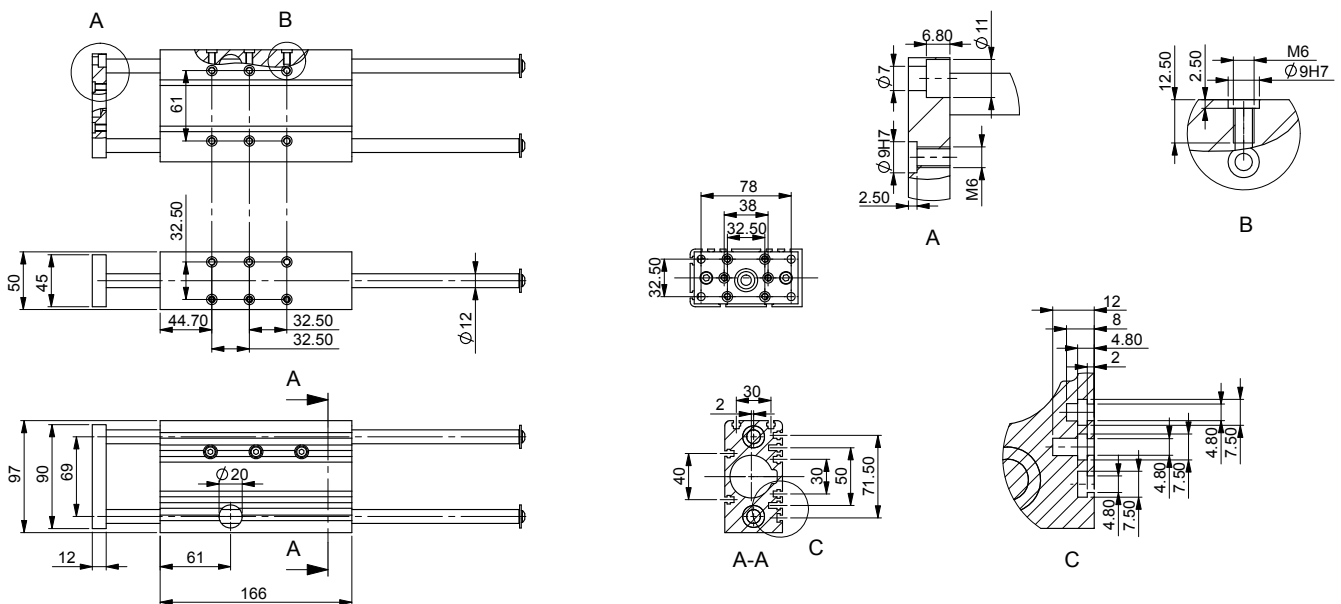

Dimensions in mm

Materials	Guide Block & Front Plate	Guide Shaft	Bearing	Wipers	
H01-37x166/...	Ball Bearings	Anodized Aluminum	Hardened Steel	Steel	Nitrile Rubber
H01-37x166/...-GF	Plain Bushings	Anodized Aluminum	Stainless Steel 1.4104	Sintered Bronze	Nitrile Rubber

Positioning Times with LM01-37x120

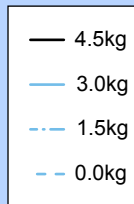
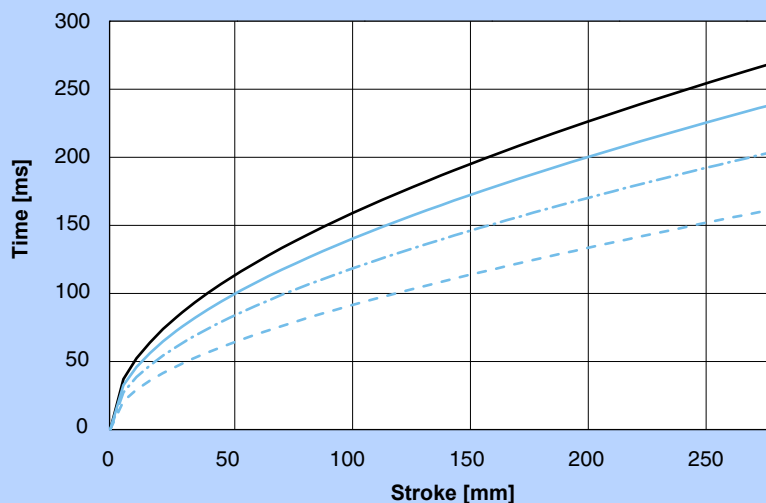

Minimum positioning times for horizontal motions with different load masses, controlled by an E1100-HC Servo Drive.

Ordering Information

LM01-37x120/80		Linear Module 37x120 with 80mm Stroke		
Linear Guide	H01-37x166/80	H01 for P01-37x120, 80mm Stroke, Ball Bearings	0150-5020	
	H01-37x166/80-GF	H01 for P01-37x120, 80mm Stroke, Plain Bushings	0150-5080	
Stator	PS01-37x120-C	Linear motor stator, connector C - IP67	0150-1223	
	PS01-37x120-C20	Linear motor stator, 0.2m Cable, connector C - IP67	0150-1237	
	PS01-37x120	Linear motor stator, 1.5m Cable, connector P	0150-1204	
Slider	PL01-20x300/220	Standard Slider for H01-37x166/80	0150-1348	

LM01-37x120/180		Linear Module 37x120 with 180mm Stroke		
Linear Guide	H01-37x166/180	H01 for P01-37x120, 180mm Stroke, Ball Bearings	0150-5021	
	H01-37x166/180-GF	H01 for P01-37x120, 180mm Stroke, Plain Bushings	0150-5081	
Stator	PS01-37x120-C	Linear motor stator, connector C - IP67	0150-1223	
	PS01-37x120-C20	Linear motor stator, 0.2m Cable, connector C - IP67	0150-1237	
	PS01-37x120	Linear motor stator, 1.5m Cable, connector P	0150-1204	
Slider	PL01-20x395/320	Standard Slider for H01-37x166/180	0150-1318	

LM01-37x120/280		Linear Module 37x120 with 280mm Stroke		
Linear Guide	H01-37x166/280	H01 for P01-37x120, 280mm Stroke, Ball Bearings	0150-5022	
	H01-37x166/280-GF	H01 for P01-37x120, 280mm Stroke, Plain Bushings	0150-5082	
Stator	PS01-37x120-C	Linear motor stator, connector C - IP67	0150-1223	
	PS01-37x120-C20	Linear motor stator, 0.2m Cable, connector C - IP67	0150-1237	
	PS01-37x120	Linear motor stator, 1.5m Cable, connector P	0150-1204	
Slider	PL01-20x500/420	Standard Slider for H01-37x166/280	0150-1328	

Accessories

Brake	HB01-37	Pneumatic Brake for H01-37/600N (4-6Bar)	0150-5052
Fan	HV01-37/48	Fan for H01-37 und -48 Linear Guides	0150-5051
MagSpring	MF01-37/H37	Mounting flange for MagSpring M01-37x...	0250-2307
	MA01-37/H37	Mounting adapter for MagSpring M01-37x...	0250-0117
Center Sleeve	HC01-09/04	Center Sleeve D9x4mm	0150-3251
Wiper	HA01-27/20-F	Wiper for H01-37 guides, front side	0150-5108

Linear module LM01-37x240

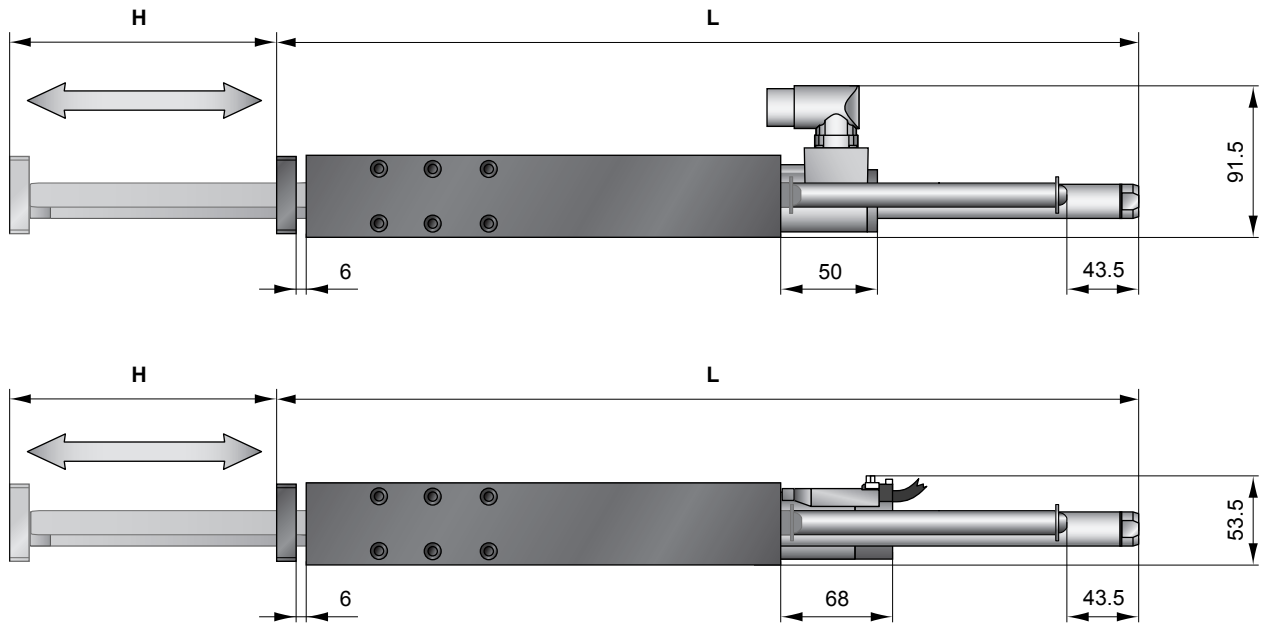

Linear Module	Bearing	Stroke H [mm (inch)]	Moving Parts L [mm (inch)]	Moving Mass ¹⁾ [g (lb)]	Total Weight ¹⁾ [g (lb)]
LM01-37x240/60	Ball Bearings	60 (2.36)	413 (16.26)	1600 (3.53)	5280 (11.63)
LM01-37x240/160	Ball Bearings	160 (6.30)	518 (20.39)	2020 (4.44)	5690 (12.54)
LM01-37x240/260	Ball Bearings	260 (10.24)	618 (24.33)	2420 (5.33)	6100 (13.43)
LM01-37x240/60-GF	Plain Bushings	60 (2.36)	413 (16.26)	1600 (3.53)	5280 (11.63)
LM01-37x240/160-GF	Plain Bushings	160 (6.30)	518 (20.39)	2020 (4.44)	5690 (12.54)
LM01-37x240/260-GF	Plain Bushings	260 (10.24)	618 (24.33)	2420 (5.33)	6100 (13.43)

¹⁾ linear guide with linear motor

Linear Guides H01-37x286

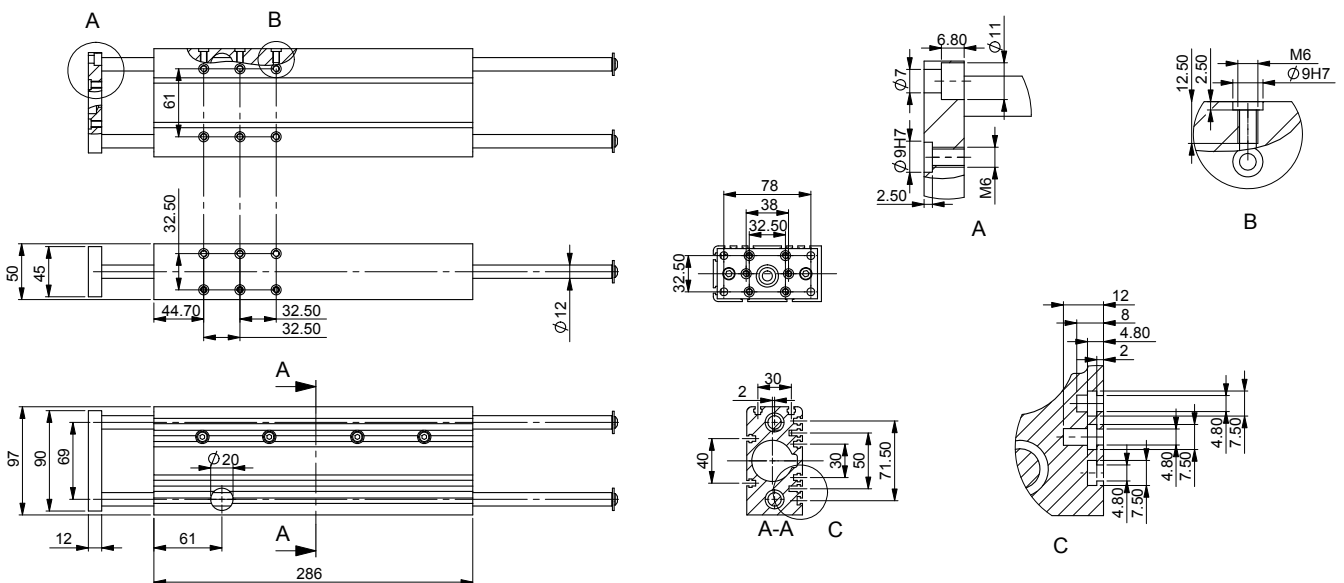

Dimensions in mm

Materials	Guide Block & Front Plate	Guide Shaft	Bearing	Wipers	
H01-37x286/...	Ball Bearings	Anodized Aluminum	Hardened Steel	Steel	Nitrile Rubber
H01-37x286/...-GF	Plain Bushings	Anodized Aluminum	Stainless Steel 1.4104	Sintered Bronze	Nitrile Rubber

Positioning Times with LM01-37x240

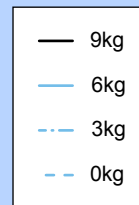
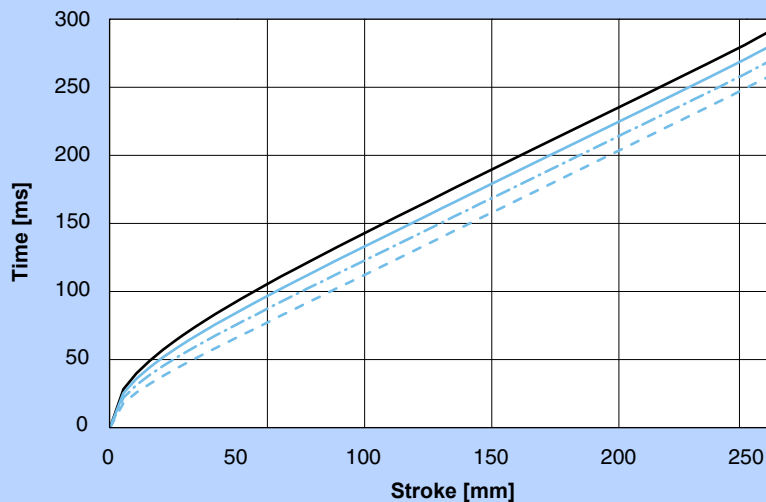

Minimum positioning times for horizontal motions with different load masses, controlled by an E1100-HC Servo Drive.

Ordering Information

LM01-37x240/60	Linear Module 37x240 with 60mm Stroke			
Linear Guide	H01-37x286/60	H01 for P01-37x240, 60mm Stroke, Ball Bearings		0150-5023
	H01-37x286/60-GF	H01 for P01-37x240, 60mm Stroke, Plain Bushings		0150-5083
Stator	PS01-37x240-C	Linear motor stator, connector C - IP67		0150-1224
	PS01-37x240F-C	Linear motor stator, connector C - IP67	Fast Winding	0150-1225
	PS01-37x240-C20	Linear motor stator, 0.2m Cable, connector C - IP67		0150-1238
	PS01-37x240F-C20	Linear motor stator, 0.2m Cable, connector C - IP67	Fast Winding	0150-1239
	PS01-37x240	Linear motor stator, 1.5m Cable, connector P		0150-1203
Slider	PL01-20x395/320	Standard Slider for H01-37x286/60		0150-1318
LM01-37x240/160	Linear Module 37x240 with 160mm Stroke			
Linear Guide	H01-37x286/160	H01 for P01-37x240, 160mm Stroke, Ball Bearings		0150-5024
	H01-37x286/160-GF	H01 for P01-37x240, 160mm Stroke, Plain Bushings		0150-5084
Stator	PS01-37x240-C	Linear motor stator, connector C - IP67		0150-1224
	PS01-37x240F-C	Linear motor stator, connector C - IP67	Fast Winding	0150-1225
	PS01-37x240-C20	Linear motor stator, 0.2m Cable, connector C - IP67		0150-1238
	PS01-37x240F-C20	Linear motor stator, 0.2m Cable, connector C - IP67	Fast Winding	0150-1239
	PS01-37x240	Linear motor stator, 1.5m Cable, connector P		0150-1203
Slider	PL01-20x500/420	Standard Slider for H01-37x286/160		0150-1328
LM01-37x240/260	Linear Module 37x240 with 260mm Stroke			
Linear Guide	H01-37x286/260	H01 for P01-37x240, 260mm Stroke, Ball Bearings		0150-5025
	H01-37x286/260-GF	H01 for P01-37x240, 260mm Stroke, Plain Bushings		0150-5085
Stator	PS01-37x240-C	Linear motor stator, connector C - IP67		0150-1224
	PS01-37x240F-C	Linear motor stator, connector C - IP67	Fast Winding	0150-1225
	PS01-37x240-C20	Linear motor stator, 0.2m Cable, connector C - IP67		0150-1238
	PS01-37x240F-C20	Linear motor stator, 0.2m Cable, connector C - IP67	Fast Winding	0150-1239
	PS01-37x240	Linear motor stator, 1.5m Cable, connector P		0150-1203
Slider	PL01-20x600/520	Standard Slider for H01-37x286/260		0150-1330
Accessories				
Brake	HB01-37	Pneumatic Brake for H01-37/600N (4-6Bar)		0150-5052
Fan	HV01-37/48	Fan for H01-37 und -48 Linear Guides		0150-5051
MagSpring	MF01-37/H37	Mounting flange for MagSpring M01-37x...		0250-2307
	MA01-37/H37	Mounting adapter for MagSpring M01-37x...		0250-0117
Center Sleeve	HC01-09/04	Center Sleeve D9x4mm		0150-3251
Wiper	HA01-27/20-F	Wiper for H01-37 guides, front side		0150-5108

Linear module LM01-48x240

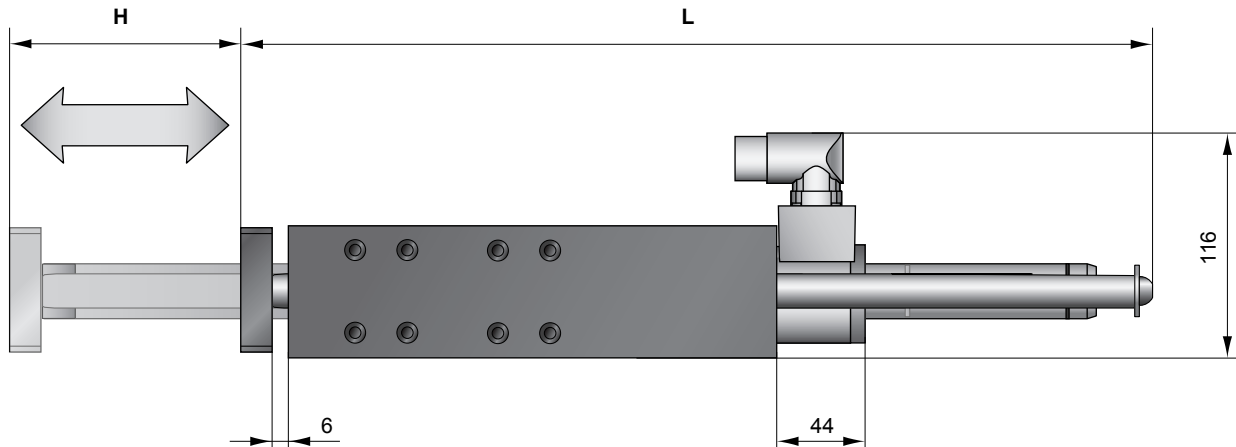

Linear Module	Bearing	Stroke H [mm (inch)]	Moving Parts L [mm (inch)]	Moving Mass ¹⁾ [g (lb)]	Total Weight ¹⁾ [g (lb)]
LM01-48X240/120	Ball Bearings	120 (4.72)	460 (18.11)	3400 (7.47)	8950 (19.66)
LM01-48X240/210	Ball Bearings	210 (8.27)	550 (21.65)	4100 (9.02)	9650 (21.21)
LM01-48X240/330	Ball Bearings	330 (12.99)	670 (26.38)	5050 (11.07)	10600 (23.26)
LM01-48X240/420	Ball Bearings	420 (16.54)	760 (29.92)	5750 (12.61)	11300 (24.80)
LM01-48X240/120-GF	Plain Bushings	120 (4.72)	460 (18.11)	3400 (7.47)	8950 (19.66)
LM01-48X240/210-GF	Plain Bushings	210 (8.27)	550 (21.65)	4100 (9.02)	9650 (21.21)
LM01-48X240/330-GF	Plain Bushings	330 (12.99)	670 (26.38)	5050 (11.07)	10600 (23.26)
LM01-48X240/420-GF	Plain Bushings	420 (16.54)	760 (29.92)	5750 (12.61)	11300 (24.80)

¹⁾ linear guide with linear motor

Linear Guides H01-48x250

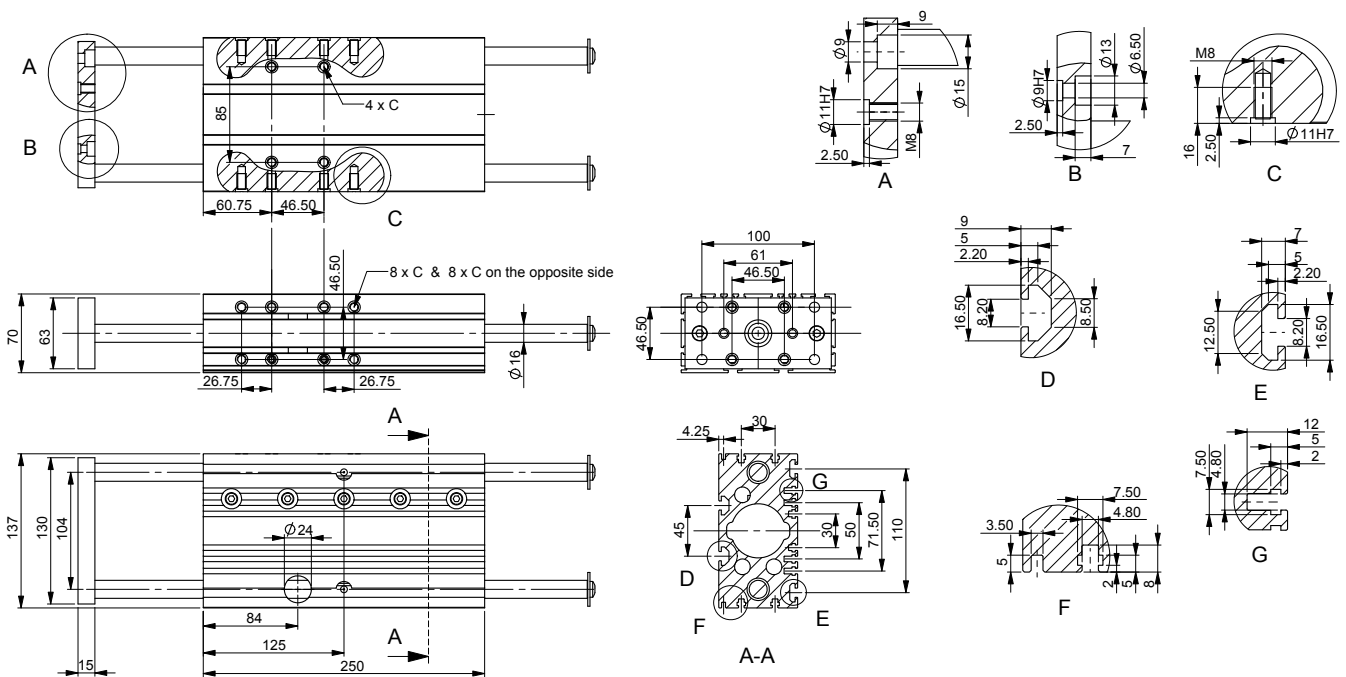

Dimensions in mm

Materials	Guide Block & Front Plate	Guide Shaft	Bearing	Wipers	
H01-48x250/...	Ball Bearings	Anodized Aluminum	Hardened Steel	Steel	Nitrile Rubber
H01-48x250/...-GF	Plain Bushings	Anodized Aluminum	Stainless Steel 1.4104	Sintered Bronze	Nitrile Rubber

Positioning Times with LM01-48x240

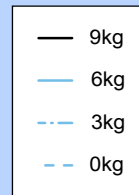
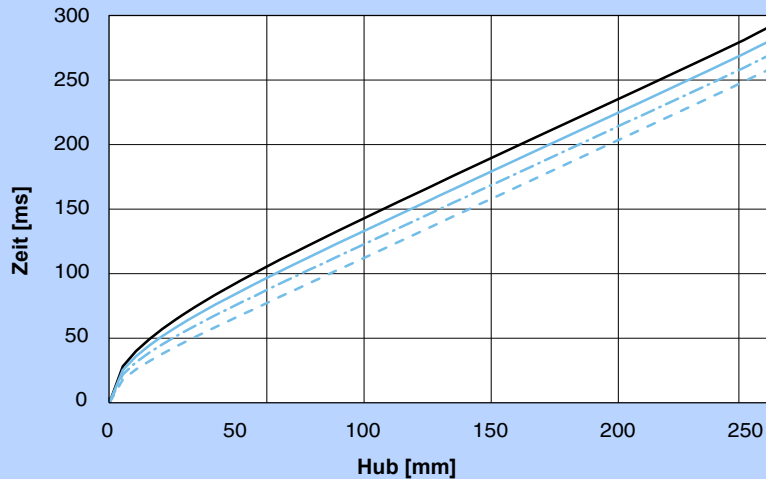

Minimum positioning times for horizontal motions with different load masses, controlled by an E1100-HC Servo Drive.

Ordering Information

LM01-48x240/120	Linear Module 48x240 with 120mm Stroke			
Linear Guide	H01-48x250/120	H01 for P01-48x240, 120mm Stroke, Ball Bearings		0150-5100
	H01-48x250/120-GF	H01 for P01-48x240, 120mm Stroke, Plain Bushings		0150-5104
Stator	PS01-48x240-C	Linear motor stator, connector C - IP67		0150-1219
	PS01-48x240F-C	Linear motor stator, connector C - IP67	Fast Winding	0150-1220
Slider	PL01-28x410/330	Standard Slider for H01-48x250/120		0150-1381
LM01-48x240/210	Linear Module 48x240 with 210mm Stroke			
Linear Guide	H01-48x250/210	H01 for P01-48x240, 210mm Stroke, Ball Bearings		0150-5101
	H01-48x250/210-GF	H01 for P01-48x240, 210mm Stroke, Plain Bushings		0150-5105
Stator	PS01-48x240-C	Linear motor stator, connector C - IP67		0150-1219
	PS01-48x240F-C	Linear motor stator, connector C - IP67	Fast Winding	0150-1220
Slider	PL01-28x500/420	Standard Slider for H01-48x250/210		0150-1382
LM01-48x240/330	Linear Module 48x240 with 330mm Stroke			
Linear Guide	H01-48x250/330	H01 for P01-48x240, 330mm Stroke, Ball Bearings		0150-5102
	H01-48x250/330-GF	H01 for P01-48x240, 330mm Stroke, Plain Bushings		0150-5106
Stator	PS01-48x240-C	Linear motor stator, connector C - IP67		0150-1219
	PS01-48x240F-C	Linear motor stator, connector C - IP67	Fast Winding	0150-1220
Slider	PL01-28x620/540	Standard Slider for H01-48x250/330		0150-1383
LM01-48x240/420	Linear Module 48x240 with 420mm Stroke			
Linear Guide	H01-48x250/420	H01 for P01-48x240, 420mm Stroke, Ball Bearings		0150-5103
	H01-48x250/420-GF	H01 for P01-48x240, 420mm Stroke, Plain Bushings		0150-5107
Stator	PS01-48x240-C	Linear motor stator, connector C - IP67		0150-1219
	PS01-48x240F-C	Linear motor stator, connector C - IP67	Fast Winding	0150-1220
Slider	PL01-28x710/630	Standard Slider for H01-48x250/420		0150-1384
Accessories				
Brake	HB01-48	Pneumatic Brake for H01-48/1000N (4-6Bar)		0150-5098
Fan	HV01-37/48	Fan for H01-37 und -48 Linear Guides		0150-5051
MagSpring	MF01-37/H37	Mounting flange for MagSpring M01-37x...		0250-2307
	MA01-37/H48	Mounting adapter for MagSpring M01-37x...		0250-0118
Sliding Block	PFN01-8/M6	Sliding Block 8mm with M6 Thread		0150-3245
Center Sleeve	HC01-11/05	Center Sleeve D11x5mm		0150-3252
Wiper	HA01-48/28-F	Wiper for H01-48 guides, front side		0150-5109

Maximum Load

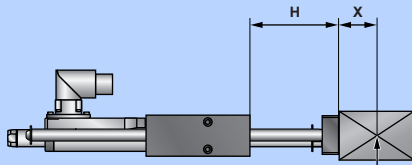

H = Stroke
 X = Distance to center of gravity
 S = Center of gravity

Cantilever extension = H + X

The maximum load depends on the cantilever extension (maximum stroke A plus distance between the center of gravity of the working load and the mounting surface).

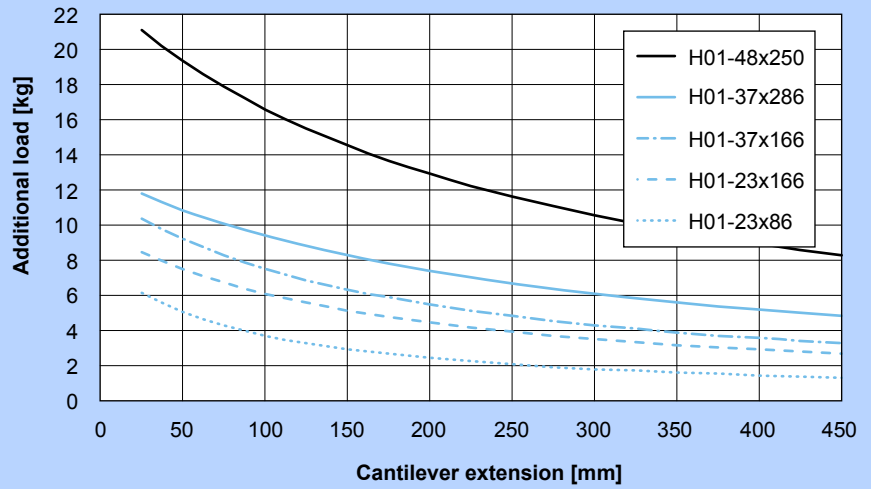

Vertical Deflection

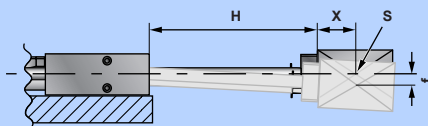

H = Stroke
 X = Distance to center of gravity
 f = Deflection of theoretical axis
 S = Center of gravity

Total deflection = static deflection + deflection under load

Deflection measured at standstill, with 10 N / 2.25 lbf load.

Deflection for smaller or larger load masses can be linearly extrapolated using the data for 10 N / 2.25 lbf.

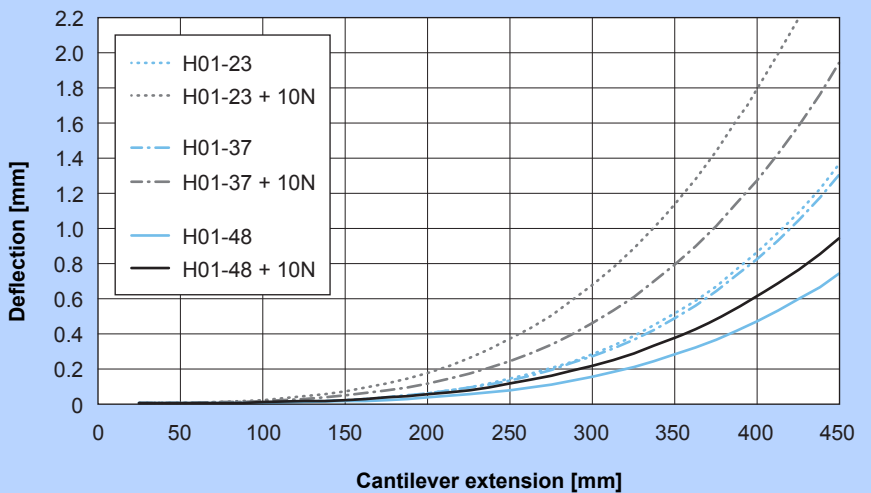

Angular Deflection

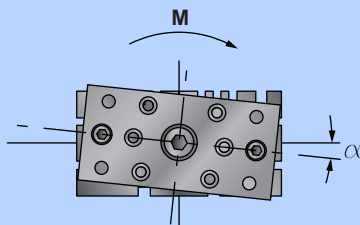

Angular deflection (twist) of the mounting plate depends on the torque load to be absorbed and the cantilever extension.

The angular deflection for smaller or larger torques can be linearly extrapolated from the deflection in the diagram.

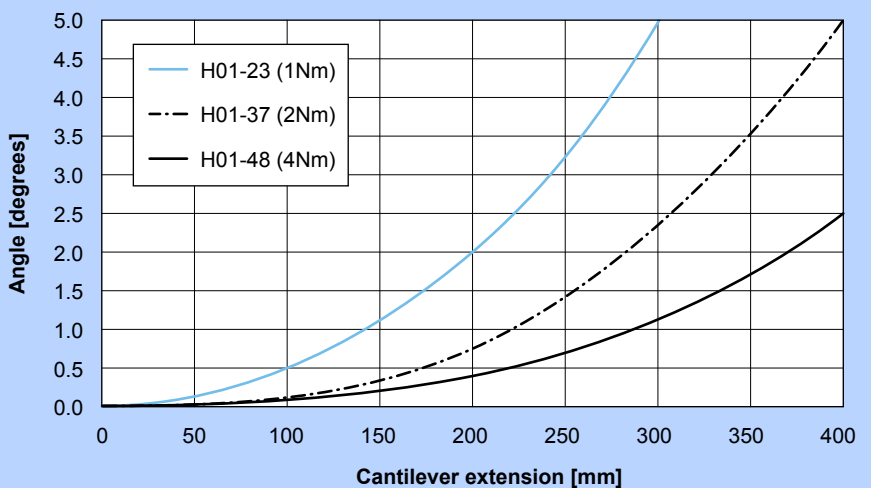

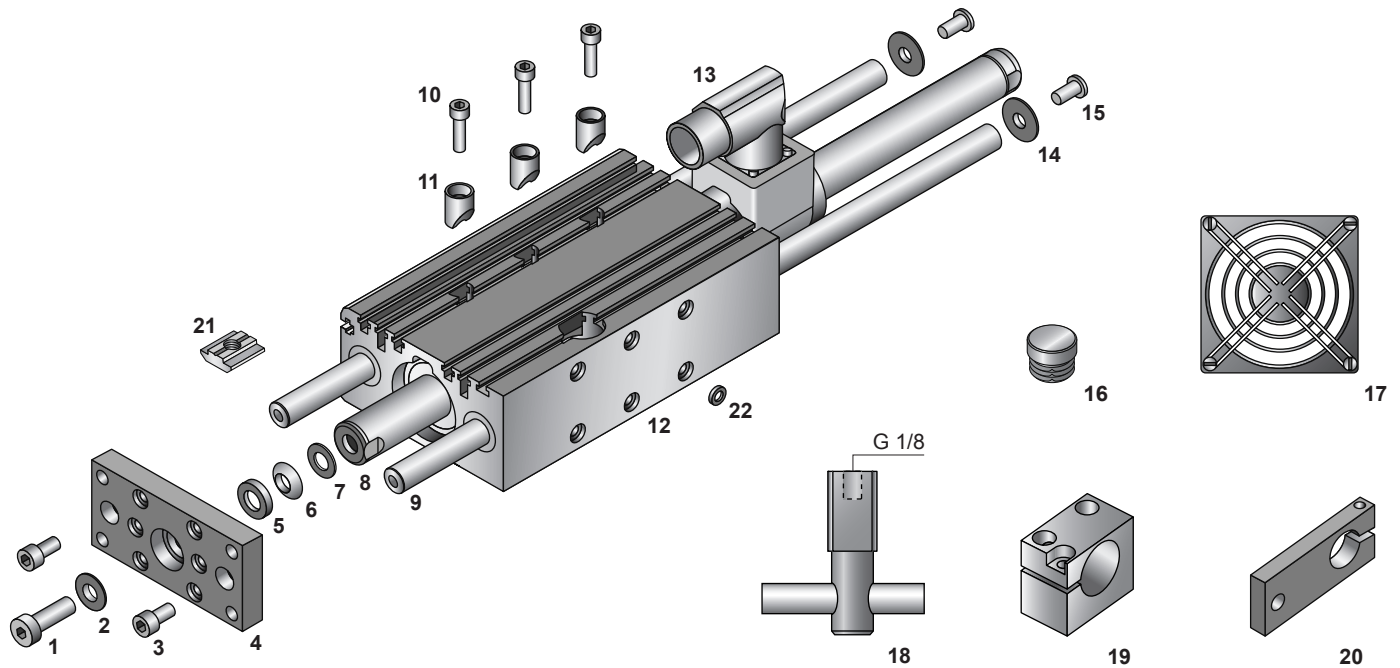

Parts List

	Linear Guide	H01-23x86	H01-23x166	H01-37x166	H01-37x286	H01-48x250
1	Slider screw	ISO 4762 M5x18	ISO 4762 M5x18	DIN7984 M8x25	DIN7984 M8x25	DIN7984 M10x35
2	Socket washer (f)	DIN 6319 c / M6	DIN 6319 c / M6	DIN 6319 c / M8	DIN 6319 c / M8	DIN 6319 c / M10
3	Shaft screw	ISO 4762 M5x12	ISO 4762 M5x12	ISO 4762 M6x12	ISO 4762 M6x12	ISO 4762 M8x20
4	Front plate	HF01-23 0150-5004	HF01-23 0150-5004	HF01-37 0150-5005	HF01-37 0150-5005	HF01-48 0150-5087
5	Ball washer (r)	DIN 6319 d / M5	DIN 6319 d / M5	DIN 6319 d / M8	DIN 6319 d / M8	DIN 6319 d / M10
6	Socket washer (r)	DIN 6319 c / M5	DIN 6319 c / M5	DIN 6319 c / M8	DIN 6319 c / M8	DIN 6319 c / M10
7	Dished washer	DIN 2093A 10/5,2/0,5	DIN 2093A 10/5,2/0,5	DIN 2093A 16/8,2/0,9	DIN 2093A 16/8,2/0,9	DIN 2093A 20/10,2/1,1
8	Slider	PL01-12x...	PL01-12x...	PL01-20x...	PL01-20x...	PL01-28x...
9	Hardened steel shafts for ball bearings	HL01-10x160 HL01-10x260 HL01-10x360	HL01-10x260 HL01-10x360 HL01-10x460	HL01-12x260 HL01-12x360 HL01-12x460	HL01-12x360 HL01-12x460 HL01-12x560	HL01-16x440 HL01-16x530 HL01-16x650 HL01-16x740
	Stainless steel shafts for plain bushings GF	HL01-10x160-GF HL01-10x260-GF HL01-10x360-GF	HL01-10x260-GF HL01-10x360-GF HL01-10x460-GF	HL01-12x260-GF HL01-12x360-GF HL01-12x460-GF	HL01-12x360-GF HL01-12x460-GF HL01-12x560-GF	HL01-16x440-GF HL01-16x530-GF HL01-16x650-GF HL01-16x740-GF
10	Clamping screw	ISO 4762 M5x18	ISO 4762 M5x18	ISO 4762 M5x18	ISO 4762 M5x18	ISO 4762 M6x25
11	Clamping cylinder	HZ01-23/37 0150-5053	HZ01-23/37 0150-5053	HZ01-23/37 0150-5053	HZ01-23/37 0150-5053	HZ01-48 0150-5086
12	Guide block with ball bearings	HS01-23x86 0150-5000	HS01-23x166 0150-5001	HS01-37x166 0150-5002	HS01-37x286 0150-5003	HS01-48x250 0150-5088
	Guide block with plain bushing GF	HS01-23x86-GF 0150-5060	HS01-23x166-GF 0150-5061	HS01-37x166-GF 0150-5062	HS01-37x286-GF 0150-5063	HS01-48x250-GF 0150-5089
13	Stator	PS01-23x80...	PS01-23x160...	PS01-37x120...	PS01-37x240...	PS01-48x240...
14	Washer	5x20/1,5	5x20/1,5	6x20/1,5	6x20/1,5	8x30/2,0
15	Shaft screw	ISO 7380 M5x12	ISO 7380 M5x12	ISO 7380 M6x12	ISO 7380 M6x12	ISO 7380 M8x16
16	Brake hole cap	-	-	HDPE 20mm	HDPE 20mm	HDPE 24mm
	Ball bearing	SKF LBBR10-LS	SKF LBBR10-LS	SKF LBBR12-LS	SKF LBBR12-LS	SKF LBBR16-LS
	Plain bushing GF	HGF01-23	HGF01-23	HGF01-37	HGF01-37	HGF01-48
Fan						
17	Set	HV01-23 0150-5050	HV01-23 0150-5050	HV01-37/48 0150-5051	HV01-37/48 0150-5051	HV01-37/48 0150-5051
Brake						
18	Pneumatic Brake	-	-	HB01-37 0150-5052	HB01-37 0150-5052	HB01-48 0150-5098
Magspring						
19	Flange	MF01-20/H23 0250-2306	MF01-20/H23 0250-2306	MF01-37/H37 0250-2307	MF01-37/H37 0250-2307	MF01-37/H37 0250-2307
20	Adapter	MA01-20/H23 0250-0116	MA01-20/H23 0250-0116	MA01-37/H37 0250-0117	MA01-37/H37 0250-0117	MA01-37/H48 0250-0118
Accessories						
21	Sliding Block	-	-	-	-	PFN01-8/M6 0150-3245
22	Center Sleeve	HC01-09/04 0150-3251	HC01-09/04 0150-3251	HC01-09/04 0150-3251	HC01-09/04 0150-3251	HC01-11/05 0150-3252
23	Wiper	-	-	HA01-37/20-F 0150-5108	HA01-37/20-F 0150-5108	HA01-48/28-F 0150-5109

Bridge Guides

Series B01 bridge guides are compact guide units with integrated ball bearings or plain bushings, for operating LinMot P01 linear motors with high-clearance sliders. The rear end plate increases the mechanical stiffness of the bridge guide.

Bridge Guides are used as load bearings, to resist external forces and rotational and bending moments, and as an anti-rotation device. They provide high-precision guidance and allow dynamic and precise positioning of the load.

The load is mounted directly to the front plate of the linear guide. Mechanical dimensions and mounting options are compatible with pneumatic linear guides. The modular design allows simple addition of accessories, such as a mechanical brake or magnetic spring, for load balancing in vertical applications.



Designation:

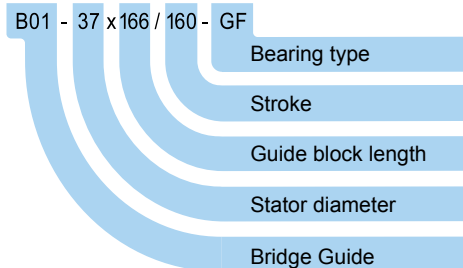

Mechanical Compatibility

LinMot B01 bridge guides are mechanically compatible with pneumatic H-guides.

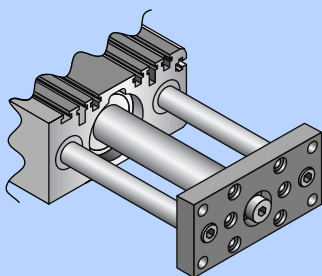

This allows simple replacement with a new drive technology, if more flexibility or higher dynamics are required.

Ball Bearings

Use of linear guides with ball bearings is recommended for standard applications under normal environmental conditions.

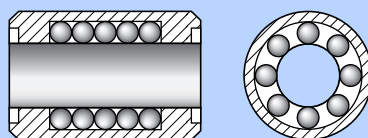

Linear guides with ball bearings have very good running characteristics, and ensure nearly frictionless operation.

Sintered Bushing

For applications in very dirty, damp, or wet environments, the use of linear guides with bushing and stainless steel shafts is recommended.

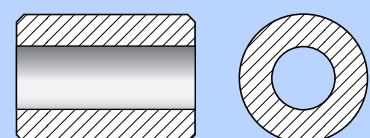

For highly dynamic applications with accelerations over 50 m/s², the use of bridge modules with Plain Bushings is also recommended.

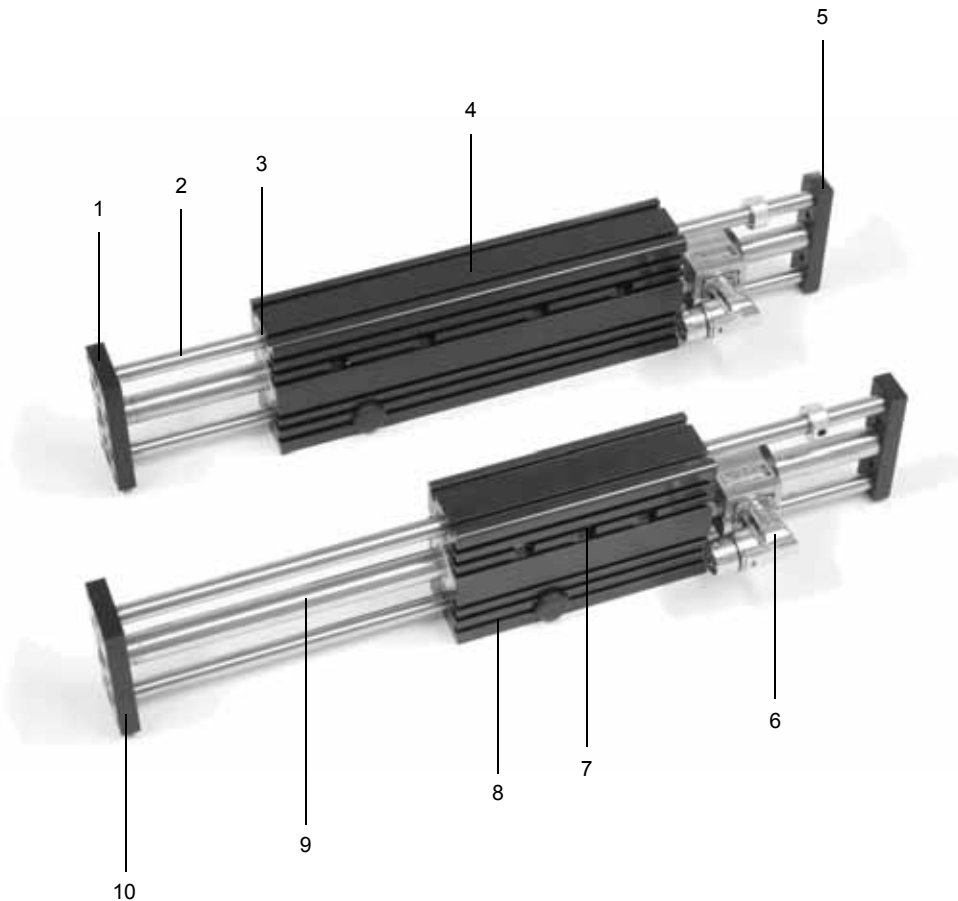

1. Mounting plate with counter bore for precise load mounting
2. Hardened or stainless steel shafts for precise positioning and quiet operation.
3. Ball bearings or plain bushings, for high load masses and long life
4. Guide block with counter bores for uncomplicated, precise mounting of the Bridge Module.
5. Mechanical end stop (rear).
6. Linear motor stator with integrated bearings, temperature and position sensors. Available with IP67 connector housing or cable exit.
7. Clamping cylinder to secure the stator in the guide block.
8. T-slots in the guide block allow simple mounting of accessories.
9. Linear motor slider, guarantees maximum force and precise positioning.
10. Integrated linear coupling for simple mounting of the slider.

Bridge Module BM01

Complete BM01 bridge modules, consisting of a B01 bridge guide and P01 linear motor, are highly dynamic design components. Compact construction and free positioning have significant advantages, especially in textile and packaging machines, assembly and feeding technology, laboratory automation, and special machines and systems.



Designation:

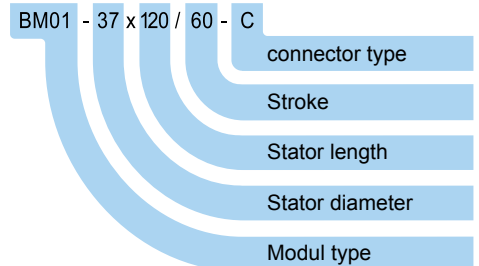

Brake Option

As an option, B01-37 (600N Holding Force) and B01-48 (1000N) guides can have a mechanical brake attached.

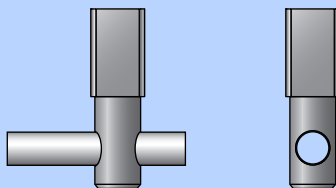

The pneumatic brake is controlled by the E1100 Servo Drive. The brake acts on the guide shafts of the linear guide, and is released under air pressure (4-6 bar). With no air pressure, the brake is on.

MagSpring Option

In vertical applications, a MagSpring can be used as a weight balancer.

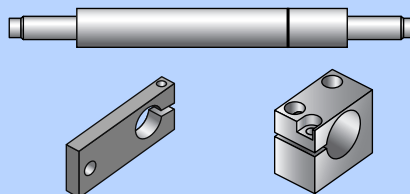

The MagSpring also prevents the linear motor from falling to the lower end stop if the linear motor is turned off or the power is lost. Appropriate accessories are available for mounting the magnetic spring.

Fan Option

With an additional fan, the holding force of the linear motor can be nearly doubled.

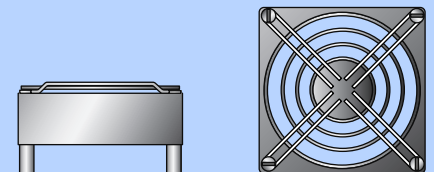

If needed, the optional fan can be mounted directly on the guide.

Bridge Module BM01-37x120

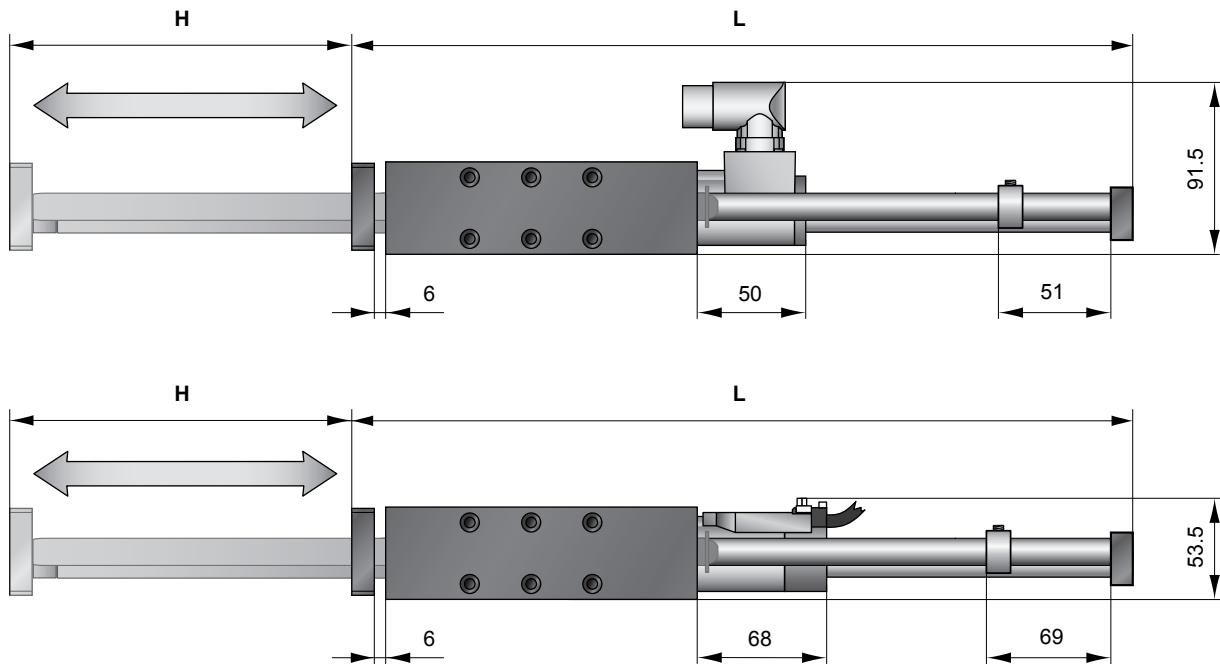

Bridge Module	Bearing	Stroke H ¹⁾ [mm (inch)]	Moving Parts L [mm (inch)]	Moving Mass ²⁾ [g (lb)]	Total Weight ²⁾ [g (lb)]
BM01-37x120/160	Ball Bearings	160 (6.30)	410 (16.14)	1450 (3.15)	3500 (7.72)
BM01-37x120/260	Ball Bearings	260 (10.24)	510 (20.08)	1820 (4.01)	3900 (8.57)
BM01-37x120/360	Ball Bearings	360 (14.17)	610 (24.02)	2210 (4.87)	4300 (9.44)
BM01-37x120/160-GF	Plain Bushings	160 (6.30)	410 (16.14)	1450 (3.15)	3500 (7.72)
BM01-37x120/260-GF	Plain Bushings	260 (10.24)	510 (20.08)	1820 (4.01)	3900 (8.57)
BM01-37x120/360-GF	Plain Bushings	360 (14.17)	610 (24.02)	2210 (4.87)	4300 (9.44)

¹⁾ The stroke is reduced by 18mm when using cable models

²⁾ bridge guide with linear motor

Bridge Guides B01-37X166

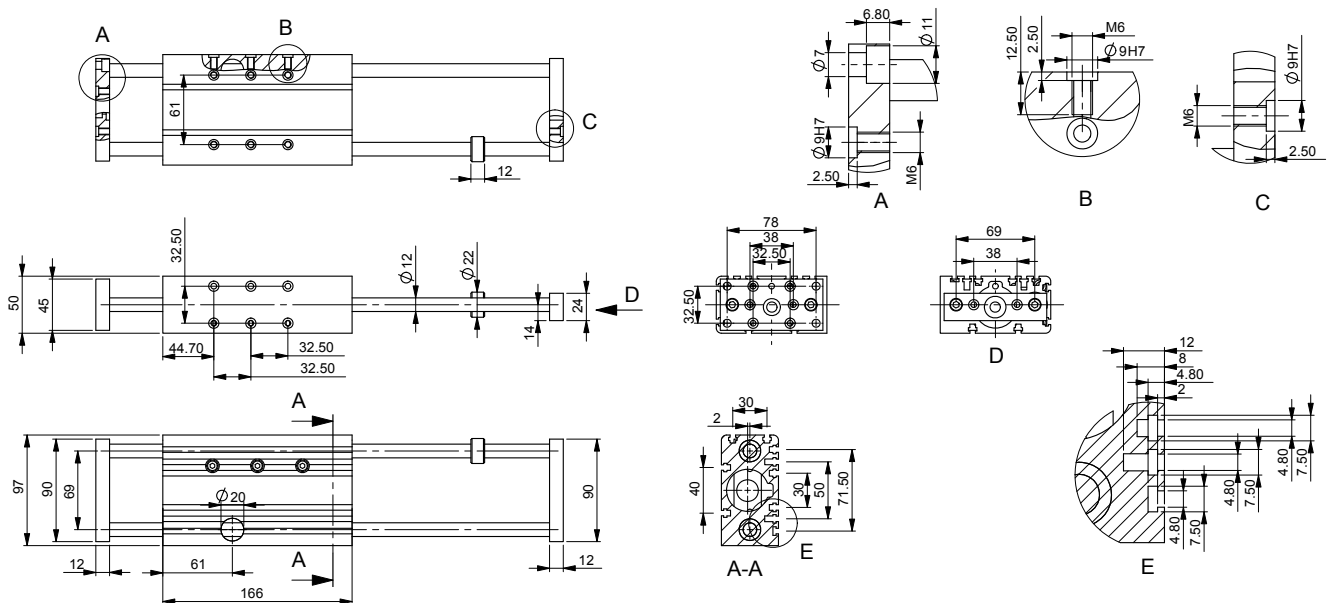

Dimensions in mm

Materials	Guide Block & Front Plate	Guide Shaft	Bearing	Wipers	
B01-37x166/...	Ball Bearings	Anodized Aluminum	Hardened Steel	Steel	Nitrile Rubber
B01-37x166/...-GF	Plain Bushings	Anodized Aluminum	Stainless Steel 1.4104	Sintered Bronze	Nitrile Rubber

Positioning Times with BM01-37x120

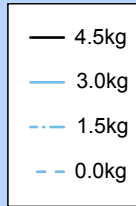
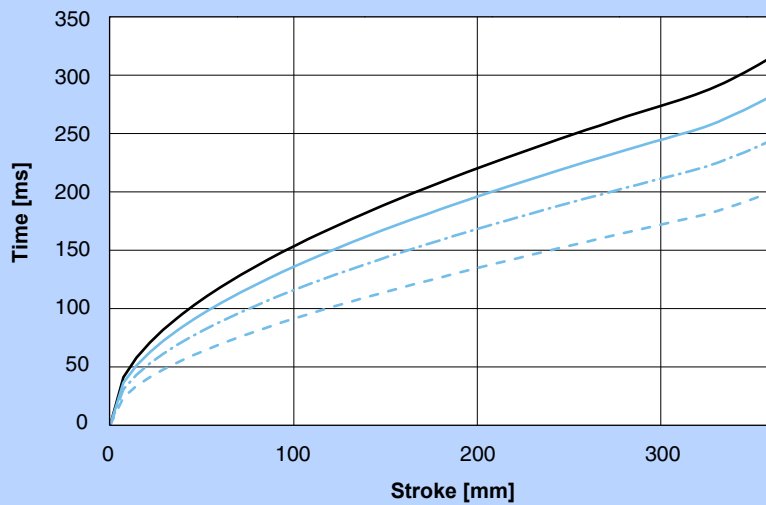

Minimum positioning times for horizontal motions with different load masses, controlled by an E1100-HC Servo Drive.

Ordering Information

BM01-37x120/160		Bridge Module 37x120 with 160mm stroke ¹⁾		
Bridge Guide	B01-37x166/160	B01 for P01-37x120, 160mm stroke, Ball Bearings		0150-5138
	B01-37x166/160-GF	B01 for P01-37x120, 160mm stroke, Plain Bushings		0150-5141
Stator	PS01-37x120-C	Linear motor stator, connector type C - IP67		0150-1223
	PS01-37x120-C20	Linear motor stator, 0.2m Cable, connector C - IP67		0150-1237
	PS01-37x120	Linear motor stator, 1.5m Cable, connector P		0150-1204
Slider	PL01-19x395/320	High clearance slider for B01-37x166/160		0150-1452

BM01-37x120/260		Bridge Module 37x120 with 260mm stroke ¹⁾		
Bridge Guide	B01-37x166/260	B01 for P01-37x120, 260mm stroke, Ball Bearings		0150-5139
	B01-37x166/260-GF	B01 for P01-37x120, 260mm stroke, Plain Bushings		0150-5142
Stator	PS01-37x120-C	Linear motor stator, connector type C - IP67		0150-1223
	PS01-37x120-C20	Linear motor stator, 0.2m Cable, connector C - IP67		0150-1237
	PS01-37x120	Linear motor stator, 1.5m Cable, connector P		0150-1204
Slider	PL01-19x500/420	High clearance slider for B01-37x166/260		0150-1455

BM01-37x120/360		Bridge Module 37x120 with 360mm stroke ¹⁾		
Bridge Guide	B01-37x166/360	B01 for P01-37x120, 360mm stroke, Ball Bearings		0150-5140
	B01-37x166/360-GF	B01 for P01-37x120, 360mm stroke, Plain Bushings		0150-5143
Stator	PS01-37x120-C	Linear motor stator, connector type C - IP67		0150-1223
	PS01-37x120-C20	Linear motor stator, 0.2m Cable, connector C - IP67		0150-1237
	PS01-37x120	Linear motor stator, 1.5m Cable, connector P		0150-1204
Slider	PL01-19x600/520	High clearance slider for B01-37x166/360		0150-1456

Accessories

Brake	HB01-37	Pneumatic Brake for B01-37 / 600N (4-6 Bar)	0150-5052
Fan	HV01-37/48	Fan for H01-37 und -48 Linear Guides	0150-5051
MagSpring	MF01-37/H37	Mounting flange for MagSpring M01-37x...	0250-2307
	MA01-37/H37	Mounting adapter for MagSpring M01-37x...	0250-0117
Center Sleeve	HC01-09/04	Center Sleeve D9x4mm	0150-3251
Wiper	HA01-37/19-F	Wiper for B01-37 guides, front side	0150-5177

¹⁾ The stroke is reduced by 18mm when using cable models

Bridge Module BM01-37x240

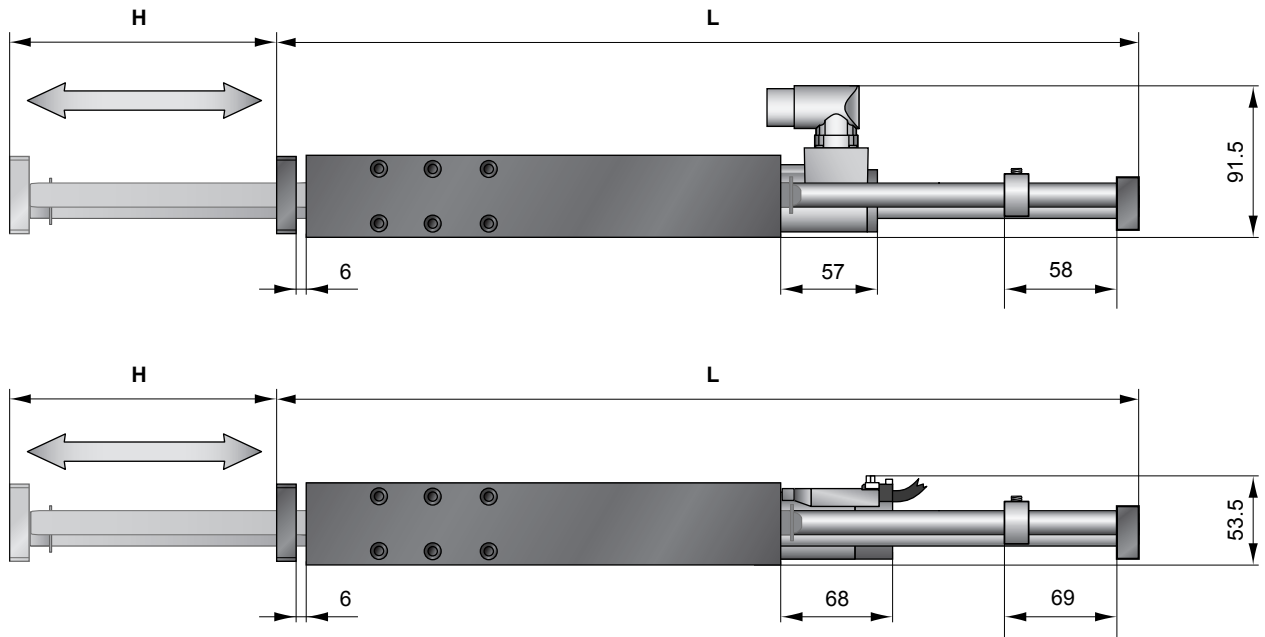

Bridge Module	Bearing	Stroke H ¹⁾ [mm (inch)]	Moving Parts L [mm (inch)]	Moving Mass ²⁾ [g (lb)]	Total Weight ²⁾ [g (lb)]
BM01-37x240/140	Ball Bearings	140 (5.51)	510 (20.08)	1820 (4.01)	5500 (12.11)
BM01-37x240/240	Ball Bearings	240 (9.45)	610 (24.02)	2210 (4.87)	5900 (12.97)
BM01-37x240/340	Ball Bearings	340 (13.39)	710 (27.95)	2600 (5.71)	6300 (13.81)
BM01-37x240/140-GF	Plain Bushings	140 (5.51)	510 (20.08)	1820 (4.01)	5500 (12.11)
BM01-37x240/240-GF	Plain Bushings	240 (9.45)	610 (24.02)	2210 (4.87)	5900 (12.97)
BM01-37x240/340-GF	Plain Bushings	340 (13.39)	710 (27.95)	2600 (5.71)	6300 (13.81)

¹⁾ The stroke is reduced by 18mm when using cable models

²⁾ bridge guide with linear motor

Bridge Guides B01-37x286

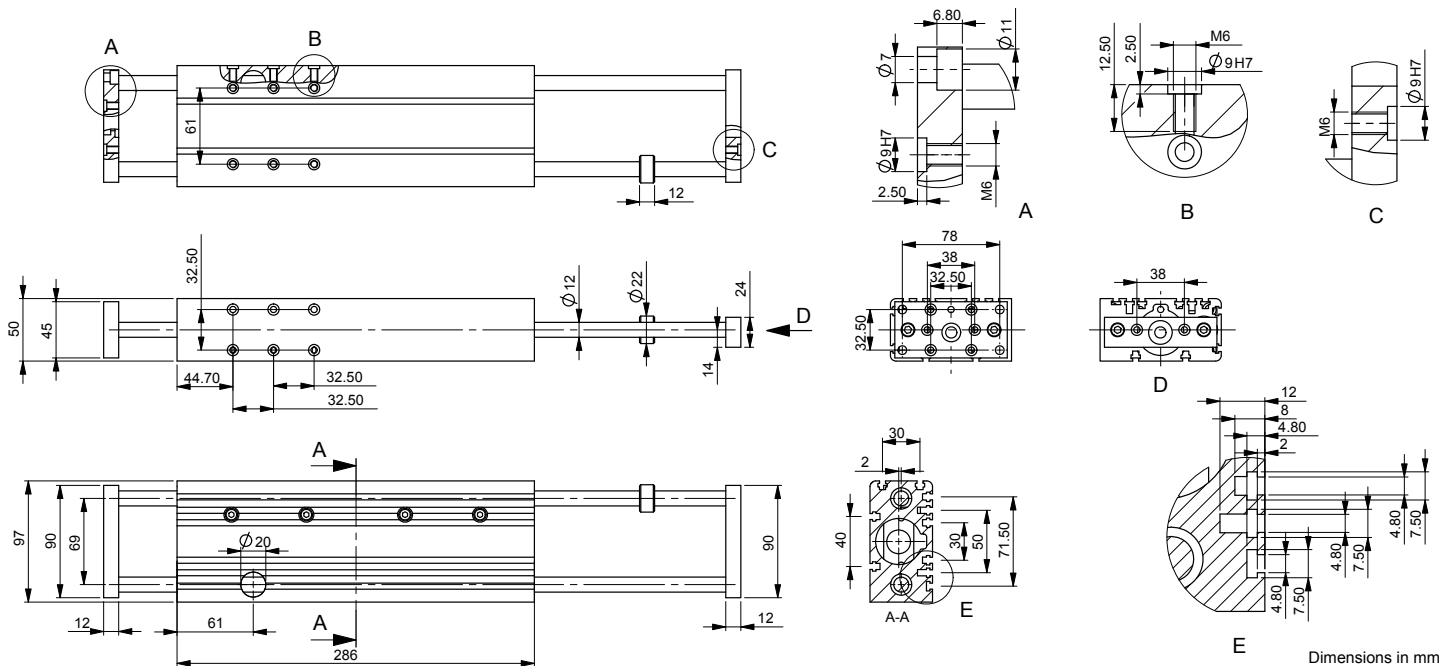

Dimensions in mm

Materials	Guide Block & Front Plate	Guide Shaft	Bearing	Wipers	
B01-37x286/...	Ball Bearings	Anodized Aluminum	Hardened Steel	Steel	Nitrile Rubber
B01-37x286/...-GF	Plain Bushings	Anodized Aluminum	Stainless Steel 1.4104	Sintered Bronze	Nitrile Rubber

Positioning Times with BM01-37x240

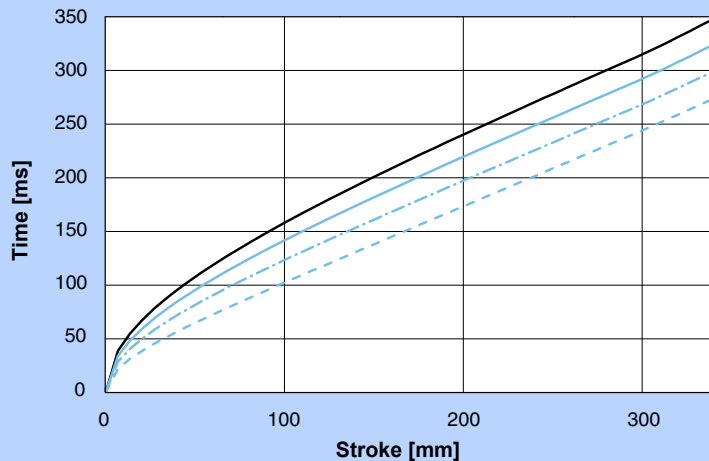

Minimum positioning times for horizontal motions with different load masses, controlled by an E1100-HC Servo Drive.

Ordering Information

BM01-37x240/140		Bridge Module 37x240 with 140mm stroke ¹⁾		
Bridge Guide	B01-37x286/140	B01 for P01-37x240, 140mm stroke, Ball Bearings		0150-5144
	B01-37x286/140-GF	B01 for P01-37x240, 140mm stroke, Plain Bushings		0150-5147
Stator	PS01-37x240-C	Linear motor stator, connector type C - IP67		0150-1224
	PS01-37x240F-C	Linear motor stator, connector type C - IP67	Fast Winding	0150-1225
	PS01-37x240-C20	Linear motor stator, 0.2m Cable, connector C - IP67		0150-1238
	PS01-37x240F-C20	Linear motor stator, 0.2m Cable, connector C - IP67	Fast Winding	0150-1239
	PS01-37x240	Linear motor stator, 1.5m Cable, connector P		0150-1203
Slider	PL01-19x500/420	High clearance slider B01-37x286/140		0150-1455

BM01-37x240/240		Bridge Module 37x240 with 240mm stroke ¹⁾		
Bridge Guide	B01-37x286/240	B01 for P01-37x240, 240mm stroke, Ball Bearings		0150-5145
	B01-37x286/240-GF	B01 for P01-37x240, 240mm stroke, Plain Bushings		0150-5148
Stator	PS01-37x240-C	Linear motor stator, connector type C - IP67		0150-1224
	PS01-37x240F-C	Linear motor stator, connector type C - IP67	Fast Winding	0150-1225
	PS01-37x240-C20	Linear motor stator, 0.2m Cable, connector C - IP67		0150-1238
	PS01-37x240F-C20	Linear motor stator, 0.2m Cable, connector C - IP67	Fast Winding	0150-1239
	PS01-37x240	Linear motor stator, 1.5m Cable, connector P		0150-1203
Slider	PL01-19x600/520	High clearance slider B01-37x286/240		0150-1456

BM01-37x240/340		Bridge Module 37x240 with 340mm stroke ¹⁾		
Bridge Guide	B01-37x286/340	B01 for P01-37x240, 340mm stroke, Ball Bearings		0150-5146
	B01-37x286/340-GF	B01 for P01-37x240, 340mm stroke, Plain Bushings		0150-5149
Stator	PS01-37x240-C	Linear motor stator, connector type C - IP67		0150-1224
	PS01-37x240F-C	Linear motor stator, connector type C - IP67	Fast Winding	0150-1225
	PS01-37x240-C20	Linear motor stator, 0.2m Cable, connector C - IP67		0150-1238
	PS01-37x240F-C20	Linear motor stator, 0.2m Cable, connector C - IP67	Fast Winding	0150-1239
	PS01-37x240	Linear motor stator, 1.5m Cable, connector P		0150-1203
Slider	PL01-19x700/620	High clearance slider for B01-37x286/340		0150-1457

Accessories

Brake	HB01-37	Pneumatic Brake for B01-37 / 600N (4-6 Bar)		0150-5052
Fan	HV01-37/48	Fan for H01-37 und -48 Linear Guides		0150-5051
MagSpring	MF01-37/H37	Mounting flange for MagSpring M01-37x...		0250-2307
	MA01-37/H37	Mounting adapter for MagSpring M01-37x...		0250-0117
Center Sleeve	HC01-09/04	Center Sleeve D9x4mm		0150-3251
Wiper	HA01-37/19-F	Wiper for B01-37 guides, front side		0150-5177

¹⁾ The stroke is reduced by 18mm when using cable models

Bridge Module BM01-48x240

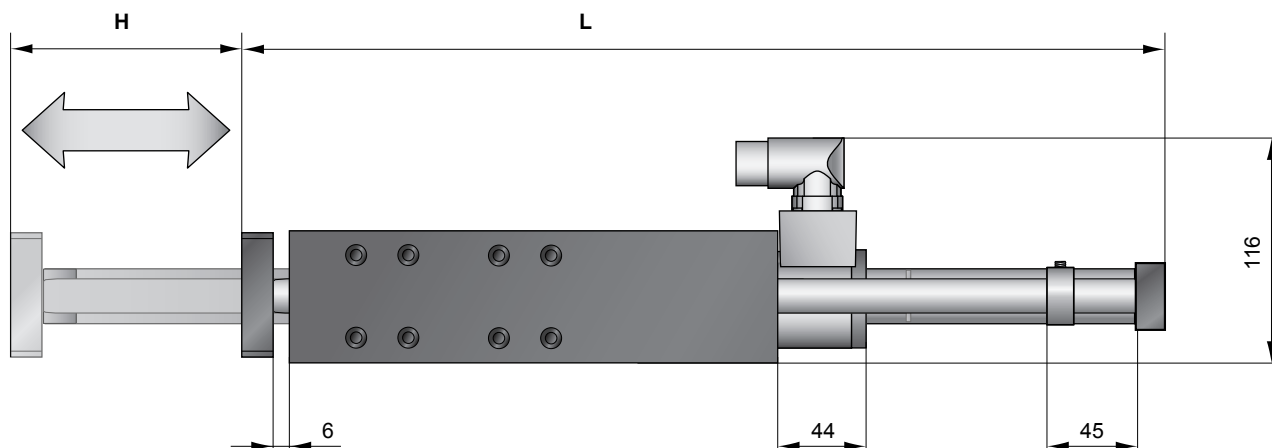

Bridge Module	Bearing	Stroke H [mm (inch)]	Moving Parts L [mm (inch)]	Moving Mass ¹⁾ [g (lb)]	Total Weight ¹⁾ [g (lb)]
BM01-48X240/90	Ball Bearings	90 (3.54)	423 (16.65)	3350 (7.39)	8900 (19.58)
BM01-48X240/180	Ball Bearings	180 (7.09)	513 (20.20)	4020 (8.86)	9600 (21.05)
BM01-48X240/300	Ball Bearings	300 (11.81)	633 (24.92)	4950 (10.82)	10500 (23.02)
BM01-48X240/390	Ball Bearings	390 (15.35)	723 (28.46)	5600 (12.32)	11200 (24.51)
BM01-48X240/90-GF	Plain Bushings	90 (3.54)	423 (16.65)	3350 (7.39)	8900 (19.58)
BM01-48X240/180-GF	Plain Bushings	180 (7.09)	513 (20.20)	4020 (8.86)	9600 (21.05)
BM01-48X240/300-GF	Plain Bushings	300 (11.81)	633 (24.92)	4950 (10.82)	10500 (23.02)
BM01-48X240/390-GF	Plain Bushings	390 (15.35)	723 (28.46)	5600 (12.32)	11200 (24.51)

¹⁾ bridge guide with linear motor

Bridge Guides B01-48x250

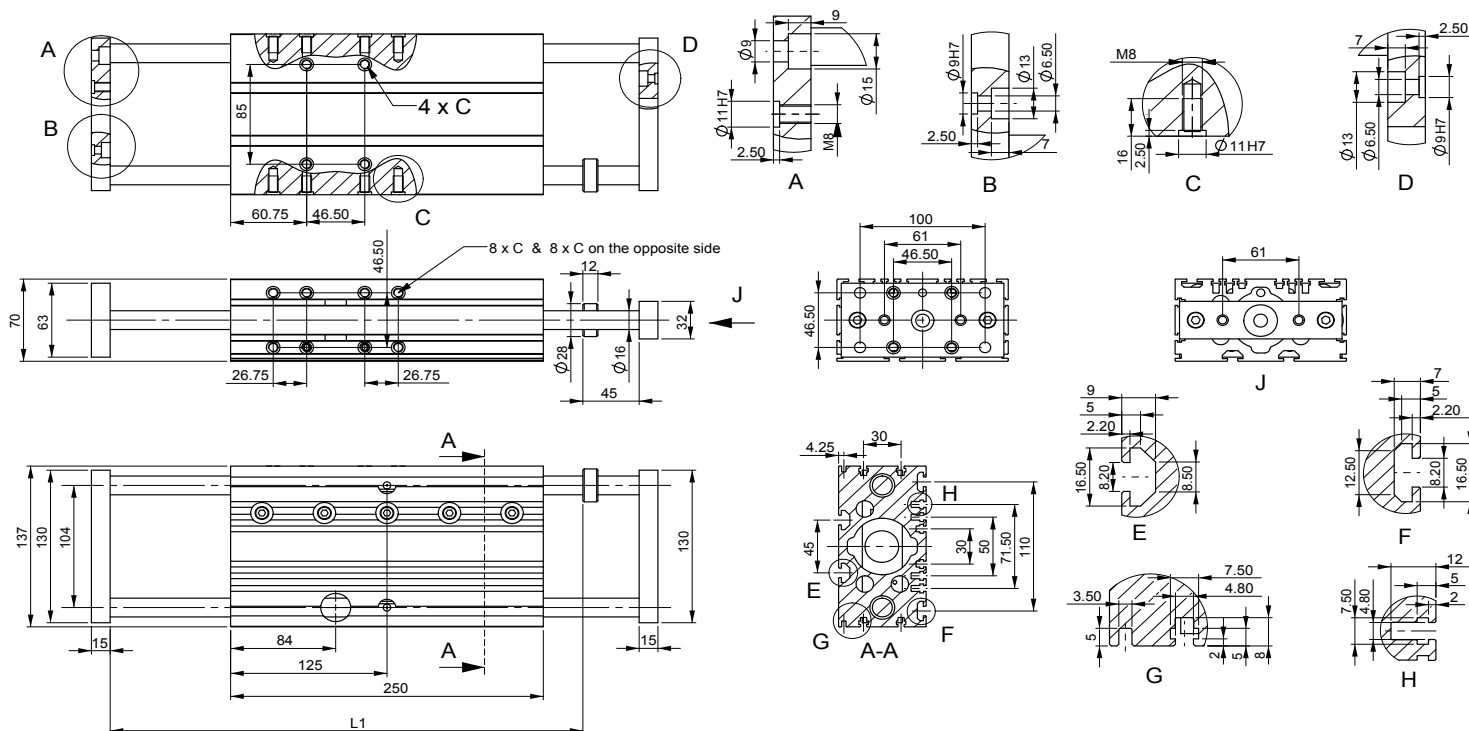

Dimensions in mm

Materials	Guide Block & Front Plate	Guide Shaft	Bearing	Wipers	
B01-48x250/...	Ball Bearings	Anodized Aluminum	Hardened Steel	Steel	Nitrile Rubber
B01-48x250/...-GF	Plain Bushings	Anodized Aluminum	Stainless Steel 1.4104	Sintered Bronze	Nitrile Rubber

Positioning Times with BM01-48x240

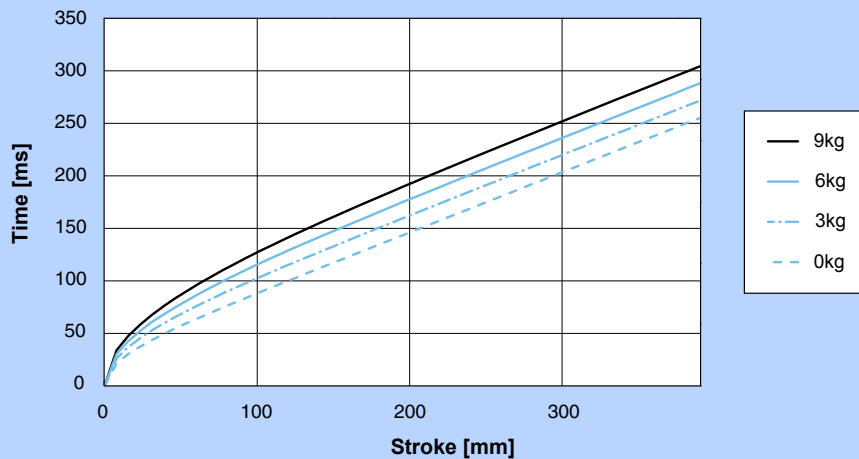

Minimum positioning times for horizontal motions with different load masses, controlled by an E1100-HC Servo Drive.

Ordering Information

BM01-48x240/90		Bridge Module 48x240 with 90mm stroke			
Bridge Guide	B01-48x250/90	B01 for P01-48x240, 90mm stroke, Ball Bearings		0150-5150	
	B01-48x250/90-GF	B01 for P01-48x240, 90mm stroke, Plain Bushings		0150-5154	
Stator	PS01-48x240-C	Linear motor stator, connector type C - IP67		0150-1219	
	PS01-48x240F-C	Linear motor stator, connector type C - IP67		Fast Winding 0150-1220	
Slider	PL01-27x410/330	High clearance slider for B01-48x250/90		0150-1468	
BM01-48x240/180		Bridge Module 48x240 with 180mm stroke			
Bridge Guide	B01-48x250/180	B01 for P01-48x240, 180mm stroke, Ball Bearings		0150-5151	
	B01-48x250/180-GF	B01 for P01-48x240, 180mm stroke, Plain Bushings		0150-5155	
Stator	PS01-48x240-C	Linear motor stator, connector type C - IP67		0150-1219	
	PS01-48x240F-C	Linear motor stator, connector type C - IP67		Fast Winding 0150-1220	
Slider	PL01-27x500/420	High clearance slider for B01-48x250/180		0150-1469	
BM01-48x240/300		Bridge Module 48x240 with 300mm stroke			
Bridge Guide	B01-48x250/300	B01 for P01-48x240, 300mm stroke, Ball Bearings		0150-5152	
	B01-48x250/300-GF	B01 for P01-48x240, 300mm stroke, Plain Bushings		0150-5156	
Stator	PS01-48x240-C	Linear motor stator, connector type C - IP67		0150-1219	
	PS01-48x240F-C	Linear motor stator, connector type C - IP67		Fast Winding 0150-1220	
Slider	PL01-27x620/540	High clearance slider for B01-48x250/300		0150-1470	
BM01-48x240/390		Bridge Module 48x240 with 390mm stroke			
Bridge Guide	B01-48x250/390	B01 for P01-48x240, 390mm stroke, Ball Bearings		0150-5153	
	B01-48x250/390-GF	B01 for P01-48x240, 390mm stroke, Plain Bushings		0150-5157	
Stator	PS01-48x240-C	Linear motor stator, connector type C - IP67		0150-1219	
	PS01-48x240F-C	Linear motor stator, connector type C - IP67		Fast Winding 0150-1220	
Slider	PL01-27x710/630	High clearance slider for B01-48x250/390		0150-1471	

Accessories

Brake	HB01-48	Pneumatic Brake for B01-48 / 1000N (4-6 Bar)	0150-5098
Fan	HV01-37/48	Fan for B01-37 and -48 bridge guides	0150-5051
MagSpring	MF01-37/H37	Mounting flange for MagSpring M01-37x...	0250-2307
	MA01-37/H48	Mounting adapter for MagSpring M01-37x...	0250-0118
Sliding Block	PFN01-8/M6	Sliding Block 8mm with M6 Thread	0150-3245
Center Sleeve	HC01-11/05	Center Sleeve D11x5mm	0150-3252
Wiper	HA01-48/27-F	Wiper for B01-48 guides, front side	0150-5178

Maximum Load

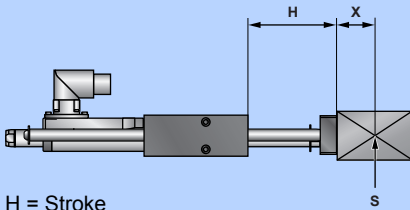

H = Stroke
 X = Distance to center of gravity
 S = Center of gravity

Cantilever extension = H + X

The maximum load depends on the cantilever extension (maximum stroke A plus distance between the center of gravity of the working load and the mounting surface).

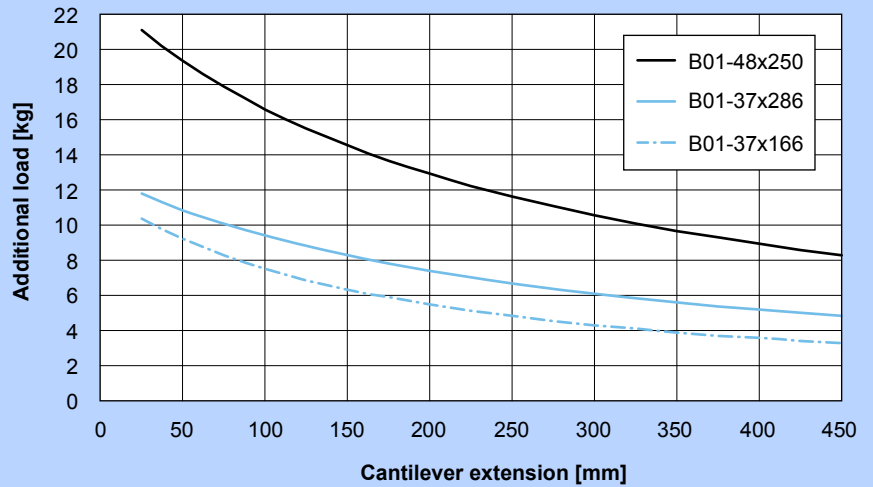

Vertical Deflection

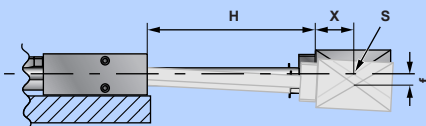

H = Stroke
 X = Distance to center of gravity
 f = Deflection of theoretical axis
 S = Center of gravity

Total deflection = static deflection + deflection under load

Deflection measured at standstill, with 10 N / 2.25 lbf load.

Deflection for smaller or larger load masses can be linearly extrapolated using the data for 10 N / 2.25 lbf.

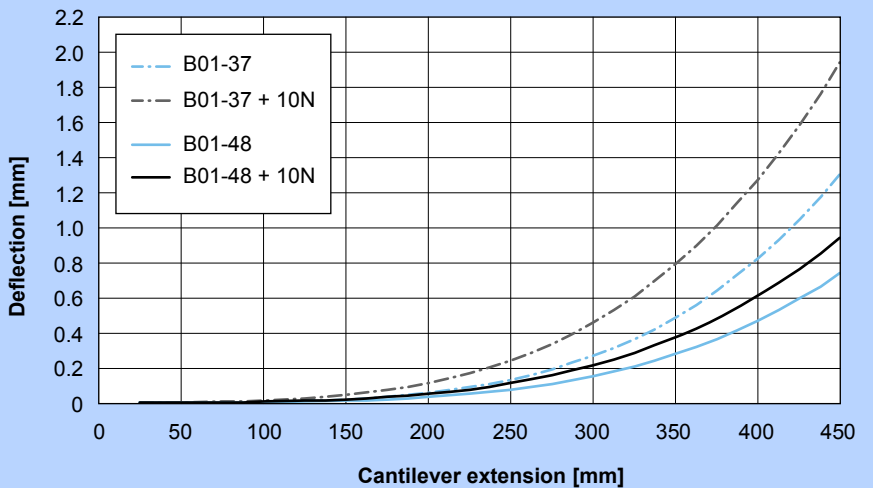

Angular Deflection

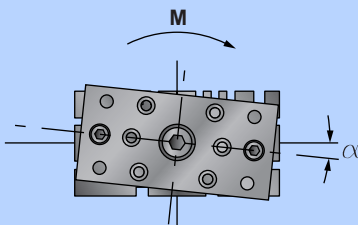

Angular deflection (twist) of the mounting plate depends on the torque load to be absorbed and the cantilever extension.

The angular deflection for smaller or larger torques can be linearly extrapolated from the deflection in the diagram.

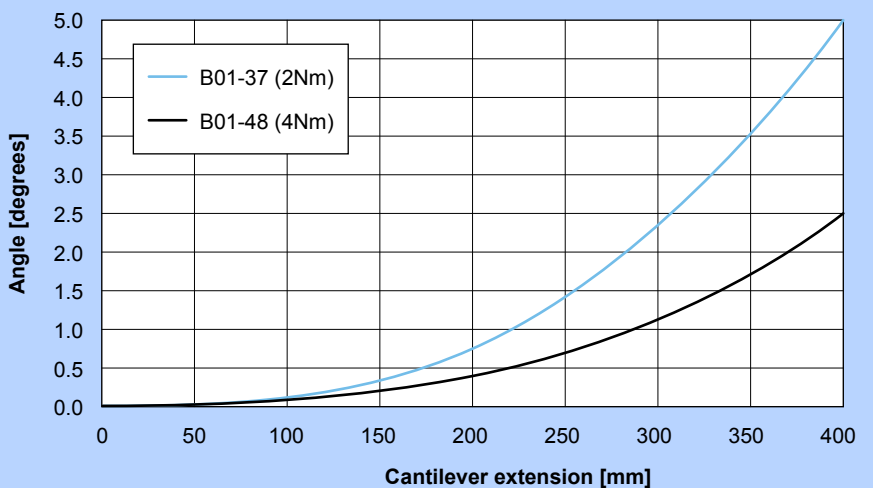

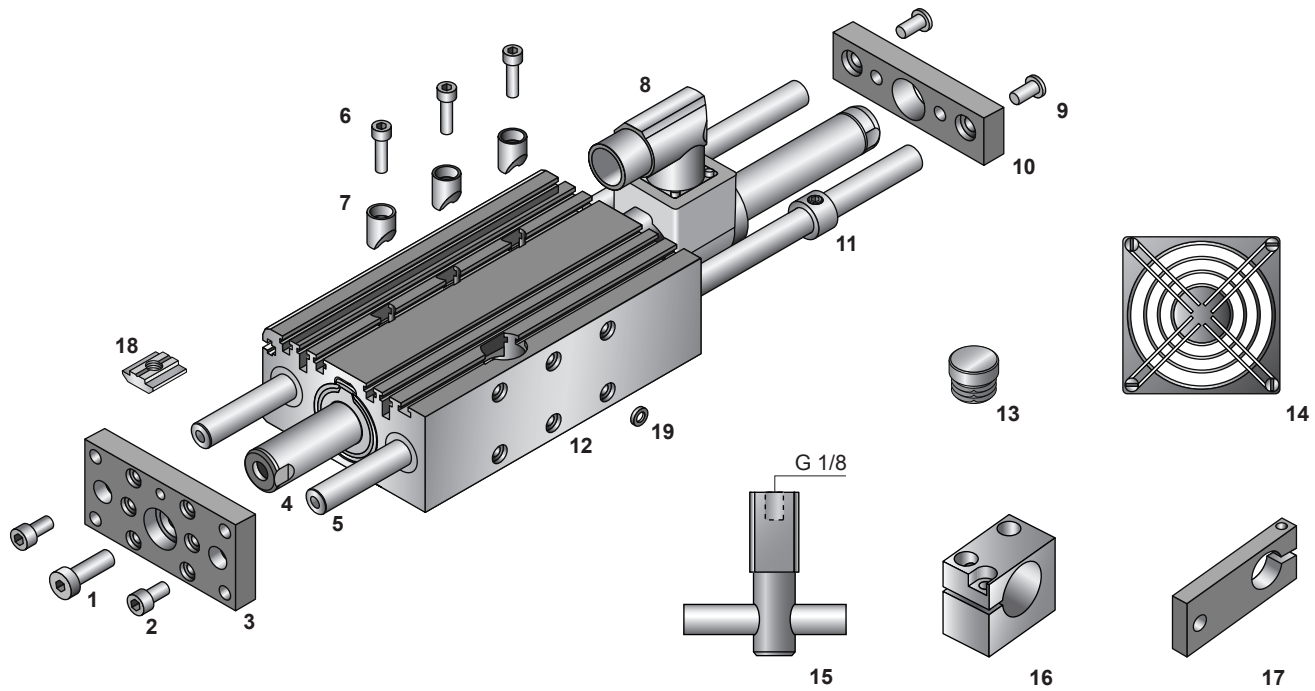

Parts List				
	Bridge Guide	B01-37x166	B01-37x286	B01-48x250
1	Slider screw	ISO 4762 M5x18	DIN7984 M8x25	DIN7984 M10x35
2	Shaft screw	ISO 4762 M6x12	ISO 4762 M6x12	ISO 4762 M8x20
3	Front plate	BF01-37 0150-5112	BF01-37 0150-5112	BF01-48 0150-5110
4	Slider	PL01-19x...	PL01-19x...	PL01-27x...
5	Hardened steel shafts for ball bearings	HL01-12x390 HL01-12x490 HL01-12x590	HL01-12x490 HL01-12x590 HL01-12x690	HL01-16x397 HL01-16x487 HL01-16x607 HL01-16x697
	Stainless steel shafts for plain bushings GF	HL01-12x390-GF HL01-12x490-GF HL01-12x590-GF	HL01-12x490-GF HL01-12x590-GF HL01-12x690-GF	HL01-16x397-GF HL01-16x487-GF HL01-16x607-GF HL01-16x697-GF
6	Clamping screw	ISO 4762 M5x18	ISO 4762 M5x18	ISO 4762 M6x25
7	Clamping cylinder	HZ01-23/37 0150-5053	HZ01-23/37 0150-5053	HZ01-48 0150-5086
8	Stator	PS01-37x120...	PS01-37x240...	PS01-48x240...
9	Shaft screw	ISO 4762 M6x12	ISO 4762 M6x12	ISO 4762 M8x20
10	Front plate	BR01-37 0150-5113	BR01-37 0150-5113	BR01-48 0150-5111
11	Rear end stop			
12	Guide block with ball bearings	HS01-37x166 0150-5002	HS01-37x286 0150-5003	HS01-48x250 0150-5088
	Guide block with plain bushings GF	HS01-37x166-GF 0150-5062	HS01-37x286-GF 0150-5063	HS01-48x250-GF 0150-5089
13	Brake hole cap	HDPE 20mm	HDPE 20mm	HDPE 24mm
	Ball bearing	SKF LBBR12-LS	SKF LBBR12-LS	SKF LBBR12-LS
	Plain bushings GF	HGF01-37	HGF01-37	HGF01-48
Fan				
14	Set	HV01-37/48 0150-5051	HV01-37/48 0150-5051	HV01-37/48 0150-5051
Brake				
15	Pneumatic brake	HB01-37 0150-5052	HB01-37 0150-5052	HB01-48 0150-5098
Magspring				
16	Flange	MF01-37/H37 0250-2307	MF01-37/H37 0250-2307	MF01-37/H37 0250-2307
17	Adapter	MA01-37/H37 0250-0117	MA01-37/H37 0250-0117	MA01-37/H48 0250-0118
Accessories				
18	Sliding Block	-	-	PFN01-8/M6 0150-3245
19	Center Sleeve	HC01-09/04 0150-3251	HC01-09/04 0150-3251	HC01-11/05 0150-3252
20	Wiper	HA01-37/19-F 0150-5177	HA01-37/19-F 0150-5177	HA01-48/27-F 0150-5178



Motor Cables 508

Motor Flanges 518

Slider Mounts 522

Wipers 524

External Position Sensor 526

Switched-Mode Power Supplies 528

Switched-Mode Power Supplies 72V 530

Transformer Supplies 532

Regeneration Resistor 534

Connector Cable and Converter 534

Control Box 535

Motor Accessories

An extensive array of accessories, tailored to LinMot P01 linear motors and compatible with the Servo Drives, rounds out the LinMot Drive Systems product range.



Motor Cable

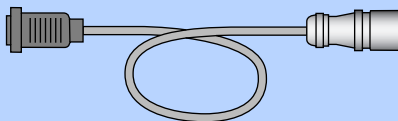

Pre-fabricated motor cables, or bulk stock in standard, high-flex, and robot versions.

Details Page 508

Motor Flanges

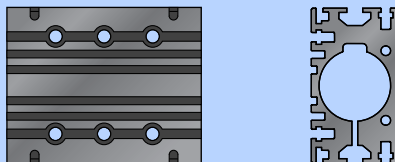

Motor flanges for mounting LinMot stators.

Details Page 518

Slider Mounting Kits

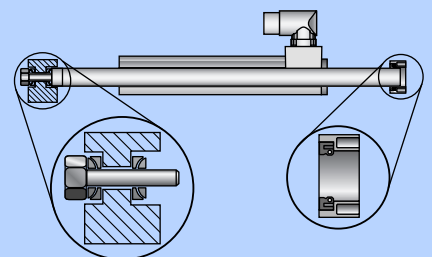

Slider mounting kits, for simple mounting of the slider in "moving slider" or "moving stator" applications.

Details Page 522

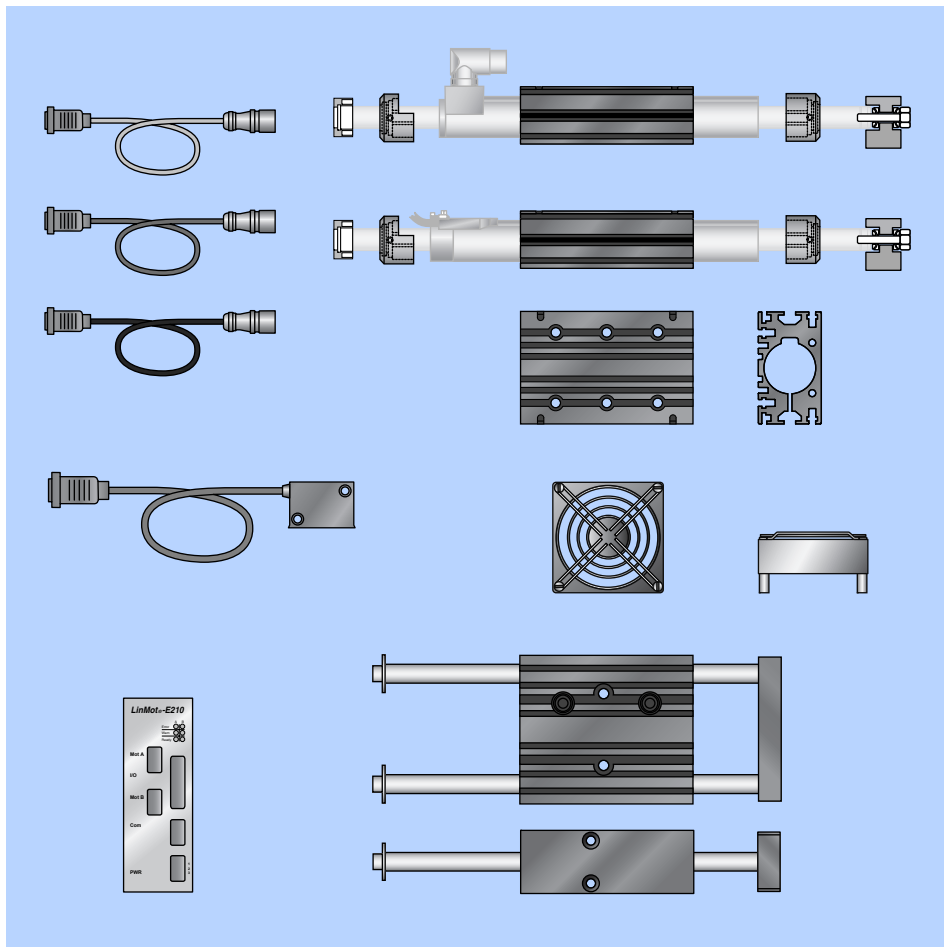

LinMot's array of accessories designed for linear motors allows quick, simple implementation and startup of various tasks. The original motor accessories, specially designed for LinMot, also ensure reliable and fault-free operation of the linear motors.

Option: Fan

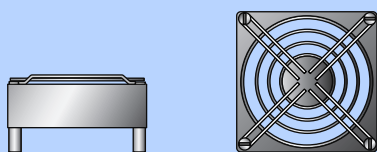

With an optional fan, the effective force of the linear motor can be nearly doubled.

Details Page 521

Option: Wipers

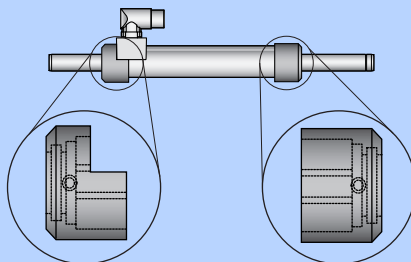

Wipers for use in difficult environments. The wipers keep the slider free of grease or contaminants, and protect the stator from dirt.

Details Page 524

Option: External Position Sensor

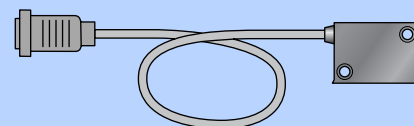

An external position sensor is available for high-precision applications with extreme requirements for positioning accuracy.

Details Page 526

Motor Cables

Motor cables are available for linear motors with the designation K, KS, and KR for stationary installation, installation in cable chains, and for robot applications.

LinMot motor cables are available in all three versions as bulk goods, as a roll, or as a completely fabricated motor cable with a wide range of plug combinations and any desired length. Standard lengths with the most common connector combinations are also available from stock.



Standard Motor Cable K



The standard motor cable, type K, is suitable for stationary runs. It is used wherever the motor cable is fixed and is not subject to motion. At exposed locations, the motor cable should be protected from mechanical damage by cable conduits.

High-Flex Motor Cable KS

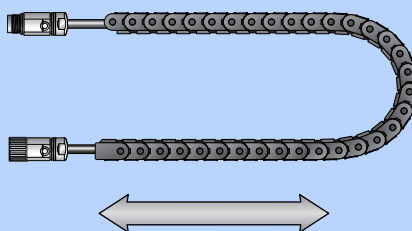

The high-flex motor cable, type KS, is suitable for applications with moving motor cables, where the cable is run inside a cable track, and is subject to roll-up motion. High-Flex cable is supplied without the cable track.

Robot Motor Cable KR

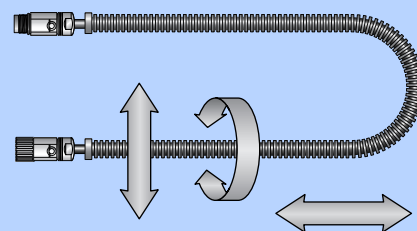

If the motor cable is subject to torsional motion, then the special robot cable, type KR, is used. In order to protect the robot cable from mechanical damage, it should be run in an appropriate cable conduit.

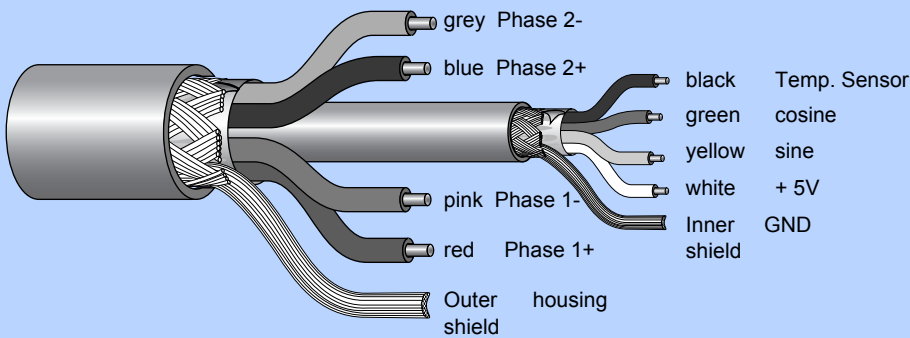

A single motor cable is sufficient to connect the linear motor and Servo Drive. It contains the motor phases and sensor signals from the position sensors integrated in the motor.

All LinMot motor cables have separate shielding for the motor phases and the sensor signals. This special double shielding ensures fault-free operation of linear motors at up to 50m cable lengths.

Flat Ribbon Cable KF

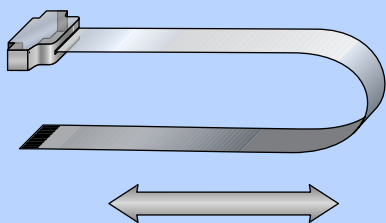

For the short motor P02-23Sx80, a flat ribbon cable is available with the designation KF. The flat ribbon cable can be subjected to roll-up motion, just as the high-flex cable. Due to its low level of predection, the flat ribbon cable is more suitable for device design than for machine building.

Motor Cable, Bulk Goods

LinMot motor cable is available by the meter in all versions, K, KS, and KR. The cable can be cut to the desired length, or ordered in large quantities on rolls.

LinMot provides all of its motor connectors for customer fabrication of motor cables. Motor cables fabricated by the customer are to be tested with a test voltage of 1500VDC prior to startup.

Fabricated Motor Cable

Fabricated motor cables can be provided with any desired length up to 50m. The motor cable is ordered in the desired length, together with the matching motor connectors (fabricated).

Fabricated motor cables with the most commonly used connector combinations can be ordered from stock in standard lengths.

Fabricated motor cables from LinMot are manufactured exclusively with crimped contacts, and tested under 1500VDC prior to delivery.

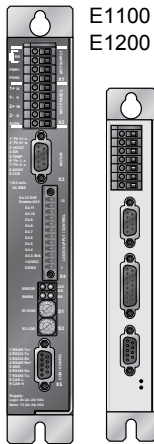

E1100
E1200

B1100
B1150
C1200

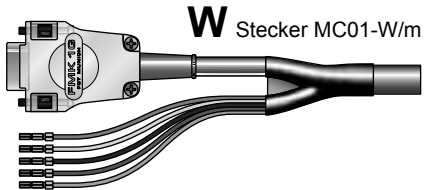

W Stecker MC01-W/m

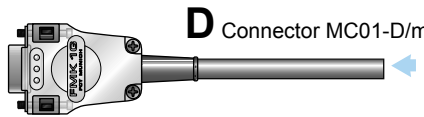

D Connector MC01-D/m

Only for stators with current within the drive's connector specification.

Standard cable K15-04/05

High flex cable KS10-04/05

Robot cable KR10-04/05



E1100: D-sub connector up to 5 A_{rms} / 7.5 A_{peak}
For UL, use W connectors only

B1100: D-sub connector up to 3 A_{rms} / 4.5 A_{peak}



E1001

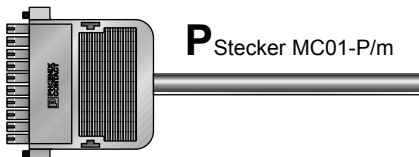

P Stecker MC01-P/m



Standard cable K05-04/05

High flex cable KS05-04/05

Robot cable KR05-04/05

- For the connection between the linear motor and Servo Drive, only the specially shielded LinMot cables of type K, KS or KR should be used.
- The length of the cable can be up to 50 m between the linear motor and the Servo Drive.
- Motor cables fabricated by the customer are to be tested with a test voltage of 1500VDC.
- An improperly fabricated motor cable can damage both the linear motor and the Servo Drive.
- The minimum bend radius is to be observed for stationary cables as well as for moving motor cables.
- The motor cable must not be plugged in or unplugged while under voltage.

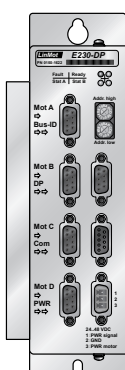

E100

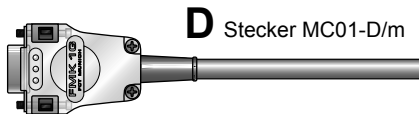

D Stecker MC01-D/m

Ordering Example:

4m high flex cable for Servo Drive E1100 and linear motor PS01-23x160-R:
- KS05-D/R-4

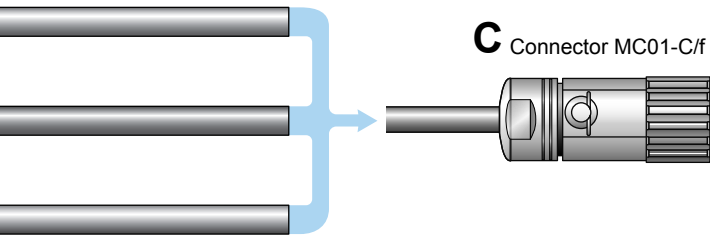

Connector Type		PS01-48X240-C PS01-48x240F-C
		PS01-37x240F-C
Cable Type		PS01-37X240F-C20

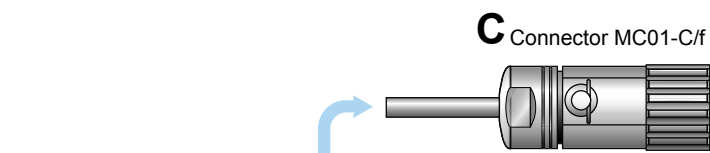

Connector Type		PS01-48X240-C PS01-48X240F-C
		PS01-37X240-C PS01-37X240F-C PS01-37x120-C PS01-37x120F-HP-C
Cable Type		PS01-37X240-C20 PS01-37X240F-C20 PS01-37X120-C20 PS01-37X120F-HP-C20

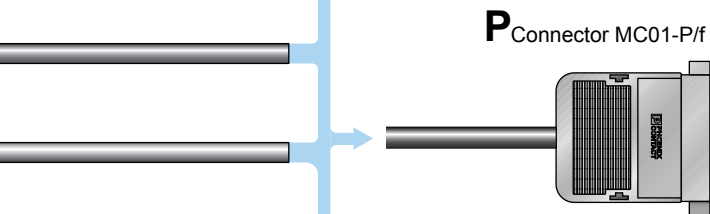

Cable Type		PS01-37x240 PS01-37X120
------------	--	----------------------------

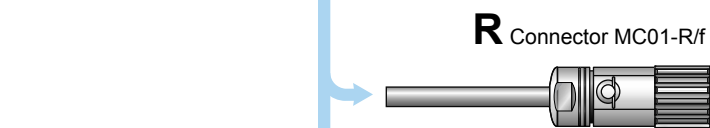

Connector Type		PS01-23x160-R PS01-23x160F-R PS01-23x160G-HP-R PS01-23x80-R
Cable Type		PS01-23x160-R20 PS01-23x160F-R20 PS01-23x160G-HP-R20 PS01-23x80-R20

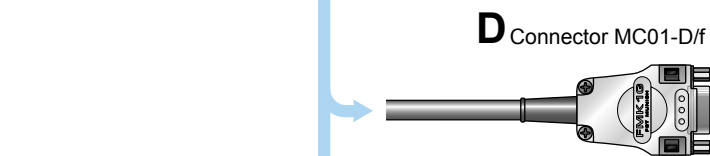

Cable Type		PS01-23x160 PS01-23x80
------------	--	---------------------------

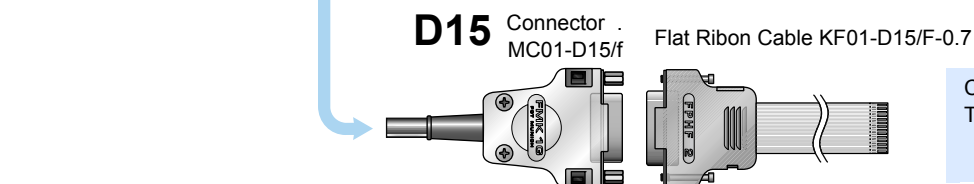

Cable Type		PS02-23Sx80
------------	--	-------------

Fabricated Motor Cables standard lengths

Item	Description	Part Number
MOTOR CABLE ASSEMBLED STANDARD		
K05-D/D-2	motor cable D/D, 2 m	0150-1910
K05-D/D-4	motor cable D/D, 4 m	0150-1911
K05-D/D-6	motor cable D/D, 6 m	0150-1912
K05-D/D-8	motor cable D/D, 8 m	0150-1913
K05-D/P-0.25	motor cable D/P, 0.25m	0150-1921
K05-D/P-2	motor cable D/P, 2 m	0150-1949
K05-D/P-4	motor cable D/P, 4 m	0150-1995
K05-D/P-6	motor cable D/P, 6 m	0150-1994
K05-D/R-2	motor cable D/R, 2 m	0150-1832
K05-D/R-4	motor cable D/R, 4 m	0150-1833
K05-D/R-6	motor cable D/R, 6 m	0150-1834
K05-D/R-8	motor cable D/R, 8 m	0150-1835
K05-D/C-2	motor cable D/C, 2 m	0150-1819
K05-D/C-4	motor cable D/C, 4 m	0150-1820
K05-D/C-6	motor cable D/C, 6 m	0150-1821
K05-D/C-8	motor cable D/C, 8 m	0150-1822
K05-P/D-0.4	motor cable P/D, 0.4 m	0150-1922
K05-P/P-2	motor cable P/P, 2 m	0150-1915
K05-P/P-4	motor cable P/P, 4 m	0150-1916
K05-P/P-6	motor cable P/P, 6 m	0150-1917
K05-P/P-8	motor cable P/P, 8 m	0150-1918
K05-P/C-2	motor cable P/C, 2 m	0150-1818
K05-P/C-4	motor cable P/C, 4 m	0150-1804
K05-P/C-6	motor cable P/C, 6 m	0150-1805
K05-P/C-8	motor cable P/C, 8 m	0150-1806
K05-W/R-2	motor cable W/R, 2 m	0150-2119
K05-W/R-4	motor cable W/R, 4 m	0150-2120
K05-W/R-6	motor cable W/R, 6 m	0150-2121
K05-W/R-8	motor cable W/R, 8 m	0150-2122
K05-W/C-2	motor cable W/C, 2 m	0150-2123
KS05-W/N-2	motor cable W/C, 2 m	0150-2296
KS05-W/N-4	motor cable W/C, 2 m	0150-2297
KS05-W/N-6	motor cable W/C, 2 m	0150-2298
KS05-W/N-8	motor cable W/C, 2 m	0150-2299
K05-W/C-4	motor cable W/C, 4 m	0150-2124
K05-W/C-6	motor cable W/C, 6 m	0150-2125
K05-W/C-8	motor cable W/C, 8 m	0150-2126
K05-W/D-0.4	motor cable W/D, 0.4 m	0150-1947
K05-W/P-0.4	motor cable W/P, 0.4 m	0150-1948
K15-W/C-2	motor cable W/C, 2 m	0150-1811
K15-W/C-4	motor cable W/C, 4 m	0150-1801
K15-W/C-5	motor cable W/C, 5 m	0150-1849
K15-W/C-6	motor cable W/C, 6 m	0150-1802
K15-W/C-8	motor cable W/C, 8 m	0150-1803
MOTOR CABLE ASSEMBLED HIGH FLEX		
KS05-D/D-2	trailing chain cable D/D, 2 m	0150-1988
KS05-D/D-4	trailing chain cable D/D, 4 m	0150-1989
KS05-D/R-2	trailing chain cable D/R, 2 m	0150-1854
KS05-D/R-4	trailing chain cable D/R, 4 m	0150-1836
KS05-D/R-6	trailing chain cable D/R, 6 m	0150-1855
KS05-D/R-8	trailing chain cable D/R, 8 m	0150-1837
KS05-D/C-2	trailing chain cable D/C, 2m	0150-1856
KS05-D/C-4	trailing chain cable D/C, 4 m	0150-1823
KS05-D/C-6	trailing chain cable D/C, 6 m	0150-1857
KS05-D/C-8	trailing chain cable D/C, 8 m	0150-1824
KS05-P/P-2	trailing chain cable P/P, 2 m	0150-1990
KS05-P/P-4	trailing chain cable P/P, 4 m	0150-1991
KS05-P/C-4	trailing chain cable P/C, 4 m	0150-1809
KS05-P/C-8	trailing chain cable P/C, 8 m	0150-1810
KS05-R/R-2	trailing chain cable R/R, 2 m	0150-1838
KS05-R/R-4	trailing chain cable R/R, 4 m	0150-1839
KS05-W/C-4	trailing chain cable W/C, 4 m	0150-2127
KS05-W/C-6	trailing chain cable W/C, 6 m	0150-2128
KS05-W/C-8	trailing chain cable W/C, 8 m	0150-2129
KS05-W/R-4	trailing chain cable W/R, 4 m	0150-2106
KS05-W/R-6	trailing chain cable W/R, 6 m	0150-2131
KS05-W/R-8	trailing chain cable W/R, 8 m	0150-2107
KS05-C/C-2	trailing chain cable C/C, 2 m	0150-1827
KS05-C/C-4	trailing chain cable C/C, 4 m	0150-1828
KS10-C/C-2	trailing chain cable C/C, 2 m	0150-1816
KS10-C/C-4	trailing chain cable C/C, 4 m	0150-1817
KS10-W/C-4	trailing chain cable W/C, 4 m	0150-1807
KS10-W/C-5	trailing chain cable W/C, 5 m	0150-1860
KS10-W/C-6	trailing chain cable W/C, 6 m	0150-1858
KS10-W/C-8	trailing chain cable W/C, 8 m	0150-1808
POWER & ENCODER CABLE FOR LINEAR MOTORS P10-70 (3x400...480VAC)		
KPS15-04-L/Q-3	power trailing chain cable L/Q, 3m	0150-2266
KPS15-04-L/Q-5	power trailing chain cable L/Q, 5m	0150-2261
KPS15-04-L/Q-8	power trailing chain cable L/Q, 8m	0150-2267
KPS15-04-L/Q-12	power trailing chain cable L/Q, 12m	0150-2268
KSS05-02/08-D15/J-3	encoder trailing chain cable D15/J, 3m	0150-2263
KSS05-02/08-D15/J-5	encoder trailing chain cable D15/J, 5m	0150-2262
KSS05-02/08-D15/J-8	encoder trailing chain cable D15/J, 8m	0150-2264
KSS05-02/08-D15/J-12	encoder trailing chain cable D15/J, 12m	0150-2265

Motor Cable and Connectors

Item	Description	Part Number
MOTOR CABLE PER M		
K05-04/05	motor cable per m	0150-1920
K05-04/05-50	motor cable 50m roll	0150-1956
K05-04/05-100	motor cable 100m roll	0150-1957
K05-04/05-200	motor cable 200m roll	0150-1958
K15-04/05	motor cable per m	0150-1978
K15-04/05-100	motor cable, 100 m roll	0150-1969
KS03-09	trailing chain cable per m (max. 2m)	0150-2182
KS05-04/05	trailing chain cable (per m)	0150-1938
KS05-04/05-100	trailing chain cable 100 m roll	0150-1959
KS10-04/05	trailing chain cable per m	0150-1977
KS10-04/05-100	trailing chain cable, 100m roll	0150-1968
KR05-04/05	robotic cable (per m)	0150-1846
KR05-04/05-100	robotic cable, 100m roll	0150-1847
KR10-04/05	robotic cable (per m)	0150-1830
KR10-04/05-100	robotic cable, 100m roll	0150-1831
MOTOR CONECTORS, ASSEMBLED CONECTORS		
MC01-D/m	motor connector D (m)	0150-3024
MC01-D/f	motor connector D (f)	0150-3025
MC01-D15/f	motor connector D15/f	0150-3136
MC01-K/f	motor connector K (f)	0150-3345
MC01-P/m	motor connector P (m)	0150-3020
MC01-P/f	motor connector P(f)	0150-3021
MC01-R/m	motor connector R/m	0150-3130
MC01-R/f	motor connector R/f	0150-3129
MC01-N/f	motor connector N/f	0150-3407
MC01-C/m	motor connector C/m	0150-3093
MC01-C/f	motor connector C/f	0150-3080
MC01-W/m	motor connector W/m	0150-3140
MC01-D/m-as	D/m-connector assembled	0150-3055
MC01-D/f-as	D/f-connector assembled	0150-3142
MC01-D15/m-as	D15/m-connector assembled	0150-3148
MC01-D15/f-as	D15/f-connector assembled	0150-3073
MC01-K/f-as	K/f-connector assembled	0150-3346
MC01-P/m-as	P/m-connector assembled	0150-3056
MC01-P/f-as	P/f-connector assembled	0150-3144
MC01-R/m-as	R/m-connector assembled	0150-3097
MC01-R/f-as	R/f-connector assembled	0150-3143
MC01-N/f-as	N/f-connector assembled	0150-3408
MC01-C/m-as	C/m-connector assembled	0150-3099
MC01-C/f-as	C/f-connector assembled	0150-3146
MC01-W/m-as	W/m-connector assembled	0150-3147
MOTOR CONECTORS IP69K, ASSEMBLED CONECTORS IP69K		
MC01-R/f-IP69K	motor connector R/f, IP69K	0150-3341
MC01-R/f-IP69K-SSC	motor connector R/f, IP69K, SSC	0150-3347
MC01-C/f-IP69K	motor connector C/f, IP69K	0150-3339
MC01-C/f-IP69K-SSC	motor connector C/f, IP69K, SSC	0150-3306
MC01-R/f-IP69K-as	motor connector R/f, IP69K, assembled	0150-3342
MC01-R/f-IP69K-SSC-as	motor connector R/f, IP69K, SSC, assembled	0150-3343
MC01-C/f-IP69K-as	motor connector C/f, IP69K, assembled	0150-3340
MC01-C/f-IP69K-SSC-as	motor connector C/f, IP69K, SSC, assembled	0150-3325
MOTOR CABLE FOR SHORT MOTOR P02-23Sx80-F		
KF02-D15/F-0.70	flat cable 0.7m, for PS02-23Sx80-F	0150-2158
KF02-D15/F-0.48	flat cable 0.48m, for PS02-23Sx80-F	0150-2154
KF02-D15/F-0.32	flat cable 0.32m, for PS02-23Sx80-F	0150-2152
KF02-D15/F-0.16	flat cable 0.16m, for PS02-23Sx80-F	0150-2156
KF02-D15/F-0.08	flat cable 0.08m, for PS02-23Sx80-F	0150-2150
K05-D/D15-1	adapter cable D/D15, 1m (for PS02-23Sx80)	0150-1936
MOTOR CABLE FOR SHORT MOTOR P02-23Sx80F-HP-K		
KS03-W/K-2	trailing chain cable W/K 2m	0150-2187
KS03-R/K-1	trailing chain cable R/K 1m	0150-2185
KS03-R/K-2	trailing chain cable R/K 2m	0150-2186
CABLE AND CONNECTORS FOR LINEAR MOTORS P10-70 (3x400...480VAC)		
KPS15-04	trailing chain cable power (per m)	0150-2257
KSS05-02/08	trailing chain cable encoder (per m)	0150-2258
MC10-L/m	Drive connector power MC10-L/m	0150-3382
MC10-Q/m	Motor connector Q/m	0160-2405
MC10-Q/f	Motor connector MC10-Q/f	0160-2268
MC10-D15-45°/f	Drive connector encoder D15-45°/f	0150-3397
MC10-J/m	Motor connector encoder MC10-J17/m	0160-2407
MC10-J/f	Motor connector encoder MC10-J/f	0160-2269
MC10-L/m-as	Connector L/m assembled	0160-2330
MC10-Q/m-as	Connector Q/m assembled	0160-2406
MC10-Q/f-as	Connector Q/f assembled	0160-2329
MC10-D15-45°/f-as	Connector D15-45°(f) assembled	0150-3399
MC10-J/m-as	Connector J/m assembled	0160-2408
MC10-J/f-as	Connector J/f assembled	0160-2331

R-Connector

MC01-R/m

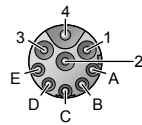
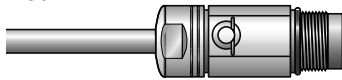

MC01-R/f

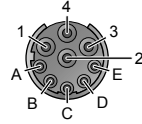
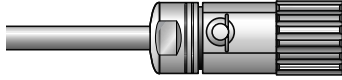

1	Phase 1+	red
2	Phase 1-	pink
3	Phase 2+	blue
4	Phase 2-	grey
A	+5V	white
B	GND	inner shield
C	Sensor sine	yellow
D	Sensor cosine	green
E	Temp. Sensor	black
housing	shield	outer shield

MC01-F/R

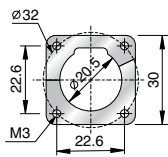

Mounting-window:

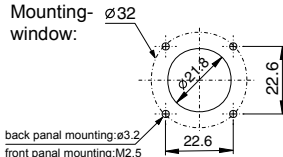

Item	Part Number
MC01-R/m	0150-3130
MC01-R/f	0150-3129
MC01-R/m-as (assembled)	0150-3097
MC01-R/f -as (assembled)	0150-3143
MC01-F/R Connector Flange	0150-3253
MC01-R/m-cap	0150-3376
MC01-R/f-cap	0150-3377

MC01-R/m-cap



MC01-R/m-cap



C-Connector

MC01-C/m

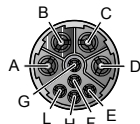

MC01-C/f

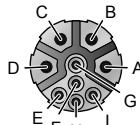
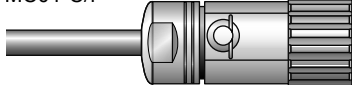

A	Phase 1+	red
B	Phase 1-	pink
C	Phase 2+	blue
D	Phase 2-	grey
E	+5V	white
F	GND	inner shield
G	Sensor sine	yellow
H	Sensor cosine	green
L	Temp. Sensor	black
housing	shield	outer shield

MC01-F/C

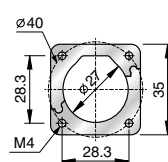

Mounting-window:

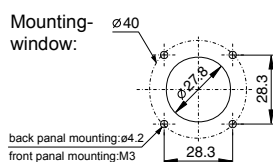

Item	Part Number
MC01-C/m	0150-3093
MC01-C/f	0150-3080
MC01-C/m-as (assembled)	0150-3099
MC01-C/f-as (assembled)	0150-3146
MC01-F/C Connector Flange	0150-3254
MC01-C/m-cap	0150-3378
MC01-C/f-cap	0150-3379

MC01-C/m-cap



MC01-C/m-cap



W-Connector

MC01-W/m

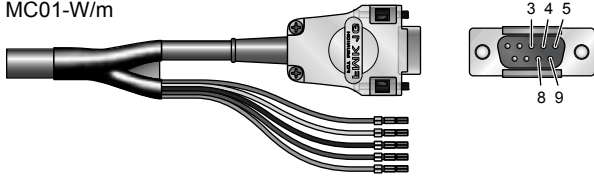

strand red	Phase 1+	red
strand pink	Phase 1-	pink
strand blue	Phase 2+	blue
strand grey	Phase 2-	grey
3	+5V	white
8	GND	inner shield
4	Sensor sine	yellow
9	Sensor cosine	green
5	Temp. Sensor	black
shield	shield	outer shield

Item	Part Number
MC01-W/m	0150-3140
MC01-W/m-as (assembled)	0150-3147

D-Connector

MC01-D/m

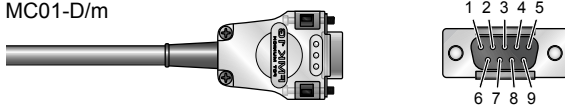

1	Phase 1+	red
6	Phase 1-	pink
2	Phase 2+	blue
7	Phase 2-	grey
3	+5V	white
8	GND	inner shield
4	Sensor sine	yellow
9	Sensor cosine	green
5	Temp. Sensor	black
housing	shield	outer shield

Item	Part Number
MC01-D/m	0150-3024
MC01-D/f	0150-3025
MC01-D/m-as (assembled)	0150-3055
MC01-D/f-as (assembled)	0150-3142

MC01-D/f

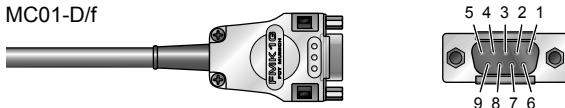

P-Connector

MC01-P/m

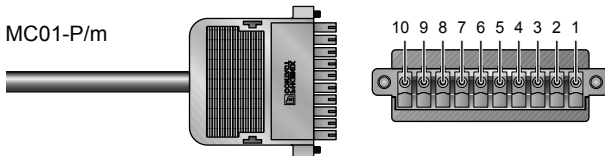

1	Phase 1+	red
2	Phase 1-	pink
3	Phase 2+	blue
4	Phase 2-	grey
5	+5V	white
6	GND	inner shield
7	Sensor sine	yellow
8	Sensor cosine	green
9	Temp. Sensor	black
10	shield	outer shield

Item	Part Number
MC01-P/m	0150-3020
MC01-P/f	0150-3021
MC01-P/m-as (assembled)	0150-3056
MC01-P/f-as (assembled)	0150-3144

MC01-P/f

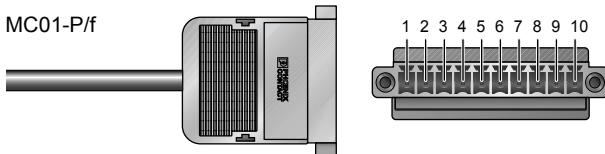

Shrink tubing for IP67 connectors

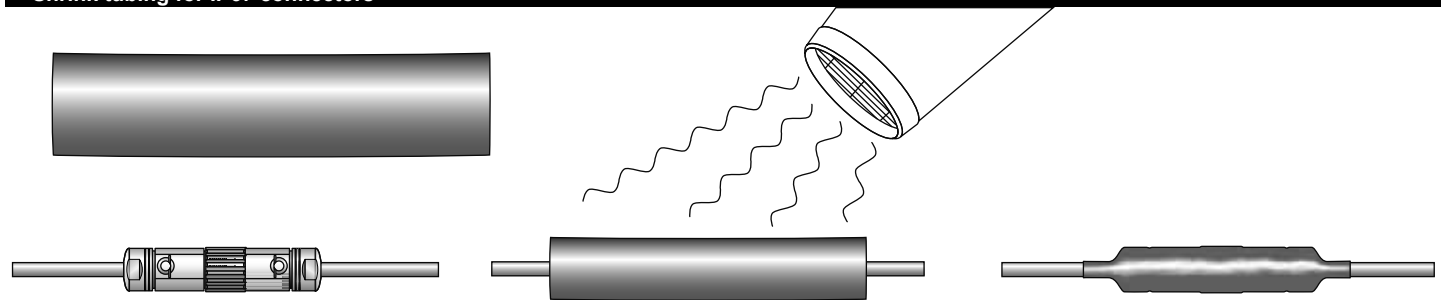

Item	Material	Part Number
MCP01-18 Shrink tubing (with hot glue coating) for additional protection of IP67 connectors	Polyolefin	0150-3089

K-Connector

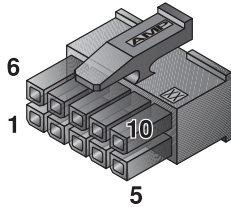
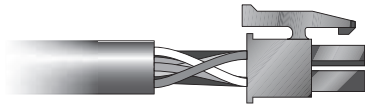

1	red	Phase 1+
2	blue	Phase 2+
4	rose	Phase 1-
5	grey	Phase 2-
6	yellow	Sensor sine
7	green	Sensor cosine
8	brown	GND
9	white	+5V
10	black	Temp. Sensor
housing	shield	outer shield

Item	Part Number
MC01-K/f	0150-3345
MC01-K/f-as (assembled)	0150-3346

N-Connector

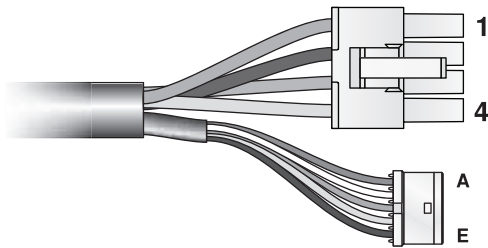

1	red	Phase 1+
2	rose	Phase 1-
3	blue	Phase 2+
4	grey	Phase 2-
A	white	+5V
B	inner shield	GND
C	yellow	Sensor sine
D	green	Sensor cosine
E	black	Temp sensor
housing	outer shield	housing

Item	Part Number
MC01-N/f	0150-3407
MC01-N/f-as (assembled)	0150-3408

F-Connector

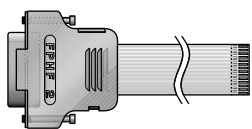

MC01-D15W/f

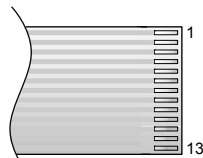

ZIF-Line Molex
pitch 1.25mm



Plugging in or unplugging the flat ribbon cable under voltage can damage the motor and drive.

12 & 13	Phase 2-	12 & 13
3 & 4	Phase 2+	3 & 4
10 & 11	Phase 1-	10 & 11
1 & 2	Phase 1+	1 & 2
5	Sensor sine	5
7	GND	7
9	+5V	9
8	Temp. Sensor	8
6	Sensor cosine	6

Item	Part Number
KF02-D15/F-...	see Page 513

Flat ribbon cable with D15/m-Connector

D15-Connector

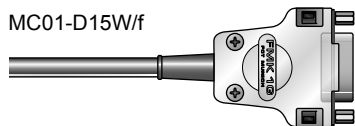

MC01-D15W/f

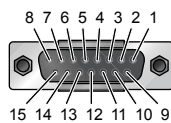

7 & 15	Phase 1+	red
3 & 10	Phase 1-	pink
6 & 14	Phase 2+	blue
2 & 9	Phase 2-	grey
11	+5V	white
12	GND	inner shield
13	Sensor sine	yellow
5	Sensor cosine	green
4	Temp. Sensor	black
housing	shield	outer shield

Item	Part Number
MC01-D15/f	0150-3136
MC01-D15/f-as (assembled)	0150-3073

LinMot Cable

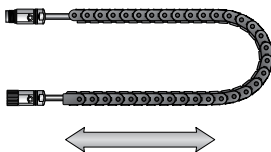
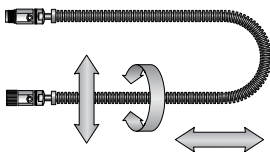
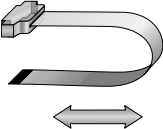
	Standard cable		High Flex cable		Robot cable		Flat ribbon cable
							
Cable Type	K05-04/05	K15-04/05	KS05-04/05	KS10-04/05	KR05-04/05	KR10-04/05	KF02-D15/F-...
Diameter	0.5mm ²	1.5mm ²	0.5mm ²	1.0mm ²	0.5mm ²	1.0mm ²	
Motor phases	(AWG20)	(AWG16)	(AWG20)	(AWG18)	(AWG20)	(AWG18)	
Diameter		0.14mm ²		0.14mm ²		0.14mm ²	
Sensor signals		(AWG26)		(AWG26)		(AWG26)	
Inner isolation material	TPE-U		TPE-E		TPE-E		Polyester
Outer isolation material	PUR		PUR		PUR		
Cable color	black		black		black		white
Cable diameter	8.2mm (0.31in)	11.2mm (0.44in)	9.5mm (0.38in)	10.8mm (0.42in)	9.7mm (0.38in)	10.9mm (0.43in)	17.8x0.2mm (0.7x0.008in)
Weight	83kg/km	180kg/km	113kg/km	139kg/km	109kg/km	136kg/km	
Approvals	Materials according UL		UL / CSA 300V		UL / CSA 300V		
Minimal bending radius fix installed	25mm (1in)	50mm (2in)	30mm (1.2in)	50mm (2in)	30mm (1.2in)	50mm (2in)	foldable
Minimal bending radius moving	do not use in applications with moving motor cable		60mm (2.4in) no torsion	100mm (4in) no torsion	60mm (2.4in) Maximal torsion: ±270° per 0.5m	100mm (4in) Maximal torsion: ±270° per 0.5m	25mm
Temperature range	-40°...+80°C		-40°...+80°C		-40°...+80°C		-55°...+105°C
Available lengths	cable per m cable on rolls 50m, 100m, 200m		cable per m cable on rolls 100m		cable per m cable on rolls 100m		0.08-0.7m

Ordering information

	Standard cable		High-Flex cable		Robot cable		Flat ribbon cable
	0.5mm ²	1.5mm ²	0.5mm ²	1.0mm ²	0.5mm ²	1.0mm ²	
Cable per m	K05-04/05	K15-04/05	KS05-04/05	KS10-04/05	KR05-04/05	KR10-04/05	
	0150-1920	0150-1978	0150-1938	0150-1977	0150-1846	0150-1830	
Rolls 50m	K05-04/05-50						
	0150-1956						
Rolls 100m	K05-04/05-100	K15-04/05-100	KS05-04/05-100	KS10-04/05-100	KR05-04/05-100	KR10-04/05-100	
	0150-1957	0150-1969	0150-1959	0150-1968	0150-1847	0150-1831	
Rolls 200m	K05-04/05-200						
	0150-1958						
Single cable							KF02-D15/F-...

Motor Flanges

LinMot PF motor flanges allow simple and rapid mounting of LinMot P linear motors. The clamp plate design allows rapid and simple mounting/dismounting of linear motors, without removing the flange from the motor.

An appropriate flange, with the correct length, is available for each linear motor family. This not only ensures secure mechanical mounting, but also guarantees optimal cooling of the linear motor.

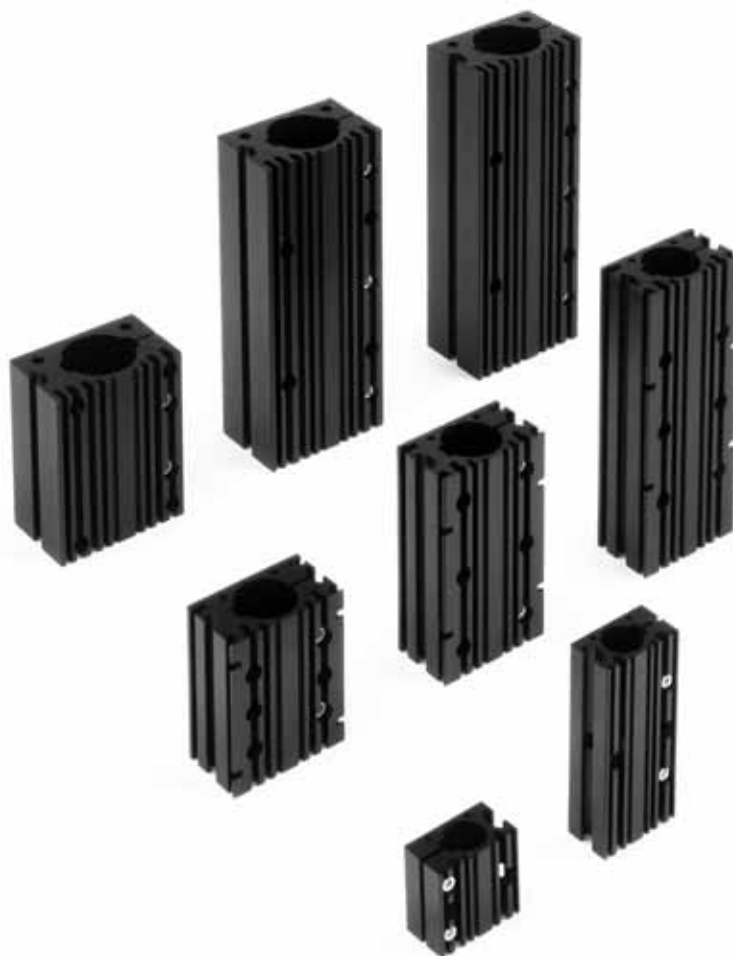

Stator Mounting

The same flange is used for stators with cable exits or connector housings. The stator is secured in the flange with clamping screws, so that the stator is clamped over a large area.

When the stator is mounted, the maximum screw torque should be observed and not exceeded.

Clamping over a large area, practically across the entire length of the stator, as well as the cooling fins on the flange, ensure optimal cooling of the linear motor.

Flange Mount Option

Depending on the application and installation space, the flanges can be mounted horizontally or vertically.

For horizontal installation, the flange is secured using screws in the through holes.

For vertical mounting, it is attached with T-nuts, using the T-slot on the narrow side of the flange.

Additional T-slots on the upper side of the flange allow accessories to be mounted easily.

Optional Fan

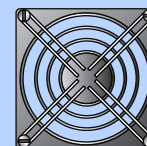
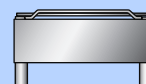

With an optional fan, the effective force of the linear motor can be nearly doubled.

Mounting with Screwholes

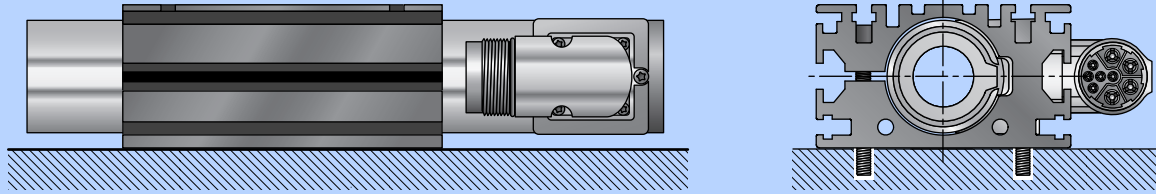

Mounting with T-Nut

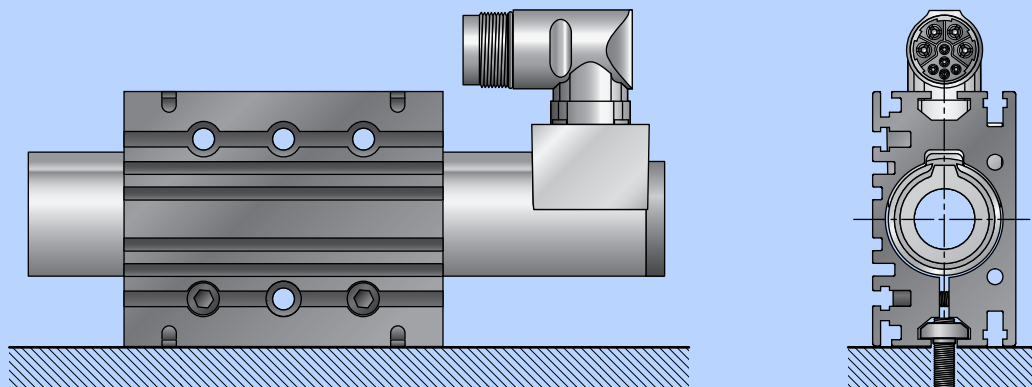

Ordering information

Item	Description	Part Number
PF02-23x50	Flange for Linear Motors P01-23x80	0150-2102
PF02-23x120	Flange for Linear Motors P01-23x160	0150-2103
PF02-23x170	Flange for Linear Motors P01-23x160	0150-2117
PF02-37x100	Flange for Linear Motors P01-37x120	0150-1998
PF02-37x140	Flange for Linear Motors P01-37x120	0150-2105
PF02-37x200	Flange for Linear Motors P01-37x240	0150-1999
PF01-48x120	Flange for Linear Motors P01-48x240	0150-1976
PF01-48x226	Flange for Linear Motors P01-48x240	0150-2108
PF01-48x346	Flange for Linear Motors P01-48x360	0150-2145

PF02-23

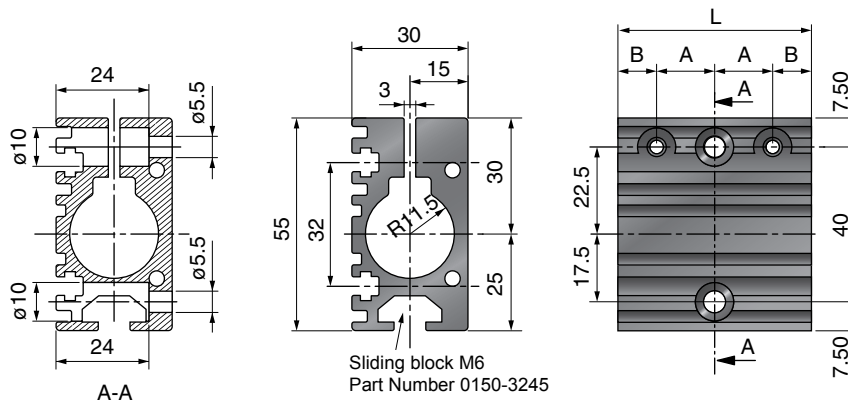

Max. torque for clamp plate screws: 4Nm

Sliding block M6
Part Number 0150-3245

Item	Description	L [mm]	A [mm]	B [mm]	Weight [g]	Part Number
PF02-23x50	Flange 23x50 mm	50	15	10	115	0150-2102
PF02-23x120	Flange 23x120 mm	120	30	30	280	0150-2103
PF02-23x170	Flange 23x170 mm	170	45	40	390	0150-2117

PF02-37

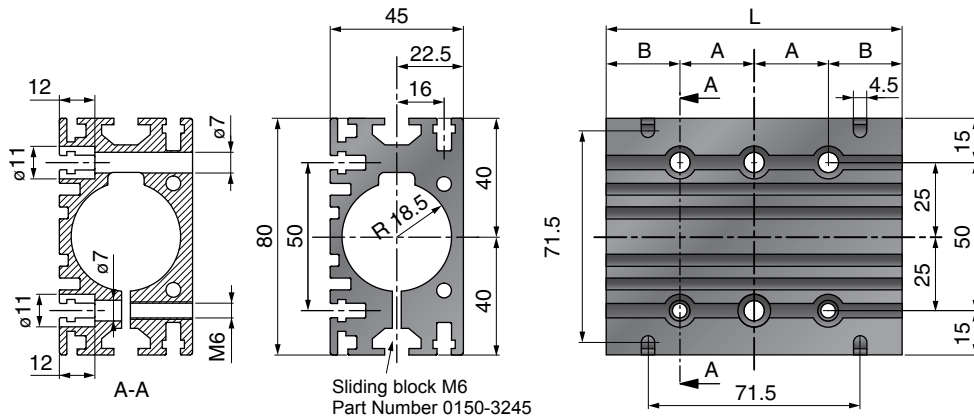

Max. torque for clamp plate screws: 8Nm

Sliding block M6
Part Number 0150-3245

Item	Description	L [mm]	A [mm]	B [mm]	Weight [g]	Part Number
PF02-37x100	Flange 37x100 mm	100	25	25	450	0150-1998
PF02-37x140	Flange 37x140 mm	140	50	20	630	0150-2105
PF02-37x200	Flange 37x200 mm	200	50	50	920	0150-1999

PF01-48

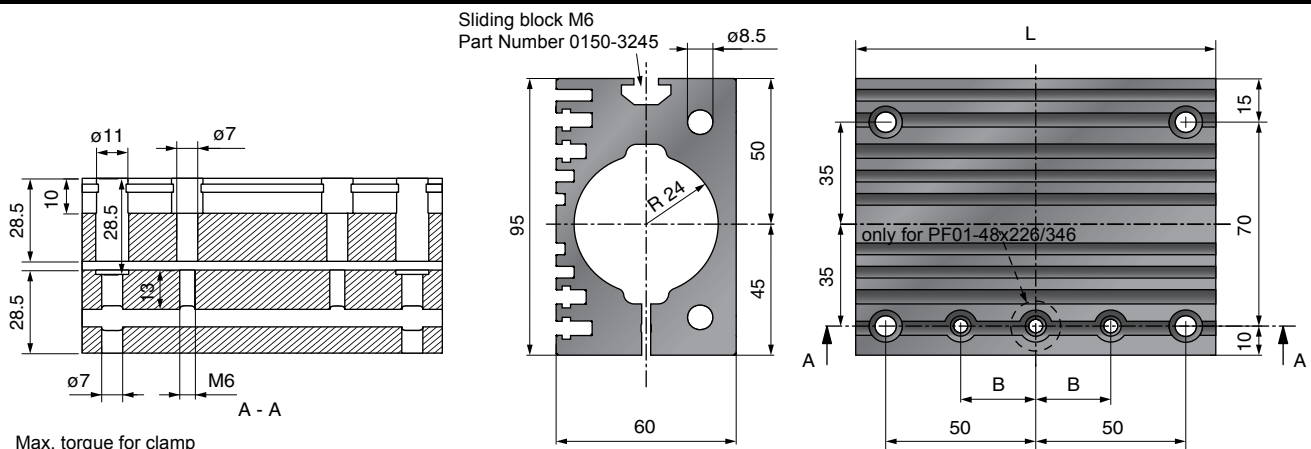

Max. torque for clamp plate screws: 12Nm

Sliding block M6
Part Number 0150-3245

Item	Description	L [mm]	B [mm]	Weight [g]	Part Number
PF01-48x120	Flange 48x120 mm	120	25	970	0150-1976
PF01-48x226	Flange 48x226 mm	226	85	1850	0150-2108
PF01-48x346	Flange 48x346 mm	346	100*	2650	0150-2145

*Details see p. 189

Optional Fan for PF02-23

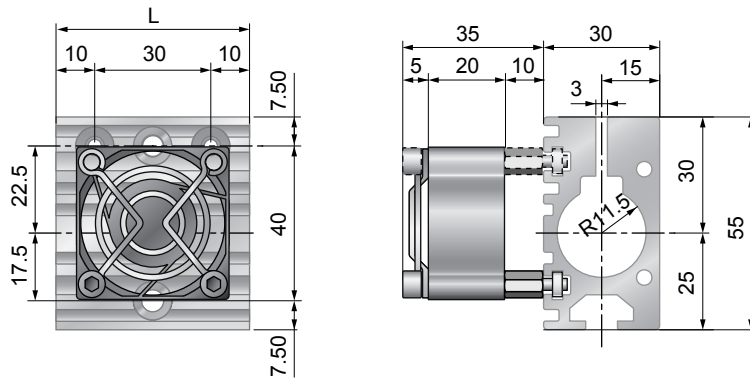

Fan supply:
24VDC, 70mA

Air flow:
15m³/h

Item	Description	Part Number
HV01-23	Fan kit for H01-23 and PF02-23	0150-5050

Optional Fan for PF02-37

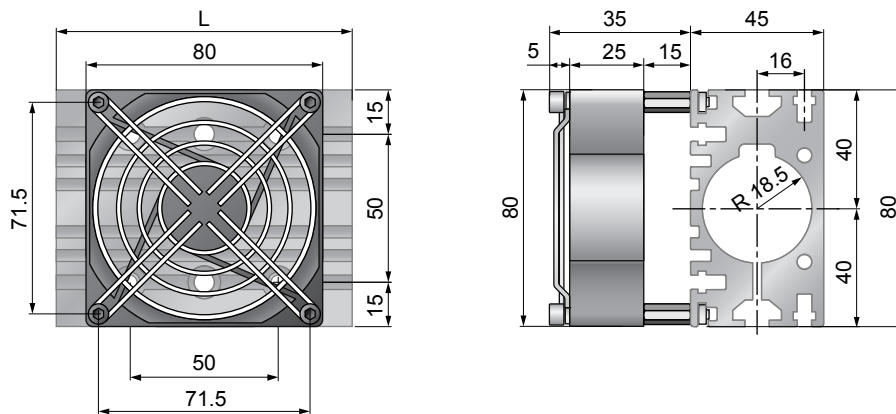

Fan supply:
24VDC, 120mA

Air flow:
80m³/h

Item	Description	Part Number
HV01-37/48	Fan kit for H01-37, B01-37 and PF02-37	0150-5051

Optional Fan for PF01-48

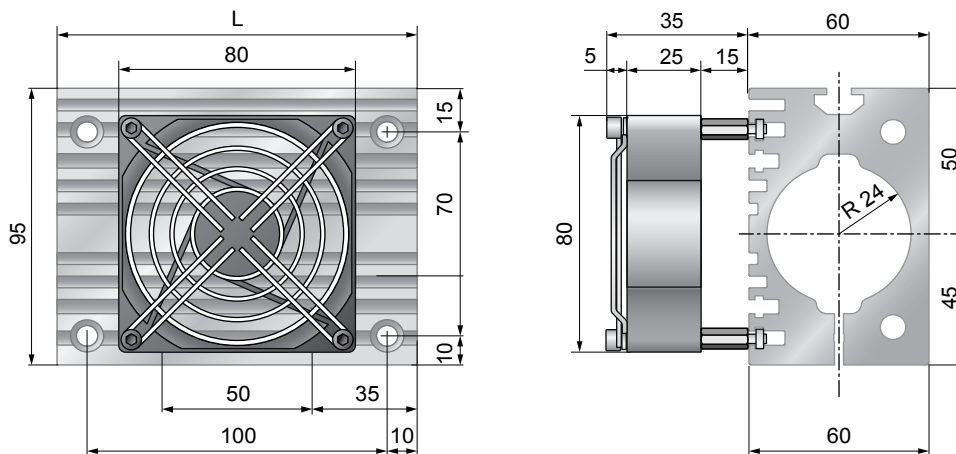

Fan supply:
24VDC, 120mA

Air flow:
80m³/h

Item	Description	Part Number
HV01-37/48	Fan kit for H01-48, B01-48 and PF01-48	0150-5051

Slider Mounts

Depending on the application, LinMot linear motors can be operated with a "moving slider" or "moving stator." Applications with short stroke ranges are preferably implemented with moving sliders; applications with long strokes are better with a moving stator. In both cases, LinMot recommends the use of special mounting kits for mounting the slider, in order to avoid overdetermining the mount.

In moving slider applications, the stator is mounted, and the slider is connected to a load that is guided by a linear guide. In order to avoid alignment errors, the slider is attached to the load or guide using fixed bearings, each consisting of two rounded washers and two bevel washers.

In moving stator applications, the slider is mounted and the stator is attached to a linear guide, together with the load. In order to avoid overdetermining the slider bearing, one end of the slider is mounted on a fixed bearing, and the other on a floating bearing.

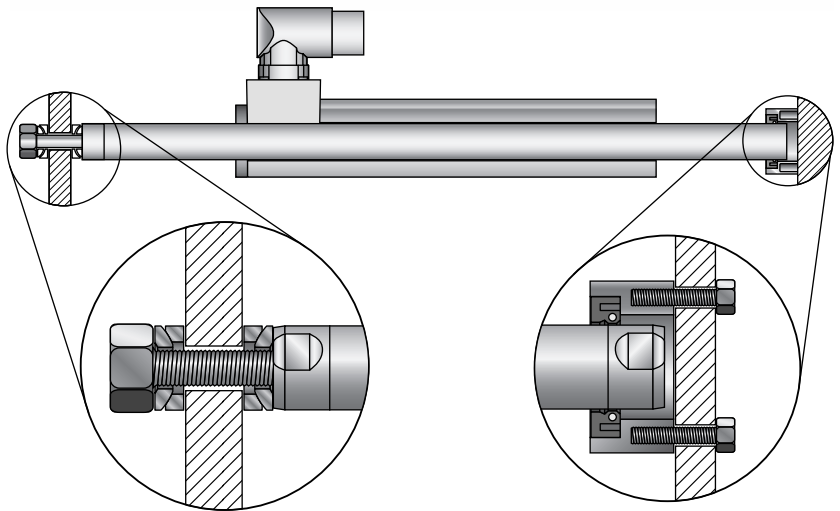

Fixed bearing

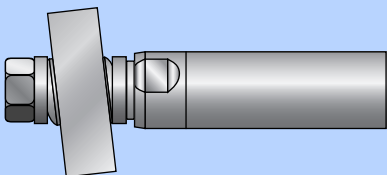

The fixed bearing consists of two rounded washers and two bevel washers. It compensates for angular and axial deflection.

Floating bearing

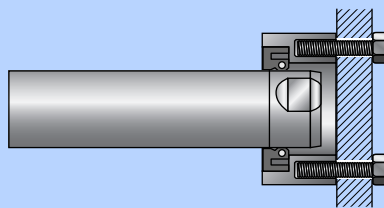

The slider is mounted in a rubber ring as a floating bearing. The floating bearing compensates for angular and axial displacement and length tolerance.

Material



Rounded and bevel washers:
Case-hardened steel



Bearing:
NBR
(Nitrile-Butadiene-Rubber with
DIN17223 spring steel)



Housing:
Stainless steel 1.4305

Moving Slider

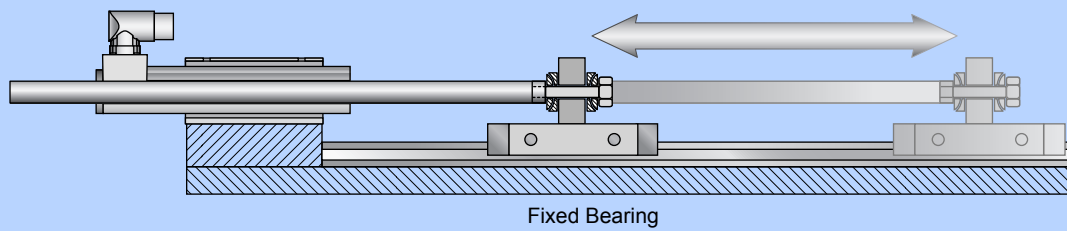

Moving Stator

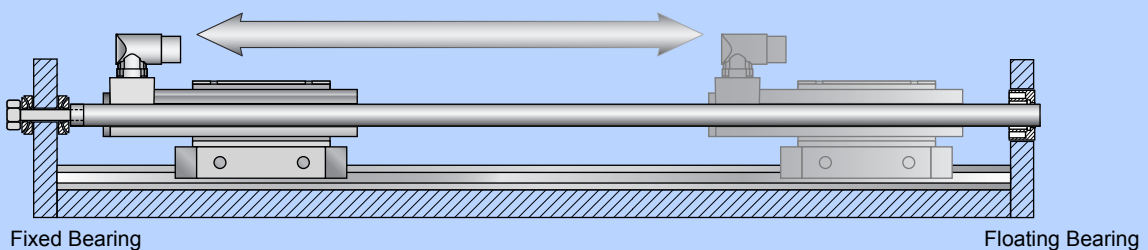

Dimensions and ordering information

Fix Bearing



DIN 6319 C

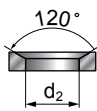

DIN 6319 D

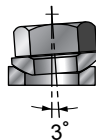
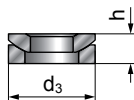

Item	Slider	Lead	d1	d2	d3	h
PLF01-12	12mm	M5	5.2mm (0.20in)	6.0mm (0.24in)	10.5mm (0.41in)	3.2mm (0.13in)
PLF01-20	20mm	M8	8.4mm (0.33in)	9.6mm (0.38in)	17mm (0.67in)	5.5mm (0.22in)
PLF01-28	28mm	M10	10.5mm (0.41in)	12mm (0.47in)	21mm (0.83in)	6.5mm (0.26in)

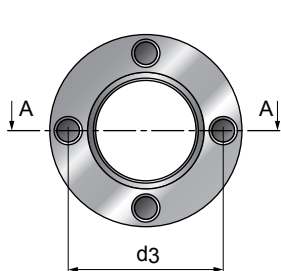

Floating Bearing

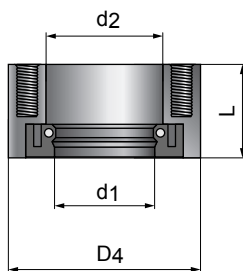

A-A

Item	Slider	Lead	d1	d2	d3	D4	L
PLL02-12	12mm	-	12mm (0.47in)	Gummi-ring	-	22mm (0.87in)	6.6mm (0.26in)
PLL01-19	19mm	M5	20mm (0.79in)	23mm (0.90in)	30mm (1.18in)	37mm (1.46in)	20mm (0.79in)
PLL01-20	20mm	M5	20mm (0.79in)	23mm (0.90in)	30mm (1.18in)	37mm (1.46in)	20mm (0.79in)
PLL01-27	27mm	M5	28mm (1.10in)	32mm (1.26in)	40mm (1.57in)	48mm (1.89in)	20mm (0.79in)
PLL01-28	28mm	M5	28mm (1.10in)	32mm (1.26in)	40mm (1.57in)	48mm (1.89in)	20mm (0.79in)

Item	Description	Part Number
PLF01-12	Fix bearing for 12mm slider	0150-3085
PLF01-20	Fix bearing for 20mm slider	0150-3083
PLF01-28	Fix bearing for 28mm slider	0150-3087
PLL02-12	Floating bearing for PL01-12 slider	0150-3111
PLL01-19	Floating bearing for PL01-19 slider	0150-3335
PLL01-20	Floating bearing for PL01-20 slider	0150-3084
PLL01-27	Floating bearing for PL01-27 slider	0150-3294
PLL01-28	Floating bearing for PL01-28 slider	0150-3094
PLM01-20-MK	Mounting kit for PL01-20 slider	0150-3079
PLM01-28-MK	Mounting kit for PL01-28 slider	0150-3095

Wipers

LinMot stators can be equipped with wipers as an option. Wipers increase the duration of the maintenance interval, and allow simple re-lubrication using the integrated lube nipple and a grease gun. The wipers also keep the slider free of grease or contaminants, and protect the stator from dirt.



Installation

LinMot stators can be equipped with wipers as an option.

Wipers increase the duration of the maintenance interval, and allow simple re-lubrication using the integrated lube nipple and a grease gun.

The wipers also keep the slider free of grease or contaminants, and protect the stator from dirt.

Wipers

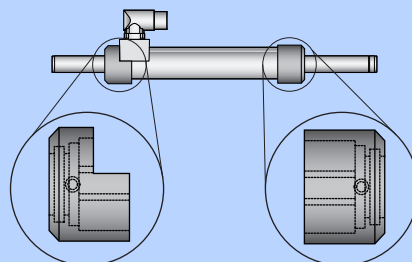

Rear Wiper

Front Wiper

Material

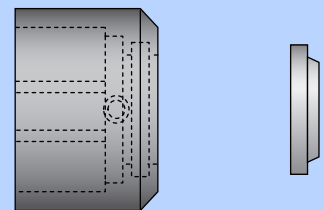

Housing: POM

Wipers: H-PU

Available Wipers

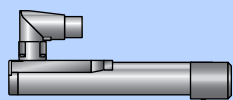

P01-23x80

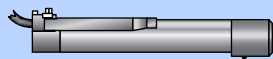

P01-37x120

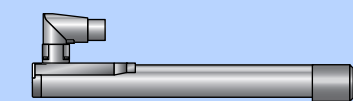

P01-23x160

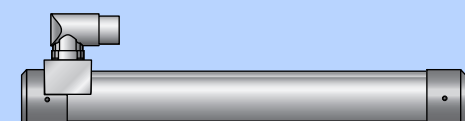

P01-37x240

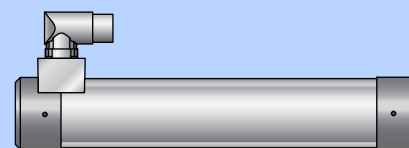

P01-48x240

Dimensions and ordering information

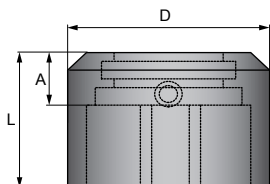

Item	D	L	A	Weight
PA01-23	29mm (1.14in)	33mm (1.30in)	14mm (0.55in)	0.014kg
PA01-37	45mm (1.77in)	32mm (1.26in)	12mm (0.47in)	0.028kg
PA01-37R	45mm (1.77in)	37mm (1.45in)	12mm (0.47in)	0.026kg
PA01-37R Kabel	45mm (1.77in)	40mm (1.57in)	12mm (0.47in)	0.030kg
PA01-48	58mm (2.28in)	32mm (1.26in)	14mm (0.55in)	0.056kg
PA01-48R	58mm (2.28in)	32mm (1.26in)	14mm (0.55in)	0.050kg

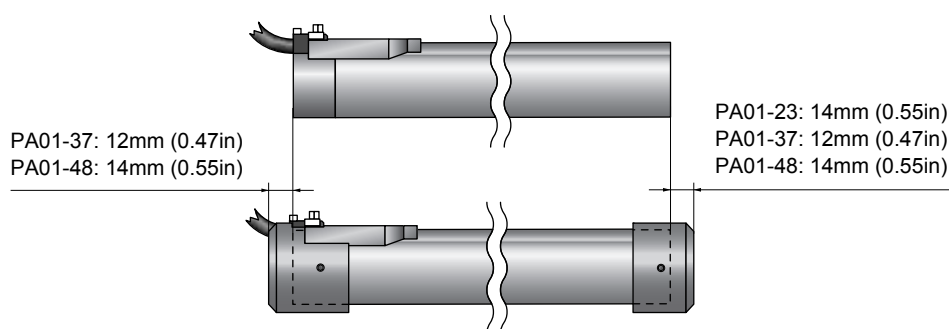

Item	Description	Part Number
PA01-23/12-F	Wiper for PS01-23x... (front wiper)	0150-3125
PA01-37/19-F	Wiper for PS01-37x... (front wiper for high clearance sliders)	0150-3225
PA01-37/19-R	Wiper for PS01-37x...(-C rear wiper for high clearance sliders)	0150-3226
PA01-37/19-R cable	Wiper for PS01-37x... (cable rear wiper for high clearance sliders)	0150-3227
PA01-37/20-F	Wiper for PS01-37x... (front wiper)	0150-3126
PA01-37/20-R	Wiper for PS01-37x...(-C rear wiper)	0150-3201
PA01-37/20-R cable	Wiper for PS01-37x...(-cable rear wiper)	0150-3221
PA01-48/27-F	Wiper for PS01-48x... (front wiper for high clearance sliders)	0150-3228
PA01-48/27-R	Wiper for PS01-48x...(-C rear wiper for high clearance sliders)	0150-3229
PA01-48/28-F	Wiper for PS01-48x... (front wiper)	0150-3127
PA01-48/28-R	Wiper for PS01-48x...(-C rear wiper)	0150-3202

External Position Sensor

Non-contacting measuring position sensors, using magnets with integrated processing electronics and differential encoder outputs for the E1100 series Servo Drives.

Together with the MB01-1000 magnetic band, the MS01/D position sensor is part of a high-resolution, robust, linear measurement system.

Features:

- Simple installation, by sticking on the magnetic band
- IP67 protection class, not sensitive to dust, moisture, or dirt
- Status display with LEDs directly at the sensor head
- Highest precision - Resolution 0.001mm - System accuracy $\pm 0.01\text{mm}$.
- Allows high travel speeds of up to 3 m/s
- Compatible with the E1100 series of LinMot Servo Drives.

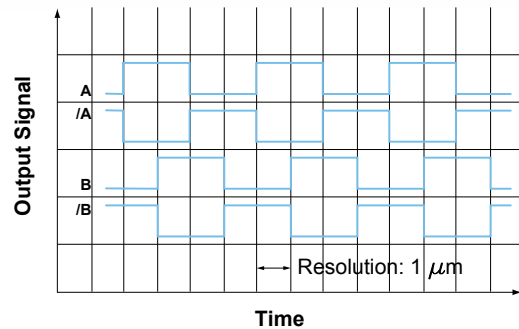

Counting direction

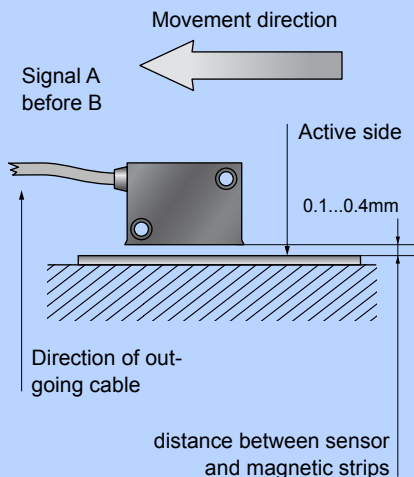

Installation

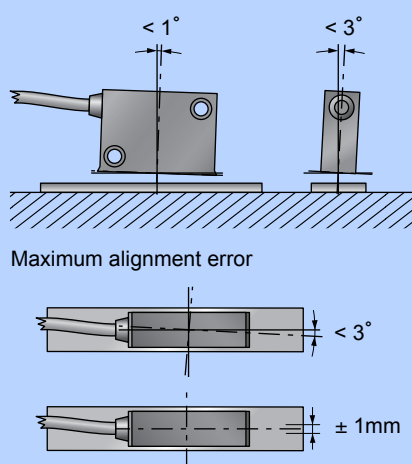

Minimum distance from slider

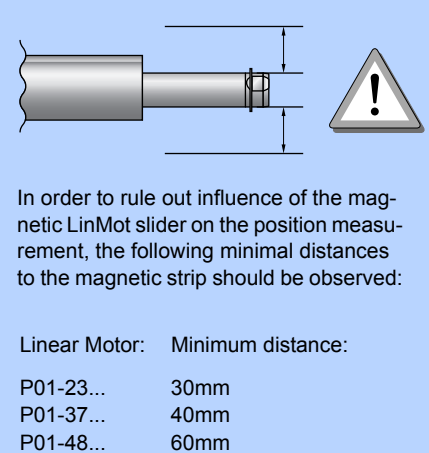

Dimensions

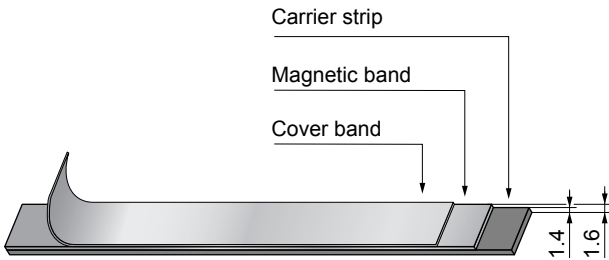
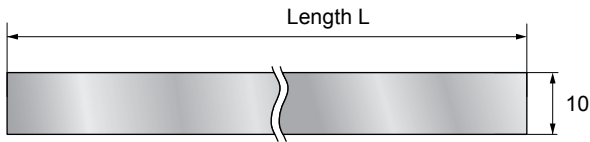
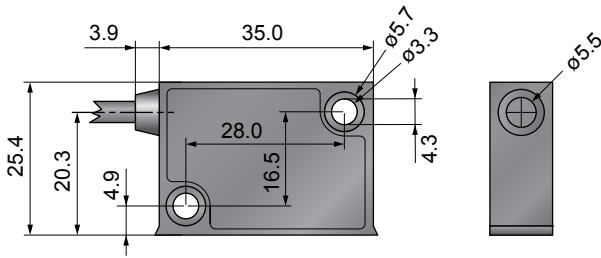

Cables

Cable length	2m, High Flex, PUR
Connector type	Dsub-9 (male)

Connector wiring

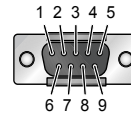

Pin 1	+5VDC
Pin 2	Channel /A
Pin 3	Channel /B
Pin 5	GND
Pin 6	Channel A
Pin 7	Channel B
Pin 4, 8, 9	n.c.

Technical data magnetic band

Order length	maximal stroke +3.0cm
Width	10mm
Carrier material	spring steel band
Precision class	$\pm 10 \mu\text{m/m}$
Temperature coefficient	$(11 \pm 1) \times 10^{-6} / ^\circ\text{K}$
Storage temperature range	-20...70°C
Storage temperature range	-40...70°C
Protection class	IP 67
Mounting	self adhesive magnetic band

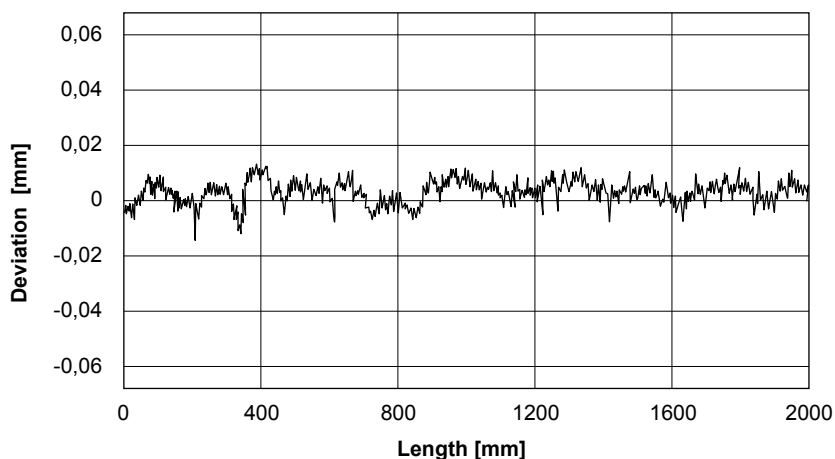

Ordering information

Item	Description	Part Number
MS01-1/D	Magnet sensor 1 μm , A/B (for 1mm magnetic band)	0150-1840
MB01-1000	Magnetic band, 1mm pole partitioning (per cm)	0150-1963
KS025-D/D-Encoder	Encoder Cable, High Flex (Length in m)	0150-3166
KS025-D/D15-Encoder	Encoder Cable, High Flex (Length in m)	0150-3168

Switched-Mode Power Supplies



Switched-Mode Power Supplies								
		24V		48V			72V	
Output voltage								
Output power		150W	300 W	150 W	300 W	600 W	300W	600W
Input Specification								
Input voltage range	[VAC]	93...123 / 187...264						
Input frequency	[Hz]	47...63						
Input current at full load (230V)	[A]	1.6	2.9	1.6	2.9	5.0	2.9	5.0
Input current at full load (115V)	[A]	2.7	4.9	2.7	4.9	7.0	4.9	7.0
Maximum Inrush current (230V)	[A]	70	70	70	70	80	70	80
Internal fuse	[AT]	4	6.3	4	6.3	12	6.3	12
Output Specification								
Output voltage range	[VDC]	24...28		48...52			72...76	
Output current	[ADC]	6	12	3	6	12	4	8
Hold up time at full load	[ms]	30						
Over voltage protection	[% Uout]	140						
General Specification								
Operating temperature range		-25°C...70°C						
Power reduction above 50°C		2% / °C						
Storage temperature		-25°C...85°C						
Humidity		95% rel. H max.						
Switching frequency		67kHz typ.						
Efficiency		>85%						
Output voltage indicator		LED						
Isolation input - output		3'000 VAC (1 minute)						
Isolation input - case		2'000 VAC (1 minute)						
Isolation output - case		500 VAC (1 minute)						
Safety class (IEC 536)		Class 1						
Safety standards meets		IEC950 EN60950 CEs for SELV						
Conducted EMI according to		EN55022 Class B EN55011 Class B FCC-B						
Electromagnetic susceptibility EMC		EN61000-4-2 4kV / 8kV EN61000-4-3 10V / m EN61000-4-4 2kV EN61000-4-6 10V EN61000-4-8 30A / m						
Case / Protection class		Steel / IP20						
Mounting		DIN rail TS35, EN50022						

150 W

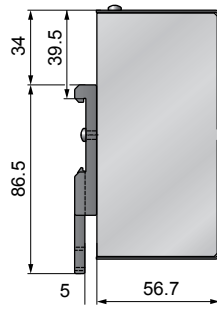
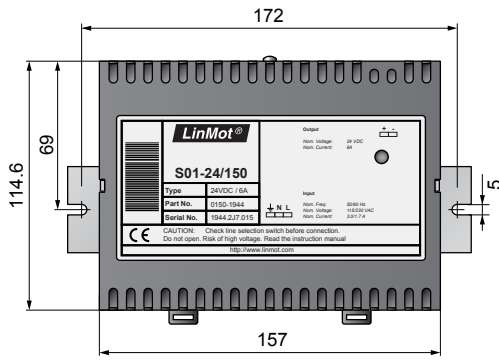

Option: Art. No. 0150-3039

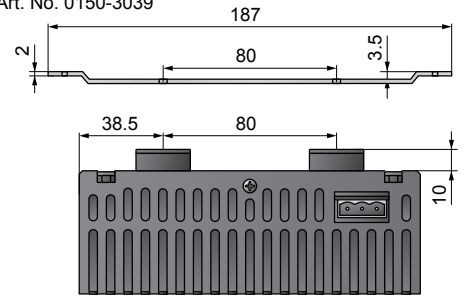

Weight: 800g

Item	Description	Part Number
S01-24/150	Switched-Mode Power Supply 24V/150W	0150-1944
S01-48/150	Switched-Mode Power Supply 48V/150W for E100/E200	0150-1940

300 W

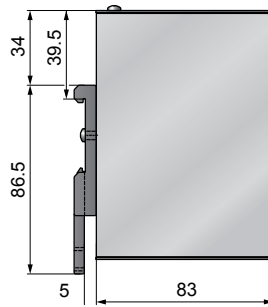
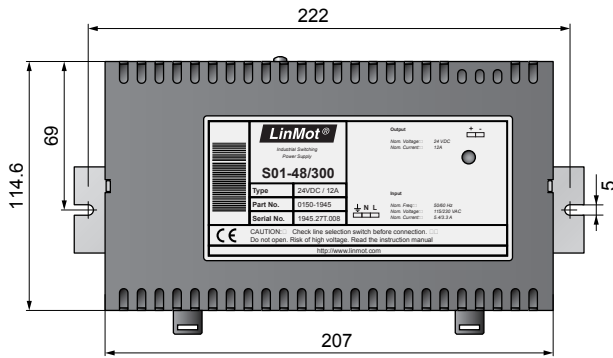

Option: Art. No. 0150-3040

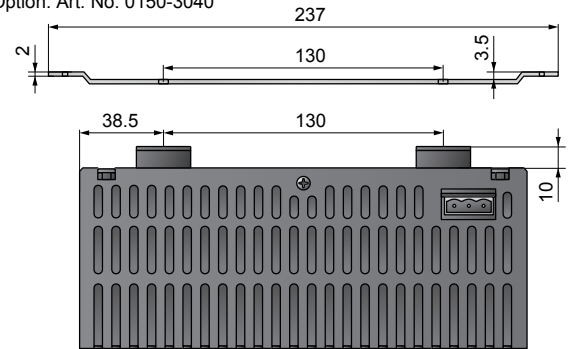

Weight: 1400g

Item	Description	Part Number
S01-24/300	Switched-Mode Power Supply 24V/300W	0150-1945
S01-48/300	Switched-Mode Power Supply 48V/300W for E400	0150-1941
S01-72/300	Switched-Mode Power Supply 72V/300W for E1001/E2001E4001	0150-1942

600 W

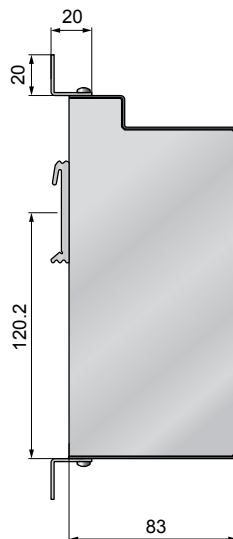
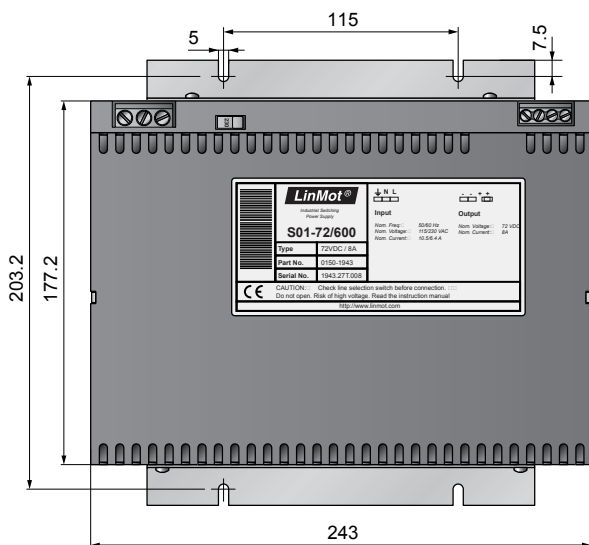

Option: Art. No. 0150-3041

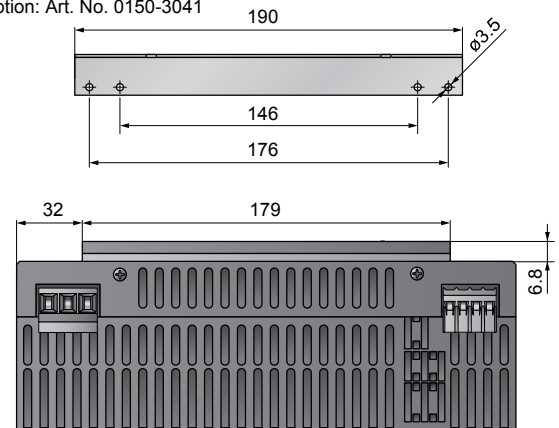

Weight: 2000g

Dimensions in mm

Item	Description	Part Number
S01-48/600	Switched-Mode Power Supply 48V/600W	0150-1946
S01-72/600	Switched-Mode Power Supply 72V/600W for E4001	0150-1943

Switched-Mode Power Supplies 72V



Power Supplies	S01-72/500	S01-72/1000
Input		
Input voltage range	93...123VAC / 187...264VAC automatical switchover	AC 3 x 340...550V
Power frequency	50...60Hz	50...60Hz
Efficiency	typ. 88%	typ. 91.5%
Input current limitation	=< 70A _{peak} typ. cold, =< 150A _{peak} hot	< 35A _{peak} typ. in cold state, < 70A _{peak} in hot state
Internal fuse	16ATH/250VAC	3x6.3A
External fuse		intern 3 x 6.3AT, external fuse with 16A to max. 32A necessary (C,D,K)
Output		
Preset range Vo	54 - 80VDC, factory setting: 72VDC ± 0.5%	56 - 80VDC, factory setting: 72VDC ± 0,15/0,2V
Max. Outputpower	480W	1000W
Powerboost	max. 150% (see chart)	max. 190-210% (see chart)
Start-up delay	< 1,5s (bei 230VAC)	250 ms typ.
Rise time	40 / 50 / 80ms typ.	20ms typ., 155ms typ. at 50.000 iF load
Back feeding voltage	up to 100VDC	up to 100VDC
Parallel connection	yes (max. 3 identical power supplies)	yes (max. 3 identical power supplies)
Regulation		
Line regulation	< 0.2% for Vo at Vi _{min} - Vi _{max}	< 0.3% for Vi _{min} - Vi _{max}
Load regulation	< 0.5% for Vo at Io 0 - 100% Boost-M. < 3.0% for Vo at Io 0 - 100% Parallel-M.	< 0.5% for Vo at Io 0 - 100% single operation < 3% for Vo at Io 0 - 100% parallel operation
Response time	typ. 1ms at Io 20 - 80%	1 ms typ. at Io 20 - 80%
Protection and Controlling		
Overtemperature protection	Switches off if inside temperature becomes to high, reconnection with hysteresis	Switches off if inside temperature becomes to high, reconnection with hysteresis
Safety/Standards		
	IEC 60950 / EN 60950 / VDE 0805 IP20, safety class 1, pollution degree 2 UL508/UL60950	EN 60950 / VDE 0805 / VDE 113 safety class I / VDE 0100 / IP20 CSA-C22.2 No 107 / CSA-C22.2 No. 60950-1-03 UL Std. 60950-1 / UL Std. 508 (Operation in Delta mains only for UL508) pollution degree 2
EMC		
Mains feedback / PFC	EN 61000-3-2 Class A only with ext. PFC 12mH/4,5A/230VAC	
Interference immunity	EN 61000-6-2 / EN 61000-4-2 / EN 61000-4-3	EN 61000-6-2 / EN61204-3
Flicker	EN 61000-3-3	EN 61000-3-3
ESD	EN 61000-4-2 8/15kV	EN 61000-4-2 8/15 kV
Electrical fields	EN 61000-4-3 noise level 10V/m (Krit. A)	EN 61000-4-3 noise level 10V/m
Burst	EN 61000-4-4 4kV (Krit.A)	input: EN 61000-4-4 4 kV Ausgang: EN 61000-4-4 2 kV
Surge	EN 61000-4-5 4/2kV (Krit.A)	input: EN 61000-4-5 2/4 kV output: EN 61000-4-5 0,5 kV
HF Immunity	EN 61000-4-6 noise level 10V (Krit.A)	EN 61000-4-6 noise level 10V
Voltage drop	EN 61000-4-11	EN 61000-4-11
Interference emission	EN 61000-6-4 EN 55011 Klasse B, Radiation depends on assembly	EN 61000-6-3 / EN61204-3 EN 55022 / EN 55011 class B, Radiation depends on assembly
Operating Data		
Temperature range	-25°C...70°C integral, temperature controlled fan, air intake bottom-up	-25...+70°C integral, temperature controlled fan, air intake bottom-up
Derating	3% / K at +60°C (see chart)	2% / K at +60°C
Weight	1.0kg	2.0 kg
	Operation in any assembly position possible. The distance between the surrounding components and the air admission and air exit holes should be at least 20 mm.	Operation in any assembly position possible. The distance between the surrounding components and the air admission and air exit holes should be at least 50 mm
Mechanics		
Assembly	All systems can be snapped onto a symmetrical 35mm DIN-rail	The power supply can be directly screwed onto the wall.

Current limiting characteristics (typ.)

S01-72/500

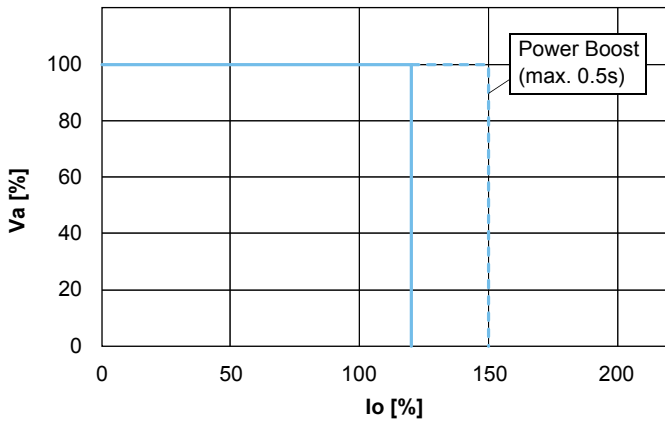

Boost 500ms up to 150% I_{nom} possible, after that min. 500ms break necessary

Current limiting characteristics (typ.)

S01-72/1000

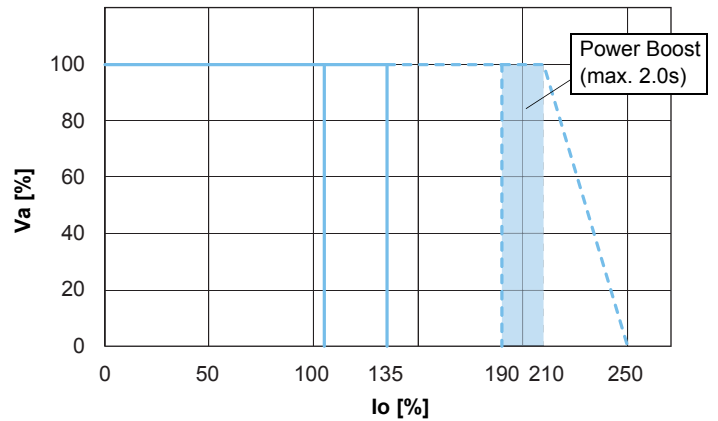

no boostbreak necessary, but the boosttime in the last 4s mustn't be longer a 2s, otherwise a boostbreak 1min is necessary (boostbreak <25ms will be not recognized)

Dimensions

S01-72/500

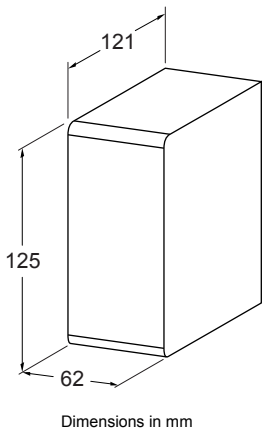

Dimensions in mm

Operation in any assembly position possible. The distance between the surrounding components and the air admission and air exit holes should be at least 20 mm. Please ensure that exhaust air is not immediately sucked in again.

Dimensions

S01-72/1000

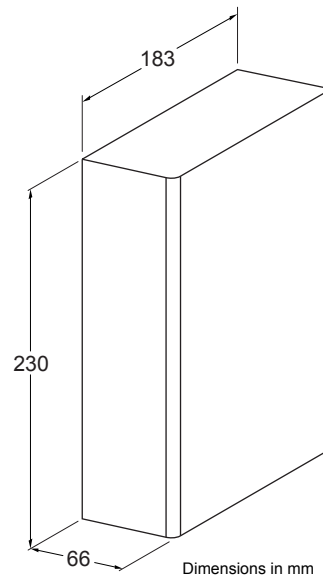

Dimensions in mm

Operation in any assembly position possible. The distance between the surrounding components and the air admission and air exit holes should be at least 50 mm. Please ensure that exhaust air is not immediately sucked in again.

Bestellinformationen

Artikel	Beschreibung	Artikelnummer
S01-72/500	Switched-Mode Power Supply 72V/500W	0150-1874
S01-72/1000	Switched-Mode Power Supply 72V/1000W	0150-1872

Transformer Supplies

Type T01 in modern industrial design, meets national, and international upcoming regulations. It was designed bearing following aspects in mind:

- ✓ 3 power classes:
420VA
900VA
1500VA
- ✓ 3 input voltage versions:
3x230VAC
3x400VAC
3x480VAC
- ✓ optimal layout to reduce surface area
- ✓ simple mounting via open-ended slot
- ✓ compact construction and low weight



T01-...-Multi

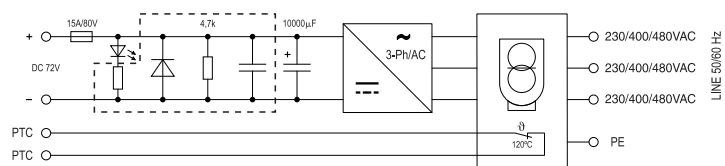

Use T01 only as Motor supplies for LinMot Servo Drives series E1100/B1100 and E1001. Do not use T01 supplies with series E100 or series E1000 Servo Drives!

Technical Data

3-Phase Transformer Supply with integrated rectifier bridge, LGD, PTC, DC-Link buffer capacitor and Output Fuse, output ripple 2%.

Test Voltage between Primary and Secondary Winding 4467V, 50Hz.

Maximum Power Dissipation:
45W(420VA)
75W(900VA)
110W(1500VA)

Suitable for Installation up to protection rating IP 20, insulation class E, max. ambient temperature 40°C.

Input and Output Voltage

Input:

T01-...-Multi 3x230/400/480 VAC, 50/60Hz

External Fuse: 2AT(420VA), 4AT(900VA), 8AT(1500VA)

Output:

T01-72/420 72 VDC, 5.8A (100%ED), 10A (35%ED), 15A (15%ED)

T01-72/900 72 VDC, 12A (100%ED), 20A (35%ED), 30A (15%ED)

T01-72/1500 72 VDC, 20A (100%ED), 33A (35%ED), 50A (15%ED)

Single Phase Transformer Supply

The T01-72/420-1ph is a single phase version with 208/220/230/240VAC 50/60Hz input voltage and 420VA output power.

The mechanical dimensions of the T01-72/420-1ph are the same as the three phase transformer supply with 900VA output power.

420 VA

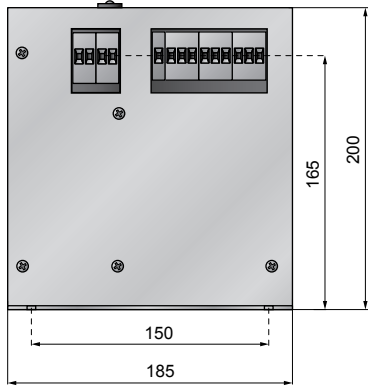

Weight: 6.6kg

Dimensions in mm

Item	Description	Part Number
T01-72/420-Multi	Transformer Supply 3x230/400/480 VAC, 50/60Hz, 420VA	0150-1869
T01-72/420-1ph	Transformer Supply 1x208/220/230/240VAC, 50/60Hz, 420VA*	0150-1859

*Dimensions see 900VA-Supply

900 VA

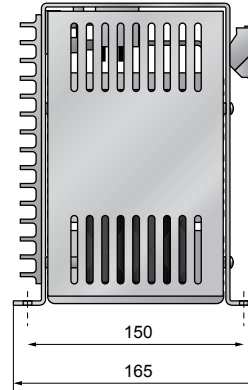
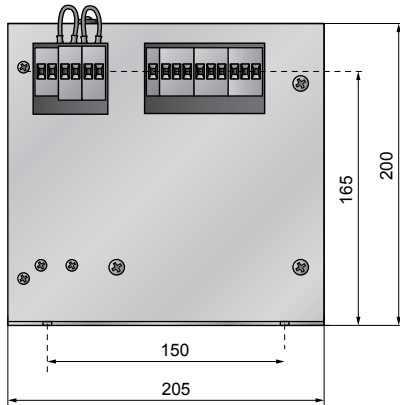

Weight: 10.6kg

Dimensions in mm

Item	Description	Part Number
T01-72/900-Multi	Transformer Supply 3x230/400/480 VAC, 50/60Hz, 900VA	0150-1870

1500 VA

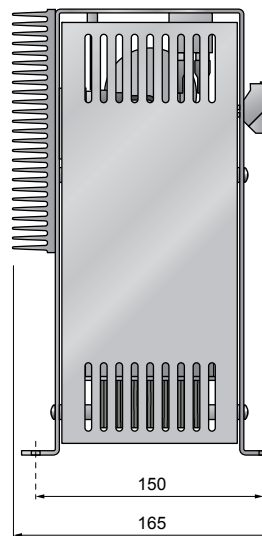
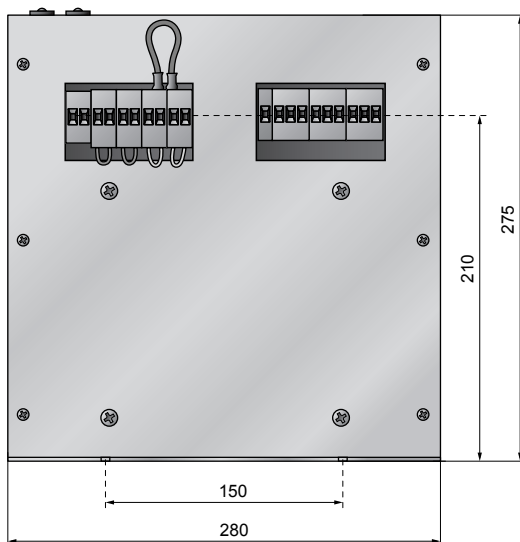

Weight: 17kg

Dimensions in mm

Item	Description	Part Number
T01-72/1500-Multi	Transformer Supply 3x230/400/480 VAC, 50/60Hz, 1500VA	0150-1871

Regeneration Resistor

The brake resistor is high-amperage and has a very high electric strength. It also features high pulse inhibition. Its compact form factor and the design of the connection elements make it easier to attach and install the resistor elements. Complete encapsulation provides protection from dirt and accidental contact with the high-voltage components.

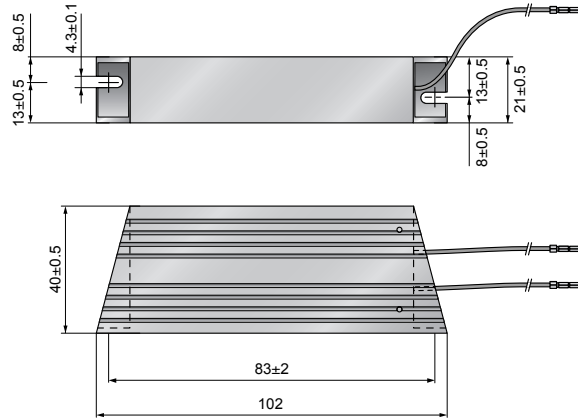

Connector Cable and Converter

Pre-assembled RS232 cable and USB converters for the connection between drive and PC for drive configuration with LinMot Talk.

RJ45 patch cable for fast CAN, RS485 and master encoder wiring on E1100 Servo Drive connectors X7/8 and X10/11.



Item	Description	Part Number
RR01-10/60	Regeneration Resistor 60W for E1100	0150-3088

Item	Description	Part Number
RS232 PC config. cabel 2m	for E100/E1001	0150-3009
RS232 PC config. cabel 2m	for E100/E1001/E1100/B1100	0150-3307
RS232 PC config. cabel 2.5m	for E1200/E1400	0150-2143
USB-Serial Converter	USB to 9-pin Serial Converter	0150-3110
USB-CAN Converter	USB to CAN Converter for E1100	0150-3134
RJ45-08/0.3	RJ45 patch cable 0.3m for E1100	0150-1852
RJ45-08/0.6	RJ45 crossover patch cable 0.6m	0150-1853
RJ45/RJ45-0,2-ML1	MC-Link cable 0,2m	0150-3308

Configuration Interface

Servo Drive series E100/E1001 use the RS232 interface for configuration. If the RS232 interface is used for communication with the overlaid control, configuration and debugging may be done over the RS485 Interface.

Servo Drive series E1100 may be configured over RS232 or CAN Interface. Configuration over CAN bus permits multi axes configuration. The CAN bus is also used for configuration and debugging if the serial interface RS232/RS485 is occupied by the communication to the overlaid control.

USB-RS232 Converter

As many new PC's and Laptops do not have an RS232 interface any more and many available USB-RS232 converters are giving comatibility problems, LinMot has it's own converter. The necessary drivers are installed automatically together with the LinMot Talk software.

The USB-RS232 converter may be used for drive configuration on the series E100/E1001 and series E1100 drives with a PC's without RS232 interface.

USB-CAN Converter

The USB-CAN converter is used with the series E1100 drives for multi axes configuration or configuration, debugging an optimization if the serial interface RS232 or RS485 is used for communication with the overlaid control.

Control Box B01-4
for E100/1000
Drive



Control Box
B01-E1100 for
E1100 Drive



Control Box

The B01-4 Control Box allows the user to start up the LinMot system quickly. The box is used with the AT and MT Servo Drives. It allows manual setting of control signals for the Servo Drive, using a potentiometer and buttons, and is primarily intended for testing.

The B01-1100 Control Box allows the user to start up the LinMot an E1100 system quickly. It allows manual setting of control signals for the Servo Drive and is primarily intended for startup and testing.

Item	Description	Part Number
B01-4 230V / 50HZ	Control Box for E100/E1001 Drive (230VAC)	0150-1930
B01-4 115V / 60HZ	Control Box for E100/E1001 Drive (115VAC)	0150-1931
B01-E1100	Control Box for E1100 Drive	0150-1970
B01-B1100	Control Box for B1100 Drive	0150-2110

Control Box

The Control Boxes provide the following functionalities:

- Starting and stopping program sequences
- Initialization
- Analog position targets using potentiometer
- Setting trigger signals
- External setting of trigger signals and position values
- Status message display

B01-4

The scope of delivery includes:

- 1 Control Box, LinMot® B01-4
- 1 Plug-in power supply 230V / 50Hz and 115V / 60Hz
- 2 Connector cables: 'Control Box'-Servo Drive

B01-E1100/B1100

The scope of delivery includes:

- 1 Control Box, LinMot® B01-E1100 or B01-B1100
- 2 Connector cables: 'Control Box'-Servo Drive

Design Notes 538

Safety Notes 548

ASCII Commands E100/E1001 552

Motion Commands E1100 553

Technology Functions 556

Controlling rotary motors 558

CE-Declaration 561

Product Index 568

Terms and Conditions 576

Correct Installation

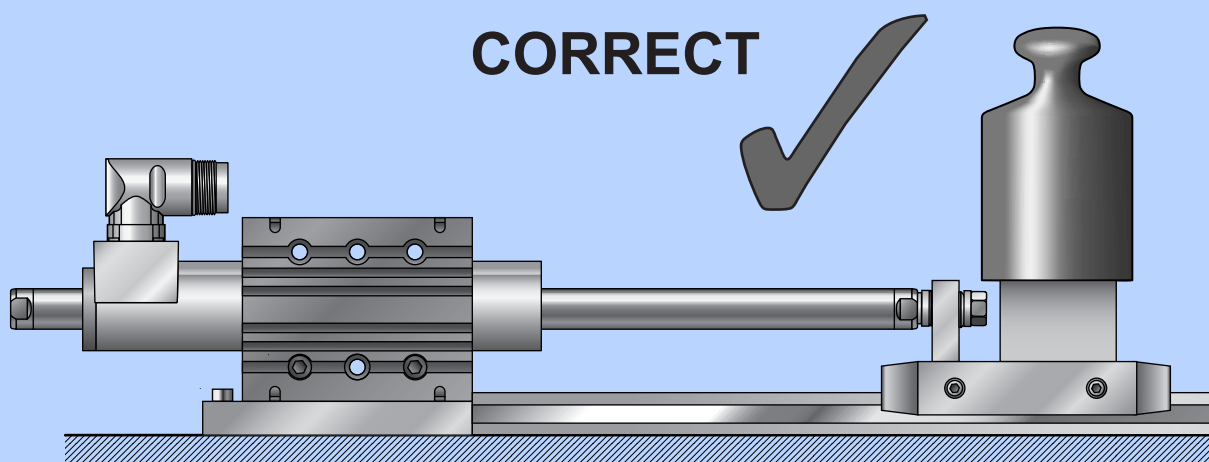

In order to ensure long life for the linear motor, the load to be positioned is mounted on a linear bearing. This external bearing mount prevents excessive load on the slider guide integrated in the stator. The external linear bearing is selected based on the load and environmental conditions.

Avoid side loads on the slider

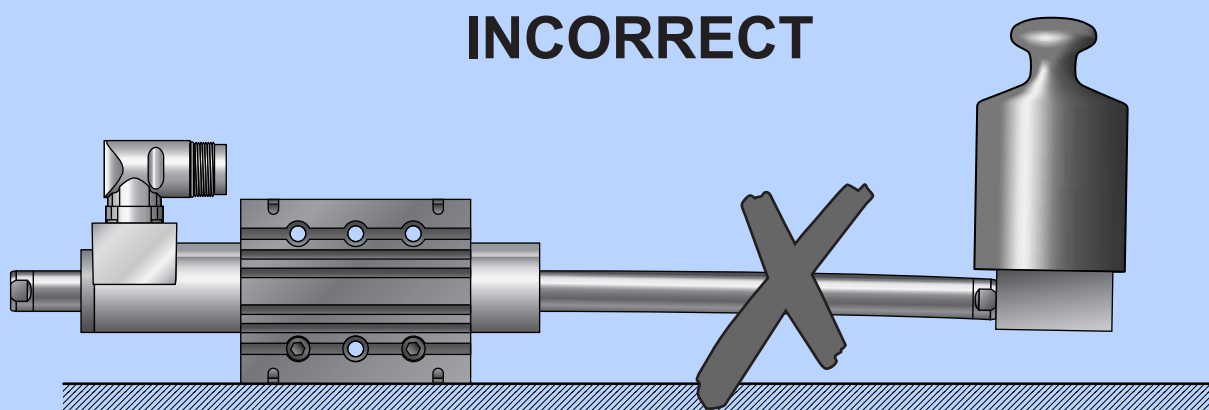

If the load is attached directly to the linear motor without any guide, then the side loads generated can lead to wear of the stator and slider, which reduces the life of the motor. The integrated stator bearing is primarily designed to guide the slider, and should not be subjected to additional loads transverse to the direction of motion. The slider should also be loaded only in the direction of motion.

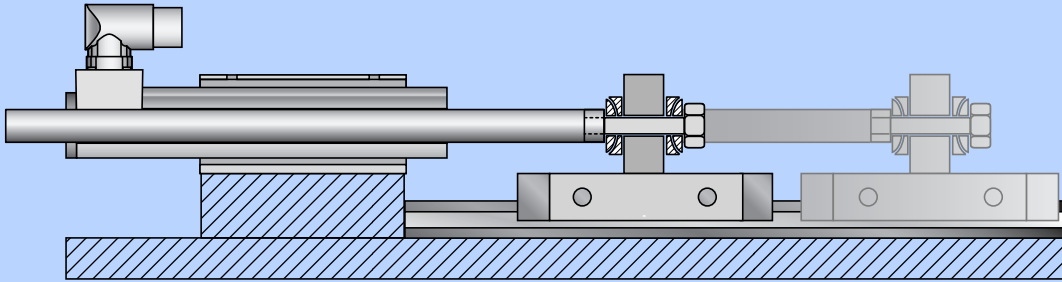
“Moving Slider” Installation

The slider of the linear motor is guided in the stator, and the load is mounted on a linear bearing. To simplify installation and avoid alignment errors, the load is attached with a fixed bearing, consisting of a rounded washer and a bevel washer.

Installation Accessories:

- Stator mounting motor flange, see Page 518
- Slider mounting fixed bearing, see Page 522

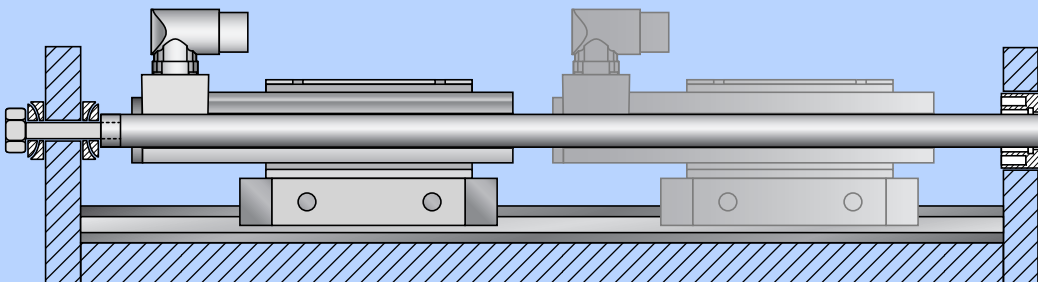
“Moving Stator” Installation

The stator of the linear motor and the load are mounted on linear bearings. To avoid binding, the slider is attached with a fixed bearing at one end and a floating bearing at the other.

Mounting Accessories:

- Stator mounting motor flange, see Page 518
- Slider mounting kit, see Page 522

Stator Mountings

The linear motor stators are mounted in a clamp flange.

Matching clamp flanges are available for each family of motors, with the designation PF. These ensure simple installation and optimum cooling of the linear motor. The flange can be mounted horizontally by the through-holes, or vertically using T-nuts and the T-slot.

Integrated cooling fins, or even forced-air cooling with a ventilator, can increase the continuous force of the linear motor even further.

If needed, stators can also be integrated into the design using customer-specific clamp flanges. Care must be taken that the stator is mounted with as much surface contact as possible, in order to provide optimum cooling of the motor.

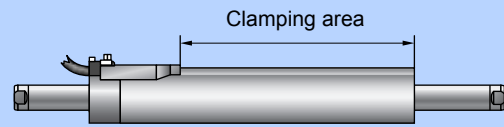

Correct: Large contact surface area guarantees optimum cooling of the linear motor.



LinMot flange with optional fan to increase continuous force



Incorrect: Small mounting surface area prevents proper cooling of the linear motor.

Load Mounting

LinMot sliders are precision components, designed to bear very large motor forces in the direction of motion. Forces acting transverse to the direction of motion, as well as torques, are to be avoided in installation and operation.

Correct Installation: In order to prevent torque loads on the slider, the wrench and allen key are used at the same end of the slider during installation.



Incorrect: The tools used to attach the load must not be used on opposite ends of the slider. Avoid subjecting the slider to torque loads.



Clamp flange with mounting holes and side slot

With a through bore and milled slot on one side, the stator can be mounted relatively easily. The lengthwise key on the motor fits into the milled slot. It also serves to clamp the stator.

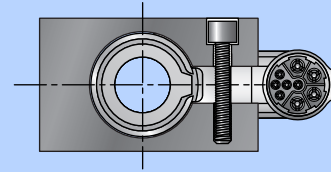

Clamping flange with two asymmetrical holes

Using two asymmetrical bores and a small slit to clamp the motor, the stator is mounted inside the flange.

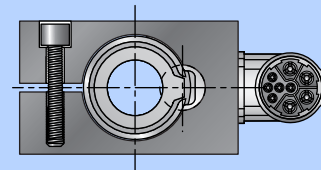

Mounting with clamping cylinders

The LinMot H01 and B01 guides hold the stator in a closed hollow profile using clamping cylinders. In order to ensure even clamping loads over the stator length, between two and five clamping cylinders, depending on the size of the linear motor, must be used along the entire length of the stator.

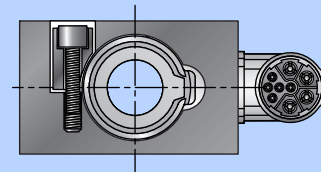

Two-piece Design

Another possibility is to make the motor flange in two parts. The two half rounds and the slot for the stator can be milled into the open halves from above.

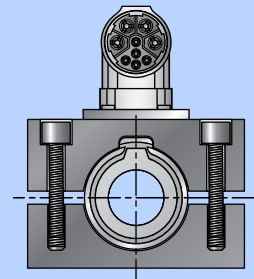

Hollow profile with clamping tube

A clamp mount with a round bore and a clamping tube segment, as shown in the adjacent drawing, is easy to manufacture. Clamping is provided either by a side slit or with clamping screws that compress the tube segment.

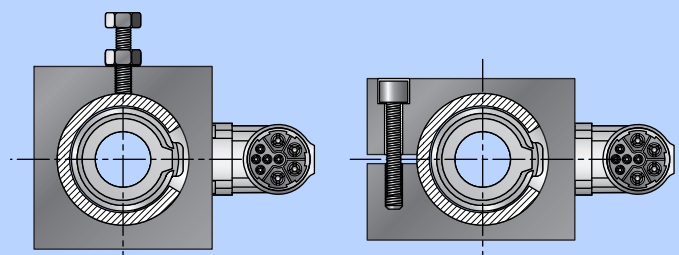

Moving Motor Cables

For designs with moving stators, guidance of the cables must be given particular attention. The motor cables are often forgotten when designing drive modules, and then have to be somehow inserted into a finished design. This often causes difficulty maintaining the required bend radii.

Cable guidance should therefore be given the proper attention, from the beginning of the design, for applications with moving motor cables. Cable radii should be kept as large as possible to ensure long life. The minimum prescribed bend radius should never be exceeded.

For service purposes, the moving cable sections should be designed with cable-chain or robot cables, with as short a length as possible, and with plug connectors on both ends (see illustration.) The motor cable can then be replaced quickly and easily when service is needed. For this reason, it is recommended that applications with moving motor cables use connector type stators.

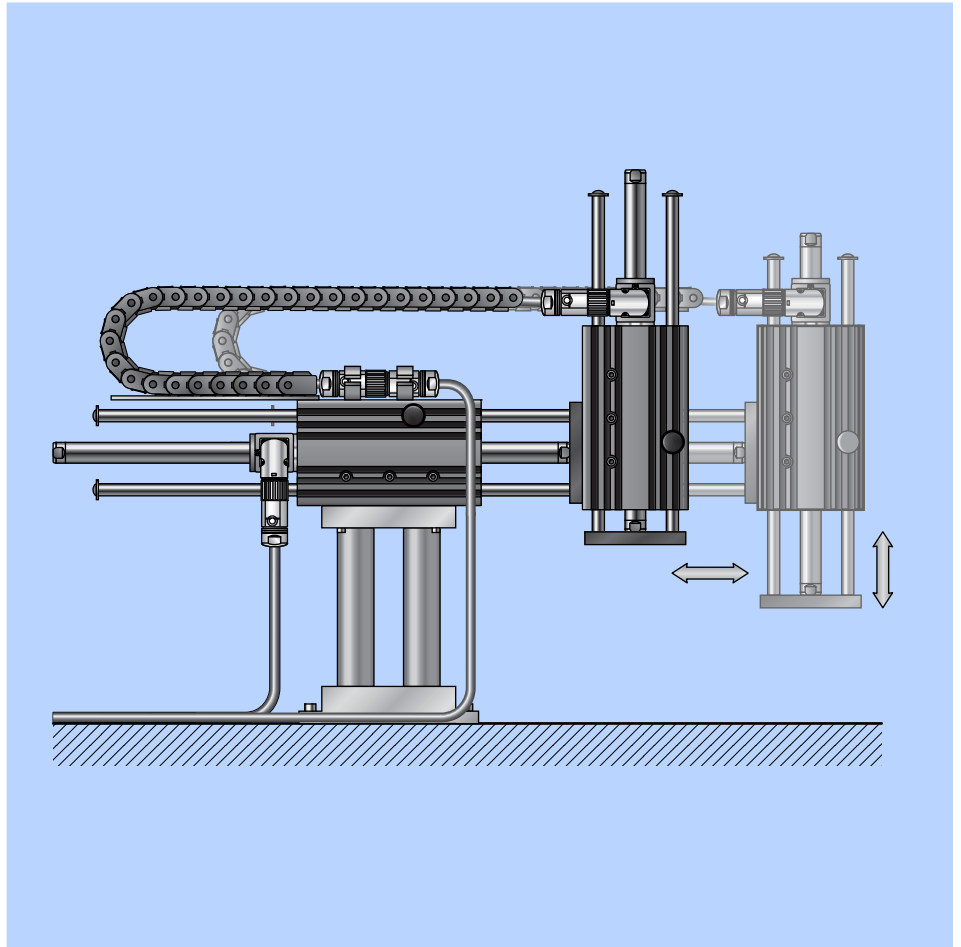

LinMot provides a large selection of pre-assembled motor cables in standard lengths from stock.

All motor cables are available in any desired length, in the three versions of standard, high-flex, and robot cables.

For LinMot motor cables, see Page 508

Standar Cable

The standard motor cable is suitable only for connections in which the cable is fixed. The cable attached to the cable-type stator must also be installed in a fixed location and must not move.

High-Flex Cable

High-flex motor cables are suitable for installation in cable chains (rolling up, no torsion). For long life, the minimum bend radius must not be exceeded, and should be kept as large as possible. High-Flex cable comes without cable track.

Robot Cable

The robot cable is used if the motor cable will be subjected to torsion, as is typically the case with moving cable sleeves. In addition to torsion, robot cables can also be subjected to rolling-up motion.

Cable Mounting

For stators with direct cable exits, special attention must be paid to ensure that the motor cable is not damaged by exceeding the minimum prescribed bend radius. In no case can the motor cable be kinked at the stator (or anywhere else).

For applications with a moving stator or moving linear motor, care must also be taken that the motor cable does not move due to constant acceleration and deceleration.

The cable attached to the cable-type stator must not move. It is not suitable for installation in cable chains or moving cable conduit.

In applications with moving motor cables, wherever possible, stators with plug connectors should be used. These allow a motor cable of the desired quality to be plugged directly into the stator. A motor cable installed in this manner can be replaced, if needed, without a problem.

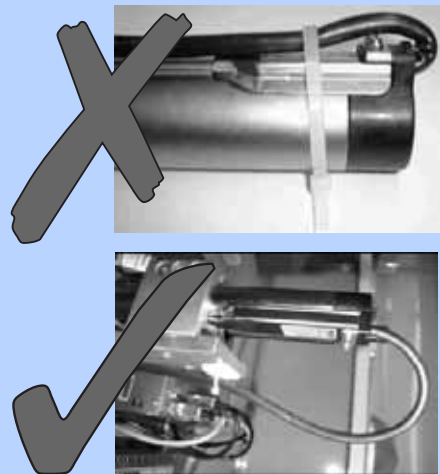

Mounting clip for IP67 plug

Cable-type stators with IP67 plugs are shipped with two mounting clips for attaching the "flying IP67 plug connector." Primarily in applications where strong vibrations or motions occur, the plug connection must be secured in order to prevent damage to the motor cable due to vibrations.

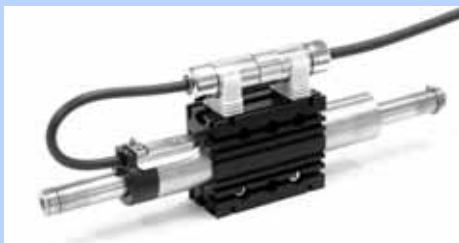

In applications with moving motor cables, wherever possible, connector type stators should be used (see above)..

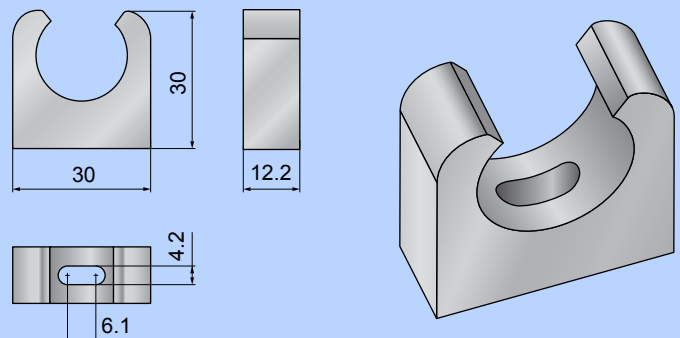

PS02-23Sx80 Stator with ribbon cable

Stators of type PS02-23Sx80 are connected directly via a 13-conductor ribbon cable. This is connected directly to the ZIF plug integrated in the stator.



In order to prevent damage to the stator, the ribbon cable must never be plugged in or unplugged while the Servo Drive is powered.

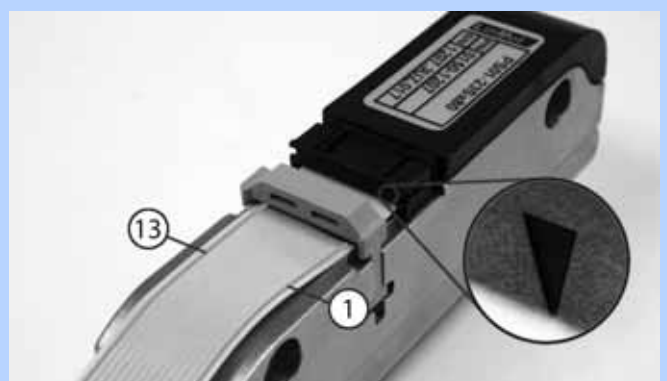

Minimum distance from slider

When installing linear motors in modules with metal parts near the slider, undesired forces can arise due to magnetic attraction or eddy currents. These generally manifest as erratic and jerky positioning, or reduced dynamics of the linear motor.

In order to avoid this, minimum distances between the slider and any metal parts are to be observed whenever metal materials are used nearby

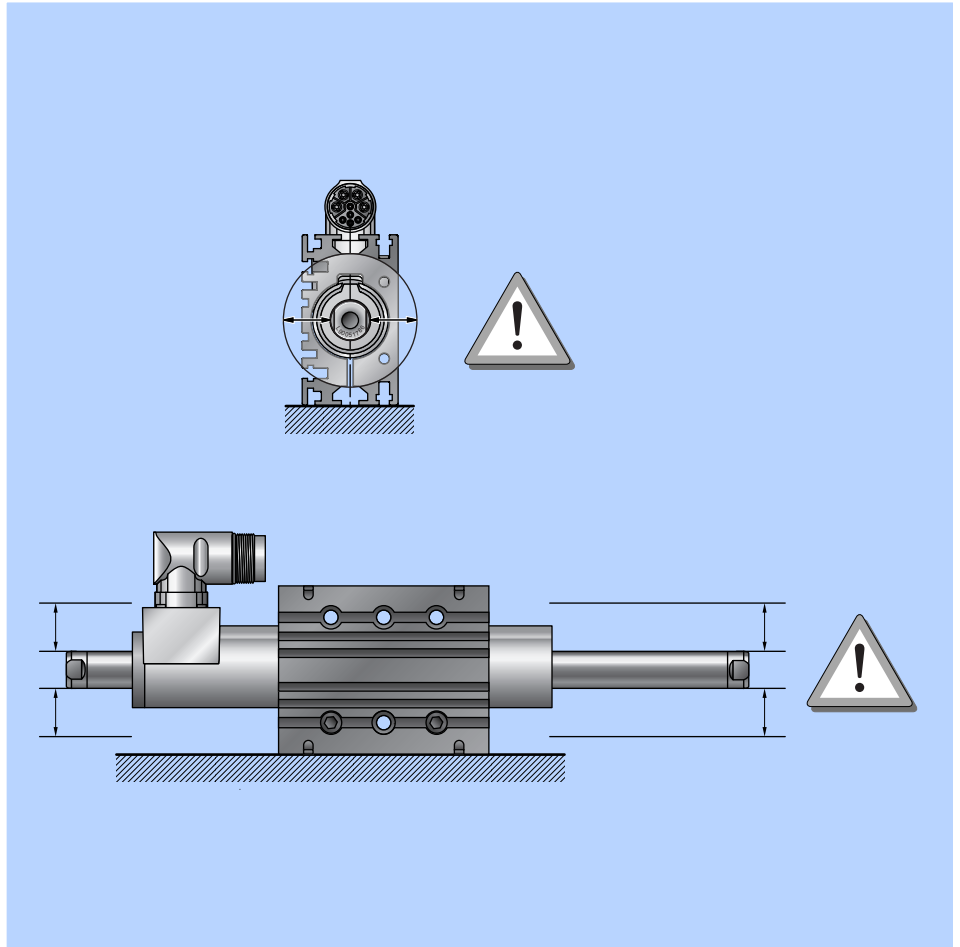

Minimum distance from slider surface to ferromagnetic parts (iron, steel, etc.):

Linear Motor series P01-23: 10mm

Linear Motor series P01-37: 15mm

Linear Motor series P01-48: 20mm

Minimum distance from slider surface to non-ferromagnetic parts (aluminum, bronze, stainless steel, etc.):

Linear Motor series P01-23: 5mm

Linear Motor series P01-37: 7mm

Linear Motor series P01-48: 10mm

Magnetic Fields

In order to achieve very high power density in the linear motor, very strong neodymium magnets are normally used. These generate very strong magnetic fields at a distance of a few mm, in order to obtain the highest motor forces possible.

Due to their cylindrical shape, the magnetic fields of LinMot linear motors drop off quickly with increasing distance from the slider surface. The earth's magnetic field is already stronger than the magnetic field generated by the linear motor at a distance of 3x the slider diameter.

Magnetic Attraction

Magnetic attraction between ferromagnetic materials, such as iron or steel, and the magnetic slider, is based on reluctance force.

Distances less than the minimum can lead to erratic motion, overshooting, and excessive heating of the linear motor.

In general, the minimum distance to the slider surface must be maintained, regardless of whether the ferromagnetic part moves with slider, or the slider moves past the part.

Eddy Currents

If the slider moves very close to fixed, non-ferromagnetic metal parts, such as aluminum, bronze, stainless steel, etc, then the slider is decelerated by the eddy currents induced in the metals.

This deceleration limits the dynamics of the linear motor and leads to severe heating of the stator.

For this reason, a minimum distance must also be observed for designs with non-ferromagnetic parts.

Magnetic fields

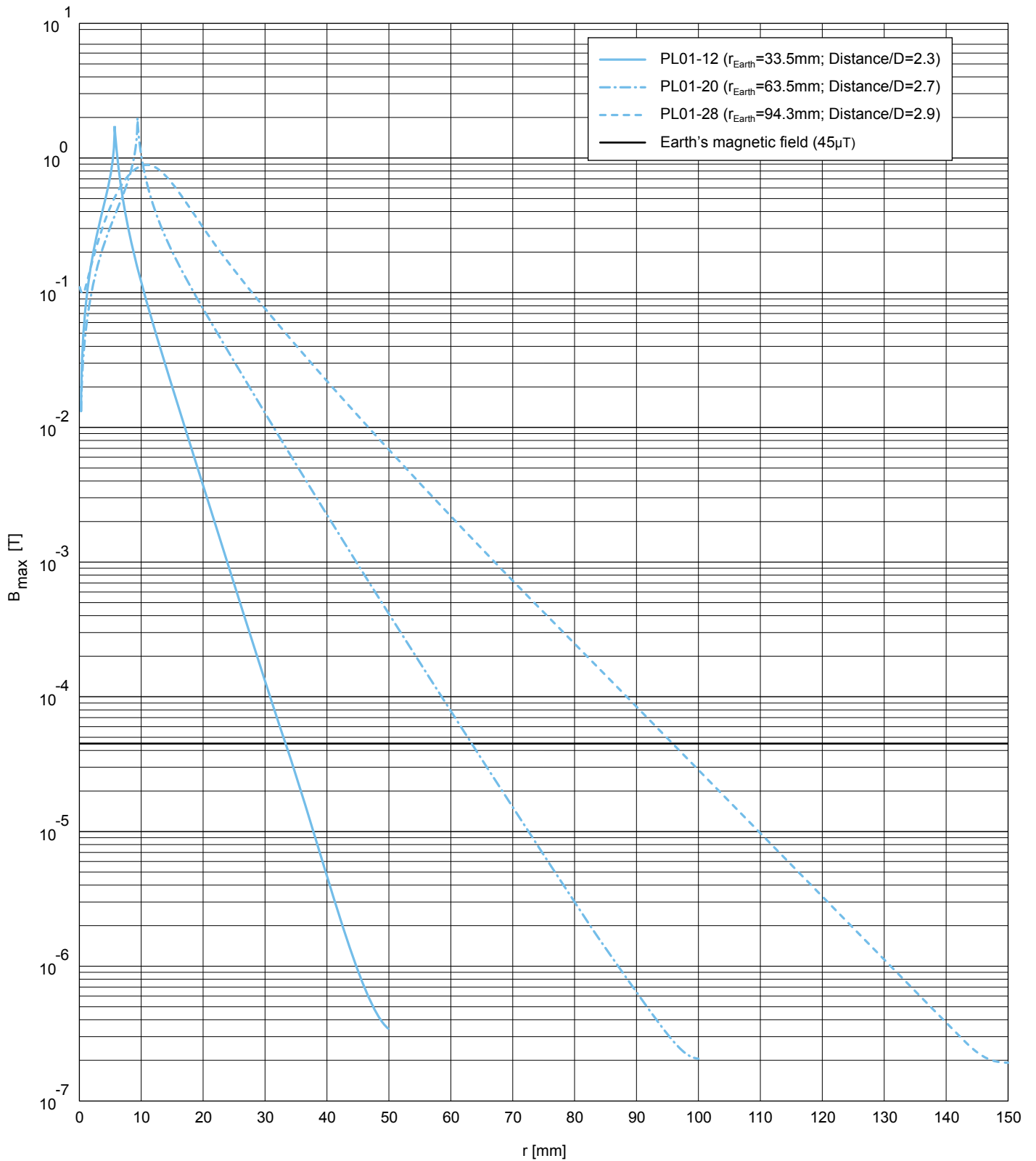

At a distance of 28mm, 54mm, or 91mm from the slider surface, the magnetic induction from the earth's magnetic field is already stronger than the magnetic induction from the LinMot slider. This distance is no more than three times the slider diameter.

Vertical Installation

Vertically mounted linear axes have the negative aspect that the drive must compensate for the force of gravity, both during the motion and when stopped. Part of the motor force is therefore required to hold the load mass in place. Asymmetrical forces also arise under acceleration, depending on the direction of motion. Less force is needed for acceleration in a downward direction than for upward motion, where the force of gravity must also be applied. This leads to asymmetrical load ratios, which make optimal control more difficult. All of these effects occur regardless of whether a linear motor or a rotary servomotor is used as the drive.

If the force of gravity is compensated for, then the drive only has to provide the dynamic force necessary to move the load during acceleration and deceleration, and the load ratios do not depend on the direction of motion.

In this section, three different methods for compensating for gravity are presented:

1. MagSpring magnetic springs
2. Mechanical Springs
3. Pneumatic cylinders

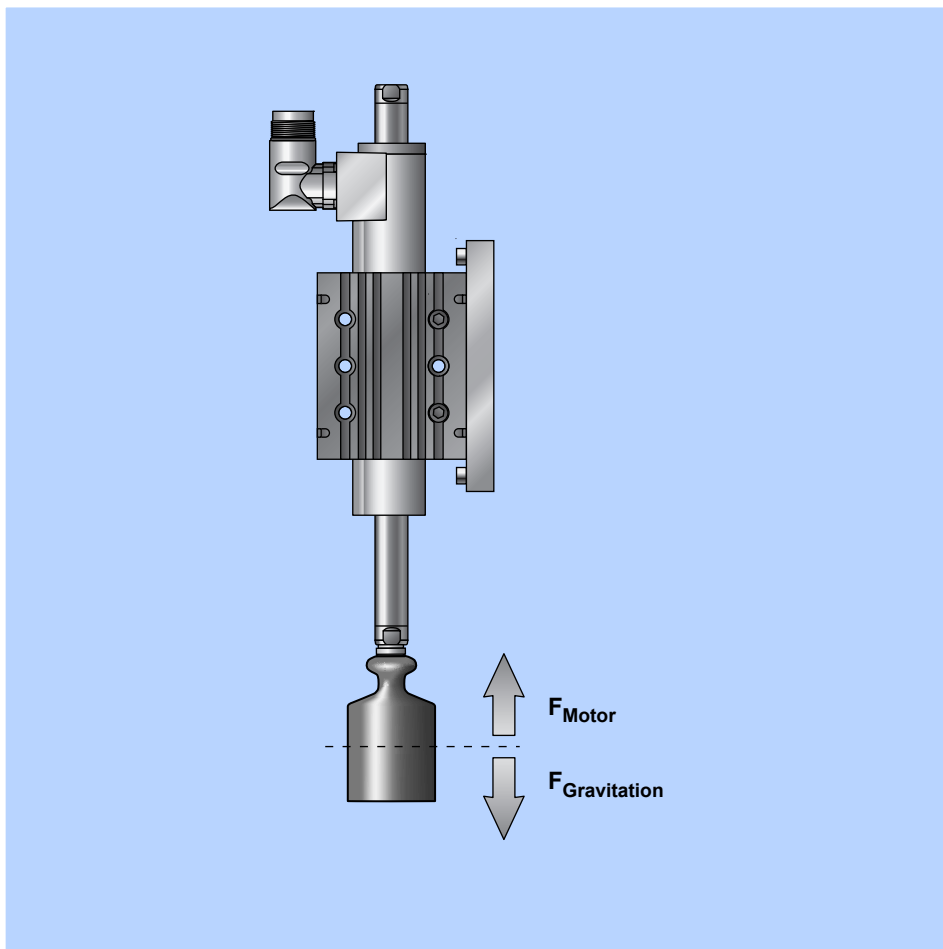

MagSpring Magnetic Spring

Weight compensation using magnetic springs is very close to the ideal method of compensating for the force of gravity.

MagSpring generates a constant force over its entire stroke range, regardless of position, speed, or mounting orientation. MagSpring is also a purely passive design element that does not require any external energy source.

MagSpring magnetic springs are available with forces up to 60N and a maximum stroke of 275mm.

For MagSpring Products, see Page 467

Mechanical Spring

The mechanical spring is a very inexpensive design element for providing weight compensation in vertical installations. The linear increase in force over the stroke range, however, does not allow for ideal compensation of gravity over the entire stroke.

If mechanical springs are used as force compensation, then compression springs or extension springs with an appropriate end component (see graphic, right) should be used for longer lifespan. Extension springs with mounting loops bent onto the ends are not suitable.

Pneumatic Cylinders

Constant high forces can be applied over a long stroke range using a pneumatic cylinder. If the pneumatic cylinder is used to compensate for the force of gravity, it is connected directly to the compressed air supply without a control valve. If an additional pressure reducing valve is installed between the air supply and the cylinder, then the force can be adjusted continuously.

Important:

In order to prevent the cylinder from building up an air cushion during downward motion, a rapid vent valve must be installed as close as possible to the air connector to allow air to escape during downward motion.

Weight compensation: Setup for downward motion

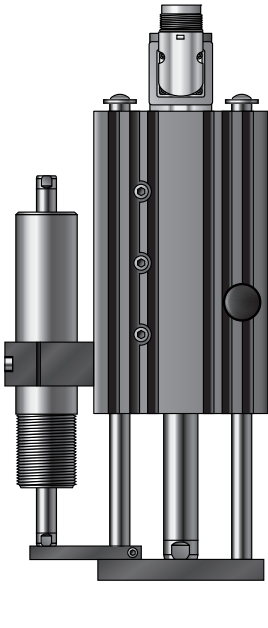

Weight compensation with MagSpring mounted on the side



Weight compensation with mechanical spring

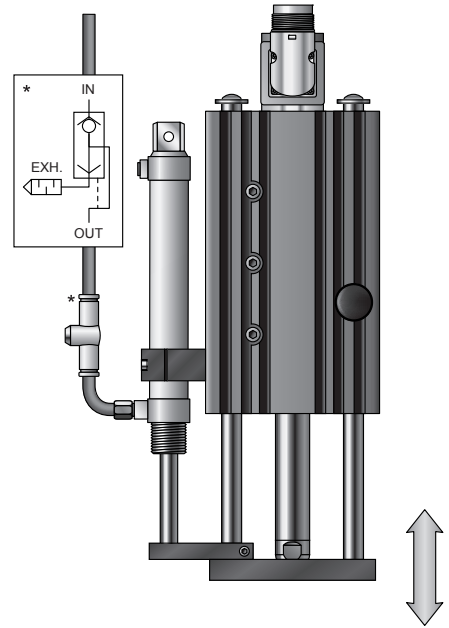

Weight compensation with pneumatic cylinder and rapid vent valve

Weight compensation: Setup for upward motion



Weight compensation with MagSpring mounted on the side



Weight compensation with mechanical spring

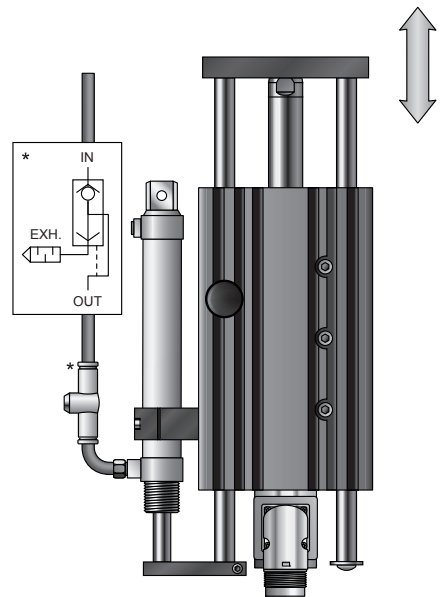

Weight compensation with pneumatic cylinder and rapid vent valve

Working with LinMot sliders

Liability

NTI AG, as owner of the LinMot and MagSpring brand names, disclaims liability for any damages caused by improper handling of magnetic sliders. By purchasing LinMot products, you confirm that you have read and understood the following warnings. Provide these safety notes to your customer if you resell LinMot products. Inform your customers and employees of the potential hazards.



LinMot Sliders

LinMot and MagSpring sliders are precision components that must be handled with due care. The slider consists of a thin-walled stainless steel tube in which very strong neodymium magnets are mounted. An uncontrolled collision between two sliders, or a slider and a ferrous component (caused by magnetic attraction) can damage the surface of the slider. A damaged slider surface can lead to severe wear and reduced lifespan of the motor.



Pinching

LinMot sliders can exert an enormous force when they are brought close enough to each other. Be very careful, especially when handling large sliders, and keep them away from other sliders, magnets, or ferrous components. Keep the slider in the original packaging prior to final installation, or after removal from a machine. Keep unpacked sliders away from untrained persons.



Magnetism

NdFeB-Magnets are much stronger than "typical" magnets. Keep them a good, safe distance away from any devices or objects that can be damaged by magnetism. This includes: televisions and computer monitors, credit cards and check cards, computers, diskettes and other data media, videotapes, mechanical clocks, hearing aids, and speakers.

Pacemakers can be affected by large magnets - be absolutely sure to keep enough distance.



Brittleness, splinter hazard

The NdFeB magnets used in LinMot sliders are not made of metal, but are made by sintering, and therefore can break. For this reason, LinMot sliders should be handled with care, and, as much as possible, never allowed to "bang" against each other or against other ferrous parts. It is also possible that magnetic splinters could break off from damaged sliders. When handling damaged sliders, therefore, gloves and safety glasses should be worn.



No work done on sliders

LinMot sliders are available in set lengths, and are attached via internal threads on the end, or by clamping around their ends. In no case should you attempt to saw, drill, or otherwise work on the slider. Not only will the slider magnets break, but the drill dust generated is also slightly flammable. Keep the LinMot slider away from open flame and heat, to avoid damaging the drive magnets with excessive temperatures.



Effects on humans

Whether permanent magnets can affect the human organism is a point of dispute. Therapists who use magnets for healing would agree with this, but scientific experiments show that the fields of permanent magnets (electromagnets are a separate case) are too weak to have any measurable effect on humans. Whether long-term exposure to permanent magnets is good or bad for the health is not relevant for LinMot sliders, since the slider's magnetic field is already weaker than the earth's magnetic field at a distance of 90mm (see Page 545).



Safety of machines

Linear motors are machinery components that are designed for use in electrical systems or machines. During operation, these machinery components have moving parts and hot surfaces, which bear a risk of severe injury or material damages.

Those responsible for the safety of the system or machine must ensure, in order to prevent personal injury and property damage, that only qualified personnel who are familiar with working on electrical drive systems work on the devices.

Qualified personnel are persons who, based on their education, experience, and instruction, as well as their knowledge of applicable standards, agreements, accident prevention regulations, and operating relationships, have been authorized by those responsible for the safety of the system to carry out any required activities, and are therefore able to recognize and avoid potential hazards.

No claim of completeness is made for these safety notes. For questions and problems, please contact LinMot.

Startup

Startup (beginning normal operations) of the linear motor is not allowed until the machine meets the applicable safety regulations.

Operating instructions and other documents or product documentation are to be followed thoroughly for all associated work. In particular, it must be noted that the sliders on linear motors can move at extremely high accelerations, and that hazardous situations can arise.

Electrical Installation

Only tested, electrically insulated power supplies can be used with LinMot Servo Drives and accessories.

Electronic devices are fundamentally not fail-safe. The user is therefore responsible for ensuring that the linear motor is brought to a safe condition if a device fails.

Electrical installation is to be carried out in accordance with application regulations.

Any documentation information that is more strict is to be observed.

Moving machine parts

In particular, it must be noted that the sliders on linear motors can move at extremely high accelerations and speeds, and that hazardous situations can arise.

Safe drive control

Linear motors have become an integral part of modern drive technology. Many drives on machines lead to hazardous motions, from which people must be protected during manual intervention. Safety functions, such as "safe stop", have been defined for this purpose, which can be implemented both with external components and with integrated safety functions.

For the "safe stop" safety function, the energy supply to the drive must be safely interrupted. The drive must not be able to generate any force, and therefore no hazardous motions. The stop position does not need to be monitored. Force-guided contact separation from the energy source can be used, but is not necessary.

In this section, two concepts for implementing the "safe stop" safety function are presented:

1. Interrupting the motor supply
2. Safe pulse inhibitor

Depending on the requirements for implementation of a safe stop, a combination of measures, as well as additional fault recognition, may be necessary.

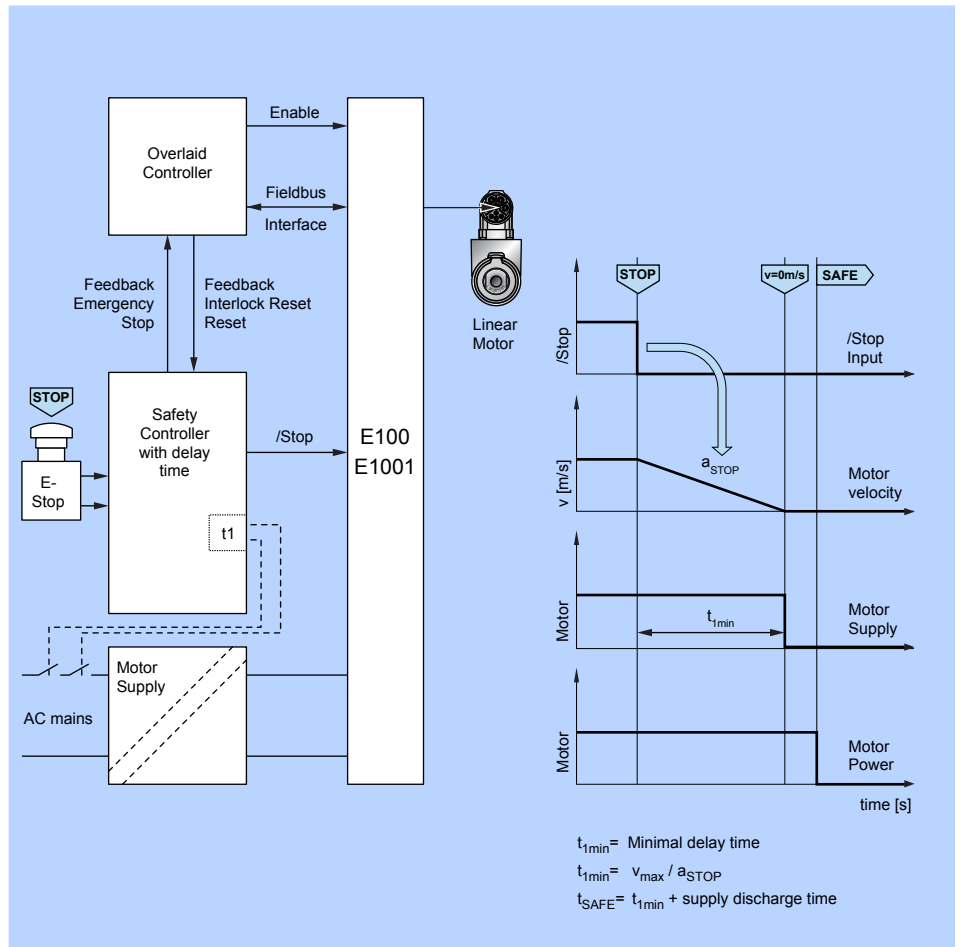

Interrupting the motor supply

If the Servo Drive does not have an integrated safety function (pulse inhibitor), then the safety function must be provided by disconnecting the power supply of the linear motor, using external components. This is done using grid contactors. Note that the energy stored in the capacitors can cause a delay.

The time between initiation of the E-stop command or tripping of a safety device and stopping the drive is defined as the ramp-down time. The maximum tolerable ramp-down time is listed in the standards for special machines (e.g., presses) or must be determined in a hazard analysis.

Machine Directives

According to the European directive 98/37/EG (machine directive), the manufacturer of a machine is required to perform a risk analysis in order to determine all risks associated with his machine. The machine is to be designed and built in accordance with this analysis. Risks should ideally be mitigated by design features. Only if that is not possible are protective measures to be provided for the remaining risks.

The design of the machine must ensure that the machine can be properly operated without hazards to personnel.

Independent Motor Supply

LinMot Servo Drives have two independent power supplies for logic and motor supply. In case of emergency, only the motor supply is interrupted, so that the linear motor comes to a stop, due to a lack of power, and cannot produce any more force.

The logic supply is not interrupted in an emergency, so that the linear motor does not need to be referenced again when it is restarted. Even if the linear motor is moved while it is not powered, the position is not lost, as long as the logic supply is not interrupted.

Controlled Braking

In certain applications, rapid stopping of the drive with a brake is necessary. Upon E-stop, the Servo Drive receives a command to execute a fast stop. After a time delay (after motion has stopped), the drive is separated from the power supply.

Important: Braking itself is not a primary safety function. It does, however, contribute to safety, and serves to dissipate kinetic energy. A risk analysis must determine whether faulty behavior can be tolerated in the specific application

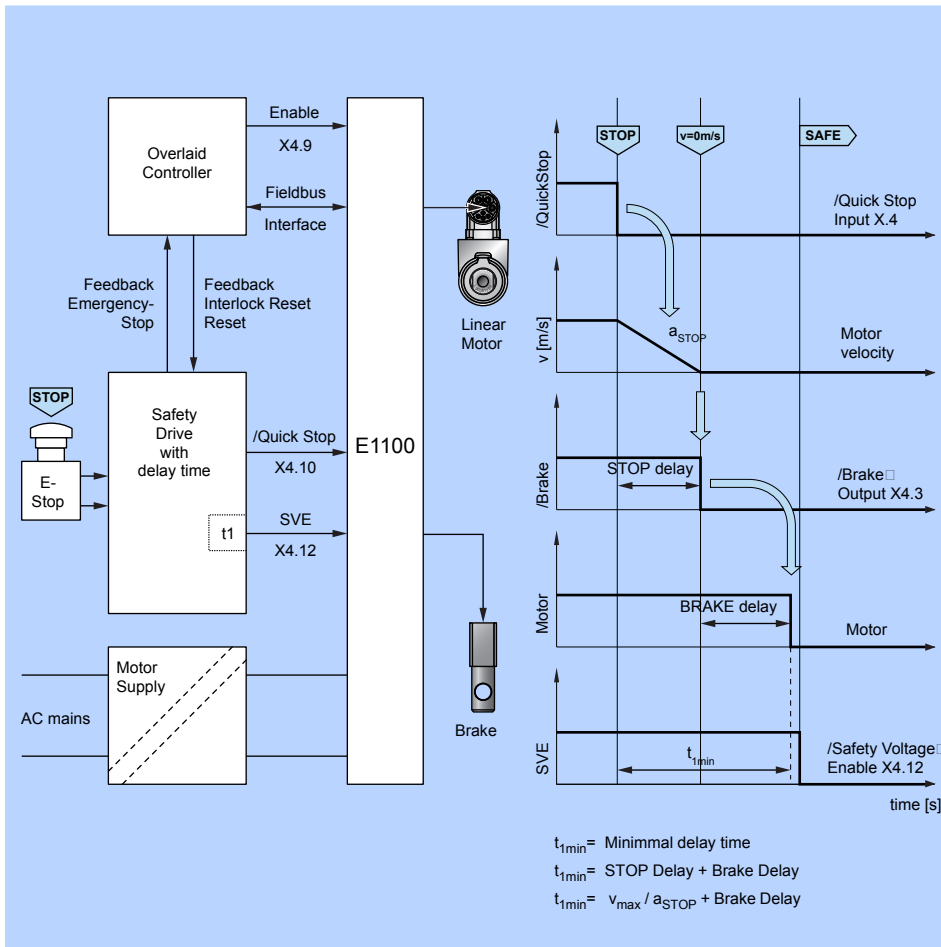

Shutdown in case of emergency

In order to be able to shut down a machine or system immediately in case of emergency, the emergency stop function must be available at all times, in all operating modes. The fastest shutdown of a machine is obtained with a controlled shutdown by the drive drive. This is equivalent to a Category 1 stop, as defined in DIN EN60204-1. For emergency shutdown, energy must be completely switched off using electromechanical means.

For typical Servo Drives, this can be done using grid contactors, which are controlled by a contactor with a time delay contact. The time delay is set such that a controlled shutdown is just completed beforehand (see figure on opposite page).

For Servo Drives with integrated safety, the "safe stop" safety function is available, which is achieved with a pulse inhibitor (see left figure).

The advantage of this concept is the fastest possible shutdown. A disadvantage is the possibility of a significantly longer stop period in case of a fault, if, for example, the Servo Drive does not brake, and may accelerate, and runs freely without braking once the drive power is cut off. A risk analysis must determine whether this faulty behavior can be tolerated in the specific application.

Safety Voltage Enable

The LinMot Series E1100 Servo Drives with fieldbus interfaces incorporate the integrate safety function of a safety voltage enable to accomplish the "safe stop" function per EN954-1. The above diagram shows a wiring suggestion for implementing a Category 3 "safe stop" per EN954-1, with controlled shutdown (Stop 1 per DIN EN60204-1).

As soon as the pulse enable is inhibited by the SVE signal, the final stage of the power supply is safely switched off without any delay. The pulse enable is provided as an external terminal.

The Servo Drive divides it into two independent signals internally. The external wiring must be done in such a way as to prevent shorting to other current-carrying components.

No claim of completeness is made for these safety notes. For questions and problems, please contact LinMot.

Brake actuation

LinMot E1100 Series Servo Drives have an output to actuate a mechanical brake, which mechanically locks the linear axis if the motor is switched off. This can prevent the switched-off motor from being shifted from its current position.

Important: Braking controls themselves are not a primary safety function. It does, however, contribute to safety, and serves to prevent undesired shifting of the de-powered motor. A risk analysis must determine whether faulty behavior can be tolerated in the specific application

Vertical Axes

Operation of vertical axes presents special problems. Shutting off the drive power in case of a drive fault or loss of power leads to an unsafe condition, and can cause loads to fall down.

This must be taken into consideration when planning emergency shutdowns (E-stops). Typically, independent mechanical brakes (approved for use as safety brakes) actuate in these cases, but sometimes additional external measures are required to monitor their functionality.

Acceptance testing at start-up

For each drive drive, the system behavior is matched to the current application using adjustable parameters.

For example, the maximum permissible speed or time behavior during a stop can be set in this manner.

Regardless of whether the safety function is used with drives with integrated safety, or with the use of external devices, the settings must be checked in the course of an acceptance test during startup. Using this acceptance test, errors in parameterization are discovered.

ASCII Commands E100/E1001

ASCII Command						
	Value / Command	Write command	Read command	LinMot	System	
Write commands	Increment set position	!IP	-	•		
	Increment set position on next trigger	!TI	-	•		
	Goto setposition on next trigger	!TP	-	•		
	Start curve	!RC	-	•		
	Start curve on next trigger	!TC	-	•		
	Start cyclic curve	!CC	-	•		
	Start cyclic curve on next trigger	!CT	-	•		
	Stop cyclic curve	!CS	-	•		
	Move reference position	!MH	-	•		
	Defien new set position	!RP	-	•		
	Setze internen Positionszähler auf den Wert 0	!ZD	-	•		
Read/Write commands	Set position	!SP	!GD	•		
	FF acceleration	!DA	!EA	•		
	FF deceleration	!DB	!EB	•		
	FF Friction	!DF	!EF	•		
	P-Value position controller	!DP	!EP	•		
	D-Value position controller	!DD	!ED	•		
	I-Value position controller	!DI	!EI	•		
	Maximum velocity	!SV	!GV	•		
	Maximum acceleration	!SA	!GA	•		
	Maximum motor current	!SC	!GC	•		
	Offset motor current	!DK	!GK	•		
	Curve amplitude	!DC	!EC	•		
	Curve offset	!DO	!EO	•		
	Curve velocity	!DS	!ES	•		
	Flag FREEZE	!SF	!GX	•	•	
	Flag INIT / Flag RUN / Flag STOP	!SI / !SR / !SS	!GX		•	
	Read commands	Actualmotor current	-	!AC	•	
		Actual position	-	!GP	•	
		Position resolution	-	!PI	•	
		Velocity resolution	-	!VI	•	
Accerleration resolution		-	!AI	•		
Motor current resolution		-	!CI		•	
State		-	!GS		•	
System error state		-	!GE		•	
System warning state		-	!GW		•	
Motor error state		-	!EE	•		
Motor warning state		-	!EW	•		
State flags		-	!EX		•	
Protocol version			!PV		•	

Commans structure

Byte	Value	Description
0	!'	Command header
1...2	char, char	Command
3...x	[char], ...	Argument
x+1	'\r' (0xD)	Commad end

Every command begins with an exclamation mark, followed by two characters coding the command, then the arguments and finally a carriage return symbol.

Acknowledge structure

Byte	Value	Description
0	'#'	Acknowledge header
1...x	char, ...	Acknowledge message
x+1	'\r' (0xD)	Acknowledge end

Every command received by the Servo Drive is acknowledged. A further command may be sent only if the last one has been acknowledged by the Servo Drive.

Example

Direction	ASCII-Sequence	Description
PC -> Servo Drive	'!SP2000A' + 0xD	Sets the set position of motor A to 2000 increments
Servo Drive -> PC	'#' + 0xD	If the Servo Drive sends back the symbol '#', the command was accepted and executed by the drive.

Motion Commands E1100/E1200/B1100/C1200

Run Modes	Applications
Motion Command Interface	Auto Start *
Triggered VA-Interpolator	Easy Steps
Triggered Time Curves	* Master Slave *
Command Table Mode	* Force Control *
Triggered Command Table	* Winding *
Position Indexing	Customized Application Software
Analog Position	
Triggered Analog Position	
CAM Mode	*
Triggered CAM Mode	*
VAI two Positions Continuous	
Continuous Curve	*

Control Word	Status Word	Warn Word
0 Switch On	Operation Enabled	Motor Hot Sensor
1 Voltage Enable	Switch On Active	Motor Short Time Overload
2 /Quick Stop	Enable Operation	Motor Supply Voltage Low
3 Enable Operation	Error	Motor Supply Voltage High
4 /Abort	Voltage Enable	Position Lag Always
5 /Freeze	/Quick Stop	Position Lag Standing
6 Go To Position	Switch on Locked	Drive Hot
7 Error Acknowledge	Warning	Motor Not Homed
8 Jog Move +	Event Handler Active	PTC 1 *
9 Jog Move -	Special Motion Active	PTC 2 *
10 Reserved	In Target Position	Regeneration calc. Hot
11 Home	Homed	Reserved
12 Clearance Check	Fatal Error	Reserved
13 Goto Initial Position	Motion Active	Reserved
14 Reserved	Position Band 1	Interface Warning
15 Phase Search	Position Band 2	Application Warning

Command		
Parameter Access & Control	Parameter 1	Parameter 2
Write Interface Control Word *	Interface Control Word	
Write Live Parameter	UPID (Unique Parameter ID)	Parameter Value
Write X4 Intf Outputs with Mask *	X4 Write Bit Mask	* X4 Write Bit Values *
Clear Event Evaluation *		
No Operation		

Velocity Acceleration Interpolated Positioning Commands	Parameter 1	Parameter 2	Parameter 3	Parameter 4	Parameter 5
Absolute VAI Go To Pos	Target Position	Maximal Velocity	Acceleration	Deceleration	
VAI Go To Pos After Actual Command	* Target Position	Maximal Velocity	Acceleration	Deceleration	
VAI Go To Pos From Act Pos Starting With Dem Vel = 0	Target Position	Maximal Velocity	Acceleration	Deceleration	
VAI Go To Pos From Act Pos And Act Vel	Target Position	Maximal Velocity	Acceleration	Deceleration	
VAI Dec=Acc Go To Pos	* Target Position	Maximal Velocity	Acceleration		
VAI Dec=Acc Go To Pos After Actual Command	* Target Position	Maximal Velocity	Acceleration		
VAI Dec=Acc Go To Pos From Act Pos Starting With Dem Vel = 0	* Target Position	Maximal Velocity	Acceleration		
VAI Dec=Acc Go To Pos From Act Pos And Act Vel	* Target Position	Maximal Velocity	Acceleration		
VAI Predef Acc Go To Pos	* Target Position	Maximal Velocity			
VAI Predef Acc Go To Pos After Actual Command	* Target Position	Maximal Velocity			
VAI Predef Acc Go To Pos From Act Pos Starting With Dem Vel = 0	* Target Position	Maximal Velocity			
VAI Predef Acc Go To Pos From Act Pos And Act Vel	* Target Position	Maximal Velocity			
Predef VAI Go To Pos	Target Position				
Predef VAI Go To Pos After Actual Command	* Target Position				
Predef VAI Go To Pos From Act Pos Starting with Dem Vel = 0	Target Position				
Predef VAI Go To Pos From Act Pos And Act Vel	Target Position				
Increment VAI Increment Act Pos	Position Increment	Maximal Velocity	Acceleration	Deceleration	
VAI Increment Act Pos Starting with Dem Vel = 0	Position Increment	Maximal Velocity	Acceleration	Deceleration	
VAI Increment Dem Pos	Position Increment	Maximal Velocity	Acceleration	Deceleration	
VAI Increment Target Pos	Position Increment	Maximal Velocity	Acceleration	Deceleration	
VAI Dec=Acc Increment Dem Pos	* Position Increment	Maximal Velocity	Acceleration		
VAI Dec=Acc Increment Target Pos	* Position Increment	Maximal Velocity	Acceleration		
VAI Predef Acc Increment Dem Pos	* Position Increment	Maximal Velocity			
VAI Predef Acc Increment Target Pos	* Position Increment	Maximal Velocity			
Predef VAI Increment Dem Pos	Position Increment				
Predef VAI Increment Target Pos	Position Increment				

Velocity Acceleration Interpolated Positioning Commands	Parameter 1	Parameter 2	Parameter 3	Parameter 4	Parameter 5
Stop VAI Stop	Deceleration				
Predef VAI Stop (QuickStop Deceleration)					
Trigger VAI Go To Pos On Falling Trigger Event	* Target Position	Maximal Velocity	Acceleration	Deceleration	
VAI Go To Pos On Rising Trigger Event	* Target Position	Maximal Velocity	Acceleration	Deceleration	
VAI Dec=Acc Go To Pos On Falling Trigger Event	* Target Position	Maximal Velocity	Acceleration		
VAI Dec=Acc Go To Pos On Rising Trigger Event	* Target Position	Maximal Velocity	Acceleration		
VAI Predef Acc Go To Pos On Falling Trigger Event	* Target Position	Maximal Velocity			
VAI Predef Acc Go To Pos On Rising Trigger Event	* Target Position	Maximal Velocity			

* not available for B1100

	Predef VAI Go To Abs Target Pos On Falling Trigger Event	* Target Position				
	Predef VAI Go To Abs Target Pos On Rising Trigger Event	* Target Position				
	VAI Increment Target Pos On Falling Trigger Event	* Position Increment	Maximal Velocity	Acceleration	Deceleration	
	VAI Increment Target Pos On Rising Trigger Event	* Position Increment	Maximal Velocity	Acceleration	Deceleration	
	VAI Dec=Acc Increment Target Pos On Falling Trigger Event	* Position Increment	Maximal Velocity	Acceleration		
	VAI Dec=Acc Increment Target Pos On Rising Trigger Event	* Position Increment	Maximal Velocity	Acceleration		
	VAI Predef Acc Increment Target Pos On Falling Trigger Event	* Position Increment	Maximal Velocity			
	VAI Predef Acc Increment Target Pos On Rising Trigger Event	* Position Increment	Maximal Velocity			
	Predef VAI Increment Target Pos On Falling Trigger Event	* Position Increment				
	Predef VAI Increment Target Pos On Rising Trigger Event	* Position Increment				
Event	VAI Change Motion Parameters On Negative Position Transition	* Trans. Event Pos.	Max Vel After Event	Accel. After Event	Decel. After Event	
	VAI Change Motion Parameters On Positive Position Transition	* Trans. Event Pos.	Max Vel After Event	Accel. After Event	Decel. After Event	
Capture	VAI Increment Captured Pos	* Position Increment	Maximal Velocity	Acceleration	Deceleration	
Analog	VAI Go To Analog Pos	* Maximal Velocity	Acceleration	Deceleration		
Velocity Acceleration Interpolated Positioning Commands (16 Bit)						
Absolute	VAI 16Bit Go To Pos	Target Position	Maximal Velocity	Acceleration	Deceleration	
	VAI 16Bit Go To Pos After Actual Command	* Target Position	Maximal Velocity	Acceleration	Deceleration	
	VAI 16Bit Go To Pos From Act Pos Starting With Dem Vel = 0	Target Position	Maximal Velocity	Acceleration	Deceleration	
	VAI 16Bit Go To Pos From Act Pos And Act Vel	Target Position	Maximal Velocity	Acceleration	Deceleration	
	Predef VAI 16Bit Go To Pos	Target Position				
	Predef VAI 16Bit Go To Pos After Actual Command	* Target Position				
	Predef VAI 16Bit Go To Pos From Act Pos Starting With Dem Vel = 0	Target Position				
	Predef VAI 16Bit Go To Pos From Act Pos And Act Vel	Target Position				
Increment	VAI 16Bit Increment Act Pos	Position Increment	Maximal Velocity	Acceleration	Deceleration	
	VAI 16Bit Increment Act Pos Starting with Dem Vel = 0	Position Increment	Maximal Velocity	Acceleration	Deceleration	
	VAI 16Bit Increment Dem Pos	Position Increment	Maximal Velocity	Acceleration	Deceleration	
	VAI 16Bit Increment Target Pos	Position Increment	Maximal Velocity	Acceleration	Deceleration	
	Predef VAI 16Bit Increment Dem Pos	Position Increment				
	Predef VAI 16Bit Increment Target Pos	Position Increment				
Stop	VAI 16Bit Stop	Deceleration				
	Predef VAI 16Bit Stop (QuickStop Deceleration)					
Trigger	VAI 16Bit Go To Pos On Falling Trigger Event	* Target Position	Maximal Velocity	Acceleration	Deceleration	
	VAI 16Bit Go To Pos On Rising Trigger Event	* Target Position	Maximal Velocity	Acceleration	Deceleration	
	Predef VAI 16Bit Go To Pos On Falling Trigger Event	* Target Position				
	Predef VAI 16Bit Go To Pos On Rising Trigger Event	* Target Position				
	VAI 16Bit Increment Target Pos On Falling Trigger Event	* Position Increment	Maximal Velocity	Acceleration	Deceleration	
	VAI 16Bit Increment Target Pos On Rising Trigger Event	* Position Increment	Maximal Velocity	Acceleration	Deceleration	
	Predef VAI 16Bit Increment Target Pos On Falling Trigger Event	* Position Increment				
	Predef VAI 16Bit Increment Target Pos On Rising Trigger Event	* Position Increment				
Event	VAI 16Bit Change Motion Parameters On Negative Position Transition	* Transition Event Position	Max Velocity After Event	Acceleration After Event	Deceleration After Event	
	VAI 16Bit Change Motion Parameters On Positive Position Transition	* Trans. Event Pos.	Max Vel After Event	Accel. After Event	Decel. After Event	
Time Curve Commands		Parameter 1	Parameter 2	Parameter 3	Parameter 4	Parameter 5
Curve	Time Curve With Default Parameters	* Curve ID				
	Time Curve With Default Parameters From Act Pos	* Curve ID				
	Time Curve With Adjustable Offset _c Time & Amplitude Scale	* Curve ID	Curve Offset	Curve Time	Amplitude Scale	
	Time Curve With Adjustable Offset _c Time Scale & Amplitude Scale	* Curve ID	Curve Offset	Time Scale	Amplitude Scale	
Time Curve Commands		Parameter 1	Parameter 2	Parameter 3	Parameter 4	Parameter 5
Curve to Position	Time Curve To Pos With Default Speed	* Curve ID	Target Position			
	Time Curve To Pos With Adjustable Time	* Curve ID	Target Position	Curve Time		
Trigger	Time Curve With Adjus. Offset _c Time & Ampl. Scale On Falling Trigger Event	* Curve ID	Curve Offset	Curve Time	Amplitude Scale	
	Time Curve With Adjus. Offset _c Time & Ampl. Scale On Rising Trigger Event	* Curve ID	Curve Offset	Curve Time	Amplitude Scale	
	Time Curve To Pos With Adjustable Time On Falling Trigger Event	* Curve ID	Target Position	Curve Time		
	Time Curve To Pos With Adjustable Time On Rising Trigger Event	* Curve ID	Target Position	Curve Time		
	Time Curve To Pos With Default Speed On Falling Trigger Event	* Curve ID	Target Position			
	Time Curve To Pos With Default Speed On Rising Trigger Event	* Curve ID	Target Position			
Encoder CAM Commands		Parameter 1	Parameter 2	Parameter 3	Parameter 4	Parameter 5
Control	Encoder Cam Disable (101xh)	*				
	Encoder Cam Enable (100xh)	*				
	Encoder Cam 1 Disable	*				
	Encoder Cam 1 Enable	*				
	Encoder Cam 2 Disable	*				
	Encoder Cam 2 Enable	*				
	Encoder CAM Go To Sync Pos	*				
	Encoder CAM Set Value	* Counter Value				
CAM1	Encoder Cam 1 Define Curve To Pos	* Curve ID	Curve Start Count	Target Position		
	Encoder Cam 1 Define Curve To Pos In Counts	* Curve ID	Curve Start Count	Target Position	Curve Length	
	Encoder Cam 1 Define Curve From Act Pos	* Curve ID	Curve Start Count			
	Encoder Cam 1 Define Curve With Default Parameters	* Curve ID	Curve Start Count			
	Encoder Cam 1 Define Curve With Amp Scale In Counts	* Curve ID	Curve Start Count	Amplitude Scale	Curve Length	
	Encoder Cam 1 Change Amp Scale and Length	* Amplitude Scale	Curve Length			
CAM2	Encoder Cam 2 Define Curve To Pos	* Curve ID	Curve Start Count	Target Position		
	Encoder Cam 2 Define Curve To Pos In Counts	* Curve ID	Curve Start Count	Target Position	Curve Length	
	Encoder Cam 2 Define Curve From Act Pos	* Curve ID	Curve Start Count			
	Encoder Cam 2 Define Curve With Default Parameters	* Curve ID	Curve Start Count			
	Encoder Cam 2 Define Curve With Amp Scale In Counts	* Curve ID	Curve Start Count	Amplitude Scale	Curve Length	
	Encoder Cam 2 Change Amp Scale and Length	* Amplitude Scale	Curve Length			

* not available for B1100

Trigger	Start Encoder Cam On Fall Trigger Event With Delay Counts	* Curve ID	Curve Start Delay			
	Start Encoder Cam On Rise Trigger Event With Delay Counts	* Curve ID	Curve Start Delay			
Position Indexing		Parameter 1	Parameter 2	Parameter 3	Parameter 4	Parameter 5
	Start Prefe VAI Encoder Position Indexing	* Target Position				
	Start VAI Encoder Position Indexing	* Target Position	Maximal Velocity	Acceleration	Deceleration	
	Stop Position Indexing And Predefined VAI Go To Pos	* Target Position				
	Stop Position Indexing And VAI Go To Pos	* Target Position	Maximal Velocity	Acceleration	Deceleration	
Position Streaming Commands		Parameter 1	Parameter 2	Parameter 3	Parameter 4	Parameter 5
	P Stream With Slave Generated Time Stamp	* Position				
	P Stream With Slave Generated Time Stamp and Configured Period Time	* Position				
	PV Stream With Slave Generated Time Stamp	* Position	Velocity			
	Stop Stream	*				
Force Control Commands		Parameter 1	Parameter 2	Parameter 3	Parameter 4	Parameter 5
	Force Ctrl Change Target Force	* Target Force				
	VAI Go To Pos With Force Ctrl Limit	* Target Position	Maximal Velocity	Acceleration	Force Limit	
	VAI Go To Pos With Force Ctrl Limit and Target Force	* Target Position	Maximal Velocity	Acceleration	Force Limit	Target Force
	VAI Go To Pos From Act Pos And Reset Force Control	* Target Position	Maximal Velocity	Acceleration	Deceleration	
Winding Application		Parameter 1	Parameter 2	Parameter 3	Parameter 4	Parameter 5
	Encoder Winding Start With Default Parameters	*				
	Encoder Winding Start With Default Parameters At Revolutions	* Start Rev. Count				
	Encoder Winding Restart Adaptation Of Left/Right Position and Disturbance	*				
	Encoder Winding Stop Adaptation Of Left/Right Position and Disturbance	*				
	Encoder Curve Winding Start With Default Parameters	* Curve ID				
	Encoder Curve Winding Start With Default Parameters At Revolutions	* Curve ID	Start Rev. Count			
Command Table Commands		Parameter 1	Parameter 2	Parameter 3	Parameter 4	Parameter 5
	Start Command Table Command	* Cmd Table Entry ID				
	Start Command Table Command On Falling Trigger Event	* Cmd Table Entry ID				
	Start Command Table Command On Rising Trigger Event	* Cmd Table Entry ID				
	IF Actual Position Greater Than	* Condition Value	Cmd. ID if True	Cmd. ID if False		
	IF Actual Position Less Than	* Condition Value	Cmd. ID if True	Cmd. ID if False		
	IF Analog Val On X4.4 Less Than	* Condition Value	Cmd. ID if True	Cmd. ID if False		
	IF Cmd Table Var 1 Greater Than	* Condition Value	Cmd. ID if True	Cmd. ID if False		
	IF Cmd Table Var 1 Less Than	* Condition Value	Cmd. ID if True	Cmd. ID if False		
	IF Cmd Table Var 2 Greater Than	* Condition Value	Cmd. ID if True	Cmd. ID if False		
	IF Cmd Table Var 2 Less Than	* Condition Value	Cmd. ID if True	Cmd. ID if False		
	IF Current Greater Than	* Condition Value	Cmd. ID if True	Cmd. ID if False		
	IF Current Less Than	* Condition Value	Cmd. ID if True	Cmd. ID if False		
	IF Demand Position Greater Than	* Condition Value	Cmd. ID if True	Cmd. ID if False		
	IF Demand Position Less Than	* Condition Value	Cmd. ID if True	Cmd. ID if False		
	IF Difference Position Greater Than	* Condition Value	Cmd. ID if True	Cmd. ID if False		
	IF Difference Position Less Than	* Condition Value	Cmd. ID if True	Cmd. ID if False		
	Wait Time	* Time				
	Wait Time Defined With Cmd Table Var 1	*				
	Wait Time Defined With Cmd Table Var 2	*				
	Wait until Actual Position Greater Than	* Act Pos Trig Level				
	Wait until Actual Position Less Than	* Act Pos Trig Level				
	Wait until Actual Velocity Greater Than	* Act Vel Trig Level				
	Wait until Actual Velocity Less Than	* Act Vel Trig Level				
	Wait until Current Greater Than	* Dem Curr Trig Lvl				
	Wait until Current Less Than	* Dem Curr Trig Lvl				
	Wait until Demand Position Greater Than	* Dem Pos Trig Level				
	Wait until Demand Position Less Than	* Dem Pos Trig Level				
	Wait until Demand Velocity Greater Than	* Dem Vel Trig Level				
	Wait until Demand Velocity Less Than	* Dem Vel Trig Level				
	Wait until Difference Position Greater Than	* Act Pos Trig Level				
	Wait until Difference Position Less Than	* Act Pos Trig Level				
	Wait until Difference Position unsigned Greater Than	* Act Pos Trig Level				
	Wait until Difference Position unsigned Less Than	* Act Pos Trig Level				
	Wait until Falling Trigger Edge	*				
	Wait until In Target Position	*				
	Wait until Motion Finished	*				
	Wait until Rising Trigger Edge	*				
	Set Cmd Table Var 1 To	* Set Value Of Var 1				
	Set Cmd Table Var 2 To	* Set Value Of Var 2				
	Add To Cmd Table Var 1	* Add Value Of Var 1				
	Add To Cmd Table Var 2	* Add Value Of Var 2				
	VAI Go To Cmd Tab Var1 Pos	* Maximal Velocity	Acceleration	Deceleration		
	VAI Go To Cmd Tab Var2 Pos	* Maximal Velocity	Acceleration	Deceleration		
	Write Cmd Table Var 1 To UPID RAM value	* UPID				
	Write Cmd Table Var 2 To UPID RAM value	* UPID				
	Modify Command Table 16 bit Parameter in RAM	* Cmd Table Entry ID	Parameter Offset	Parameter Value		
	Modify Command Table 32 bit Parameter in RAM	* Cmd Table Entry ID	Parameter Offset	Parameter Value		

* not available for B1100



A list with the latest motion commands is available on: www.LinMot.com

Force Control

The new "Force Control" technology function for Series E1100 servo drives allows closed-loop force control at a resolution of up to 0.1N.

Force control allows precise definition of a constant force across the entire stroke, regardless of the current position.

Since the force generated by the linear motor is measured by the load cell, and is controlled directly in the Servo Drive, interference effects, such as differences in friction, dirt, slip-stick effects, temperature variations, and other variables are compensated for.

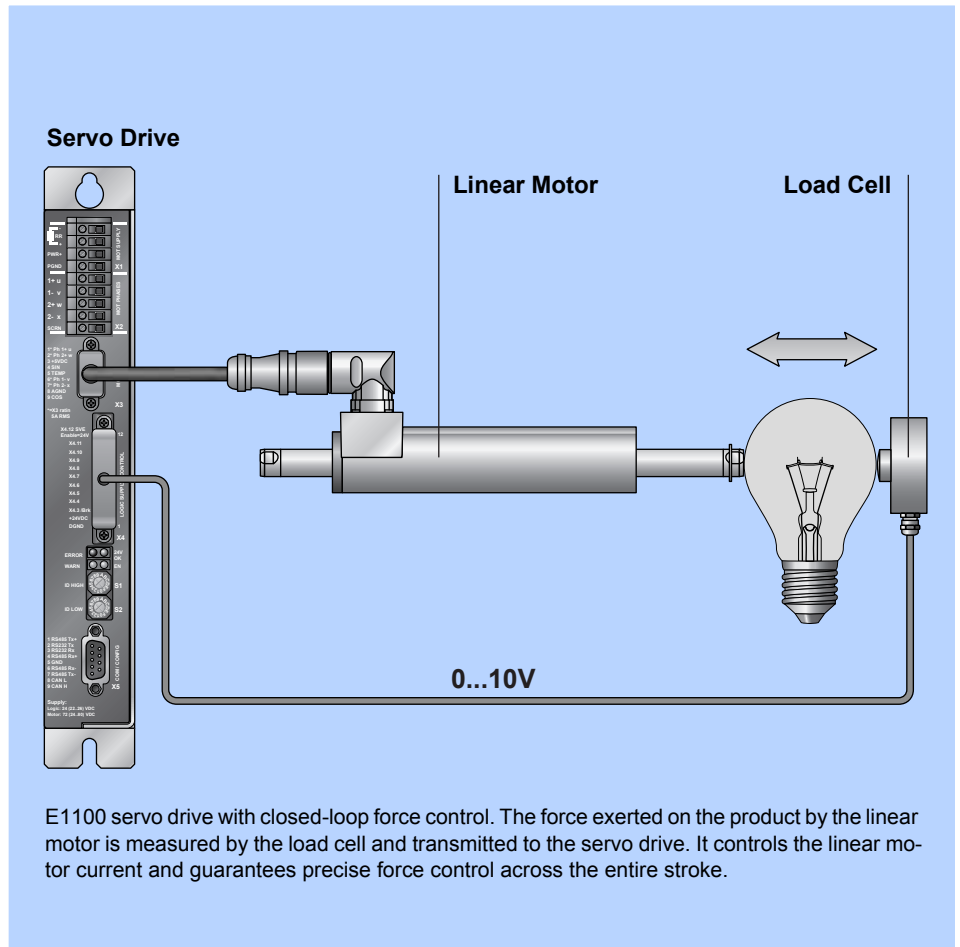

E1100 servo drive with closed-loop force control. The force exerted on the product by the linear motor is measured by the load cell and transmitted to the servo drive. It controls the linear motor current and guarantees precise force control across the entire stroke.

Force Control commands

VAI Go To Pos With Force Ctrl Limit
Moves to the defined target position. As soon as the measured force reaches the force limit, the drive changes to force control mode, with the target force = force limit. To move with position control again, use the command, VAI Go To Pos From Act Pos And Reset Force Control.

Force Ctrl Change Target Force
Using this command, the target force can be changed in force control mode.

VAI Go To Pos With Force Ctrl Limit And Target Force
Travels to a defined target position. As soon as the measured force reaches the force limit, the drive changes to force control mode, with the target force = target force. To move with position control again, use the command, VAI Go To Pos From Act Pos And Reset Force Control.

VAI Go To Pos From Act Pos And Reset Force Control
Reactivates position control, and travels to the defined position.

Activation of force control

Activation of force control requires an activation code:

Ordering Information:
TF-1100-Force-Control
Technology Function Force Control
Item Number: 0150-2503

Detailed descriptions of the commands are found in the Motion Control SW manual.

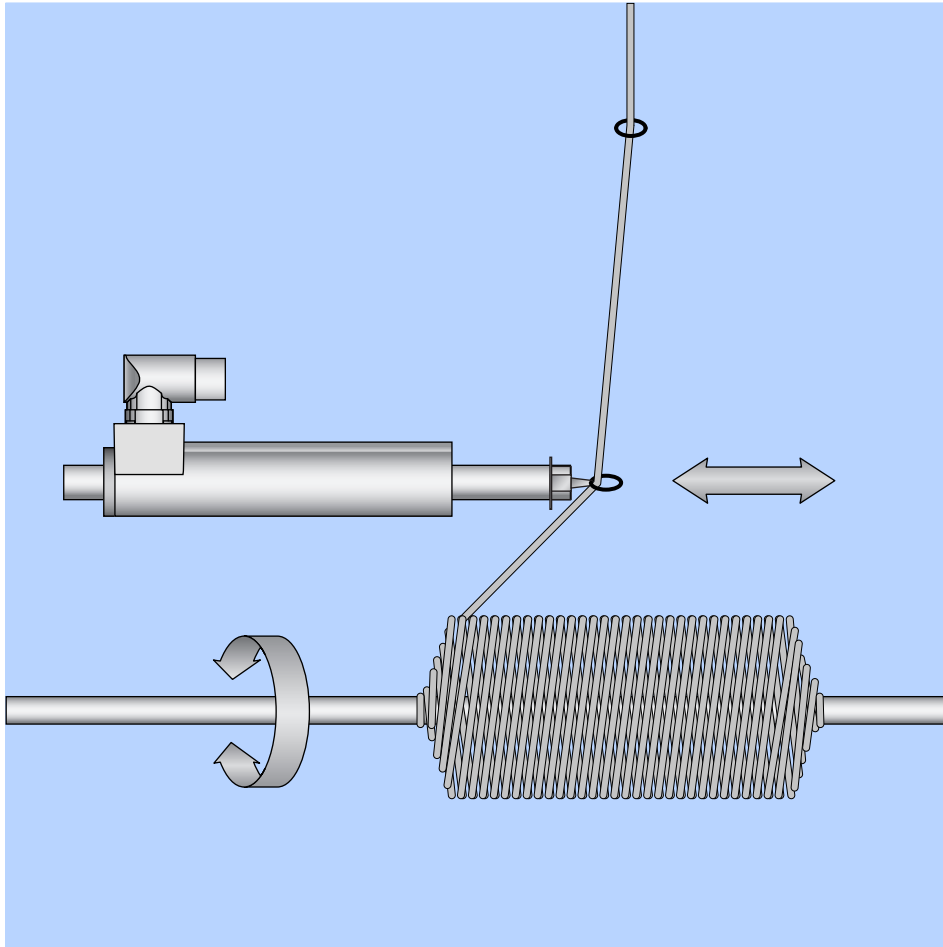

Winding

For winding cotton or synthetic yarns, threads, optical data cables, etc., the "winding" functional component is available with Series E1100 Servo Drives. This carries out a complete winding process on its own, without any overarching drive.

The complete winding process is specified by a few parameters. To avoid the so-called "dog bone" effect, two different pre-programmed correction modes can be selected.

Winding Parameter

A complete winding process is specified by the following parameters:

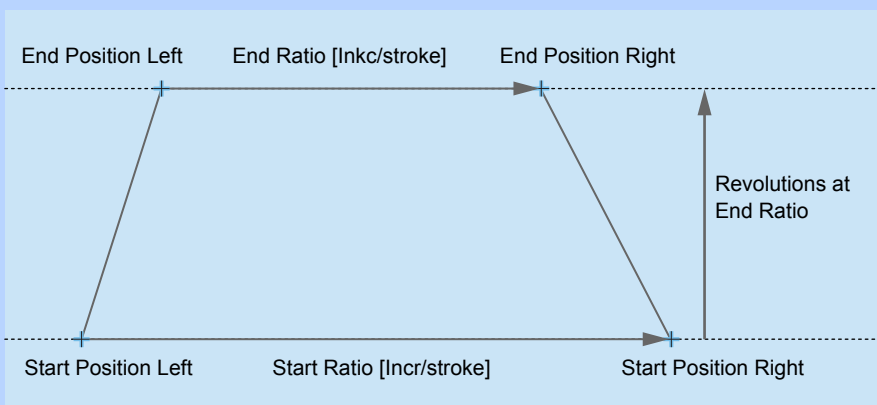

Parallel and Antiparallel Disturbance

Parallel Disturbance

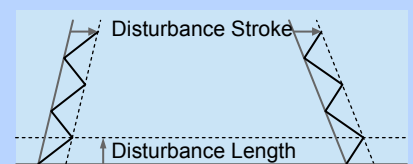

Antiparallel Disturbance

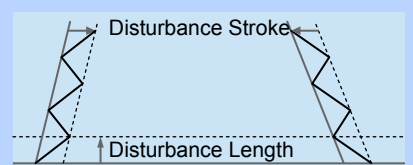

3-phase Motor with single ended Hall sensors and Position Encoder ABZ (differential RS422)

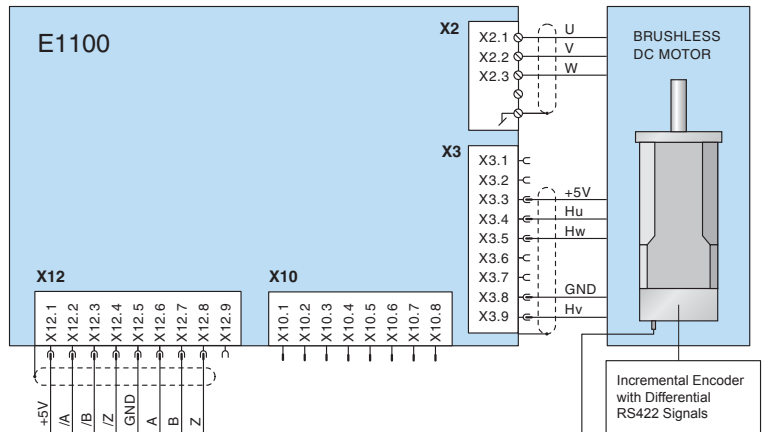

3-phase Motor and Position Encoder ABZ with commutating signals (differential RS422)

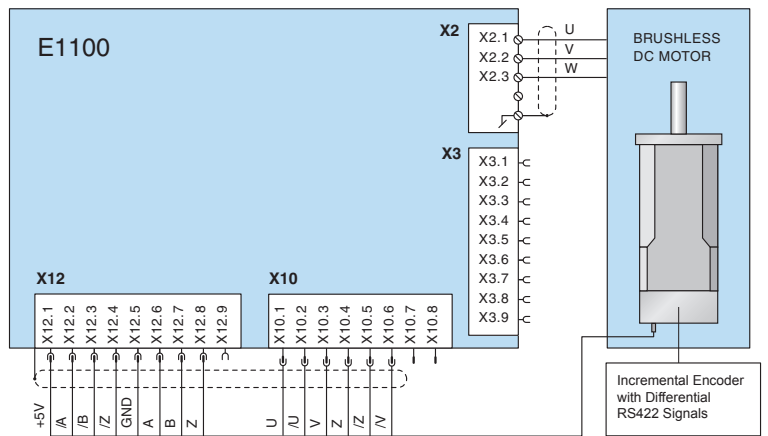

3-phase Motor with analog Hall Sensors (0-5VDC)

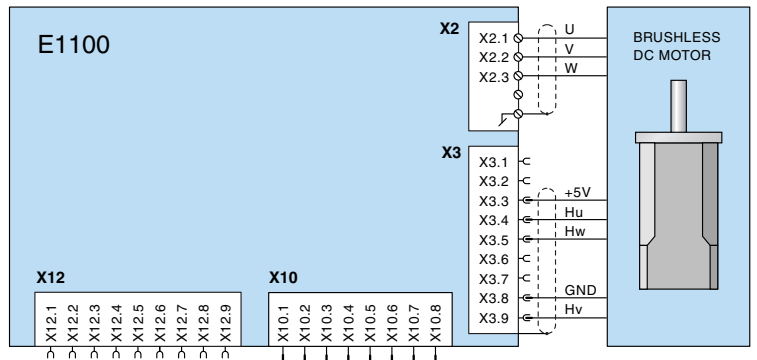

3-phase Motor and Position Encoder ABZ (differential RS422) without commutating signals

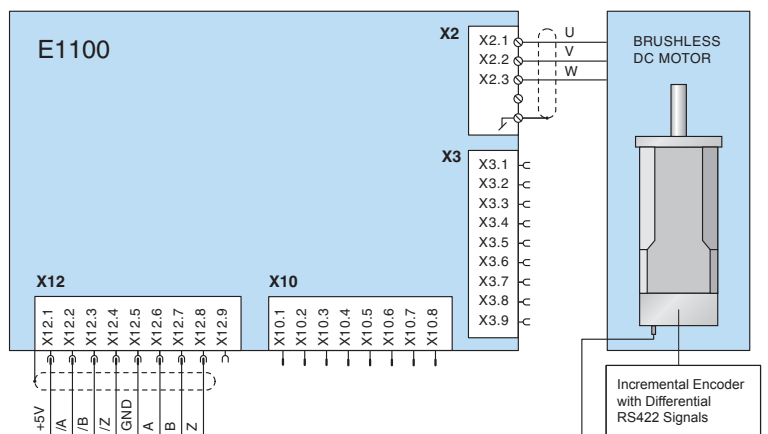

3-phase Motor with single ended Hall sensors and Position Encoder ABZ (differential RS422)

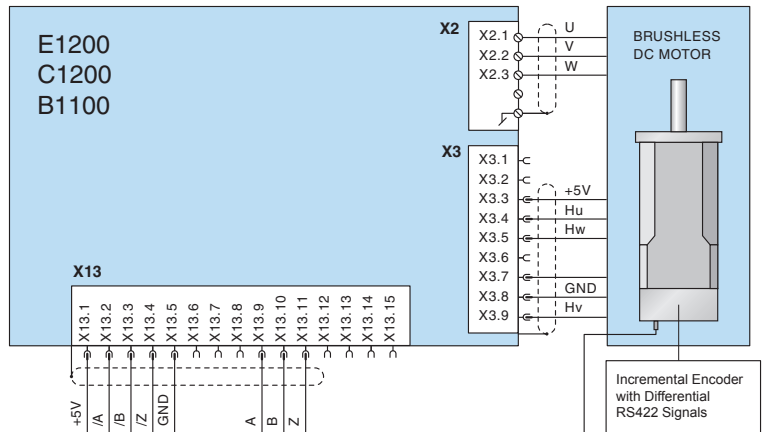

3-phase Motor and Position Encoder ABZ with commutating signals (differential RS422)

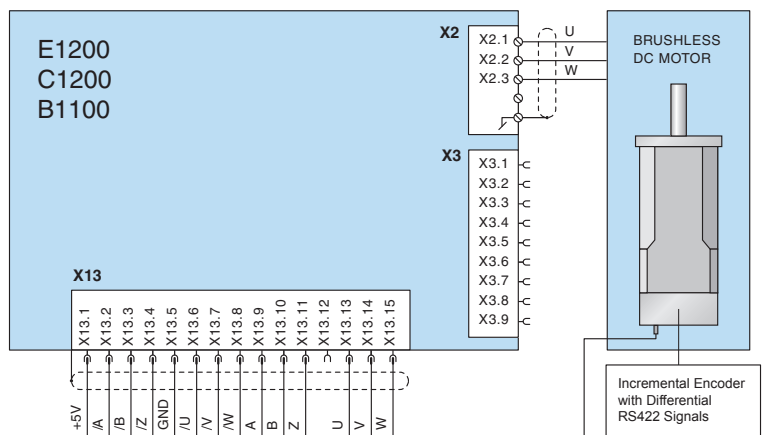

3-phase Motor with analog Hall Sensors (0-5VDC)

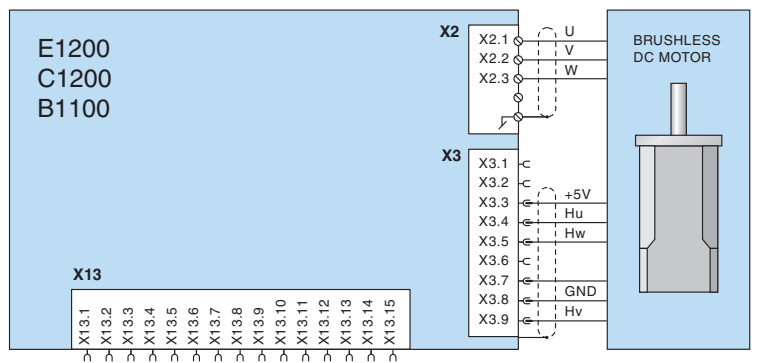

3-phase Motor and Position Encoder ABZ (differential RS422) without commutating signals

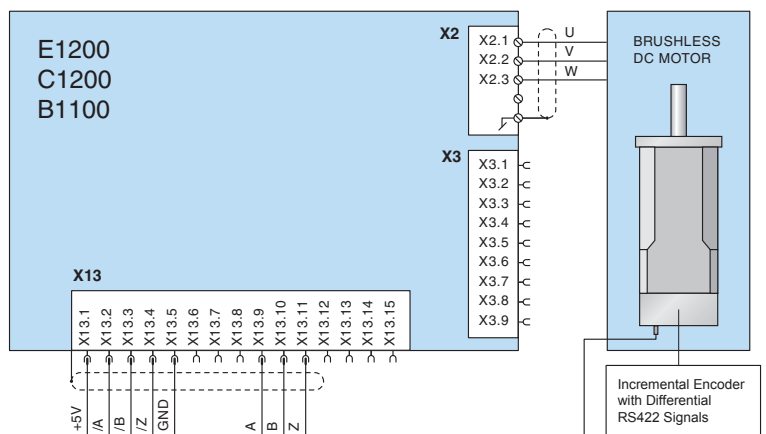



LinMot®

Declaration of Conformity

CE-Marking



Manufacturer:

NTI AG *LinMot*
Haerdlistrasse 15
CH-8957 Spreitenbach
Switzerland

Tel.: +41(0) 56 419 91 91
Fax: +41(0) 56 419 91 92

Products:

LinMot® Servo Drive Series E1100

Type	Part Number	Type	Part Number	Type	Part Number
E1100-MP	0150-1661	E1100-MP-HC	0150-1662		
E1100-MT	0150-1663	E1100-MT-HC	0150-1664		
E1100-RS	0150-1677	E1100-RS-HC	0150-1678	E1100-RS-XC	0150-1862
E1100-CO	0150-1681	E1100-CO-HC	0150-1682	E1100-CO-XC	0150-1683
E1100-DN	0150-1679	E1100-DN-HC	0150-1680	E1100-DN-XC	0150-1863
E1130-DP	0150-1667	E1130-DP-HC	0150-1668	E1130-DP-XC	0150-1861
E1100-GP	0150-1665	E1100-GP-HC	0150-1666	E1100-GP-XC	0150-1864

The product must be mounted and used in strict accordance with the installation instruction contained within the User's Manual, a copy of which may be obtained from NTI Ltd.

I declare that as the authorized representative, the above information in relation to the supply/manufacture of this product is in conformity with the stated standards and other related documents in compliance with the protection requirements of the Electromagnetic Compatibility (EMC) Directive 2004/108/EC.

EN 61000-6-2	EN 61000-4-2	Class A	Immunity for industrial environment	
	EN 61000-4-3	Class A		Electrostatic discharge immunity (ESD)
	EN 61000-4-4	Class A		Radiated electromagnetic field immunity
	EN 61000-4-5	Class A		Fast transients / burst immunity (EFT)
	EN 61000-4-6	Class A		Slow transients immunity (Surges)
EN 61000-6-4	EN 55022	Class A	Emission for industrial environment	
			Radiated Emission	

Company Name:

LinMot
NTI AG

Place, Date:

Spreitenbach, November 15th, 2007

Signature:

R. Rohner / CEO NTI AG



LinMot®

Declaration of Conformity

CE-Marking



Manufacturer:

NTI AG *LinMot*
Haerdlistrasse 15
CH-8957 Spreitenbach
Switzerland

Tel.: +41(0) 56 419 91 91
Fax: +41(0) 56 419 91 92

Products:

LinMot® Servo Drives Series E1200 / C1200 / E1400

Type	Part Number	Type	Part Number	Type	Part Number
E1200-GP-UC	0150-1771	C1200-GP-UC	0150-	E1400-GP-QN	0150-1779
E1230-DP-UC	0150-1766	C1230-DP-UC	0150-	E1400-DP-QN	0150-1786
E1250-EC-UC	0150-1763	C1250-EC-UC	0150-	E1400-EC-QN	0150-1784
E1250-PL-UC	0150-1760	C1250-PL-UC	0150-	E1400-IP-QN	0150-1782
E1250-IP-UC	0150-1761	C1250-IP-UC	0150-	E1400-PL-QN	0150-1791
E1250-PN-UC	0150-1762	C1250-PN-UC	0150-	E1400-PN-QN	0150-1783
E1250-SC-UC	0150-1764	C1250-SC-UC	0150-	E1400-SC-QN	0150-1785

The product must be mounted and used in strict accordance with the installation instruction contained within the User's Manual, a copy of which may be obtained from NTI Ltd.

I declare that as the authorized representative, the above information in relation to the supply/manufacture of this product is in conformity with the stated standards and other related documents in compliance with the protection requirements of the Electromagnetic Compatibility (EMC) Directive 2004/108/EC.

EN 61000-6-2			Immunity for industrial environment
	EN 61000-4-2	Class A	Electrostatic discharge immunity (ESD)
	EN 61000-4-3	Class A	Radiated electromagnetic field immunity
	EN 61000-4-4	Class A	Fast transients / burst immunity (EFT)
	EN 61000-4-5	Class A	Slow transients immunity (Surges)
	EN 61000-4-6	Class A	Conducted radio frequency immunity
EN 61000-6-4			Emission for industrial environment
	EN 55022	Class A	Radiated Emission

Company Name:

LinMot
NTI AG

Place, Date:

Spreitenbach, November 15th, 2007

Signature:

R. Rohner / CEO NTI AG



LinMot®

Declaration of Conformity

CE-Marking



Manufacturer:

NTI AG *LinMot*
Haerdlistrasse 15
CH-8957 Spreitenbach
Switzerland

Tel.: +41(0) 56 419 91 91
Fax: +41(0) 56 419 91 92

Products:

LinMot® Servo Drive Series B1100

Type	Part Number	Type	Part Number	Type	Part Number
B1100-PP	0150-1735	B1100-PP-HC	0150-1736	B1100-PP-XC	0150-1740
B1100-VF	0150-1685	B1100-VF-HC	0150-1686	B1100-VF-XC	0150-1739
B1100-GP	0150-1737	B1100-GP-HC	0150-1738	B1100-GP-XC	0150-1741
B1150-ML	0150-1796	B1150-ML-HC	0150-1797	B1150-ML-XC	0150-1798
B8050-ML-EL	0150-1878	B8050-ML-PN	0150-1880		
B8050-ML-IP	0150-1879	B8050-ML-SC	0150-1881		
B8050-ML-PL	0150-1877				

The product must be mounted and used in strict accordance with the installation instruction contained within the User's Manual, a copy of which may be obtained from NTI Ltd.

I declare that as the authorized representative, the above information in relation to the supply/manufacture of this product is in conformity with the stated standards and other related documents in compliance with the protection requirements of the Electromagnetic Compatibility (EMC) Directive 2004/108/EC.

EN 61000-6-2	EN 61000-4-2	Class A	Immunity for industrial environment	
	EN 61000-4-3	Class A		Electrostatic discharge immunity (ESD)
	EN 61000-4-4	Class A		Radiated electromagnetic field immunity
	EN 61000-4-5	Class A		Fast transients / burst immunity (EFT)
	EN 61000-4-6	Class A		Slow transients immunity (Surges)
EN 61000-6-4	EN 55022	Class A	Emission for industrial environment	
			Radiated Emission	

Company Name:

LinMot
NTI AG

Place, Date:

Spreitenbach, November 15th, 2007

Signature:

R. Rohner / CEO NTI AG



LinMot®

Declaration of Conformity

CE-Marking



Manufacturer:

NTI AG *LinMot*
Haerdlistrasse 15
CH-8957 Spreitenbach
Switzerland

Tel.: +41(0) 56 419 91 91
Fax: +41(0) 56 419 91 92

Products:

LinMot® Servo Drives Series E100/E1001

Type	Part Number	Type	Part Number	Type	Part Number	Type	Part Number
E100-AT	0150-1601	E1001-DN	0150-1645	E130-DP	0150-1621	E1001-CO	0150-1673
E200-AT	0150-1602	E2001-DN	0150-1646	E230-DP	0150-1622	E2001-CO	0150-1674
E400-AT	0150-1604	E4001-DN	0150-1648	E430-DP	0150-1624	E4001-CO	0150-1676
E1001-AT	0150-1605	E100-MT	0150-1611	E1031-DP	0150-1625	E110-VF	0150-1651
E2001-AT	0150-1606	E200-MT	0150-1612	E2031-DP	0150-1626	E210-VF	0150-1652
E4001-AT	0150-1608	E400-MT	0150-1614	E4031-DP	0150-1628	E1010-VF	0150-1655
E100-DN	0150-1641	E1001-MT	0150-1615	E100-CO	0150-1669	E2010-VF	0150-1656
E200-DN	0150-1642	E2001-MT	0150-1616	E200-CO	0150-1670		
E400-DN	0150-1644	E4001-MT	0150-1618	E400-CO	0150-1672		

The product must be mounted and used in strict accordance with the installation instruction contained within the User's Manual, a copy of which may be obtained from NTI Ltd.

I declare that as the authorized representative, the above information in relation to the supply/manufacture of this product is in conformity with the stated standards and other related documents in compliance with the protection requirements of the Electromagnetic Compatibility (EMC) Directive 2004/108/EC.

EN 61000-6-4	EN 55011	Class A
EN 61000-6-2	EN 61000-4-2	4 kV contact- / 8kV air discharge
	EN 61000-4-4	1 kV signal- / 2kV power connections
	EN 61000-4-3	10 V/m
	EN 61000-4-6	10 V
	EN 50204	10 V/m

Company Name:

LinMot
NTI AG

Place, Date:

Spreitenbach, November 15th, 2007

Signature:

R. Rohner / CEO NTI AG



LinMot®

Declaration of Conformity

CE-Marking



Manufacturer:

NTI AG *LinMot*
Haerdlistrasse 15
CH-8957 Spreitenbach
Switzerland

Tel.: +41(0) 56 419 91 91
Fax: +41(0) 56 419 91 92

Products:

LinMot® Linear Servo Motors Series PS01

Type	Part Number	Type	Part Number	Type	Part Number
PS01-23x80-R	0150-1233	PS01-23x80-R20	0150-1241	PS02-23Sx80-F	0150-1272
PS01-23x160-R	0150-1234	PS01-23x160-R20	0150-1242	PS02-23Sx80F-HP-K	0150-1285
PS01-23x160F-R	0150-1235	PS01-23x160F-R20	0150-1243	PS01-23x80	0150-1201
PS01-37x120-C	0150-1223	PS01-37x120-C20	0150-1237	PS01-23x160	0150-1202
PS01-37x240-C	0150-1224	PS01-37x240-C20	0150-1238	PS01-37x120	0150-1204
PS01-37x240F-C	0150-1225	PS01-37x240F-C20	0150-1239	PS01-37x240	0150-1203
PS01-48x240-C	0150-1219			PS01-37x240F	0150-1256
PS01-48x240F-C	0150-1220	PS01-23x80F-HP-R20	0150-1260		
PS01-48x360F-C	0150-1269	PS01-23x160H-HP-R20	0150-1255	PS01-37x120F-HP-SSC-R	0150-1282
		PS01-37x120F-HP-C20	0150-1252	PS01-37x120F-HP-SSC-R-FC	0150-1283
PS01-23x80F-HP-R	0150-1259			PS01-48x240F-SSC-C	0150-1267
PS01-23x160H-HP-R	0150-1254			PS01-48x240F-SSC-C-FC	0150-1268
PS01-37x120F-HP-C	0150-1251			PS01-48x360F-SSC-C	0150-1270
				PS01-48x360F-SSC-C-FC	0150-1271

The product must be mounted and used in strict accordance with the installation instruction contained within the User's Manual, a copy of which may be obtained from NTI Ltd.

I declare that as the authorized representative, the above information in relation to the supply/manufacture of this product is in conformity with the stated standards and other related documents in compliance with the protection requirements of the Electromagnetic Compatibility (EMC) Directive 2004/108/EC.

EN 61000-6-2		Immunity for industrial environment
	EN 61000-4-2 Class A	Electrostatic discharge immunity (ESD)
	EN 61000-4-3 Class A	Radiated electromagnetic field immunity
	EN 61000-4-4 Class A	Fast transients / burst immunity (EFT)
	EN 61000-4-5 Class A	Slow transients immunity (Surges)
	EN 61000-4-6 Class A	Conducted radio frequency immunity
EN 61000-6-4		Emission for industrial environment
	EN 55022 Class A	Radiated Emission

Company Name:

LinMot
NTI AG

Place, Date:

Spreitenbach, November 15th, 2007

R. Rohner / CEO NTI AG



LinMot®

Declaration of Conformity

CE-Marking



Manufacturer:

NTI AG *LinMot*
Haerdlistrasse 15
CH-8957 Spreitenbach
Switzerland

Tel.: +41(0) 56 419 91 91
Fax: +41(0) 56 419 91 92

Products:

LinMot® Switched Mode Power Supplies Series S01

Type	Part Number	Type	Part Number	Type	Part Number
S01-24/150	0150-1944	S01-48/150	0150-1940	S01-72/300	0150-1942
S01-24/300	0150-1945	S01-48/300	0150-1941	S01-72/600	0150-1943
		S01-48/600	0150-1946	S01-72/500	0150-1874
				S01-72/1000	0150-1872

The product must be mounted and used in strict accordance with the installation instruction contained within the User's Manual, a copy of which may be obtained from NTI Ltd.

I declare that as the authorized representative, the above information in relation to the supply/manufacture of this product is in conformity with the stated standards and other related documents in compliance with the protection requirements of the Electromagnetic Compatibility (EMC) Directive 2004/108/EC.

Safety standard	EN 60950	1992/A1/1993+A2/1993
EMC	EN 50082	1995
Emission (EMI)	EN 55011	Class B
	LVD 73/23/EEC	

Company Name:

LinMot
NTI AG

Place, Date:

Zürich, February 24th, 2003

Signature:

R. Rohner / CEO NTI AG



Declaration of Conformity
CE-Marking



Manufacturer:

NTI AG *LinMot*
Haerdlistrasse 15
CH-8957 Spreitenbach
Switzerland

Tel.: +41(0) 56 419 91 91
Fax: +41(0) 56 419 91 92

Products:

LinMot® Transformer Supplies T01

Type	Part Number	Type	Part Number	Type	Part Number
T01-72/420-Multi	0150-1869	T01-72/900-Multi	0150-1870	T01-72/1500-Multi	0150-1871
T01-72/420-1ph	0150-1859				

The product must be mounted and used in strict accordance with the installation instruction contained within the User's Manual, a copy of which may be obtained from NTI Ltd.

I declare that as the authorized representative, the above information in relation to the supply/manufacture of this product is in conformity with the stated standards and other related documents in compliance with the protection requirements of the Electromagnetic Compatibility (EMC) Directive 2004/108/EC.

VDE0570	EN 61558-2-6	Part 2-6
VDE0570	EN 61000-6-2 EN 61000-6-4	

Company Name:

LinMot
NTI AG

Place, Date:

Zürich, February 24th, 2003

Signature:

R. Rohner / CEO NTI AG

Item	Description	Part Number
LINEAR MOTOR STATORS: CONNECTOR TYPES		
STANDARD		
PS01-23x80-R	stator with IP67 connector M17/9(m)	0150-1233
PS01-23x160-R	stator with IP67 connector M17/9(m)	0150-1234
PS01-23x160F-R	stator with IP67 connector M17/9(m)	0150-1235
PS01-37x120-C	stator with IP67 connector M23/9(m)	0150-1223
PS01-37x240-C	stator with IP67 connector M23/9(m)	0150-1224
PS01-37x240F-C	stator with IP67 connector M23/9(m)	0150-1225
PS01-48x240-C	stator with IP67 connector M23/9(m)	0150-1219
PS01-48x240F-C	stator with IP67 connector M23/9(m)	0150-1220
PS01-48x360F-C	stator with IP67 connector M23/9(m)	0150-1269
HIGH PERFORMANCE		
PS01-23x80F-HP-R	stator HP with IP67 connector M17/9(m)	0150-1259
PS01-23x160H-HP-R	stator HP with IP67 connector M17/9(m)	0150-1254
PS01-37x120F-HP-C	stator HP with IP67 connector M23/9(m)	0150-1251
LINEAR MOTOR STATORS: CABLE TYPES		
STANDARD		
PS01-23x80-R20	stator, 0.2m cable, IP67 con. M17/9(m)	0150-1241
PS01-23x160-R20	stator, 0.2m cable, IP67 con. M17/9(m)	0150-1242
PS01-23x160F-R20	stator, 0.2m cable, IP67 con. M17/9(m)	0150-1243
PS01-37x120-C20	stator, 0.2m cable, IP67 con. M23/9(m)	0150-1237
PS01-37x240-C20	stator, 0.2m cable, IP67 con. M23/9(m)	0150-1238
PS01-37x240F-C20	stator, 0.2m cable, IP67 con. M23/9(m)	0150-1239
HIGH PERFORMANCE		
PS01-23x80F-HP-R20	stator HP, 0.2m cable, IP67, M17/9(m)	0150-1260
PS01-23x160H-HP-R20	stator HP, 0.2m cable, IP67, M17/9(m)	0150-1255
PS01-37x120F-HP-C20	stator HP, 0.2m cable, IP67, M23/9(m)	0150-1252
STATORS WITH F-, K-, D- AND P- CONNECTORS		
PS02-23Sx80-F	stator w. flat cable connector 13pin	0150-1272
PS02-23Sx80F-HP-K	stator HP with K-connector IP50	0150-1285
PS01-23x80	stator, cable 1m, connector D-Sub-9(m)	0150-1201
PS01-23x160	stator, cable 1m, connector D-Sub-9(m)	0150-1202
PS01-37x120	stator, cable 1.5m, connector P/10(m)	0150-1204
PS01-37x240	stator, cable 1.5m, connector P/10(m)	0150-1203
PS01-37x240F	stator, cable 1.5m, connector P/10(m)	0150-1256
STATORS IN STAINLESS STEEL - IP69K		
PS01-37x120F-HP-SSC-R	stator stainless steel IP69K	0150-1282
PS01-37x120F-HP-SSC-R-FC	stator stainless steel IP69K, FC	0150-1283
PS01-48x240F-SSC-C	stator stainless steel IP69K	0150-1267
PS01-48x240F-SSC-C-FC	stator stainless steel IP69K, FC	0150-1268
PS01-48x360F-SSC-C	stator stainless steel IP69K	0150-1270
PS01-48x360F-SSC-C-FC	stator stainless steel IP69K, FC	0150-1271
SLIDERS STANDARD		
PL01-12x130/80	slider "standard"	0150-1399
PL01-12x170/120	slider "standard"	0150-1301
PL01-12x190/140	slider "standard"	0150-1302
PL01-12x200/100	slider "standard"	0150-1305
PL01-12x230/130	slider "standard"	0150-1306
PL01-12x270/170	slider "standard"	0150-1307
PL01-12x290/240	slider "standard"	0150-1320
PL01-12x350/300	slider "standard"	0150-1322
PL01-12x420/370	slider "standard"	0150-1324
PL01-12x480/430	slider "standard"	0150-1372
PL01-12x580/530	slider "standard"	0150-1355
PL01-12x760/710	slider "standard"	0150-1366
PL01-12x850/800	slider "standard"	0150-1365
PL01-20x240/160	slider "standard"	0150-1346
PL01-20x300/220	slider "standard"	0150-1348
PL01-20x305/160	slider "standard"	0150-1311
PL01-20x365/220	slider "standard"	0150-1312
PL01-20x395/320	slider "standard"	0150-1318
PL01-20x500/420	slider "standard"	0150-1328
PL01-20x600/520	slider "standard"	0150-1330
PL01-20x700/620	slider "standard"	0150-1332
PL01-20x800/720	slider "standard"	0150-1334
PL01-20x900/820	slider "standard"	0150-1336
PL01-20x1000/920	slider "standard"	0150-1338
PL01-20x1200/1120	slider "standard"	0150-1340
PL01-20x1300/1220	slider "standard"	0150-1377
PL01-20x1400/1320	slider "standard"	0150-1342
PL01-20x1600/1520	slider "standard"	0150-1344
PL01-28x350/270	slider "standard"	0150-1380
PL01-28x410/330	slider "standard"	0150-1381
PL01-28x500/420	slider "standard"	0150-1382
PL01-28x620/540	slider "standard"	0150-1383
PL01-28x710/630	slider "standard"	0150-1384
PL01-28x800/720	slider "standard"	0150-1385
PL01-28x920/840	slider "standard"	0150-1386
PL01-28x1010/930	slider "standard"	0150-1387
PL01-28x1220/1140	slider "standard"	0150-1388
PL01-28x1400/1320	slider "standard"	0150-1389
PL01-28x1610/1530	slider "standard"	0150-1390
PL01-28x1820/1740	slider "standard"	0150-1395
PL01-28x2000/1920	slider "standard"	0150-1396

Item	Description	Part Number
HIGH PERFORMANCE SLIDERS		
PL01-12x130/90-HP	slider "High Performance"	0150-2209
PL01-12x150/110-HP	slider "High Performance"	0150-2281
PL01-12x170/130-HP	slider "High Performance"	0150-1529
PL01-12x200/160-HP	slider "High Performance"	0150-1518
PL01-12x230/190-HP	slider "High Performance"	0150-1519
PL01-12x270/230-HP	slider "High Performance"	0150-1520
PL01-12x290/250-HP	slider "High Performance"	0150-1521
PL01-12x350/310-HP	slider "High Performance"	0150-1522
PL01-12x420/380-HP	slider "High Performance"	0150-1523
PL01-12x480/440-HP	slider "High Performance"	0150-1524
PL01-12x580/540-HP	slider "High Performance"	0150-1525
PL01-12x760/720-HP	slider "High Performance"	0150-1526
PL01-12x850/810-HP	slider "High Performance"	0150-1527
PL01-20x240/180-HP	slider High Performance	0150-1505
PL01-20x300/240-HP	slider High Performance	0150-1506
PL01-20x360/300-HP	slider High Performance	0150-1507
PL01-20x400/340-HP	slider High Performance	0150-1508
PL01-20x500/440-HP	slider High Performance	0150-1509
PL01-20x600/540-HP	slider High Performance	0150-1510
PL01-20x700/640-HP	slider High Performance	0150-1511
PL01-20x800/740-HP	slider High Performance	0150-1512
PL01-20x900/840-HP	slider High Performance	0150-1513
PL01-20x1000/940-HP	slider High Performance	0150-1514
PL01-20x1200/1140-HP	slider High Performance	0150-1515
PL01-20x1400/1340-HP	slider High Performance	0150-1516
PL01-20x1600/1540-HP	slider High Performance	0150-1517
HIGH CLEARANCE SLIDERS		
PL01-19x240/160	slider "high clearance"	0150-1448
PL01-19x300/220	slider "high clearance"	0150-1449
PL01-19x305/160	slider "high clearance"	0150-1450
PL01-19x350/260	slider "high clearance"	0150-1498
PL01-19x395/320	slider "high clearance"	0150-1452
PL01-19x500/420	slider "high clearance"	0150-1455
PL01-19x600/520	slider "high clearance"	0150-1456
PL01-19x700/620	slider "high clearance"	0150-1457
PL01-19x800/720	slider "high clearance"	0150-1458
PL01-27x350/270	slider "high clearance"	0150-1467
PL01-27x410/330	slider "high clearance"	0150-1468
PL01-27x500/420	slider "high clearance"	0150-1469
PL01-27x620/540	slider "high clearance"	0150-1470
PL01-27x710/630	slider "high clearance"	0150-1471
PL01-27x800/720	slider "high clearance"	0150-1472
PL01-27x920/840	slider "high clearance"	0150-1447
PL01-27x1010/930	slider "high clearance"	0150-1473
PL01-27x1220/1140	slider "high clearance"	0150-1587
PL01-27x1400/1320	slider "high clearance"	0150-1588
PL01-27x1610/1530	slider "high clearance"	0150-1589
PL01-27x1820/1740	slider "high clearance"	0150-1590
PL01-27x2000/1920	slider "high clearance"	0150-1553
HEAVY DUTY SLIDERS		
PL02-12x130/80	slider "heavy duty"	0150-1424
PL02-12x170/120	slider "heavy duty"	0150-1303
PL02-12x190/140	slider "heavy duty"	0150-1304
PL02-12x200/100	slider "heavy duty"	0150-1308
PL02-12x230/130	slider "heavy duty"	0150-1309
PL02-12x270/170	slider "heavy duty"	0150-1310
PL02-12x290/240	slider "heavy duty"	0150-1321
PL02-12x350/300	slider "heavy duty"	0150-1323
PL02-12x420/370	slider "heavy duty"	0150-1325
PL02-12x480/430	slider "heavy duty"	0150-1373
PL02-12x580/530	slider "heavy duty"	0150-1356
PL02-20x240/160	slider "heavy duty"	0150-1347
PL02-20x300/220	slider "heavy duty"	0150-1349
PL02-20x305/160	slider "heavy duty"	0150-1314
PL02-20x365/220	slider "heavy duty"	0150-1315
PL02-20x395/320	slider "heavy duty"	0150-1319
PL02-20x500/420	slider "heavy duty"	0150-1329
PL02-20x600/520	slider "heavy duty"	0150-1331
PL02-20x700/620	slider "heavy duty"	0150-1333
PL02-20x800/720	slider "heavy duty"	0150-1335
PL02-20x900/820	slider "heavy duty"	0150-1337
PL02-28x350/270	slider 'heavy duty'	0150-1411
PL02-28x410/330	slider 'heavy duty'	0150-1412
PL02-28x500/420	slider 'heavy duty'	0150-1413
PL02-28x620/540	slider 'heavy duty'	0150-1414
PL02-28x710/630	slider 'heavy duty'	0150-1415
PL02-28x800/720	slider 'heavy duty'	0150-1416
PL02-28x920/840	slider 'heavy duty'	0150-1417
HOLLOW SLIDERS STANDARD		
PL01-12x130/80-L	slider "standard-L"	0150-1445
PL01-12x170/120-L	slider "standard-L"	0150-1375
PL01-12x190/140-L	slider "standard L"	0150-1478
PL01-12x270/170-L	slider "standard L"	0150-1393
PL01-12x290/240-L	slider "standard-L"	0150-1363
PL01-12x350/300-L	slider "standard L"	0150-1479
PL01-12x420/370-L	slider "standard-L"	0150-1394
PL01-12x580/530-L	slider "standard-L"	0150-1391
PL01-12x480/430-L	slider "standard-L"	0150-1491
PL01-12x760/710-L	Slider "standard-L"	0150-1392

Item	Description	Part Number
PL01-20x240/160-L	slider "standard L"	0150-1350
PL01-20x300/220-L	slider "standard L"	0150-1351
PL01-20x305/160-L	slider "standard L"	0150-1352
PL01-20x365/220-L	slider "standard L"	0150-1353
PL01-20x395/320-L	slider "standard L"	0150-1354
PL01-20x500/420-L	slider "standard L"	0150-1358
PL01-20x600/520-L	slider "standard L"	0150-1359
PL01-20x700/620-L	slider "standard L"	0150-1360
PL01-20x800/720-L	slider "standard L"	0150-1361
PL01-20x900/820-L	slider "standard L"	0150-1362
PL01-28x350/270-L	slider 'standard L'	0150-1475
PL01-28x410/330-L	slider 'standard L'	0150-1476
PL01-28x500/420 L	slider 'standard L'	0150-1480
PL01-28x620/540-L	slider 'standard L'	0150-1481
PL01-28x710/630-L	slider 'standard L'	0150-1482
PL01-28x800/720-L	slider 'standard L'	0150-1483
PL01-28x920/840-L	slider 'standard L'	0150-1484
MOUNTING PARTS AND ACCESORIES FOR LINEAR MOTORS		
PF02-23x50	flange 23x50 mm	0150-2102
PF02-23x120	flange 23x120 mm	0150-2103
PF02-23x170	flange 23x170 mm	0150-2117
PF02-37x100	flange 37x100 mm	0150-1998
PF02-37x140	flange 37x140mm	0150-2105
PF02-37x200	flange 37x200mm	0150-1999
PF01-48x120	flange 48x120 mm	0150-1976
PF01-48x226	flange 48x226 mm	0150-2108
PF01-48x346	flange 48x346 mm	0150-2145
HV01-23	Fan cooling for H01-23	0150-5050
HV01-37/48	Fan cooling for H01-37/48 & PF01-48	0150-5051
PLF01-12	Fixed End Washer Set for 12 mm sliders	0150-3085
PLF01-20	Fixed End Washer Set for 20 mm sliders	0150-3083
PLF01-28	Fixed End Washer Set for 28 mm sliders	0150-3087
PLL02-12	Floating Bearing (replaces PLL01-12)	0150-3111
PLL01-20	Floating Bearing for 20 mm sliders	0150-3084
PLL01-28	Floating Bearing for 28 mm sliders	0150-3094
PLL01-27	Floating Bearing for 27 mm sliders	0150-3294
PLM01-20-MK	Mounting Kit for 20 mm sliders	0150-3079
PLM01-28-MK	Mounting Kit for 28 mm sliders	0150-3095
MCF01-C	Mounting clips for C-Connector	0150-3151
MCP01-18	Shrink Tube with heat activated sealant	0150-3089
WIPER/SEALINGS FOR LINEAR MOTORS		
PA01-23/12-F-2	Seal front side for PS01-23x...	0150-3293
PA01-37/19-F	Seal front side for PS01-37x...	0150-3225
PA01-37/19-R	Seal back side for PS01-37x...-C	0150-3226
PA01-37/19-R cable	Seal back side for PS01-37-cable typ	0150-3227
PA01-37/20-F	Seal front side for PS01-37x...	0150-3126
PA01-37/20-R	Seal back side for PS01-37x...-C	0150-3201
PA01-37/20-R cable	Seal back side for PS01-37-cable typ	0150-3221
PA01-48/27-F	Seal front side for PS01-48x...	0150-3228
PA01-48/27-R	Seal back side for PS01-48x...-C	0150-3229
PA01-48/28-F	Seal front side for PS01-48x...	0150-3127
PA01-48/28-R	Seal back side for PS01-48x...-C	0150-3202
PLAIN BUSHINGS FOR STAINLESS STEEL MOTORS IP69K		
PB01-37x24-P-SSC	Bearing for PS01-37x...-SSC (Stainless)	0150-3290
PB01-48x25-P-SSC	Bearing for PS01-48x...-SSC (Stainless)	0150-3281
PB01-48x25-80-P-SSC	Bearing for PS01-48x360-SSC (Stainless)	0150-3413
PB02-37x24-P-WD	Bearing for PS01-37x...-SSC	0150-3299
PB02-48x25-P-WD	Bearing for PS01-48x...-SSC	0150-3271
LUBRICANT FOR LINEAR MOTORS		
LU02-50	Lubricant for linear motors (50ml)	0150-1954
LU02-1000	Lubricant for linear motors (1000ml)	0150-1955
LU04-50	Lubricant for HP linear motors (50g)	0150-2135
LU04-1000	Lubricant for HP linear motors (1000g)	0150-2136
H01-LINEAR GUIDES WITH BALL BEARINGS)		
H01-23x86/60	H-Guide for P01-23x80, Stroke max 60mm	0150-5014
H01-23x86/160	H-Guide for P01-23x80, Stroke max 160mm	0150-5015
H01-23x86/260	H-Guide for P01-23x80, Stroke max 260mm	0150-5016
H01-23x166/80	H-Guide for P01-23x160, Stroke max 80mm	0150-5017
H01-23x166/180	H-Guide for P01-23x160, Stroke max 180mm	0150-5018
H01-23x166/280	H-Guide for P01-23x160, Stroke max 280mm	0150-5019
H01-37x166/80	H-Guide for P01-37x120, Stroke max 80mm	0150-5020
H01-37x166/180	H-Guide for P01-37x120, Stroke max 180mm	0150-5021
H01-37x166/280	H-Guide for P01-37x120, Stroke max 280mm	0150-5022
H01-37x286/60	H-Guide for P01-37x240, Stroke max 60mm	0150-5023
H01-37x286/160	H-Guide for P01-37x240, Stroke max 160mm	0150-5024
H01-37x286/260	H-Guide for P01-37x240, Stroke max 260mm	0150-5025
H01-48x250/120	H-Guide for P01-48x240, Stroke max 120mm	0150-5100
H01-48x250/210	H-Guide for P01-48x240, Stroke max 210mm	0150-5101
H01-48x250/330	H-Guide for P01-48x240, Stroke max 330mm	0150-5102
H01-48x250/420	H-Guide for P01-48x240, Stroke max 420mm	0150-5103
H01-LINEAR GUIDES WITH PLAIN BEARINGS		
H01-23x86/60-GF	H-Guide for P01-23x80, Stroke max 60mm	0150-5074
H01-23x86/160-GF	H-Guide for P01-23x80, Stroke max 160mm	0150-5075
H01-23x86/260-GF	H-Guide for P01-23x80, Stroke max 260mm	0150-5076
H01-23x166/80-GF	H-Guide for P01-23x160, Stroke max 80mm	0150-5077
H01-23x166/180-GF	H-Guide for P01-23x160, Stroke max 180mm	0150-5078
H01-23x166/280-GF	H-Guide for P01-23x160, Stroke max 280mm	0150-5079
H01-37x166/80-GF	H-Guide for P01-37x120, Stroke max 80mm	0150-5080

Item	Description	Part Number
H01-37x166/180-GF	H-Guide for P01-37x120, Stroke max 180mm	0150-5081
H01-37x166/280-GF	H-Guide for P01-37x120, Stroke max 280mm	0150-5082
H01-37x286/60-GF	H-Guide for P01-37x240, Stroke max 60mm	0150-5083
H01-37x286/160-GF	H-Guide for P01-37x240, Stroke max 160mm	0150-5084
H01-37x286/260-GF	H-Guide for P01-37x240, Stroke max 260mm	0150-5085
H01-48x250/120-GF	H-Guide for P01-48x240, Stroke max 120mm	0150-5104
H01-48x250/210-GF	H-Guide for P01-48x240, Stroke max 210mm	0150-5105
H01-48x250/330-GF	H-Guide for P01-48x240, Stroke max 330mm	0150-5106
H01-48x250/420-GF	H-Guide for P01-48x240, Stroke max 420mm	0150-5107
B01-LINEAR GUIDES WITH BALL BEARINGS		
B01-37x166/160	B-Guide for P01-37x120, Stroke max 160mm	0150-5138
B01-37x166/260	B-Guide for P01-37x120, Stroke max 260mm	0150-5139
B01-37x166/360	B-Guide for P01-37x120, Stroke max 360mm	0150-5140
B01-37x286/140	B-Guide for P01-37x240, Stroke max 140mm	0150-5144
B01-37x286/240	B-Guide for P01-37x240, Stroke max 240mm	0150-5145
B01-37x286/340	B-Guide for P01-37x240, Stroke max 340mm	0150-5146
B01-48x250/90	B-Guide for P01-48x240, Stroke max 90mm	0150-5150
B01-48x250/180	B-Guide for P01-48x240, Stroke max 180mm	0150-5151
B01-48x250/300	B-Guide for P01-48x240, Stroke max 300mm	0150-5152
B01-48x250/390	B-Guide for P01-48x240, Stroke max 390mm	0150-5153
B01-LINEAR GUIDES WITH PLAIN BEARINGS		
B01-37x166/160-GF	B-Guide for P01-37x120, Stroke max 160mm	0150-5141
B01-37x166/260-GF	B-Guide for P01-37x120, Stroke max 260mm	0150-5142
B01-37x166/360-GF	B-Guide for P01-37x120, Stroke max 360mm	0150-5143
B01-37x286/140-GF	B-Guide for P01-37x240, Stroke max 140mm	0150-5147
B01-37x286/240-GF	B-Guide for P01-37x240, Stroke max 240mm	0150-5148
B01-37x286/340-GF	B-Guide for P01-37x240, Stroke max 340mm	0150-5149
B01-48x250/90-GF	B-Guide for P01-48x240, Stroke max 90mm	0150-5154
B01-48x250/180-GF	B-Guide for P01-48x240, Stroke max 180mm	0150-5155
B01-48x250/300-GF	B-Guide for P01-48x240, Stroke max 300mm	0150-5156
B01-48x250/390-GF	B-Guide for P01-48x240, Stroke max 390mm	0150-5157
ACCESSORIES FOR LINEAR GUIDES (FAN SEE MOTOR ACCESSORIES)		
HB01-37	Pneumatic brake for H01-37 guides	0150-5052
HB01-48	Pneumatic brake for H01-48 guides	0150-5098
HA01-37/20-F	Wiper for H01-37 guides, front side	0150-5108
HA01-37/19-F	Wiper for B01-37 guides, front side	0150-5177
HA01-48/28-F	Wiper for H01-48 guides, front side	0150-5109
HA01-48/27-F	Wiper for B01-48 guides, front side	0150-5178
Servo Drives SERIES E100/1001		
E100-AT	AnalogTrigger Drive 1 Axis (48V/3A)	0150-1601
E200-AT	AnalogTrigger Drive 2 Axis (48V/3A)	0150-1602
E400-AT	AnalogTrigger Drive 4 Axis (48V/3A)	0150-1604
E1001-AT	AnalogTrigger Drive 1 Axis (72V/8A)	0150-2300
E2001-AT	AnalogTrigger Drive 2 Axis (72V/8A)	0150-2301
E4001-AT	AnalogTrigger Drive 4 Axis (72V/8A)	0150-2303
Servo Drives SERIES E100/1001 (continued)		
E100-MT	Multi Trigger Drive 1 Axis (48V/3A)	0150-1611
E200-MT	Multi Trigger Drive 2 Axis (48V/3A)	0150-1612
E400-MT	Multi Trigger Drive 4 Axis (48V/3A)	0150-1614
E1001-MT	Multi Trigger Drive 1 Axis (72V/8A)	0150-2304
E2001-MT	Multi Trigger Drive 2 Axis (72V/8A)	0150-2305
E4001-MT	Multi Trigger Drive 4 Axis (72V/8A)	0150-2307
Servo Drives SERIES E100/1001 (continued)		
E100-CO	CanOpen Drive 1 Axis (48V/3A)	0150-1669
E200-CO	CanOpen Drive 2 Axis (48V/3A)	0150-1670
E400-CO	CanOpen Drive 4 Axis (48V/3A)	0150-1672
E1001-CO	CanOpen Drive 1 Axis (72V/8A)	0150-2308
E2001-CO	CanOpen Drive 2 Axis (72V/8A)	0150-2309
E4001-CO	CanOpen Drive 4 Axis (72V/8A)	0150-2311
Servo Drives SERIES E100/1001 (continued)		
E100-DN	DeviceNet Drive 1 Axis (48V/3A)	0150-1641
E200-DN	DeviceNet Drive 2 Axis (48V/3A)	0150-1642
E400-DN	DeviceNet Drive 4 Axis (48V/3A)	0150-1644
E1001-DN	DeviceNet Drive 1 Axis (72V/8A)	0150-2312
E2001-DN	DeviceNet Drive 2 Axis (72V/8A)	0150-2313
E4001-DN	DeviceNet Drive 4 Axis (72V/8A)	0150-2315
Servo Drives SERIES E100/1001 (continued)		
E130-DP	Profibus DP Drive 1 Axis (48V/3A)	0150-1621
E230-DP	Profibus DP Drive 2 Axis (48V/3A)	0150-1622
E430-DP	Profibus DP Drive 4 Axis (48V/3A)	0150-1624
E1031-DP	Profibus DP Drive 1 Axis (72V/8A)	0150-2316
E2031-DP	Profibus DP Drive 2 Axis (72V/8A)	0150-2317
E4031-DP	Profibus DP Drive 4 Axis (72V/8A)	0150-2319
Servo Drives SERIES B1100		
B1100-PP	Point to Point Drive (72V/8A)	0150-1735
B1100-PP-HC	Point to Point Drive (72V/15A)	0150-1736
B1100-PP-XC	Point to Point Drive (72V/25A)	0150-1740
B1100-VF	Force Velocity Drive (72V/8A)	0150-1685
B1100-VF-HC	Force Velocity Drive (72V/15A)	0150-1686
B1100-VF-XC	Force Velocity Drive (72V/25A)	0150-1739
B1100-GP	General Purpose Drive (72V/8A)	0150-1737
B1100-GP-HC	General Purpose Drive (72V/15A)	0150-1738
B1100-GP-XC	General Purpose Drive (72V/25A)	0150-1741
Servo Drive SERIES B1100 INDUSTRIAL ETHERNET		
B1150-ML	MC-Link Drive (72V/8A)	0150-1796
B1150-ML-HC	MC-Link Drive (72V/15A)	0150-1797
B1150-ML-XC	MC-Link Drive (72V/25A)	0150-1798
B8050-ML-EC	8-Axes Bus Module EtherCAT	0150-1878
B8050-ML-IP	8-Axes Bus Module Ethernet IP	0150-1879
B8050-ML-PL	8-Axes Bus Module Powerlink	0150-1877
B8050-ML-PN	8-Axes Bus Module Profinet	0150-1880
B8050-ML-SC	8-Axes Bus Module Sercos III	0150-1881

Item	Description	Part Number
B8050-ML-SC	8-Axes Bus Module Sercos III	0150-2020
Servo Drives SERIES E1100		
E1100-RS	RS232/485 Drive (72V/8A)	0150-1677
E1100-RS-HC	RS232/485 Drive (72V/15A)	0150-1678
E1100-RS-XC	RS232/485 Drive (72V/25A)	0150-1862
E1100-CO	CANopen Drive (72V/8A)	0150-1681
E1100-CO-HC	CANopen Drive (72V/15A)	0150-1682
E1100-CO-XC	CANopen Drive (72V/25A)	0150-1683
E1100-DN	DeviceNet Drive (72V/8A)	0150-1679
E1100-DN-HC	DeviceNet Drive (72V/15A)	0150-1680
E1100-DN-XC	DeviceNet Drive (72V/25A)	0150-1863
E1130-DP	Profibus DP Drive (72V/8A)	0150-1667
E1130-DP-HC	Profibus DP Drive (72V/15A)	0150-1668
E1130-DP-XC	Profibus DP Drive (72V/25A)	0150-1861
E1100-GP	General Purpose Drive (72V/8A)	0150-1665
E1100-GP-HC	General Purpose Drive (72V/15A)	0150-1666
E1100-GP-XC	General Purpose Drive (72V/25A)	0150-1864
Servo Drives SERIES E1200		
E1200-GP-UC	General Purpose Drive (72V/32A)	0150-1771
E1230-DP-UC	Profibus DP Drive (72V/32A)	0150-1766
E1250-EC-UC	EtherCAT Drive (72V/32A)	0150-1763
E1250-SE-UC	EtherCAT SoE Drive (72V/32A)	0150-1898
E1250-IP-UC	Ethernet/IP Drive (72V/32A)	0150-1761
E1250-PL-UC	Powerlink Drive (72V/32A)	0150-1760
E1250-PN-UC	ProfiNet Drive (72V/32A)	0150-1762
E1250-SC-UC	Sercos III Drive (72V/32A)	0150-1764
SWITCHED MODE POWER SUPPLIES		
S01-24/150	Power Supply 24V/150W	0150-1944
S01-24/300	Power Supply 24V/300W	0150-1945
S01-48/150	Power Supply 48V/150W for E100/E200	0150-1940
S01-48/300	Power Supply 48V/300W for E400	0150-1941
S01-48/600	Power Supply 48V/600W	0150-1946
S01-72/300	Power Supply 72V/300W for E1000/E2000	0150-1942
S01-72/600	Power Supply 72V/600W for E4000	0150-1943
S01-72/500	Power Supply 72V/500W, 1x120/230VAC	0150-1874
S01-72/1000	72V/1000W, 3x340-550VAC	0150-1872
SM01-150	Mounting part for power supply 150W	0150-3039
SM01-300	Mounting part for power supply 300 W	0150-3040
SM01-600	Mounting part for power supply 600W	0150-3041
TRANSFORMATOR SUPPLIES		
T01-72/420-Multi	T-Supply 420VA, 3x230/400/480VAC	0150-1869
T01-72/900-Multi	T-Supply 900VA, 3x230/400/480 VAC	0150-1870
T01-72/1500-Multi	T-Supply 1500VA, 3x230/400/480 VAC	0150-1871
T01-72/420-US	T-Supply 420VA, 3x380/400/420VAC	0150-1966
T01-72/420-US	T-Supply 420VA, 3x220/230/240VAC	0150-1967
T01-72/420-1ph	T-Supply 420VA, 1x208/220/230/240VAC	0150-1859
TF01-80V/15A	blade fuse for T01-72/420 (-US)	0150-1850
TF01-80V/30A	blade fuse for T01-72/900 & 1500 (-US)	0150-1851
ACCESSORIES FOR Servo Drives		
B01-4 230V / 50Hz	control box for 4 drives (incl. cables)	0150-1930
B01-4 115 V / 60 Hz	control box for 4 drives (incl. cables)	0150-1931
B01-E1100 24VDC	control box for E1100 (incl. cables)	0150-1970
B01-B1100 24VDC	control box for B1100 (incl. cables)	0150-2110
M01-DSUB25	Breakout Module for DSUB25	0150-2142
M01-digital	Breakout Module digital	0150-1932
M01-analog	Breakout Module analog	0150-1933
M01-Connector	Cables and Connectors	0150-1934
RS232 PC config. cable 2m	for E100/E1001	0150-3009
RS232 PC config. cable 2m	for E100/E1001/E1100/B1100	0150-3307
RS232 PC config. cable 2.5m	for E1200/E1400	0150-2143
USB-Serial Converter	USB to 9-pin RS-232 Serial Converter	0150-3110
USB-CAN Converter	USB to CAN Converter for E1100	0150-3134
RJ45-08/0.3	RJ45 patch cable 0.3m for E1100	0150-1852
RJ45-08/0.6	RJ45 crossover patch cable 0.6m	0150-1853
RJ45/RJ45-0.2-ML1	MC-Link Cable 0.2m	0150-3308
RR01-10/60	Regeneration Resistor 60W for E1100	0150-3088
RR01-68/100	Regeneration Resistor 100W for E1400	0150-3373
Capacitor 10'000uF/100V	with mounting material	0150-3075
OPTION: EXTERNAL POSITION SENSOR		
MS01-1/D	Linear Encoder 1um, A/B(for 1mm strip)	0150-1840
MB01-1000	Magnetic strip 1mm pitch per cm	0150-1963
MOTOR CABLE ASSEMBLED STANDARD		
K05-D/D-2	motor cable D/D, 2 m	0150-1910
K05-D/D-4	motor cable D/D, 4 m	0150-1911
K05-D/D-6	motor cable D/D, 6 m	0150-1912
K05-D/D-8	motor cable D/D, 8 m	0150-1913
K05-D/P-0.25	adapter cable D/P, 0.25m	0150-1921
K05-D/P-2	motor cable D/P, 2 m	0150-1949
K05-D/P-4	motor cable D/P, 4 m	0150-1995
K05-D/P-6	motor cable D/P, 6 m	0150-1994
K05-D/R-2	motor cable D/R, 2 m	0150-1832
K05-D/R-4	motor cable D/R, 4 m	0150-1833
K05-D/R-6	motor cable D/R, 6 m	0150-1834
K05-D/R-8	motor cable D/R, 8 m	0150-1835
K05-D/C-2	motor cable D/C, 2 m	0150-1819
K05-D/C-4	motor cable D/C, 4 m	0150-1820
K05-D/C-6	motor cable D/C, 6 m	0150-1821
K05-D/C-8	motor cable D/C, 8 m	0150-1822

Item	Description	Part Number
K05-P/D-0.4	adapter cable P/D, 0.4 m	0150-1922
K05-P/P-2	motor cable P/P, 2 m	0150-1915
K05-P/P-4	motor cable P/P, 4 m	0150-1916
K05-P/P-6	motor cable P/P, 6 m	0150-1917
K05-P/P-8	motor cable P/P, 8 m	0150-1918
K05-P/C-2	motor cable P/C, 2 m	0150-1818
K05-P/C-4	motor cable P/C, 4 m	0150-1804
K05-P/C-6	motor cable P/C, 6 m	0150-1805
K05-P/C-8	motor cable P/C, 8 m	0150-1806
K05-W/R-2	motor cable W/R, 2 m	0150-2119
K05-W/R-4	motor cable W/R, 4 m	0150-2120
K05-W/R-6	motor cable W/R, 6 m	0150-2121
K05-W/R-8	motor cable W/R, 8 m	0150-2122
K05-W/C-2	motor cable W/C, 2 m	0150-2123
K05-W/C-2	motor cable W/C, 2 m	0150-2296
K05-W/C-2	motor cable W/C, 2 m	0150-2297
K05-W/C-2	motor cable W/C, 2 m	0150-2298
K05-W/C-2	motor cable W/C, 2 m	0150-2299
K05-W/C-4	motor cable W/C, 4 m	0150-2124
K05-W/C-6	motor cable W/C, 6 m	0150-2125
K05-W/C-8	motor cable W/C, 8 m	0150-2126
K05-W/D-0.4	adapter cable W/D, 0.4 m	0150-1947
K05-W/P-0.4	adapter cable W/P, 0.4 m	0150-1948
K15-W/C-2	motor cable W/C, 2 m	0150-1811
K15-W/C-4	motor cable W/C, 4 m	0150-1801
K15-W/C-5	motor cable W/C, 5 m	0150-1849
K15-W/C-6	motor cable W/C, 6 m	0150-1802
K15-W/C-8	motor cable W/C, 8 m	0150-1803
MOTOR CABLE ASSEMBLED HIGH FLEX		
KS05-D/D-2	trailing chain cable D/D, 2 m	0150-1988
KS05-D/D-4	trailing chain cable D/D, 4 m	0150-1989
KS05-D/R-2	trailing chain cable D/R, 2 m	0150-1854
KS05-D/R-4	trailing chain cable D/R, 4 m	0150-1836
KS05-D/R-6	trailing chain cable D/R, 6 m	0150-1855
KS05-D/R-8	trailing chain cable D/R, 8 m	0150-1837
KS05-D/C-2	trailing chain cable D/C, 2 m	0150-1856
KS05-D/C-4	trailing chain cable D/C, 4 m	0150-1823
KS05-D/C-6	trailing chain cable D/C, 6 m	0150-1857
KS05-D/C-8	trailing chain cable D/C, 8 m	0150-1824
KS05-P/P-2	trailing chain cable P/P, 2 m	0150-1990
KS05-P/P-4	trailing chain cable P/P, 4 m	0150-1991
KS05-P/C-4	trailing chain cable P/C, 4 m	0150-1809
KS05-P/C-8	trailing chain cable P/C, 8 m	0150-1810
KS05-R/R-2	trailing chain cable R/R, 2 m	0150-1838
KS05-R/R-4	trailing chain cable R/R, 4 m	0150-1839
KS05-W/C-4	trailing chain cable W/C, 4 m	0150-2127
KS05-W/C-6	trailing chain cable W/C, 6 m	0150-2128
KS05-W/C-8	trailing chain cable W/C, 8 m	0150-2129
KS05-W/R-4	trailing chain cable W/R, 4m	0150-2106
KS05-W/R-6	trailing chain cable W/R, 6 m	0150-2131
KS05-W/R-8	trailing chain cable W/R, 8m	0150-2107
KS05-C/C-2	trailing chain cable C/C, 2m	0150-1827
KS05-C/C-4	trailing chain cable C/C, 4 m	0150-1828
KS10-C/C-2	trailing chain cable C/C, 2 m	0150-1816
KS10-C/C-4	trailing chain cable C/C, 4 m	0150-1817
KS10-W/C-4	trailing chain cable W/C, 4 m	0150-1807
KS10-W/C-5	trailing chain cable W/C, 5 m	0150-1860
KS10-W/C-6	trailing chain cable W/C, 6 m	0150-1858
KS10-W/C-8	trailing chain cable W/C, 8 m	0150-1808
MOTOR CABLE FOR SHORT MOTOR P02-23Sx80-F		
KF02-D15/F-0.70	flat cable 0.7m, for PS02-23Sx80-F	0150-2158
KF02-D15/F-0.48	flat cable 0.48m, for PS02-23Sx80-F	0150-2154
KF02-D15/F-0.32	flat cable 0.32m, for PS02-23Sx80-F	0150-2152
KF02-D15/F-0.16	flat cable 0.16m, for PS02-23Sx80-F	0150-2156
KF02-D15/F-0.08	flat cable 0.08m, for PS02-23Sx80-F	0150-2150
K05-D/D15-1	adapter cable D/D15,1m (for PS02-23Sx80)	0150-1936
MOTOR CABLE FOR SHORT MOTOR P02-23Sx80F-HP-K		
KS03-W/K-2	trailing chain cable W/K, 2m	0150-2187
KS03-R/K-1	trailing chain cable R/K, 1m	0150-2185
KS03-R/K-2	trailing chain cable R/K, 2m	0150-2186
MOTOR CABLE PER M		
K05-04/05	motor cable per m	0150-1920
K05-04/05-50	motor cable 50m roll	0150-1956
K05-04/05-100	motor cable 100m roll	0150-1957
K05-04/05-200	motor cable 200m roll	0150-1958
K15-04/05	motor cable per m	0150-1978
K15-04/05-100	motor cable, 100 m roll	0150-1969
KS03-09	trailing chain cable per m (max. 2m)	0150-2182
KS05-04/05	trailing chain cable (per m)	0150-1938
KS05-04/05-100	trailing chain cable 100 m roll	0150-1959
KS10-04/05	trailing chain cable per m	0150-1977
KS10-04/05-100	trailing chain cable, 100m roll	0150-1968
KR05-04/05	robotic cable (per m)	0150-1846
KR05-04/05-100	robotic cable, 100m roll	0150-1847
KR10-04/05	robotic cable (per m)	0150-1830
KR10-04/05-100	robotic cable, 100m roll	0150-1831
MOTOR CONNECTORS, ASSEMBLED CONNECTORS		
MC01-D/m	motor connector D (m)	0150-3024
MC01-D/f	motor connector D (f)	0150-3025
MC01-D15/f	motor connector D15/f	0150-3136
MC01-K/f	motor connector K (f)	0150-3345
MC01-P/m	motor connector P (m)	0150-3020
MC01-P/f	motor connector P(f)	0150-3021

Item	Description	Part Number
MC01-R/m	motor connector R/m	1510-3130
MC01-R/f	motor connector R/f	1510-3129
MC01-C/m	motor connector C/m	1510-3093
MC01-C/f	motor connector C/f	1510-3080
MC01-W/m	motor connector W/m	1510-3140
MC01-D/m-as	D/m-connector assembled	1510-3055
MC01-D/f-as	D/f-connector assembled	1510-3142
MC01-D15/m-as	D15/m-connector assembled	1510-3148
MC01-D15/f-as	D15/f-connector assembled	1510-3073
MC01-K/f-as	K/f-connector assembled	1510-3346
MC01-P/m-as	P/m-connector assembled	1510-3056
MC01-P/f-as	P/f-connector assembled	1510-3144
MC01-R/m-as	R/m-connector assembled	1510-3097
MC01-R/f-as	R/f-connector assembled	1510-3143
MC01-N/f-as	N/f-connector assembled	1510-3408
MC01-C/m-as	C/m-connector assembled	1510-3099
MC01-C/f-as	C/f-connector assembled	1510-3146
MC01-W/m-as	W/m-connector assembled	1510-3147
MC01-F/R	mounting flange for connector MC01-R	1510-3253
MC01-F/C	mounting flange for connector MC01-C	1510-3254
MC01-R/m-cap	metal protection cap for R/m	1510-3376
MC01-R/f-cap	metal protection cap for R/f	1510-3377
MC01-C/m-cap	metal protection cap for C/m	1510-3378
MC01-C/f-cap	metal protection cap for C/f	1510-3379
MOTOR CONNECTORS IP69K, ASSEMBLED CONNECTORS IP69K		
MC01-R/f-IP69K	motor connector R/f, IP69K	1510-3341
MC01-R/f-IP69K-as	motor connector R/f, IP69K, assembled	1510-3342
MC01-C/f-IP69K	motor connector C/f, IP69K	1510-3339
MC01-C/f-IP69K-as	motor connector C/f, IP69K, assembled	1510-3340
MC01-R/f-IP69K-SSC	motor connector R/f, IP69K, SSC	1510-3347
MC01-R/f-IP69K-SSC-as	motor connector R/f, IP69K, SSC, assembled	1510-3343
MC01-C/f-IP69K-SSC	motor connector C/f, IP69K, SSC	1510-3306
MC01-C/f-IP69K-SSC-as	motor connector C/f, IP69K, SSC, assembled	1510-3325
Servo Drive SERIES E1400 (3x400...480VAC)		
E1400-GP-QN	General Purpose Drive (3x400V/28A)	1510-1779
E1430-DP-QN	Profibus DP Drive (3x400V/28A)	1510-1786
E1450-EC-QN	EtherCAT Drive (3x400V/28A)	1510-1784
E1450-SE-QN	EtherCAT SoE Drive (3x400V/28A)	1510-1899
E1450-IP-QN	Ethernet/IP Drive (3x400V/28A)	1510-1782
E1450-PL-QN	PowerLink Drive (3x400V/28A)	1510-1791
E1450-PN-QN	ProfNet Drive (3x400V/28A)	1510-1783
E1450-SC-QN	Sercos III Drive (3x400V/28A)	1510-1785
STATOR SERIES PS10-70 FOR LINEAR MOTORS (3x400...480VAC)		
PS10-70x80	stator 3x400VAC, LinMot Encoder	1510-1291
PS10-70x160	stator 3x400VAC, LinMot Encoder	1510-1292
PS10-70x240	stator 3x400VAC, LinMot Encoder	1510-1293
PS10-70x320	stator 3x400VAC, LinMot encoder	1510-1284
PS10-70x400	stator 3x400VAC, LinMot Encoder	1510-1294
PS10-70x80-D01	Stator 3x400VAC, Sin/Cos encoder 1Vpp	1510-2282
PS10-70x160-D01	Stator 3x400VAC, Sin/Cos encoder 1Vpp	1510-2283
PS10-70x240-D01	Stator 3x400VAC, Sin/Cos encoder 1Vpp	1510-2284
PS10-70x320-D01	Stator 3x400VAC, Sin/Cos encoder 1Vpp	1510-2285
PS10-70x320-D02	Stator 3x400VAC, Sin/Cos encoder 1Vpp	1510-2343
PS10-70x400-D01	Stator 3x400VAC, Sin/Cos encoder 1Vpp	1510-2286
SLIDER SERIES PL10-28 FOR LINEAR MOTORS (3x400...480VAC)		
PL10-28x290/240	Slider for P10-70 "standard"	1510-2193
PL10-28x390/340	Slider for P10-70 "standard"	1510-2194
PL10-28x490/440	Slider for P10-70 "standard"	1510-2195
PL10-28x590/540	Slider for P10-70 "standard"	1510-2196
PL01-28x690/640	Slider for P10-70 "standard"	1510-2197
PL10-28x790/740	Slider for P10-70 "standard"	1510-2198
PL10-28x890/840	Slider for P10-70 "standard"	1510-2199
PL10-28x990/940	Slider for P10-70 "standard"	1510-2203
PL10-28x1190/1140	Slider for P10-70 "standard"	1510-2204
PL10-28x1390/1340	Slider for P10-70 "standard"	1510-2205
PL10-28x1590/1540	Slider for P10-70 "standard"	1510-2206
PL10-28x1790/1740	Slider for P10-70 "standard"	1510-2207
PL10-28x1990/1940	Slider for P10-70 "standard"	1510-2208
FLANGES PF10-70 FOR LINEAR MOTORS P10-70 (3x400...480VAC)		
PF10-70x110	flange for PS10-70x80	1510-2272
PF10-70x190	flange for PS10-70x160	1510-2273
PF10-70x270	flange for PS10-70x240	1510-2274
PF10-70x350	flange for PS10-70x320	1510-2290
PF10-70x430	flange for PS10-70x400	1510-2276
PF10-70x110-FC	flange for PS10-70x80 fluid cooling	1510-2291
PF10-70x190-FC	flange for PS10-70x160 fluid cooling	1510-2292
PF10-70x270-FC	flange for PS10-70x240 fluid cooling	1510-2293
PF10-70x350-FC	flange for PS10-70x320 fluid cooling	1510-2294
PF10-70x400-FC	flange for PS10-70x400 fluid cooling	1510-2295
POWER & ENCODER CABLE FOR LINEAR MOTORS P10-70 (3x400...480VAC)		
KPS15-04-L/Q-3	power trailing chain cable L/Q, 3m	1510-2266
KPS15-04-L/Q-5	power trailing chain cable L/Q, 5m	1510-2261
KPS15-04-L/Q-8	power trailing chain cable L/Q, 8m	1510-2267
KPS15-04-L/Q-12	power trailing chain cable L/Q, 12m	1510-2268
KSS05-02/08-D15/J-3	encoder trailing chain cable D15/J, 3m	1510-2263
KSS05-02/08-D15/J-5	encoder trailing chain cable D15/J, 5m	1510-2262
KSS05-02/08-D15/J-8	encoder trailing chain cable D15/J, 8m	1510-2264
KSS05-02/08-D15/J-12	encoder trailing chain cable D15/J, 12m	1510-2265

Item	Description	Part Number
CABLE AND CONNECTORS FOR LINEAR MOTORS P10-70 (3x400...480VAC)		
KPS15-04	trailing chain cable power (per m)	0150-2257
KSS05-02/08	trailing chain cable encoder (per m)	0150-2258
MC10-L/m	Drive connector power MC10-L/m	0150-3382
MC10-Q/m	Motor connector Q/m	0160-2405
MC10-Q/f	Motor connector MC10-Q/f	0160-2268
MC10-D15-45*/f	Drive connector encoder D15-45*/f	0150-3397
MC10-J17/m	Motor connector encoder MC10-J17/m	0160-2407
MC10-J/f	Motor connector encoder MC10-J/f	0160-2269
MC10-L/m-as	Connector L/m assembled	0160-2330
MC10-Q/m-as	Connector Q/m assembled	0160-2406
MC10-Q/f-as	Connector Q/f assembled	0160-2329
MC10-D15-45*/f-as	Connector D15-45*(f) assembled	0150-3399
MC10-J/m-as	Connector J/m assembled	0160-2408
MC10-J/f-as	Connector J/f assembled	0160-2331
ACCESSORIES FOR LINEAR MOTORS / Servo Drives (3x400...480VAC)		
EV01-E1400	Fan cooling kit for Drive series E1400	0150-5055
LINEAR-ROTARY-MOTORS		
PR01-52x40-R/37x120F-HP-C-80	Linear-Rotary-Actuator	0150-1573
PR01-52x60-R/37x120F-HP-C-100	Linear-Rotary-Actuator	0150-1197
PR01-84x80-C/48x240F-C-100	Linear-Rotary-Actuator	0150-1194
PR01-84x80-C/48x240F-C-100-L	Linear-Rotary-Actuator with hollow shaft	0150-1196
PR01-84x80-C/48x360F-C-100	Linear-Rotary-Actuator	0150-1199
PR01-84x80-C/48x360F-C-100-L	Linear-Rotary-Actuator with hollow shaft	0150-1200
ACCESSORIES FOR LINEAR-ROTARY-MOTORS		
PC01-37x68	Cooling Profile for PS01-37	0160-2131
PC01-48x100	Cooling Profile for PS01-48	0160-2145
PC01-48x117	Cooling Profile for PS01-48	0160-2138
RS01-VA52-Kit	Fan Kit for RS01-52 Rotary Motors	0150-1599
RS01-VA84-Kit	Fan Kit for RS01-84 Rotary Motors	0150-1600
MA01-PR01-52x40-37	Adapter MagSpring	0250-0121
MA01-PR01-70x40-37	Adapter MagSpring	0250-0120
MA01-PR01-70x40-37-L	Adapter MagSpring L-Type	0250-0124
MF01-PR01-52x40-37	Mounting Flange for MagSpring	0250-2319
MF01-PR01-70x40-37	Mounting Flange for MagSpring	0250-2318
RS01-SS12x22	Shaft-hub clamping for 12mm shaft	0230-0101
RS01-SS20x38	Shaft-hub clamping for 20mm shaft	0230-0100
MAGSPRING STATORS		
MS01-20x60	MagSpring Stator	0250-2200
MS01-20x140	MagSpring Stator	0250-2201
MS01-20x220	MagSpring Stator	0250-2202
MS01-20x300	MagSpring Stator	0250-2207
MS01-37x80	MagSpring Stator	0250-2203
MS01-37x155	MagSpring Stator	0250-2204
MS01-37x230	MagSpring Stator	0250-2205
MS01-37x305	MagSpring Stator	0250-2206
MAGSPRING SLIDERS		
ML01-12x130/80-10	MagSpring Slider	0250-2300
ML01-12x130/80-15	MagSpring Slider	0250-2308
ML01-12x130/80-20	MagSpring Slider	0250-2301
ML01-12x210/160-10	MagSpring Slider	0250-2302
ML01-12x210/160-15	MagSpring Slider	0250-2309
ML01-12x210/160-20	MagSpring Slider	0250-2303
ML01-12x290/240-10	MagSpring Slider	0250-2304
ML01-12x290/240-15	MagSpring Slider	0250-2310
ML01-12x290/240-20	MagSpring Slider	0250-2305
ML01-12x370/320-10	MagSpring Slider	0250-2311
ML01-12x370/320-15	MagSpring Slider	0250-2312
ML01-12x370/320-20	MagSpring Slider	0250-2313
MOUNTING MATERIAL FOR MAGSPRING		
MF01-20/H23	Flange MagSpring20/H-Guide23	0250-2306
MF01-20/H37	Flange MagSpring20/H-Guide37	0250-2315
MF01-37/H37	Flange MagSpring37/H-Guide37	0250-2307
MA01-20/H23	Adapter MagSpring20 /H-Guide23	0250-0116
MA01-37/H37	Adapter MagSpring37&20/H-Führung37	0250-0117
MA01-37/H48	Adapter MagSpring37/H-Guide48	0250-0118
MA01-37/H23	Adapter MagSpring37 /H-Guide23	0250-0122

General Sales and Delivery Conditions

1.1 The contract is concluded upon receipt of written confirmation from the supplier that he will accept the order (order confirmation). Proposals that do not contain an expiration date are non-binding.

1.2 These delivery conditions apply if they are declared as applicable in the proposal or in the order confirmation. Deviating buyer's conditions are valid only if they are accepted by the supplier expressly and in writing.

1.3 Item 1.2 also applies to any other provisions that are attached to the proposal or the order confirmation and declared as applicable therein. Such provisions override these delivery conditions in any case of deviation.

1.4 All agreements and legally enforceable declarations by the contractual parties must be in writing to be valid.

2. Scope of Delivery and Services

Goods and services from the supplier are listed in the order confirmation, including any attachments to it.

3. Drawings and Technical Documents

3.1 Brochures and catalogs are non-binding, absent any deviating agreement. Data in the supplier's technical documentation is binding only wherever it is expressly guaranteed.

3.2 Each contractual party retains all rights to drawings and technical document that it provides to the other party. The receiving contractual party recognized these rights, and will not make the documents available to third parties, in whole or in part, or use them for any other purpose than that for which they were intended, without prior written permission from the other contractual party.

4. Regulations in the country of destination and protective devices The buyer must make the seller aware, in a timely manner prior to ordering, of the regulations and standards that relate to the goods and services, the operation of the object of delivery, and accident and illness prevention, and that must be met in the country of destination. Protective devices are included in the scope of delivery, to the extent that this has been agreed to.

5. Prices

5.1 All prices are listed - unless otherwise agreed - FOB works, without packaging, in freely distributable Swiss francs, without any deductions. All additional costs, such as those for freight, insurance, export, transport, import, and other authorizations and registrations are borne by the buyer. The buyer must also pay any type of taxes, fees, duties, tolls, and the like that arise in connection with the contract, or must repay the seller for them upon presentation of evidence of payment, if the seller becomes responsible for paying them. If the supplier has included costs for packaging, freight, insurance, and other additional costs in its proposal or delivery price, or listed them separately in the proposal or order confirmation, then he is entitled to adjust his prices accordingly if the rates change.

5.2 The supplier retains the right to one price adjustment if a sliding price has been agreed to. An appropriate price adjustment also is done if the delivery lead time is extended afterward for one of the reasons listed in Item 8.2, or the type or scope of the contracted deliveries or services have been changed, or the documents provided by the buyer did not match the actual circumstances or were incomplete.

6. Payment terms

6.1 Payments are to be made in accordance with the agreed-upon payment conditions at the supplier's location, with no deduction of discounts, stipends, taxes, duties, fees, tolls, or the like. The payment obligation has been met as soon as the owed amount is freely available to the supplier at his location. Accreditive costs, bank charges and commissions, collection expenses, and, if payment in another currency has been agreed to, exchange fees and taxes, are to be borne by the buyer.

6.2 Payment dates are to be met even if transportation, delivery, installation, startup, or acceptance of the deliveries or services are delayed or made impossible for reasons that the supplier is not responsible for, or if non-critical parts are missing, or rework is needed that does not make use of the delivery impossible.

6.3 If the down payment or security to be provided at contract signing are not made in accordance with the contract, then the supplier is entitled to adhere to the contract, or to withdraw from the contract and, in both cases, require compensation for damages. If the buyer is in arrears on any other payment, for any reason, or if the supplier has reason to seriously fear, due to conditions arising after the contract is signed, that he will not receive payments in a timely manner, then the supplier is entitled, without relinquishing any legal rights, to discontinue further work on the contract, and to retain deliveries that are ready to ship until new payment and delivery terms are agreed to, and the supplier has received sufficient security. If such an agreement cannot be reached within a reasonable period, or if the supplier does not receive sufficient security, then he is entitled to withdraw from the contract and demand payment of damages.

6.4 If the buyer does not meet the contracted payment deadline, then he must pay, without further warning, interest from the due date forward at the typical rate of interest for the buyer's location, but at least 4% above the discount rate of the Schweizerischen Nationalbank. Additional recovery of damages is reserved.

7. Retention of Title

The supplier remains the owner of all deliveries in their entirety until payment has been made in full according to the contract. The buyer is obligated to cooperate with measures that are needed to protect the

property of the supplier, and to meet all formalities needed for justification and maintenance of the retention of title. The buyer will maintain and appropriately insure the delivered goods at his cost during the period of retention of title. He will also take any necessary steps to ensure that the suppliers' claim of ownership is neither infringed nor rescinded.

8. Delivery Lead Time

8.1 Delivery lead time begins as soon as the contract is concluded, all governmental formalities, such as import, export, transit, and payment authorizations have been received, the payment due upon order and any securities have been paid, and significant technical items have been clarified. The delivery lead time is met if, at the time it expires, notice of readiness to ship has been sent to the buyer.

8.2 The delivery lead time increases: a) if the supplier does not receive information needed to fulfill the contract in a timely manner, or if the buyer modifies them afterward and thus causes a delay in delivery or services; b) if obstacles arise that the supplier cannot overcome, despite applying necessary care, regardless of whether they are caused by him, the buyer, or third parties. Such obstacles include epidemic, mobilization, war, revolt, significant disruption of operations, accidents, labor conflicts, delayed or erroneous delivery of required raw materials, components, or semi-finished goods, scrapping of important components, official measures or injunctions, acts of nature; c) if the buyer or a third party is behind with the work that they are to carry out, or the buyer does not adhere to his contractual obligations, in particular the contracted payment conditions.

8.3 The buyer is entitled to obtain damages for late delivery, to the extent that a delay was probably caused by the supplier, and the buyer can demonstrate damages as a consequence of this delay. If the buyer is provided with a substitute delivery, then the claim for damages due to delay becomes invalid. Damages for delay are in the amount of no more than 1/2% for each full week of delay, but no more than 5%, based on the sales price FOB factory (without packaging) of the delayed part of the delivery.

For the first two weeks of delay, no claim of damages applies. After reaching the maximum damages for delay, the buyer is to set an appropriate new deadline for the supplier. If this new deadline is not met, due to the fault of the supplier, then the buyer is entitled to refuse to receive the delayed part of the delivery, if there are no longer grounds to expect it will be fulfilled. If a delay caused by the supplier and extending beyond the new deadline leads to an economically infeasible situation for the buyer, then he is entitled to withdraw from the contract and demand refund of all payments upon return of any deliveries received.

8.4 In case of delay in deliveries or services, the buyer has no rights or claims except for those listed explicitly in Item 8. This limitation does not apply in case of illegal intent or gross negligence by the supplier, unless these are on the part of his agents.

9. Packaging

Packaging is billed separately by the supplier, and will not be accepted for return unless this has been agreed to. In this case, the packaging must be returned by the buyer, at buyer's costs, to the point of origin.

10. Transfer of Risks and Benefits

10.1 Risks and benefits are transferred to the buyer no later than departure of the delivery from the plant.

10.2 If shipment is delay at the demand of the buyer, or for other reasons that are not the supplier's responsibility, then the risk is transferred to the buyer at the time that was originally planned for shipment from the plant. From this point forward, deliveries are stored and insured at the cost and risk of the buyer.

11. Shipment, Transportation, and Insurance

11.1 The supplier is to be informed of any special requests regarding shipment, transportation, and insurance in a timely manner. Transportation is at the cost and risk of the buyer. Claims regarding shipment or transportation are to be directed by the buyer to the last freight carrier immediately upon receipt of the delivery or freight documents.

11.2 Insurance against damages of any kind is the responsibility of the buyer. Even if it is to be obtained by the supplier, it is considered to be at the request, cost, and risk of the buyer.

12. Inspection and Acceptance of Deliveries and Services

12.1 The supplier will inspect the deliveries and services to the usual extent prior to shipment. If the buyer requires additional inspections, then these must be agreed upon and must be paid by the buyer. They will be done, to the extent that circumstances allow, at the supplier's factory.

12.2 The buyer is to inspect the deliveries and services within a reasonable period, and immediately inform the supplier in writing of any defects. If it neglects to do so, the deliveries and services are considered to be accepted and approved. For defects in deliveries or services that are not evident at this time, the claim rights of the buyer for warranty and liability for defects under Item 13 remain intact.

12.3 The supplier is to correct the defects of which it has been notified per Item 12.2, and the buyer is to provide the opportunity to do so.

12.4 An acceptance inspection, and determination of the applicable conditions for it, requires an appropriate agreement.

12.5 Acceptance is considered to have taken place if the contracted acceptance inspection cannot be carried out on the planned date for reasons for which the supplier is not responsible, or if the buyer decli-

nes the acceptance without being entitled to do so, or if the buyer refuses to sign a factual acceptance record, or as soon as the buyer makes use of the supplier's deliveries or services.

12.6 In case of defects in deliveries or services, the buyer has no rights or claims except for those listed explicitly in Item 12 or Item 13.

13. Warranty, Liability for Defects

13.1 The warranty period (guarantee period) is 12 months. It begins when the deliveries leave the plant, or upon any contracted acceptance of the deliveries and services, or upon completion of any supplier-provided installation, installation supervision, or commissioning. If shipment, acceptance, installation, installation supervision, or commissioning is delayed for reasons that are not the responsibility of the supplier, then the warranty period ends no later than 18 months after notice of readiness for shipment. The warranty period for replaced or repaired components starts anew, and lasts 6 months from the replacement, completion of repair, or upon acceptance, but no more than 12 months after the end of the warranty period provided under the previous paragraph. The warranty period ends prematurely if the buyer or a third party makes improper changes or repairs, or if the buyer, in case of a defect, does not immediately take all measures to minimize damages and give the supplier the opportunity to correct the defect.

13.2 The supplier agrees to repair or replace as soon as possible, at its discretion, upon written request by the buyer, all parts of the supplier's deliveries that can be shown to be defective or unusable, prior to the expiration of the warranty, due to bad material, defective design, or deficient manufacturing. Replaced parts become the property of the supplier. The supplier bears the costs of repair that are incurred at his plant, and of replacement of the defective parts. All costs beyond these are borne by the buyer.

13.3 The supplier provides technical application advice according to its best knowledge.

All statements and information regarding suitability and application of the goods, however, are non-binding, and do not relieve the buyer of its own inspections and experiments. The buyer is responsible for meeting legal requirements in the use of the deliveries. Guaranteed properties of the deliveries or services are only those that are explicitly indicated as such in the order confirmation or the contracted specifications. This guarantee is valid no longer than the end of the warranty period. For justified complaints of defects, the supplier has the right, at its discretion, either to repair the defect or to take back the goods with a credit for the billed amount, or to provide a replacement at no cost within a reasonable period, or to credit the buyer for the reduced value of the goods. Further claims are barred.

The supplier's liability is nullified in case of deliberate interference with the goods.

13.4 All damages that are not demonstrably the result of bad material, defective design, or deficient manufacture of the deliveries or services are excluded from warranty and liability, for example, those due to natural wear, deficient maintenance, failure to follow operating specifications, overloading, unsuitable tools, chemical or electrolytic influences, building or installation work not performed by the supplier, or for other reasons that are not the responsibility of the supplier.

13.5 For deliveries and services from any sub-suppliers that were prescribed by the buyer, the supplier assumes the warranty only under of the warranty obligations of the particular sub-supplier.

13.6 The buyer has no rights or claims due to defects in materials, design, or manufacture, or the absence or shortfall of guaranteed properties, or any other guarantees, other than those expressly listed in items 13.1 through 13.5.

13.7 For claims by the buyer due to deficient advice and the like, or due to infringement of any other secondary obligations, the supplier is liable only in case of illegal intent or gross negligence.

14. Exclusion of Further Liability of the Supplier

All cases of breach of contract and their legal consequences, as well as all claims by the buyer, regardless of their legal basis, are completely regulated by these conditions. In particular, all claims of repayment of damages, restitution, cancellation of the contract, or withdrawal from the contract are barred unless expressly named.

In no case do claims exist by the buyer for repayment of damages that did not occur on the delivered item itself, such as loss of production, loss of utility, loss of orders, foregone profits, or other direct or indirect damages. This exclusion of liability does not apply in case of illegal intent or gross negligence by the supplier, unless these are on the part of his agents. Also, this exclusion of liability is not valid if prohibited by law.

15. Installation

If the supplier also performs installation, installation supervision, or commissioning, then its General Installation Conditions apply.

16. Jurisdiction and Applicable Law

16.1 Jurisdiction for the buyer and the supplier is Baden. The supplier is, however, entitled to prosecute the buyer at its corporate location.

16.2 The legal relationship is subject to Swiss material law.

America

578

Asia, Far, Middle East & Oceania

578

Europe

579



America



LinMot USA

LinMot, Inc.
 N5750 Townline Road
 Elkhorn, WI 53121
 Sales 877-546-3270
 262-743-2555
 Tech. Service: 877-804-0718
 262-743-1284
 Fax: 800-463-8708
 262-723-6688
 E-Mail: sales@linmot-usa.com
 Web: www.linmot-usa.com



LinMot services North America through more than 60 distributor offices in the United States.

Please contact our US Sales Office for the name of your nearest distributor.

Canada

ONTARIO

Group Rotalec Inc.
 177 Blossom Avenue East, Unit A
 Brantford, Ontario N3T 5L9
 Tel.: (519) 753-5100
 Fax: (519) 753-5610
 E-Mail: ontario@rotalec.com
 Web: www.rotalec.com

QUEBEC

Group Rotalec Inc.
 900 rue McCaffrey
 Saint-Laurent, Quebec H4T 2C7
 Tel.: (514) 341-3685
 Fax: (514) 341-5205
 E-Mail: marketing@rotalec.com
 Web: www.rotalec.com

NEW BRUNSWICK

Group Rotalec Inc.
 122 Driscoll Crescent
 Moncton, New Brunswick E1E 3R8
 Tel.: (506) 858-9884
 Fax: (506) 853-4185
 E-Mail: atlantic@rotalec.com
 Web: www.rotalec.com

South America

BRASIL

Automation Ind. Com. Imp. Exp. Ltda.
 Acesso José Sartorelli, km 2.1
 18550 - 000 Boituva/SP
 Tel.: +55 (15) 3363 * 9900
 Fax: +55 (15) 3363 * 9911
 E-Mail: coml@automation.com.br
 Web: www.automation.com.br

Asia, Far, Middle East & Oceania

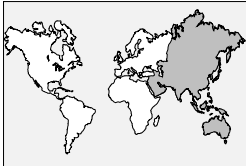

IRAN

FaraSys Engineering Ltd.
 APT#6, 3rd Flr, No. 15, 3 rd Kowsar St
 Sattarkhan Ave. Tehran
 Tel.: +98-21-6659 3517
 Fax: +98-21-6659 3520
 E-Mail: info@farasysco.com
 Web: www.farasysco.com

SYRIA

Etta Systems
 P.O. Box: 12850, Al-Hamra Str., Shalan, Bldg. #10-3 floor
 Syria - Damascus
 Tel.: +963-11-3325519
 Fax: +963-11-3342639
 E-Mail: info@ettasystems.com
 Web: www.ettasystems.com

AUSTRALIA

Motion Technologies Pty Ltd
 24/22-30 Northumberland Road
 Caringbah NSW 2229 Australia
 Tel.: +612 9524 4782
 Fax: +612 9525 3878
 E-Mail: info@motiointech.com.au
 Web: www.motiointech.com.au

MALAYSIA

Servo Dynamics Sdn. Bhd.
 17, Solok Kekabu 1, Permatang Damar Laut
 11960, Bayan Lepas, Penang, Malaysia
 Tel.: +604/6266388
 Fax: +604/6266088
 E-Mail: sales@servo.com.my
 Web: www.servo.com.my

TAIWAN

Montrrol Systems Co., Ltd.
 6F-4, No 56, Tongde 11th St.,
 Taoyuan City, Taiwan
 Tel.: +886-3-35 86 008
 Fax: +886-3-35 86 009
 E-Mail: info@montrrol.com.tw
 Web: www.montrrol.com.tw

CHINA

Gateway Motion (Shanghai) Co., Ltd
 901, Yongye Office Building, 2240 Pudong Rd. (S)
 200127 Shanghai, P.R. China
 Tel.: +86-21-5881 1015
 Fax: +86-21-5881 2505
 E-Mail: servo@gtmot.com
 Web: www.gtmot.com

NEW ZEALAND

John Brooks Ltd
 214 Waltham Rd
 Waltham
 Tel.: +64 3 366 9514
 Fax: +64 3 379 4876
 E-Mail: saleschc@johnbrooks.co.nz
 Web: www.johnbrooks.co.nz

THAILAND

SERVO DYNAMICS (THAILAND) CO., LTD
 50/37 - 38 M.9, SOI WAD-NAMDANG SRINAKARIN RD.,
 BANGKAEW BANGPLEE, SAMUTPRAKARN
 10540 THAILAND
 Tel.: +662-753 5625
 Fax: +662-753 5650
 E-Mail: info@servoline.com
 Web: www.servoline.com

HONG KONG

Servo Dynamics Co., Ltd.
 Room 1807, 18 Floor, Mega Trade Center 1 Mei Wan Street,
 Tsuen Wan, NT
 Hong Kong
 Tel.: +852-2409 9986
 Fax: +852-2409 7872
 E-Mail: sales@servodynamics.com.hk

SINGAPORE

Servo Dynamics Servo Dynamics Pte. Ltd.
 # 01-30 Kaki Bukit Industrial Park No. 10 Kaki Bukit Road 1
 SIN - 416175 Singapore
 Tel.: +65 / 8 / 44 02 88
 Fax: +65 / 8 / 44 00 70
 E-Mail: servodynamics@servo.com.sg
 Web: www.servo.com.sg

INDIA

Intelligent Motion Technology PVT. LTD.
 SR.NO.100 / 5 Ambegaon Road, Pune 411 046
 Maharashtra
 Tel.: +91 20 3939 2200
 Fax: +91 20 3939 2124
 E-Mail: info@intelmotion.com
 Web: www.intelmotion.com

SOUTH KOREA

JungWoo F&B Corp.
 #118, Nae-dong, Ojeong-gu, Bucheon-city
 Gyeonggi-do, Republic of Korea, 421-805
 Tel.: +82-32-683-6200
 Fax: +82-32-684-1010
 E-Mail: biz@jwfnb.co.kr
 Web: www.jwfnb.co.kr

Europe

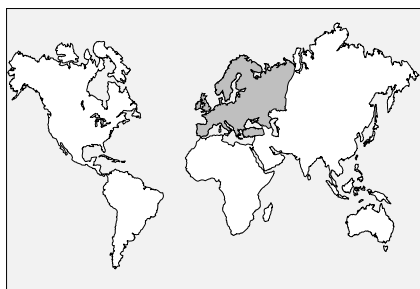

LinMot Europe

NTI AG
Haerdlistrasse 15
CH - 8957 Spreitenbach
Tel.: +41-(0)56-419 91 91
Fax: +41-(0)56-419 91 92
E-Mail: office@linmot.com
Web: www.linmot.com

AUSTRIA
Kwapil & Co.
Kammelmweg 9
A - 1210 Wien
Tel.: +43-1-278 85 85
Fax: +43-1-278 85 86
E-Mail: verkauf@kwapil.com
Web: www.kwapil.com

BELGIUM
Profilex S.A.
4A, Z.I. In den Allern
L - 9911 Troisvierges
Tel.: +352-998 906
Fax: +352-269 573 73
E-Mail: profiflex@pt.lu
Web: www.profilex-systems.com

CZECH REPUBLIC
Kwapil & Co.
Kammelmweg 9
A - 1210 Wien
Tel.: +43-1-278 85 85
Fax: +43-1-278 85 86
E-Mail: verkauf@kwapil.com
Web: www.kwapil.com

DENMARK
DELTA Elektronik A/S
Husby Allée 17
DK - 2630 Taastrup
Tel.: +45-4371 8088
Fax: +45-4371 8038
E-Mail: salg@deltaelektronik.dk
Web: www.deltaelektronik.dk

ENGLAND
Quin System Ltd., Oakland Business Center
Oakland Park, Wokingham
GB - Berkshire RG41 2FD
Tel.: +44-118 977 10 77
Fax: +44-118 977 67 28
E-Mail: sales@quin.co.uk
Web: www.quin.co.uk

FINLAND
SKS Control Oy
Martinkyläntie 50,
FIN - 01721 Vantaa
Tel.: +358-20-764 61
Fax: +358-20-764 6823
E-Mail: control@sks.fi
Web: www.sks.fi

FRANCE
transtechnik sa
17, rue des Grandes Varennes
F - 21121 Ahuy
Tel.: +33-3-8055 0000
Fax: +33-3-8053 9363
E-Mail: infos@transtechnik.fr
Web: www.transtechnik.fr

GERMANY
Please contact NTI AG, Switzerland
NTI AG
Haerdlistrasse 15
CH - 8957 Spreitenbach
Tel.: +41-(0)56-419 91 91
Fax: +41-(0)56-419 91 92
E-Mail: office@linmot.com
Web: www.linmot.com

GREECE
KALAMARAKIS-SAPOUNAS S.A.
Ionias & Neromilou Str.
GR - 13671 Acharnes, ATHENS
Tel.: +30-10-240 6000
Fax: +30-10-240 6007
E-Mail: kalamarakis.sappounas@ksa.gr
Web: www.ksa.gr

HOLLAND
Groneman BV
Amarilstraat11
NL - 7554 TV Hengelo
Tel.: +31-74-255 1155
Fax: +31-74-255 1109
E-Mail: info@groneman.nl
Web: www.groneman.nl

HUNGARY
Q-TECH Engineering Ltd & Co
Bathhány u. 8.
H-1161 Budapest
Tel.: +36-1-405 3338
Fax: +36-1-405 9134
E-Mail: info@q-tech.hu
Web: www.q-tech.hu

ISRAEL
Abiry Technologies Ltd.
P.O. Box 53051 31 Habarzel st
IL - 69710 Tel-Aviv
Tel.: +972-3-647 0471
Fax: +972-3-647 0472
E-Mail: abiry@abiry.com
Web: www.abiry.com

ITALY
Pamoco S.p.A.
Via R. Lombardi, 19/6
I - 20153 Milano
Tel.: +39-02-345 6091
Fax: +39-02-3310 4342
E-Mail: info@pamoco.it
Web: www.pamoco.it

LUXEMBOURG
Profilex S.A.
4A, Z.I. In den Allern
L - 9911 Troisvierges
Tel.: +352-998 906
Fax: +352-269 573 73
E-Mail: profiflex@pt.lu
Web: www.profilex-systems.com

NORWAY
Motion Control Senteret AS
P.O.Box 14, Haugerud
NO -0616 Oslo
Tel.: +47 900 300 49
E-Mail: salg@motioncontrol.no
Web: www.motioncontrol.no

SLOVENIA
Kwapil & Co.
Kammelmweg 9
A - 1210 Wien
Tel.: +43-1-278 85 85
Fax: +43-1-278 85 86
E-Mail: verkauf@kwapil.com
Web: www.kwapil.com

SPAIN
LARRAIOZ ELECTRÓNICA INDUSTRIAL S.A.
Larraioz Etxea Garate Mendi PK 193
E - 20800 Getaria (GIPUZKOA)
Tel.: +34 943 140 139
Fax: +34 943 140 327
E-Mail: motion@larraioz.com
Web: www.larraioz.com

SWEDEN
SDT AB, Skandinavian Drive Technologies
AB Sabelgatan 4
SE - 25467 Helsingborg
Tel.: +46-42-380 800
Fax: +46-42-380 813
E-Mail: info@sdt.se
Web: www.sdt.se

SWITZERLAND
NTI AG
Haerdlistrasse 15
CH - 8957 Spreitenbach
Tel.: +41-(0)56-419 91 91
Fax: +41-(0)56-419 91 92
E-Mail: office@linmot.com
Web: www.linmot.com

TURKEY
YORUM OTOMASYON AS.
Inönü cad. Samli apt. No:87 Kat:1 D.4
81090 Kozyatagi / Istanbul / Turkey
Tel.: +90-216-361 4430
Fax: +90-216-361 3994
E-Mail: yorum@yorumautomation.com
Web: www.yorumautomation.com

