

# MC4N-Mini EtherCAT Master

**NEW**

The MC4N is a new concept in high performance *Motion Coordinators* which is dedicated to running remote servo and stepper drives via the EtherCAT real time automation bus. It is based on an up-rated version of the 432MHz ARM 11 processor which makes it ideal for high axis count machines or robotic applications.

The MC4N supports up to 32 axes of motion with 64 bit integer position registers for ultra precise axis resolution. EtherCAT slave drives and I/O can be connected and run in cyclic synchronous position, speed or torque modes provided these are supported by the drive. Programming the MC4N is identical to using traditional analogue axes with the addition of being able to set up drives and process alarms over the EtherCAT bus. With everything programmed from one place, machine control has never been so simple.

**EtherCAT**

## FEATURES

- \* Up to 32 EtherCAT Digital Drive Axes
- \* Up to 1024 EtherCAT I/O
- \* EtherCAT CoE protocol to CiA402
- \* Linear, Circular, Helical and Spherical Interpolation
- \* Flexible CAM shapes, Linked Motion
- \* Isolated Encoder Port
- \* EnDAT and SSI Absolute Encoder Supported
- \* Hardware Linked Output for Camera / Laser Control
- \* Ethernet-IP / Modbus TCP / Trio ActiveX / Uniplay HMI / UDP / Ethernet Interface Built-In
- \* Precise 64Bit Motion Calculations with 466MHz ARM 11 Processor
- \* IEC 61131-3 Programming
- \* Multi-tasking BASIC Programming
- \* Text File Handling
- \* Robotic Transformations
- \* 4 High Speed Registration Inputs
- \* Isolated RS232 and RS485 ports
- \* SD Memory Card Slot
- \* EtherCAT I/O Expansion
- \* CANopen I/O Expansion
- \* Backlit LCD Display
- \* RoHS and CE Approved

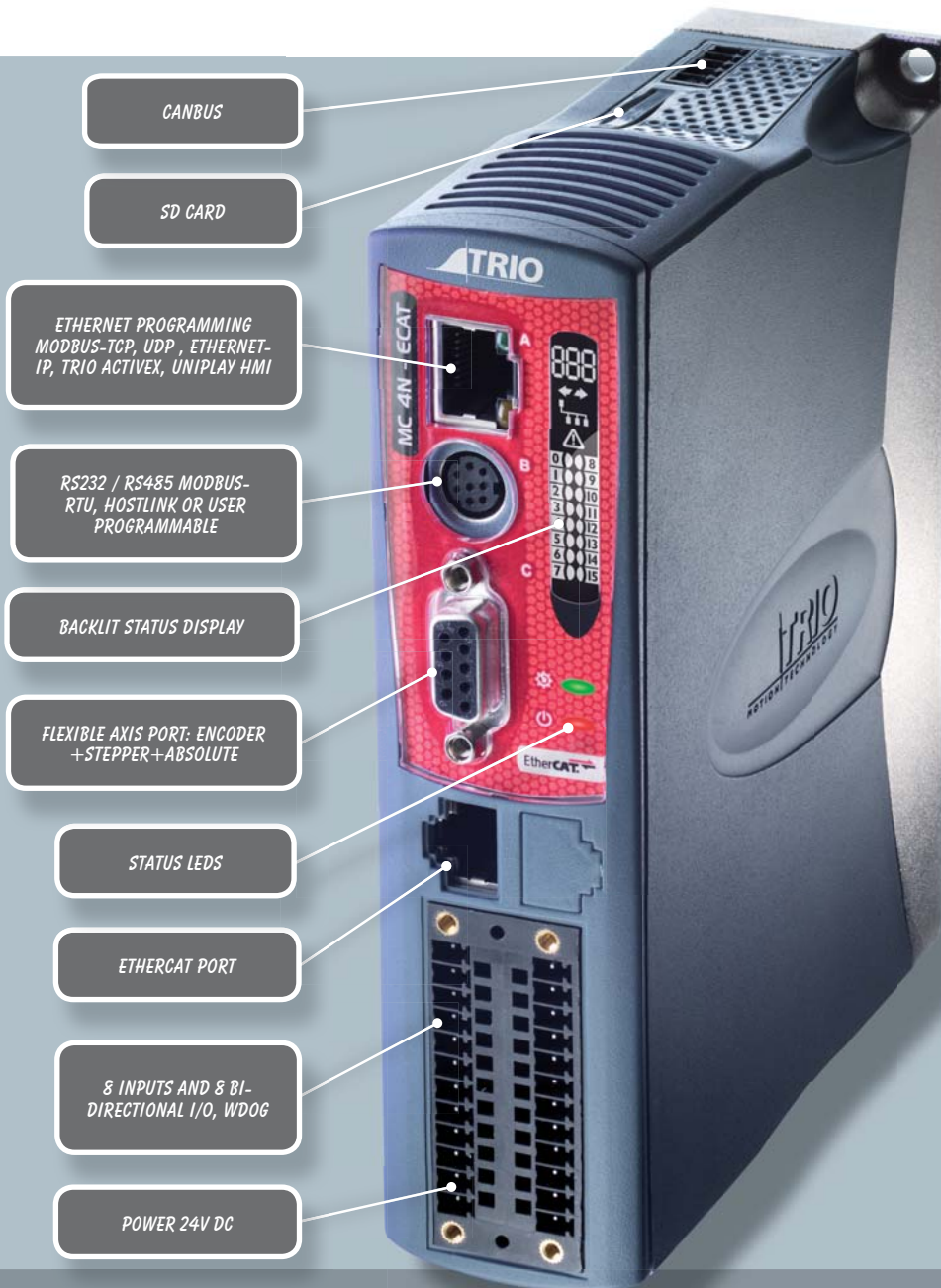

The built-in Ethernet port allows programming and connection of common PLC and HMI protocols, including the Trio Uniplay range of HMIs, directly to the MC4N. User programs can be written in Trio's established multi-tasking TrioBASIC language using the powerful *Motion Perfect v3* application development software making complex motion easy. The industry standard IEC 61131-3 languages are available as an option, allowing a fully functional PLC programming system.

Versions of the MC4N are available for 2, 4, 8, 16 and 32 motor axes. All versions feature 32 software axes any of which may be used as virtual axes if not assigned to EtherCAT hardware. Every axis can be programmed to move using linear, circular or helical or spherical interpolation, electronic cams, linked axes and gearboxes. The power of the controller allows for multiple robotic transformations to run simultaneously.

A bright easy to read backlit display enables the controller status to be easily determined, whilst the single piece metal cast backplate provides an integrated earth chassis to improve noise rejection in the industrial environment.

#### OVERALL DIMENSIONS:

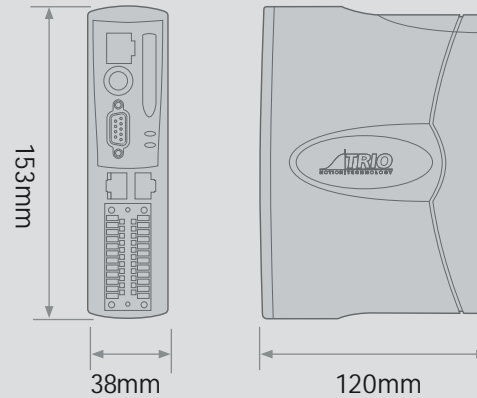

#### ACCESSORIES:

P317 - P327	CAN Modules
P750	Kinematic Runtime FEC
P843 - P844	UNIPLAY 7" & 10" HMI's

#### PRODUCT CODES:

P900	2 Axis
P901	4 Axis
P902	8 Axis
P903	16 Axis
P904	32 Axis

Built-in support for digital drives from:

ABB  
Baumueller  
Beckhoff  
Control Techniques  
Delta  
Dunkermotoren  
Elmo  
Estun  
Infranor  
Jenny Science  
KEB  
Kuebler  
Kollmorgen  
Lenze  
LinMot  
LTi Drives  
LS Mecapion  
Maxon Motor  
MCS Inc  
Mitsubishi  
MKS Intruments  
Moog  
Nanotec Electronics  
Omron  
Panasonic  
Sanyo Denki  
Schneider Electric  
Sick  
TR-Electronic  
Yaskawa

And many more...

Built-in support for I/O from:

ACS Motion  
Bachmann  
Beckhoff  
Deutsmann  
Eltromat  
Festo  
Grossenbacher  
Hilscher  
Imficon  
Kuhnke  
Lenze  
MURR Elektronik  
Omron  
Panasonic  
SMC  
VIPA  
Wenglor Sensor  
WAGO

And many more...

FACTORY ETHERNET  
COMMS eg: ETHERNET I/P

