

# FT Series Linear Actuators

Exlar FT Series force tube actuators use a planetary roller screw mounted inside a telescoping tube mechanism. The follower is attached to the moveable force tube, which then extends and retracts as the screw

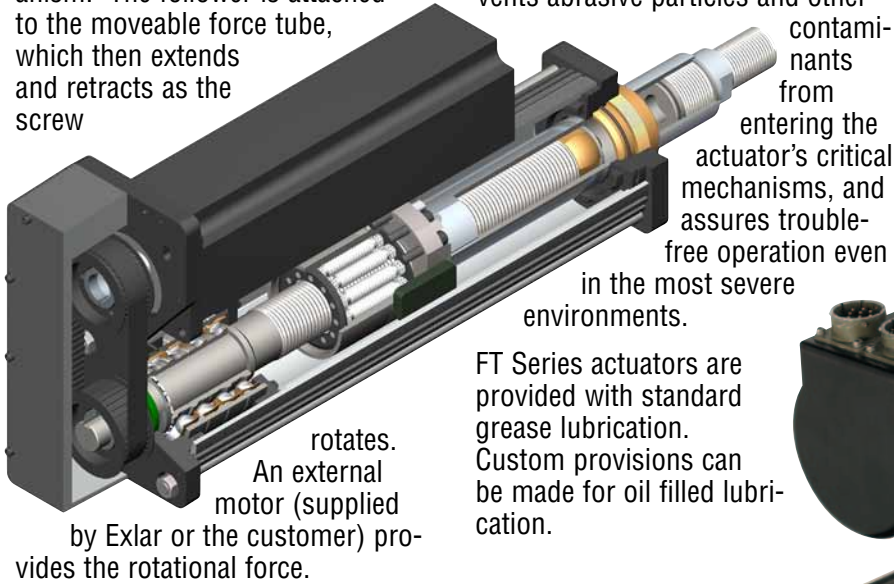

FT Series actuators are provided with standard grease lubrication. Custom provisions can be made for oil filled lubrication.

## Engineered Compatibility

Exlar has removed much of the end-user-engineering burden by designing the FT series to be compatible with a wide variety of standard motors. Motor mounting, actuator mounting, and gearing configurations are available to meet nearly any application's requirements.

## High Performance

As with all of Exlar's roller screw products, the FT Series actuators deliver heavy load capacity, high speed capabilities, and exceptionally long life when compared to other linear actuator technologies.

Other comparably-sized screw actuator products on the market - specifically ball screw and acme screw actuators - have relatively low load capacities, short working lives and limited speed capabilities. At equivalent sizes, under moderate to heavy loads, it is reasonable to project that FT units will deliver up to 15 times the working life of those other designs. For OEM designers, this often means much more power and durability can be achieved from a much smaller footprint when Exlar FT units are used.

## Contamination Protection

The FT Series design has all the

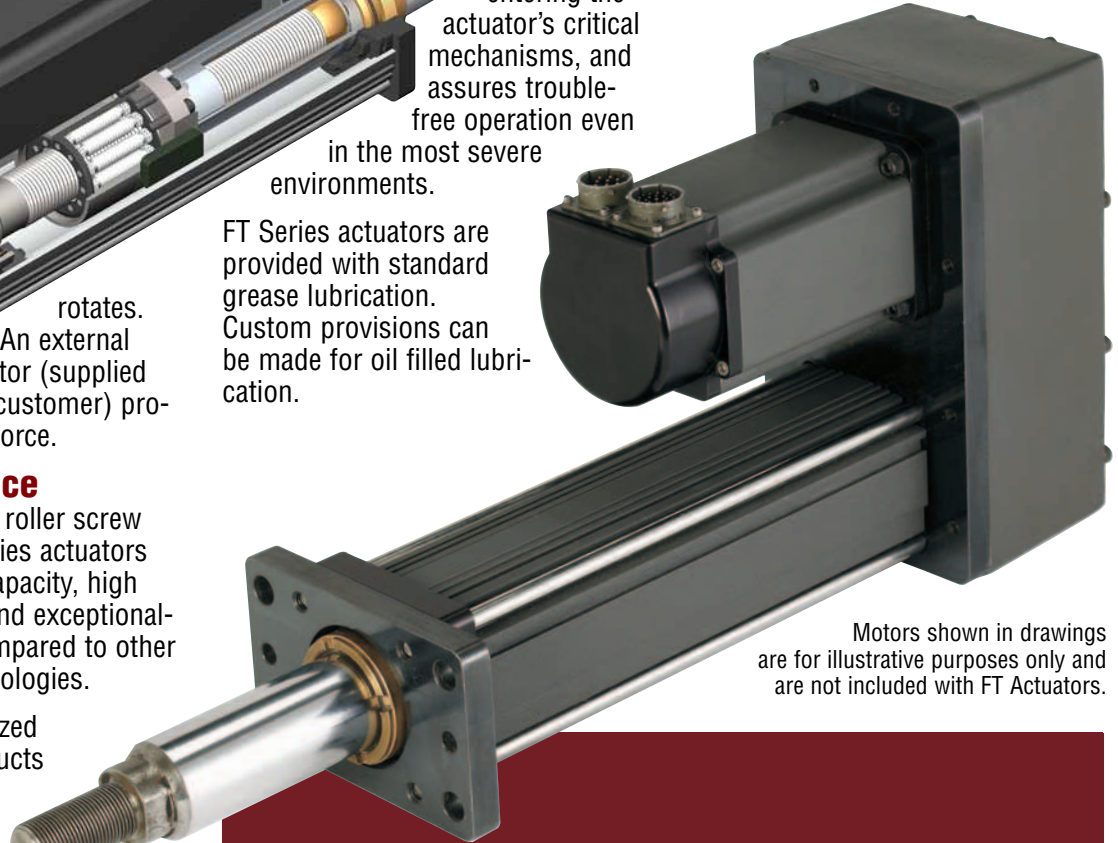

Feature	Standard	Optional
Long Strokes	12 inches to 8 feet	Intermediate & Custom Stroke Lengths
Pre-Loaded Follower	No	Yes
External End Switches	No	One, two or three Adjustable Switches
Multiple Actuator Mountings	Side Mount, Side Lug, Extended Tie Rods, Rear Clevis, Front Flange, Side Trunnion, Rear Flange, Front/Rear Flange	OEM Specials Available
Multiple Motor Mounting Configurations	Inline Direct Drive, Parallel 1:1 Drive, Parallel, 2:1 Reduction	OEM Specials Available

## Special Sealing Options

The base unit of the FT actuators are sealed at the extending rod end by a rod seal, and on the drive end by a shaft seal (see base unit drawing on page 71). These rod and shaft seals, and o-ring sealing provides IP65 sealing for the FT actuator base units.

In standard units with inline, or parallel motor mounting, the mounting surface between the actuator and the motor, and between the end cover, or inline cover of the actuator and the actuator housing are not sealed as a standard feature.

These areas of the FT actuators can be sealed as a special option if

*Stainless steel FT35 with stainless steel SLM115 motor*

*Food grade & stainless steel FT35 with food grade SLM90 motor*

*Food grade & stainless steel FT60 with food grade SLG90 motor*

the environment in which the actuator will be mounted requires the actuator to be sealed. Because of the vast differences in the design of various brands of motors that are mounted to the FT Series actuators, sealing of these two areas

may alter the design of the actuator. Consult Exlar applications engineering for details and quotations on special sealing of this type.

## EXLAR FT SERIES ACTUATORS APPLICATIONS INCLUDE:

Hydraulic cylinder replacement  
Ball screw replacement  
Pneumatic cylinder replacement  
Chip and wafer handling  
Automated flexible fixturing  
Dispensers  
Machine tool  
Automated assembly  
Parts clamping  
Automatic tool changers  
Volumetric pumps  
Medical equipment

Conveyor diverters / gates  
Plastics equipment  
Cut-offs  
Die cutters  
Packaging machinery  
Entertainment  
Sawmill equipment  
Open / close doors  
Fillers  
Formers  
Precision grinders  
Indexing stages

Lifts  
Product sorting  
Material cutting  
Material handling  
Riveting / fastening / joining  
Molding  
Volumetric pumps  
Semiconductor  
Pick and place systems  
Robot manipulator arms  
Simulators  
Precision valve control

Ventilation control systems  
Pressing  
Process control  
Tube bending  
Welding  
Stamping  
Test stands  
Tension control  
Web guidance  
Wire winding

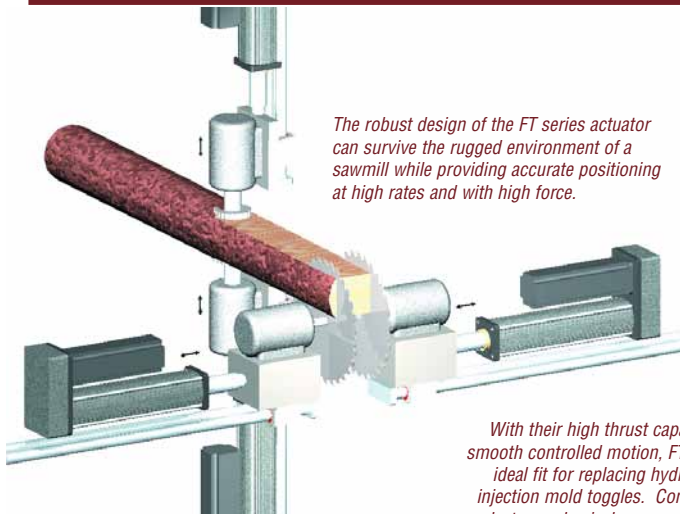

*The robust design of the FT series actuator can survive the rugged environment of a sawmill while providing accurate positioning at high rates and with high force.*

*The smooth and accurate motion of Exlar's actuators combined with today's servo technology make multiple degree of freedom motion simulation applications easier to implement, cleaner and more efficient than hydraulic solutions.*

*With their high thrust capability, compact size and smooth controlled motion, FT Series actuators are an ideal fit for replacing hydraulics or pneumatics on injection mold toggles. Control improvements from an electromechanical servo system offer less abuse of valuable molds and more consistent performance.*

Motors shown in drawings are for illustrative purposes only and are not included with FT Actuators.

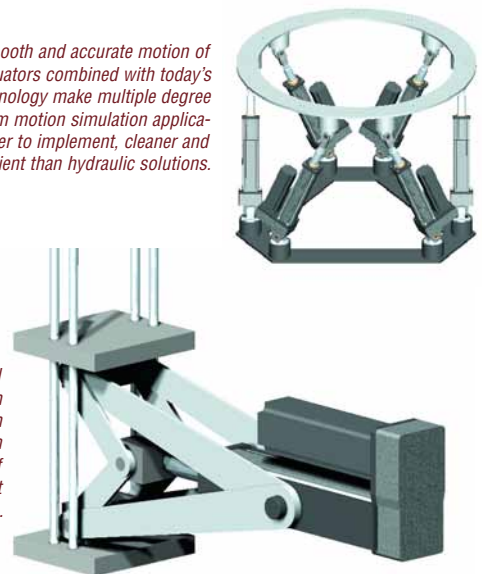

# FT Series Lifetime Curves

The expected life of a force tube actuator is expressed as the travel distance that 90% of the actuators are expected to exceed before experiencing metal fatigue. The formula that defines this value is:

The underlying formula that defines this value is:

$$L_{10} = (C/F)^3 \times S \quad \text{where} \quad \begin{aligned} C &= \text{Dynamic load rating (lbs)} \\ F &= \text{Cubic mean applied load (lbs.)} \\ S &= \text{Roller screws lead (inches)} \end{aligned}$$

Travel life in millions of inches, where:

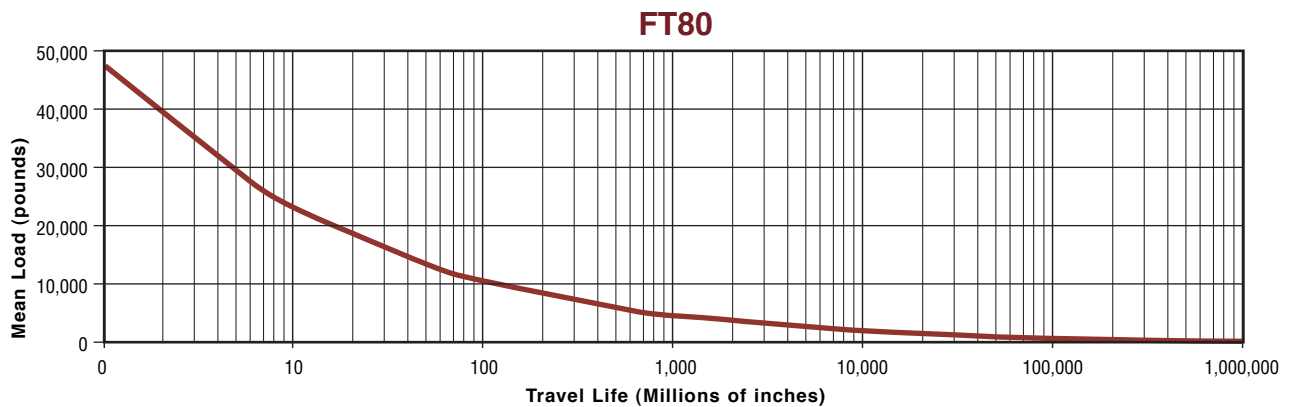
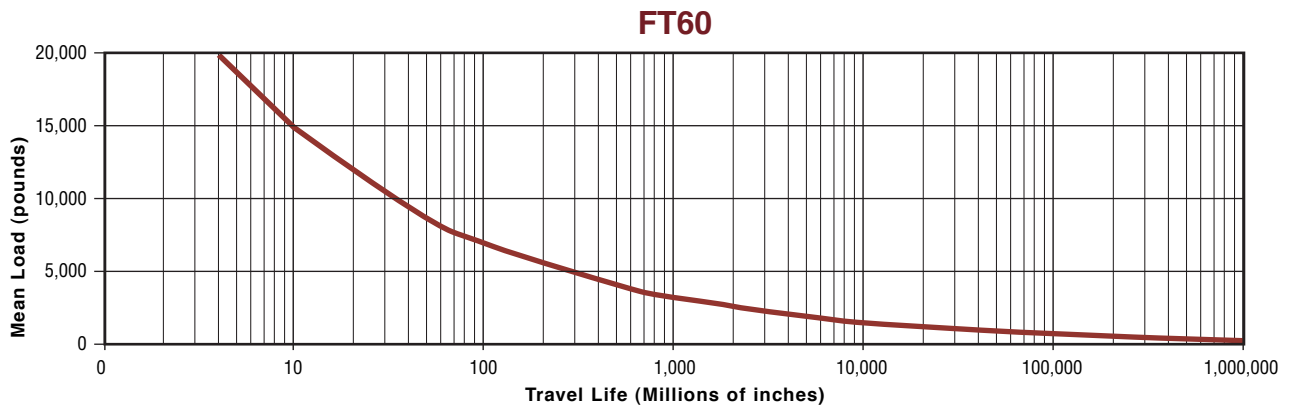
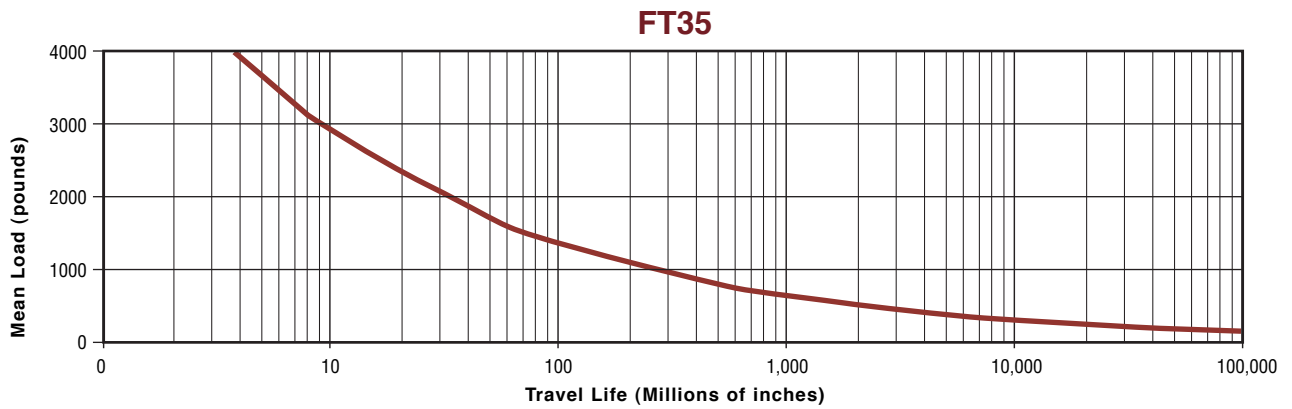

# FT Series Performance Specifications

Model No.	Frame Size in (mm)	Stroke in (mm)	Screw Lead in (mm)	Max. Linear Speed in/sec (mm/sec)	Dynamic Load Rating (std. follower) lbf (kN)	Torque @ Rated Force lb-in (N-m)	Screw Inertia lb-in-s <sup>2</sup> (kg-m <sup>2</sup> )	Max. Force* lbf (kN)	Max. Rot. Speed rpm	Weight Base Unit lb (kg)
FT35-0605	3.5 (89)	6 (152)	0.2 (5)	14.7 (373)	10700 (47.5)	150 (16.5)	0.0019 (0.00022)	4000 (17.8)	4500	30 (14)
FT35-0610	3.5 (89)	6 (152)	0.39 (10)	29.5 (750)	8700 (38.5)	300 (33.9)	0.0019 (0.00022)	4000 (17.8)	4500	30 (14)
FT35-0620	3.5 (89)	6 (152)	0.79 (20)	59.3 (1500)	7100 (31.5)	600 (67.8)	0.0019 (0.00022)	4000 (17.8)	4500	30 (14)
FT35-1205	3.5 (89)	12 (304)	0.2 (5)	14.7 (373)	10700 (47.5)	150 (16.5)	0.0027 (0.00031)	4000 (17.8)	4500	35 (16)
FT35-1210	3.5 (89)	12 (304)	0.39 (10)	29.5 (750)	8700 (38.5)	300 (33.9)	0.0027 (0.00031)	4000 (17.8)	4500	35 (16)
FT35-1220	3.5 (89)	12 (304)	0.79 (20)	59.3 (1500)	7100 (31.5)	600 (67.8)	0.0027 (0.00031)	4000 (17.8)	4500	35 (16)
FT35-1805	3.5 (89)	18 (457)	0.2 (5)	14.7 (373)	10700 (47.5)	150 (16.5)	0.0037 (0.00042)	4000 (17.8)	4500	40 (18)
FT35-1810	3.5 (89)	18 (457)	0.39 (10)	29.5 (750)	8700 (38.5)	300 (33.9)	0.0037 (0.00042)	4000 (17.8)	4500	40 (18)
FT35-1820	3.5 (89)	18 (457)	0.79 (20)	59.3 (1500)	7100 (31.5)	600 (67.8)	0.0037 (0.00042)	4000 (17.8)	4500	40 (18)
FT35-2405	3.5 (89)	24 (610)	0.2 (5)	14.7 (373)	10700 (47.5)	150 (16.5)	0.0045 (0.00051)	4000 (17.8)	4500	45 (21)
FT35-2410	3.5 (89)	24 (610)	0.39 (10)	29.5 (750)	8700 (38.5)	300 (33.9)	0.0045 (0.00051)	4000 (17.8)	4500	45 (21)
FT35-2420	3.5 (89)	24 (610)	0.79 (20)	59.3 (1500)	7100 (31.5)	600 (67.8)	0.0045 (0.00051)	4000 (17.8)	4500	45 (21)
FT35-3605	3.5 (89)	36 (914)	0.2 (5)	8.9 (226)	10700 (47.5)	150 (16.5)	0.0061 (0.00069)	4000 (17.8)	2700	55 (25)
FT35-3610	3.5 (89)	36 (914)	0.39 (10)	17.8 (452)	8700 (38.5)	300 (33.9)	0.0061 (0.00069)	4000 (17.8)	2700	55 (25)
FT35-3620	3.5 (89)	36 (914)	0.79 (20)	35.6 (903)	7100 (31.5)	600 (67.8)	0.0061 (0.00069)	4000 (17.8)	2700	55 (25)
FT35-4805	3.5 (89)	48 (1219)	0.2 (5)	5.7 (145)	10700 (47.5)	150 (16.5)	0.0076 (0.00086)	4000 (17.8)	1700	65 (30)
FT35-4810	3.5 (89)	48 (1219)	0.39 (10)	11.4 (290)	8700 (38.5)	300 (33.9)	0.0076 (0.00086)	4000 (17.8)	1700	65 (30)
FT35-4820	3.5 (89)	48 (1219)	0.79 (20)	22.4 (568)	7100 (31.5)	600 (67.8)	0.0076 (0.00086)	4000 (17.8)	1700	65 (30)

FT Series

Intermediate and custom stroke lengths are available. Intermediate leads may also be available. Belt and pulley inertia varies with ratio & motor selection. Contact Exlar's Applications Engineering Department for more information. See page 69 for definition of terms.

\* The rated and max force on the FT series actuators are those forces derived from using typical servo motors of similar frame size to the actuator, at their rated continuous and peak torques. In many cases FT actuators can be configured with input sufficient to exceed these forces. Contact Exlar for further details.

## FT Standard Inline Coupling Maximum Torque Ratings and Inertia

	Torque Rating	Inertia
FT35	40N-m (354 lbf-in)	0.30 lb-in, 0.000777 lbf-in-sec <sup>2</sup>

Pulley inertias lbf-in-sec<sup>2</sup>, reflected at motor including typical pulleys, belt and standard bushings. Because of differences in belt and pulley selection due to particular motor choices, please contact Exlar's Application Engineering Department if these values are critical to your application.

FT35 3 inch motor 1:1 = 0.004874 FT35 4 inch motor 1:1 = 0.009993  
 FT35 3 inch motor 2:1 = 0.002087 FT35 4 inch motor 2:1 = 0.005003

## FT Series Performance Specifications

Model No.	Frame Size in (mm)	Stroke in (mm)	Screw Lead in (mm)	Max. Linear Speed in/sec (mm/sec)	Dynamic Load Rating (std. follower) lbf (kN)	Torque @ Rated Force lb-in (N-m)	Screw Inertia lb-in-s <sup>2</sup> (kg-m <sup>2</sup> )	Max. Force* lbf (kN)	Max. Rot. Speed rpm	Weight Base Unit lb (kg)
<b>FT60-1206</b>	6.0 (152)	12 (305)	0.23 (6)	7.9 (201)	51900 (231)	920 (103.9)	0.0454 (0.0051)	20,000 (90.8)	2000	100 (45)
<b>FT60-1212</b>	6.0 (152)	12 (305)	0.47 (12)	15.8 (401)	44600 (199)	1720 (194.3)	0.0454 (0.0051)	20,000 (90.8)	2000	100 (45)
<b>FT60-1230</b>	6.0 (152)	12 (305)	1.18 (30)	39.0 (1000)	41700 (186)	4400 (497.1)	0.0454 (0.0051)	20,000 (90.8)	2000	100 (45)
<b>FT60-2406</b>	6.0 (152)	24 (610)	0.23 (6)	7.9 (201)	51900 (231)	920 (103.9)	0.073 (0.0083)	20,000 (90.8)	2000	130 (59)
<b>FT60-2412</b>	6.0 (152)	24 (610)	0.47 (12)	15.8 (401)	44600 (199)	1720 (194.3)	0.073 (0.0083)	20,000 (90.8)	2000	130 (59)
<b>FT60-2430</b>	6.0 (152)	24 (610)	1.18 (30)	39.0 (1000)	41700 (186)	4400 (497.1)	0.073 (0.0083)	20,000 (90.8)	2000	130 (59)
<b>FT60-3606</b>	6.0 (152)	36 (914)	0.23 (6)	7.9 (201)	51900 (231)	920 (103.9)	0.1 (0.0113)	20,000 (90.8)	2000	160 (72)
<b>FT60-3612</b>	6.0 (152)	36 (914)	0.47 (12)	15.8 (401)	44600 (199)	1720 (194.3)	0.1 (0.0113)	20,000 (90.8)	2000	160 (72)
<b>FT60-3630</b>	6.0 (152)	36 (914)	1.18 (30)	39.0 (1000)	41700 (186)	4400 (497.1)	0.1 (0.0113)	20,000 (90.8)	2000	160 (72)
<b>FT60-4806</b>	6.0 (152)	48 (1219)	0.23 (6)	7.9 (201)	51900 (231)	920 (103.9)	0.126 (0.0142)	20,000 (90.8)	2000	190 (86)
<b>FT60-4812</b>	6.0 (152)	48 (1219)	0.47 (12)	15.8 (401)	44600 (199)	1720 (194.3)	0.126 (0.0142)	20,000 (90.8)	2000	190 (86)
<b>FT60-4830</b>	6.0 (152)	48 (1219)	1.18 (30)	39.0 (1000)	41700 (186)	4400 (497.1)	0.126 (0.0142)	20,000 (90.8)	2000	190 (86)

Intermediate and custom stroke lengths are also available. Intermediate leads may also be available. Belt and pulley inertia varies with ratio and motor selection.

\* The rated and max force on the FT series actuators are those forces derived from using typical servo motors of similar frame size to the actuator, at their rated continuous and peak torques. In many cases FT actuators can be configured with input sufficient to exceed these forces. Contact Exlar for further details.

### Ft Standard Inline Coupling Maximum Torque Ratings and Inertia

	Torque Rating	Inertia
<b>FT60</b>	100N-m (885 lbf-in)	0.90 lb-in, 0.002331 lbf-in-sec <sup>2</sup>

Pulley inertias lbf-in-sec<sup>2</sup>, reflected at motor including typical pulleys, belt and standard bushings. Because of differences in belt and pulley selection due to particular motor choices, please contact Exlar's Application Engineering Department if these values are critical to your application.

FT60 1:1 = 0.030000

FT60 2:1 = 0.035000

### Definitions:

**Max Linear Speed:** The linear speed achieved by the actuator at a screw speed equal to the max rotational speed value.

**Rated Force:** The linear force produced by the actuator at the torque at the rated force value.

**Dynamic Load Rating:** A design constant used in calculating the estimated travel life of the roller screw. The dynamic mean load is the mean load at which the device will perform one million revolutions.

**Torque At Rated Force:** The torque required at the screw to produce the force rating.

**Screw Inertia:** The rotary inertia of the planetary roller screw in the actuator.

**Max. Rot. Speed:** The maximum allowable rotational screw speed determined by the screw length or the rotational speed limit of the roller screw nut.



# FT Series Performance Specifications

Model No.	Frame Size in (mm)	Stroke in (mm)	Screw Lead in (mm)	Max. Linear Speed in/sec (mm/sec)	Dynamic Load Rating (std. follower) lbf (kN)	Torque @ Rated Force lb-in (N-m)	Screw Inertia lb-in-s <sup>2</sup> (kg-m <sup>2</sup> )	Max. Force* lbf (kN)	Max. Rot. Speed rpm	Weight Base Unit lb (kg)
<b>FT80-1206</b>	8.0 (203)	12 (305)	0.23 (6)	6.9 (175)	80700 (358)	1950 (220.3)	0.1630 (0.0184)	40,000 (178)	1750	190 (86)
<b>FT80-1212</b>	8.0 (203)	12 (305)	0.47 (12)	13.8 (351)	70200 (312)	3550 (401.1)	0.1630 (0.0184)	40,000 (178)	1750	190 (86)
<b>FT80-1230</b>	8.0 (203)	12 (305)	1.18 (30)	34.4 (875)	64700 (288)	8840 (998.8)	0.1630 (0.0184)	40,000 (178)	1750	190 (86)
<b>FT80-2406</b>	8.0 (203)	24 (610)	0.23 (6)	6.9 (175)	80700 (358)	1950 (220.3)	0.247 (0.0279)	40,000 (178)	1750	265 (120)
<b>FT80-2412</b>	8.0 (203)	24 (610)	0.47 (12)	13.8 (351)	70200 (312)	3550 (401.1)	0.247 (0.0279)	40,000 (178)	1750	265 (120)
<b>FT80-2430</b>	8.0 (203)	24 (610)	1.18 (30)	34.4 (875)	64700 (288)	8840 (998.8)	0.247 (0.0279)	40,000 (178)	1750	265 (120)
<b>FT80-3606</b>	8.0 (203)	36 (914)	0.23 (6)	6.9 (175)	80700 (358)	1950 (220.3)	0.331 (0.0374)	40,000 (178)	1750	340 (153)
<b>FT80-3612</b>	8.0 (203)	36 (914)	0.47 (12)	13.8 (351)	70200 (312)	3550 (401.1)	0.331 (0.0374)	40,000 (178)	1750	340 (153)
<b>FT80-3630</b>	8.0 (203)	36 (914)	1.18 (30)	34.4 (875)	64700 (288)	8840 (998.8)	0.331 (0.0374)	40,000 (178)	1750	340 (153)
<b>FT80-4806</b>	8.0 (203)	48 (1219)	0.23 (6)	6.9 (175)	80700 (358)	1950 (220.3)	0.415 (0.0468)	40,000 (178)	1750	415 (187)
<b>FT80-4812</b>	8.0 (203)	48 (1219)	0.47 (12)	13.8 (351)	70200 (312)	3550 (401.1)	0.415 (0.0468)	40,000 (178)	1750	415 (187)
<b>FT80-4830</b>	8.0 (203)	48 (1219)	1.18 (30)	34.4 (875)	64700 (288)	8840 (998.8)	0.415 (0.0468)	40,000 (178)	1750	415 (187)

Intermediate and custom stroke lengths are also available. Intermediate leads may also be available. Belt and pulley inertia varies with ratio and motor selection. Please contact Exlar's Applications Engineering Department for more information. See page 69 for definitions of terms.

\* The rated and max force on the FT series actuators are those forces derived from using typical servo motors of similar frame size to the actuator, at their rated continuous and peak torques. In many cases FT actuators can be configured with input sufficient to exceed these forces. Contact Exlar for further details.

## FT Standard Inline Coupling Maximum Torque Ratings and Inertia

	Torque Rating	Inertia
<b>FT80</b>	200N-m (1770 lbf-in)	3.89 lb-in, 0.010075 lbf-in-sec <sup>2</sup>

Pulley inertias lbf-in-sec<sup>2</sup>, reflected at motor including typical pulleys, belt and standard bushings. Because of differences in belt and pulley selection due to particular motor choices, please contact Exlar's Application Engineering Department if these values are critical to your application.

FT80 1:1 = 0.235000

FT80 2:1 = 0.157000

## FT Series Mechanical Specifications

	FT35	FT60	FT80
Roller Screw Backlash in (mm)	0.0004 - 0.001 (0.01 - 0.03)	0.0004 - 0.001 (0.01 - 0.03)	0.0004 - 0.001 (0.01 - 0.03)
Preloaded Loader Screw Backlash	0	0	0
System Backlash:* in (mm)	0.002 (0.006)	0.002 (0.006)	0.002 (0.006)
Standard Lead Accuracy:** in/ft (mm/mm)	0.001 (.025/300)	0.001 (.025/300)	0.001 (.025/300)
Maximum Radial Load	0	0	0
Environmental Rating: (Base Unit Only)***	Standard IP65	Standard IP65	Standard IP65
Case:	Standard Optional	Epoxy-coated aluminum Food Grade Coating	Epoxy-coated aluminum Food Grade Coating

\* System backlash will be different with various types of motor mounting arrangements and couplings. Please discuss your particular configuration with Exlar application engineers.

\*\* Optional lead accuracy – from 0.0002 in/ft (6µm/300mm) to 0.002 in/ft (200µm/10000mm) – are also available.

\*\*\* For IP65 scaling of unit with motor mounted, please contact Exlar's Applications Engineering Department for more information and ordering information.

## FT35 Linear Actuator Base Unit

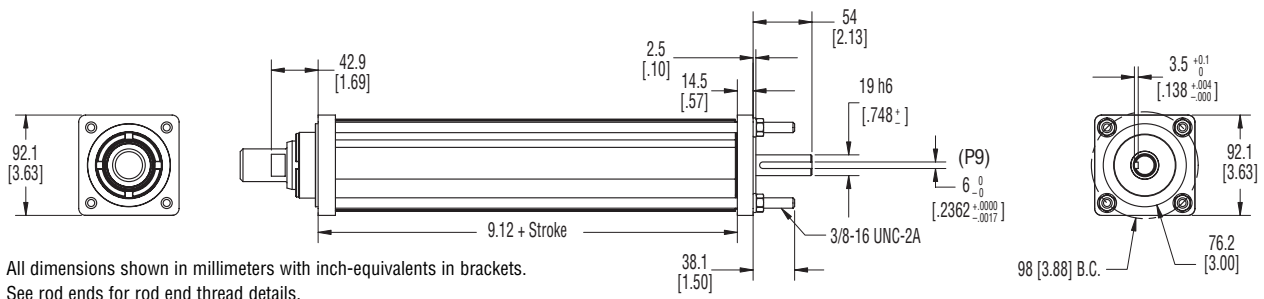

All dimensions shown in millimeters with inch-equivalents in brackets.  
See rod ends for rod end thread details.

## FT35 Linear Actuator Clevis Mount Unit

Parallel motor mount shown.

All dimensions shown in millimeters with inch-equivalents in brackets.

See rod ends for rod end thread details.

Motor plate and cover dimensions are subject to change depending on the motor selection.

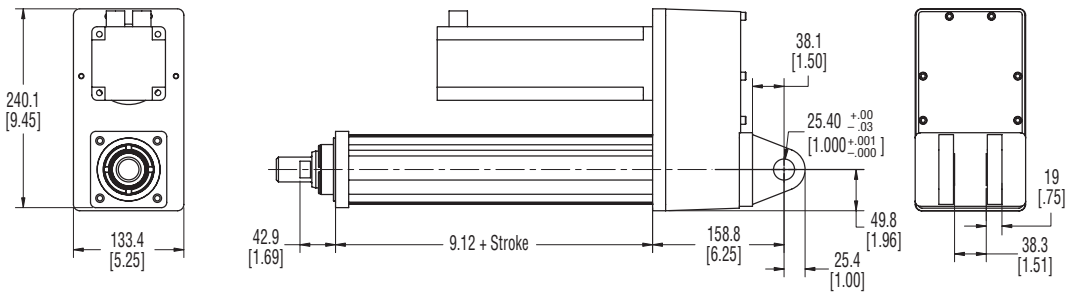

## FT35 Linear Actuator Front Flange Unit

Parallel motor mount shown.

All dimensions shown in millimeters with inch-equivalents in brackets.

See rod ends for rod end thread details.

Motor plate and cover dimensions are subject to change depending on the motor selection.

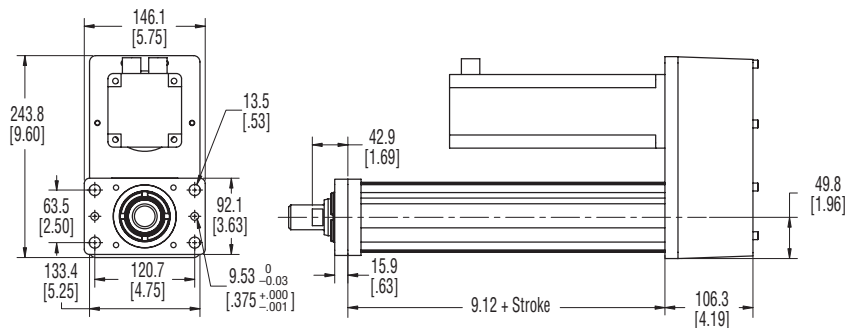

## FT35 Linear Actuator Rear Flange Unit

Parallel motor mount shown.

All dimensions shown in millimeters with inch-equivalents in brackets.

See rod ends for rod end thread details.

Motor plate and cover dimensions are subject to change depending on the motor selection.

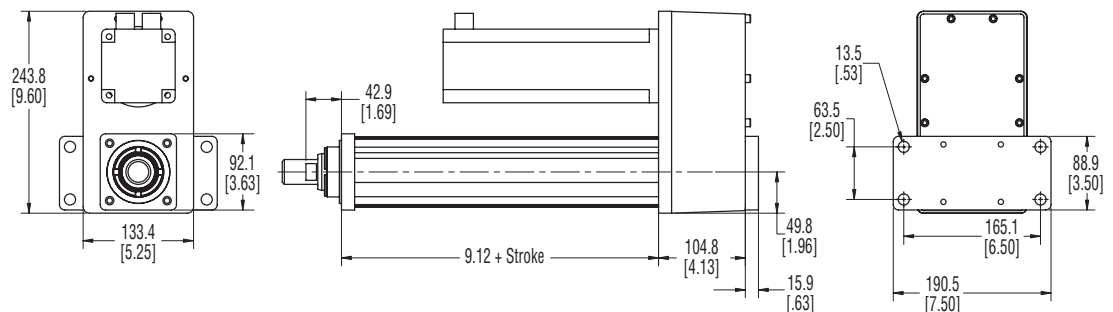

## FT35 Linear Actuator Trunnion Unit

Parallel motor mount shown.  
 All dimensions shown in millimeters with inch-equivalents in brackets.  
 See rod ends for rod end thread details.  
 Motor plate and cover dimensions are subject to change depending on the motor selection.

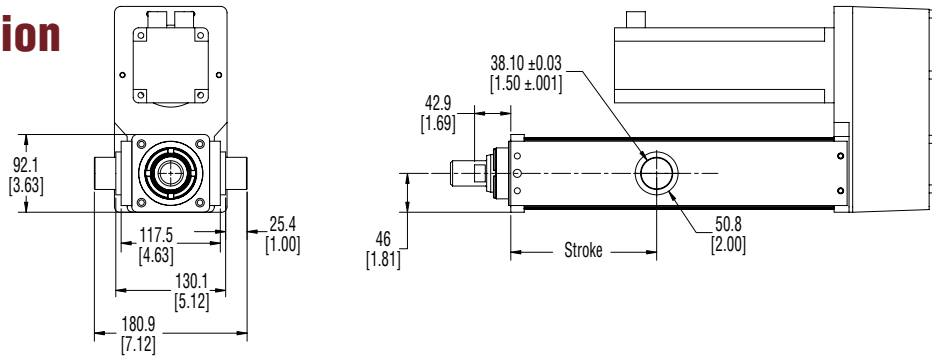

## FT35 Linear Actuator Extended Tie Rod Unit

Parallel motor mount shown.  
 All dimensions shown in millimeters with inch-equivalents in brackets.  
 See rod ends for rod end thread details.  
 Motor plate and cover dimensions are subject to change depending on the motor selection.

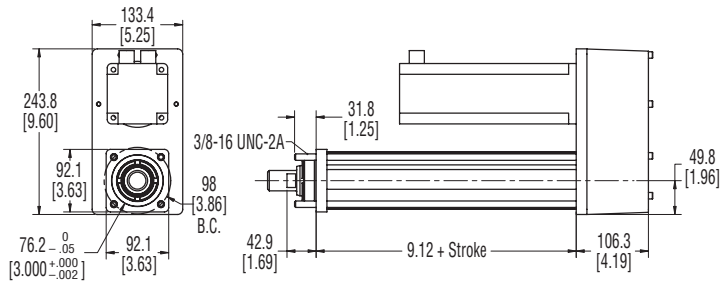

## FT35 Linear Actuator Side Lug Unit

Parallel motor mount shown.  
 All dimensions shown in millimeters with inch-equivalents in brackets.  
 See rod ends for rod end thread details.  
 Motor plate and cover dimensions are subject to change depending on the motor selection.

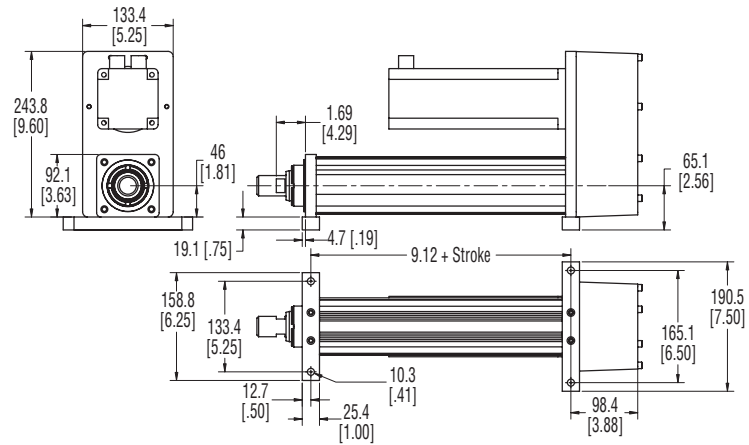

## FT35 Linear Actuator Side Mount Unit

Parallel motor mount shown.  
 All dimensions shown in millimeters with inch-equivalents in brackets.  
 See rod ends for rod end thread details.  
 Motor plate and cover dimensions are subject to change depending on the motor selection.

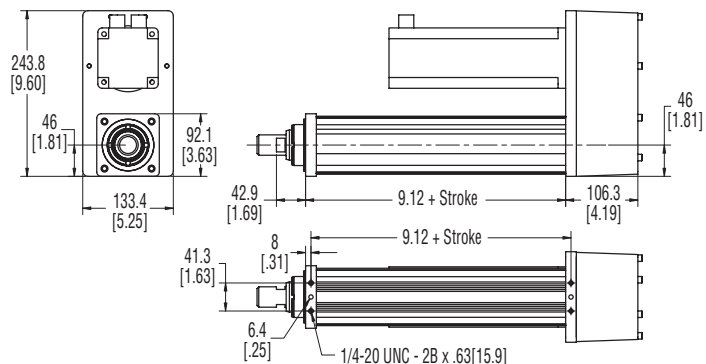



## FT60 Linear Actuator Base Unit

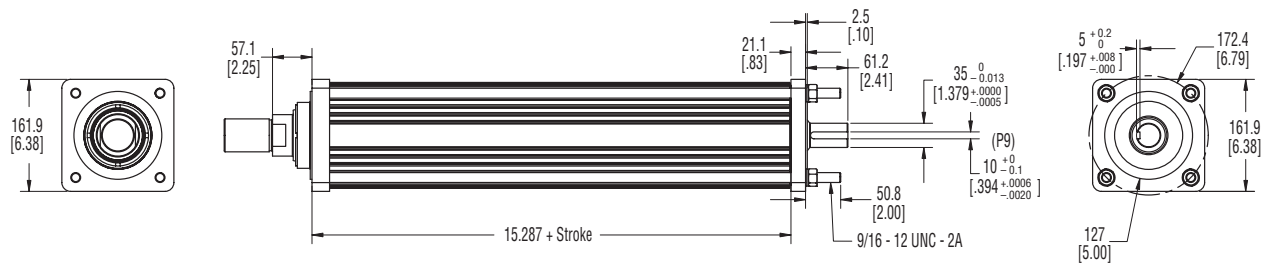

All dimensions shown in millimeters with inch-equivalents in brackets.  
See rod ends for rod end thread details.

## FT60 Linear Actuator Clevis Mount Unit

Parallel motor mount shown.

All dimensions shown in millimeters with inch-equivalents in brackets.

See rod ends for rod end thread details.

Motor plate and cover dimensions are subject to change depending on the motor selection.

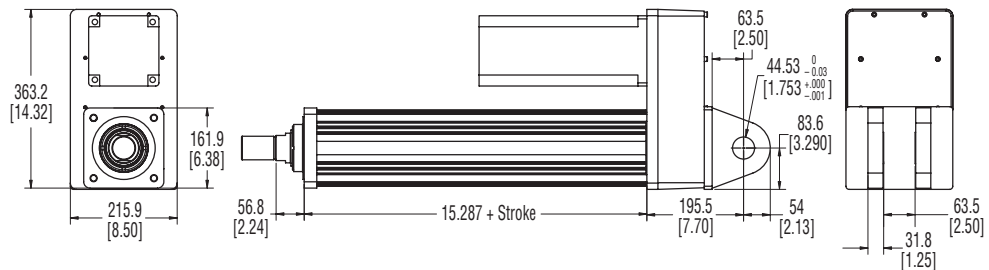

## FT60 Linear Actuator Front Flange Unit

Parallel motor mount shown.

All dimensions shown in millimeters with inch-equivalents in brackets.

See rod ends for rod end thread details.

Motor plate and cover dimensions are subject to change depending on the motor selection.

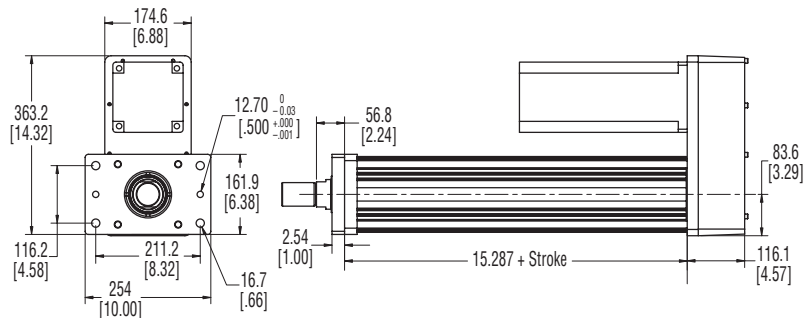

## FT60 Linear Actuator Rear Flange Unit

Parallel motor mount shown.

All dimensions shown in millimeters with inch-equivalents in brackets.

See rod ends for rod end thread details.

Motor plate and cover dimensions are subject to change depending on the motor selection.

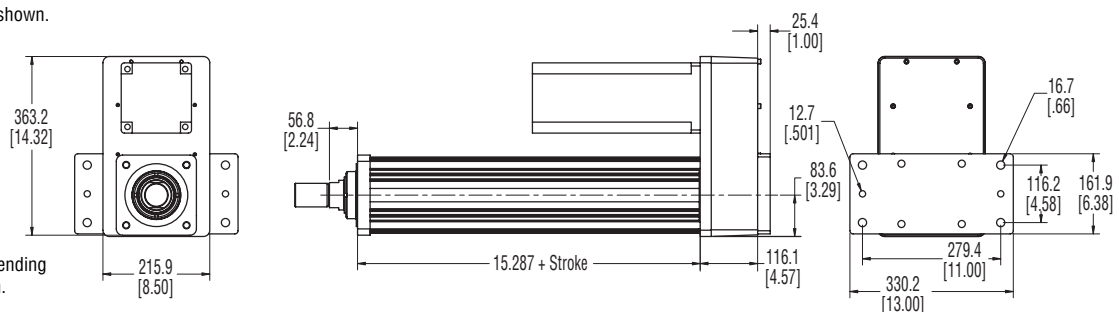

## FT60 Linear Actuator Trunnion Unit

Parallel motor mount shown.

All dimensions shown in millimeters with inch-equivalents in brackets.

See rod ends for rod end thread details.

Motor plate and cover dimensions are subject to change depending on the motor selection.

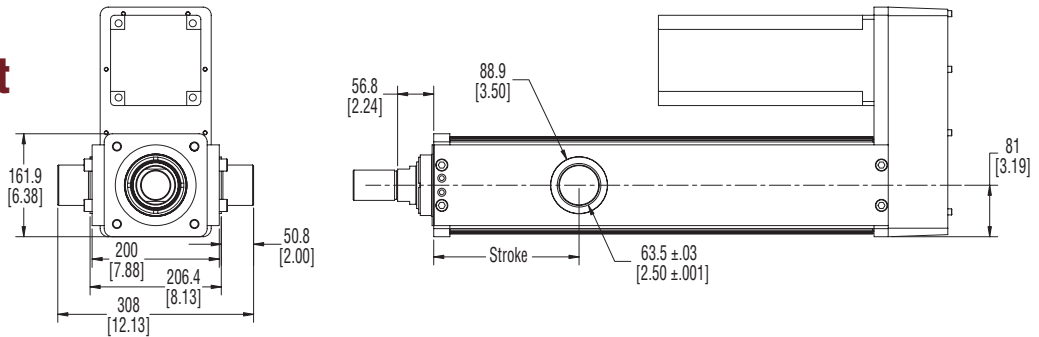

## FT60 Linear Actuator Extended Tie Rod Unit

Parallel motor mount shown.

All dimensions shown in millimeters with inch-equivalents in brackets.

See rod ends for rod end thread details.

Motor plate and cover dimensions are subject to change depending on the motor selection.

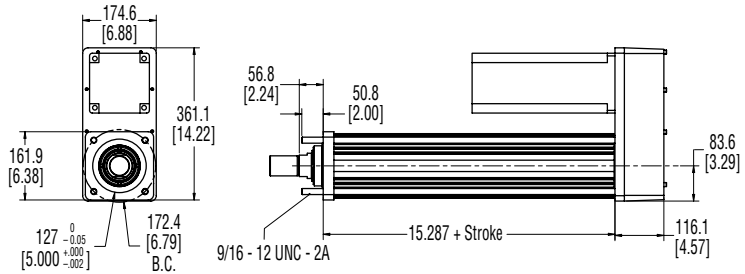

## FT60 Linear Actuator Side Lug Unit

Parallel motor mount shown.

All dimensions shown in millimeters with inch-equivalents in brackets.

See rod ends for rod end thread details.

Motor plate and cover dimensions are subject to change depending on the motor selection.

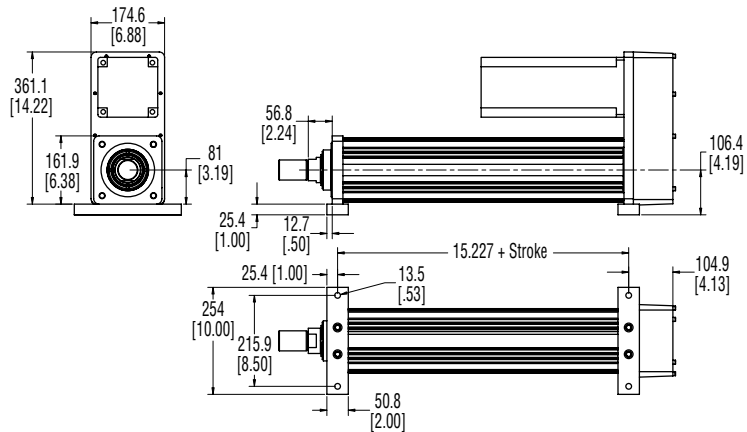

## FT60 Linear Actuator Side Mount Unit

Parallel motor mount shown.

All dimensions shown in millimeters with inch-equivalents in brackets.

See rod ends for rod end thread details.

Motor plate and cover dimensions are subject to change depending on the motor selection.

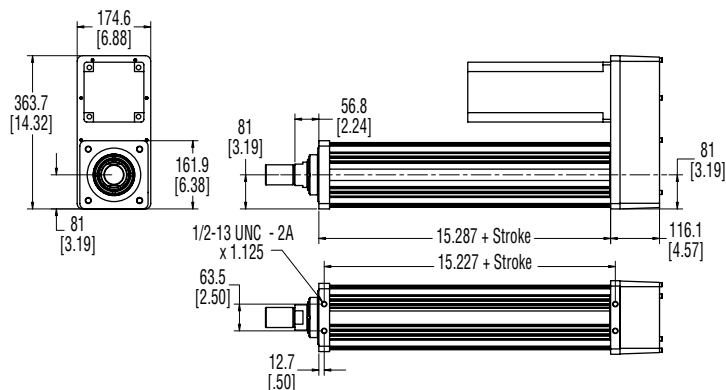

## FT80 Linear Actuator Base Unit

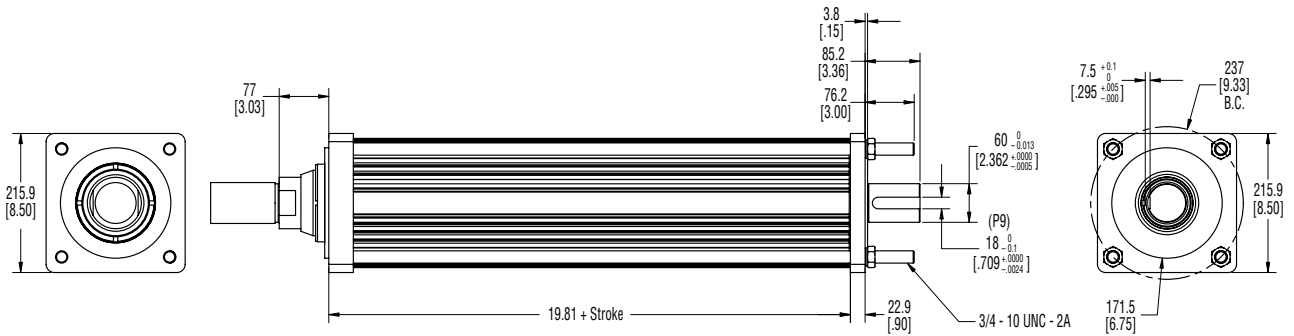

All dimensions shown in millimeters with inch-equivalents in brackets.  
See rod ends for rod end thread details.

## FT80 Linear Actuator Front Flange Unit

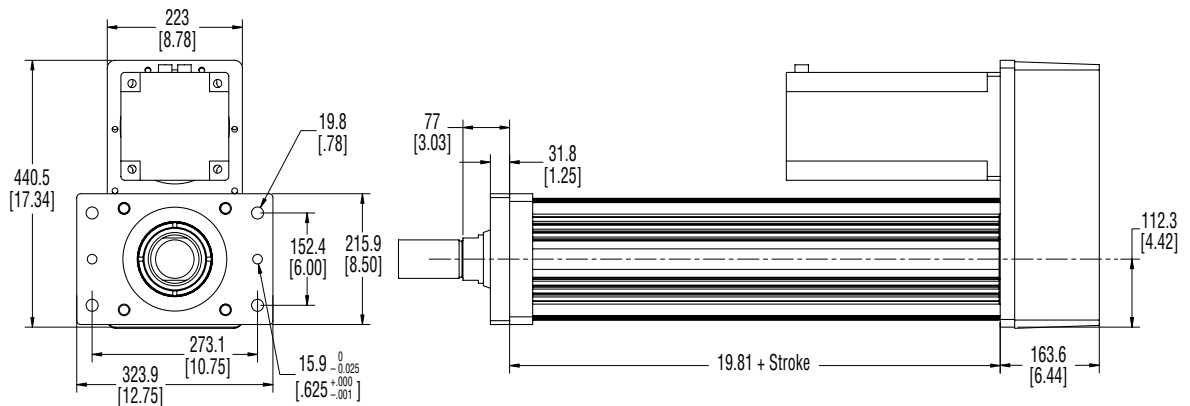

Parallel motor mount shown.  
All dimensions shown in millimeters with inch-equivalents in brackets.  
See rod ends for rod end thread details.  
Motor plate and cover dimensions are subject to change depending on the motor selection.



# FT Linear Actuator Rod End

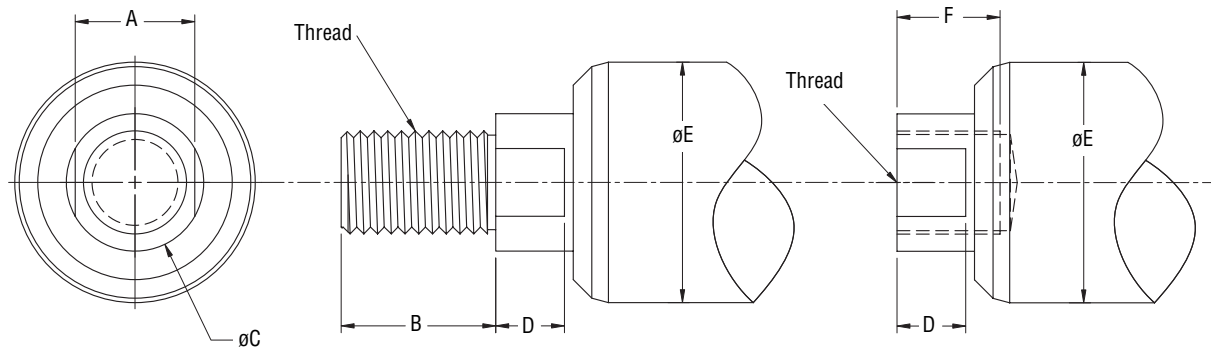

	A	B	$\phi C$	D	$\phi E$	F	Male U.S.	Male Metric	Female U.S.	Female Metric
<b>FT35</b>	0.87 (22.1)	1.125 (28.6)	1.000 (25.4)	0.500 (12.7)	1.750 (44.5)	0.750 (19.1)	3/4-16 UNF-2A	M16X1.5	3/4-16 UNF-2B	M16X1.5
<b>FT60</b>	2.00 (50.8)	2.750 (69.9)	2.360 (59.9)	0.750 (19.1)	3.000 (76.2)	2.000 (50.8)	1 7/8-12 UN-2A	M42X4.5	1 7/8-12 UN-2B	M42X4.5
<b>FT80</b>	2.75 (69.9)	4.019 (102.1)	3.143 (79.8)	1.000 (25.4)	4.000 (101.6)	2.250 (57.2)	2 1/2-12 UN-2A	M56X5.5	2 1/2-12 UN-2B	M56X5.5

Drawings subject to change. Consult Exlar for certified drawings.

<h2>FT Series Ordering Information</h2>	<div style="display: flex; justify-content: space-around; align-items: center;"> <div style="border: 1px solid black; padding: 2px 5px;">FTAA</div> <span>-</span> <div style="border: 1px solid black; padding: 2px 5px;">BBCC</div> <span>-</span> <div style="border: 1px solid black; padding: 2px 5px;">DEF</div> <span>-</span> <div style="border: 1px solid black; padding: 2px 5px;">GGG</div> <span>-</span> <div style="border: 1px solid black; padding: 2px 5px;">XX .. .. XX</div> </div>
<p><b>AA = FT Frame Size</b>  35 = 3.5 inch frame actuator  60 = 6.0 inch frame actuator  80 = 8.0 inch frame actuator</p>	<p><b>GGG = Motor Mount Provisions*</b>  (Please indicate the motor that will be used with the FT Actuator by it's 3 digit code.)  NMT = No motor mount – keyed shaft on base unit only  N34 = NEMA 34 motor mount  N42 = NEMA 42 motor mount  N56 = NEMA 56 motor mount  AB3,4,6,8 = Allen Bradley Ultra 3, 4, 6, &amp; 8 inch motors  BD3,4,6,8 = Baldor 3, 4, 6, &amp; 8 inch motors  CE3,4,6,8 = Parker(Custom Servo Motors) Imperial 3, 4, 6, &amp; 8 inch motors  CM3,4,6,8 = Parker(Custom Servo Motors) Metric 3, 4, 6, &amp; 8 inch motors  EC3,4,6,8 = ElectroCraft F&amp;H 3000, 4000, 6000 series, 8000 Series  EE3,4 = Emerson EMC Imperial 3 &amp; 4 inch  EM3,4,6,8 = Emerson EMC Metric 3, 4, 6, &amp; 8 inch  EX2,3,4,6 = Exlar SLM/SLG motors  FA 4,6,8 = Fanuc 4, 6 &amp; 8 inch motors  IN3,4,6,8 = Bosch- Rexroth (Indramat) 3, 4, 6, &amp; 8 inch motors  KM2,4,6,8 = Kollmorgen B &amp; M 20, 40, 60, &amp; 80 Series  MT3,4,6,8 = Mitsubishi 3,4,6 &amp; 8 inch motors  PS3,4,6,8 = Pacific Scientific PMA/PMB Series  PC2,3,4,6 = Parker Compumotor Apex 2.7, 3.6, 4.5, &amp; 5.6 inch  YS3,4,6,8 = Yaskawa 3, 4, 6, &amp; 8 inch motors  MXX = Unlisted or special motor mounting provisions</p>
<p><b>BB = Stroke Length</b>  06 = 6 inch (FT35)  12 = 12 inch (FT35, 60, 80)  18 = 18 inch (FT35)  24 = 24 inch (FT35, 60, 80)  36 = 36 inch (FT35, 60, 80)  48 = 48 inch (FT35, 60, 80)</p>	
<p><b>CC = Lead</b>  05 = 0.2 inch (FT35)  06 = 0.23 inch (FT60, 80)  10 = 0.39 inch (FT35)  12 = 0.47 inch (FT60, 80)  20 = 0.79 inch (FT35)  30 = 1.18 inch (FT60, 80)</p>	
<p><b>D = Mounting Style</b>  S = Side mount  L = Side lugs  E = Extended tie rods  C = Rear clevis (NA w/inline)  F = Front flange  T = Side trunnion mount  R = Rear flange (not available with inline motor mount)  B = Front / rear flange (not available with inline motor mount)  X = Special</p>	
<p><b>E = Motor Mounting Configurations</b>  N = None  I = Inline direct drive (includes Exlar standard coupling)  P = Parallel, 1:1 drive  Q = Parallel, 2:1 reduction  X = Special</p>	<p><b>XX .. XX = Options</b>  <b>Housing Options</b>  XH = Special housing options  XT = Special travel  SS = Stainless steel  FG = Food grade white epoxy  (IP65 sealing of unit with motor mounted require “XH” option.)</p> <p><b>Special Follower</b>  PF = Preloaded follower. The dynamic load rating of zero backlash, preloaded screws is 63% of the dynamic load rating of the standard non-preloaded screws. The calculated travel life of a preloaded screw will be 25% of the calculated travel life of the same size and lead non-preloaded screw for the same application.  FX = Special follower</p> <p><b>End Switches</b> (adjustable position throughout stroke)  L1 = One adjustable switch, (10-30 VDC, PNP, N.C., 1m. 3 wire embedded cable)  L2 = Two adjustable switches, (10-30 VDC, PNP, N.C., 1m. 3 wire embedded cable)  L3 = Three adjustable switches, (10-30 VDC, PNP, N.C., 1m. 3 wire embedded cable)</p> <p><b>Please provide a drawing of motor dimensions with all orders to insure proper mounting compatibility.</b></p> <p>*Mounting face size, shaft length and other details of particular motors may require special adapters or provisions for mounting. Always discuss your motor selection with Exlar engineering.</p>
<p><b>F = Rod End</b>  M = Male, U.S. standard  F = Female, U.S. standard  A = Male, metric  B = Female, metric  X = Special</p>	

Consult Exlar's Application Engineering Department regarding all special actuator components.