

UNIMOTION

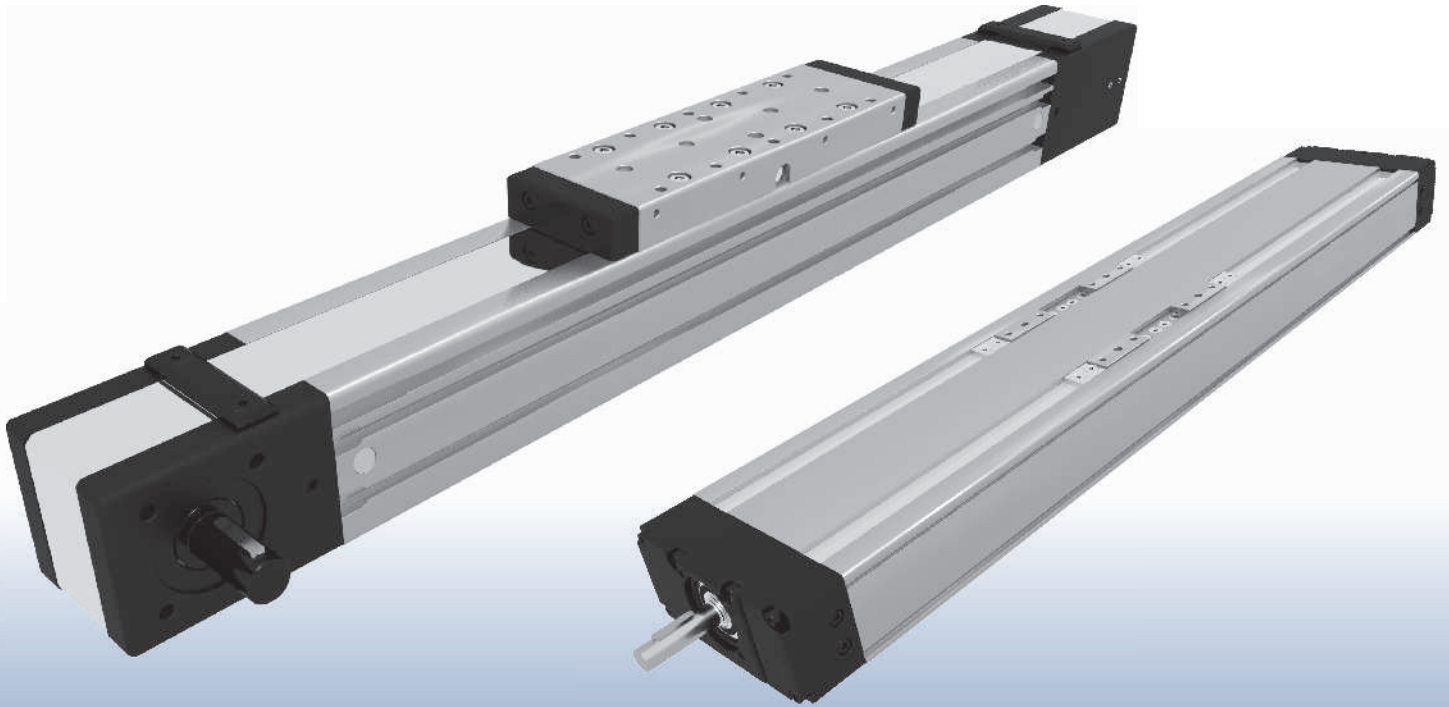

LINEAR UNITS

www.unimotion.eu



Our company was established in 1990 and, since then, it is privately owned. After 7 years of experience in metal processing as a contractor, the company Hypex (Unimotion) was created and operated in the following areas:

Special purpose machinery manufacture with its own development, trade and assembly in the area of industrial automation. Due to many years of engineering and substantial engagement in individual problem solving processes, extensive knowledge and experience in the development and manufacture of linear and handling systems were gained. Today we produce mechanical linear units, compact linear units, multi-axis systems as well as customised solutions for high dynamic demands. Our company's premises, which cover an area of 4500m², offer room for our 40 employees. Production, construction, administration and warehouse; all this can be found under one roof.

Our modern machinery with CNC machining centres and CNC automatic lathes enables high-precision manufacture and really high in-house production depth. For example, we ourselves manufacture shaft drives with tooth washers and our screw ends. This is why, quality, reliability, a good price/performance ratio and short delivery times are harmonised to perfection. Thus, in the production of our standard linear units as well as individual and complex special linear units, we can guarantee high capacity, flexibility and precision.

It goes without saying that our company is certified in accordance with DIN ISO 9001:2008. At the moment, we export our products in more than 23 countries. Inspired by our customers' demands, Hypex (Unimotion) constantly develops new products and system solutions. So you are welcome to contact us. We look forward to meet you and work on your special project!



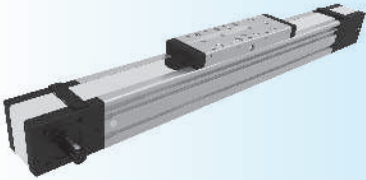
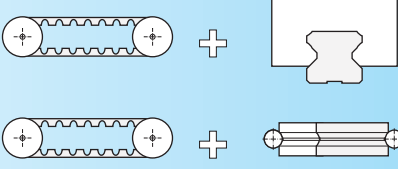

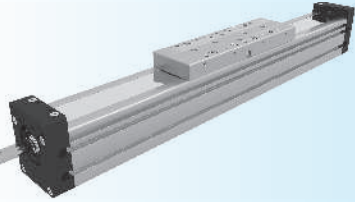
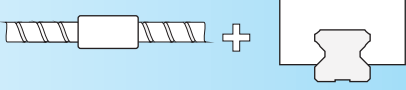

MTJ
MRJ
1.000.0

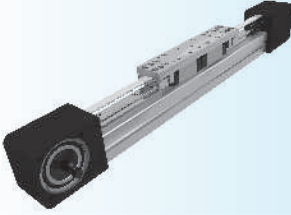

MTV
2.000.0

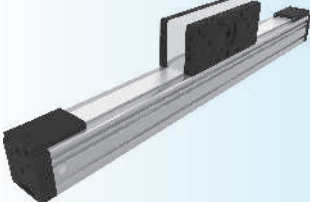

MTJ ECO
3.000.0

MTJZ
4.000.0

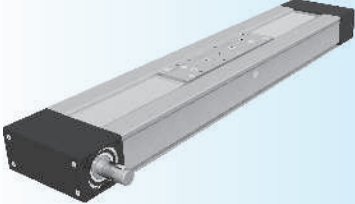
CTJ
5.000.0

CTV
6.000.0

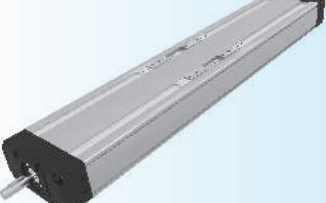

ACCESSORIES
7.000.0

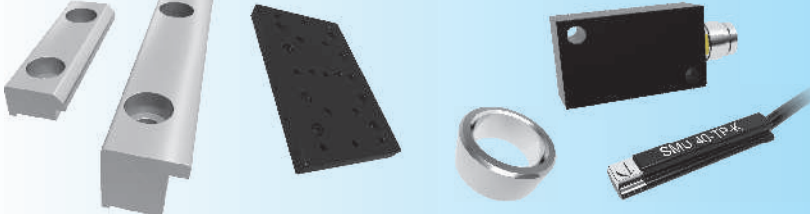
CHARACTERISTICS

MTJ and MRJ Linear Units with toothed belt drive and compact dimensions provide high performance features such as, high speed, good accuracy and repeatability.

They can easily be combined to multi-axis systems.

Excellent price-/performance ratio and quick delivery time are ensured.

The compact, precision-extruded aluminum Profile from 6063 AL with integrated Zero-backlash Ball rail guide system, allows high load capacities and optimal cycles for the movement of larger masses at high speed.

For very high speeds, up to 10m/s, the Track Rollers (journal Bearings) of the type MRJ are particularly suitable.

In the Linear Units MTJ and MRJ is used a pre-tensioned steel reinforced AT polyurethane timing toothed belt. In conjunction with a Zero-backlash drive pulley high moments with alternating loads with good positioning accuracy, low wear and low noise can be realized.

The in the Profile slot driving Polyurethane timing belt protects all the parts in the Profile from dust and other contaminations. As optional, a corrosion-resistant protection strip is available.

The aluminum profile includes T-slots for fixing the Linear Unit and for attaching sensors and switches. Also, a Reed switch can be used here.

Different carriage lengths with central lubrication port, allow easy re-lubrication of the Linear Unit and allow the possibility to attach additional accessories on the side.

For the Linear Units MTJ and MRJ various adaptation options, for attaching (or redirecting), for Motors or Gearboxes are available.

MTJ

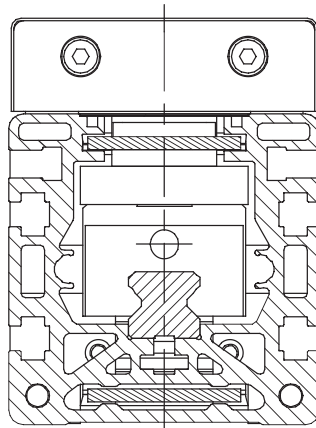

MRJ

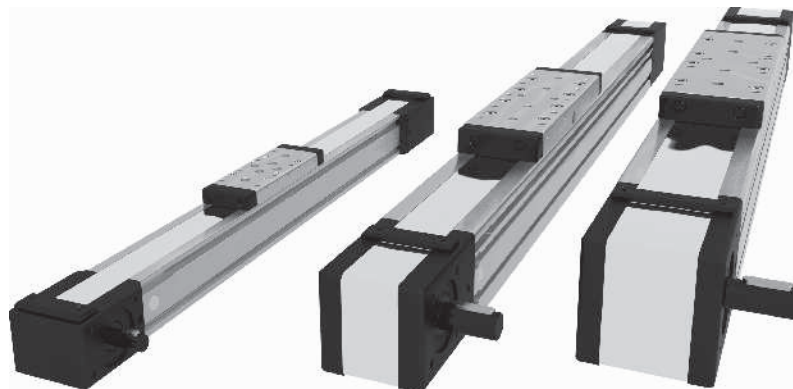
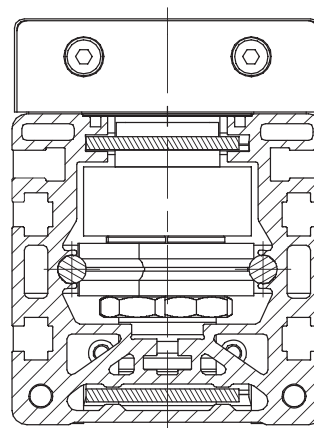

The aluminium profiles are manufactured according to the medium EN 12020-2 standard /

Straightness = 0,35 mm/m; Max. torsion = 0,35 mm/m; Angular torsion = 0,2 mm/40 mm; Parallelism = 0,2 mm

STRUCTURAL DESIGN

MTJ Series

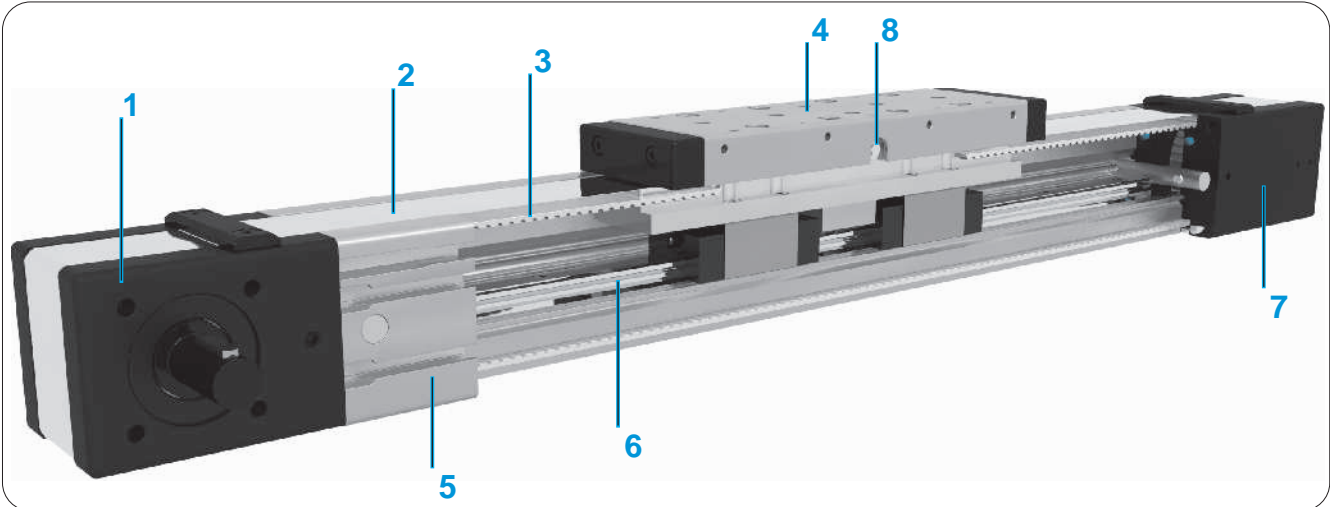

- 1 - Drive block with pulley
- 2 - Corrosion-resistant protection strip (available also without protection strip)
- 3 - AT polyurethane toothed belt with steel tension cords.
- 4 - Carriage; with built in Magnets
- 5 - Aluminium profile-Hard anodized
- 6 - Linear Ball Guideway
- 7 - Tension End with integrated belt tensionin system
- 8 - One central lubrication port

MRJ Series

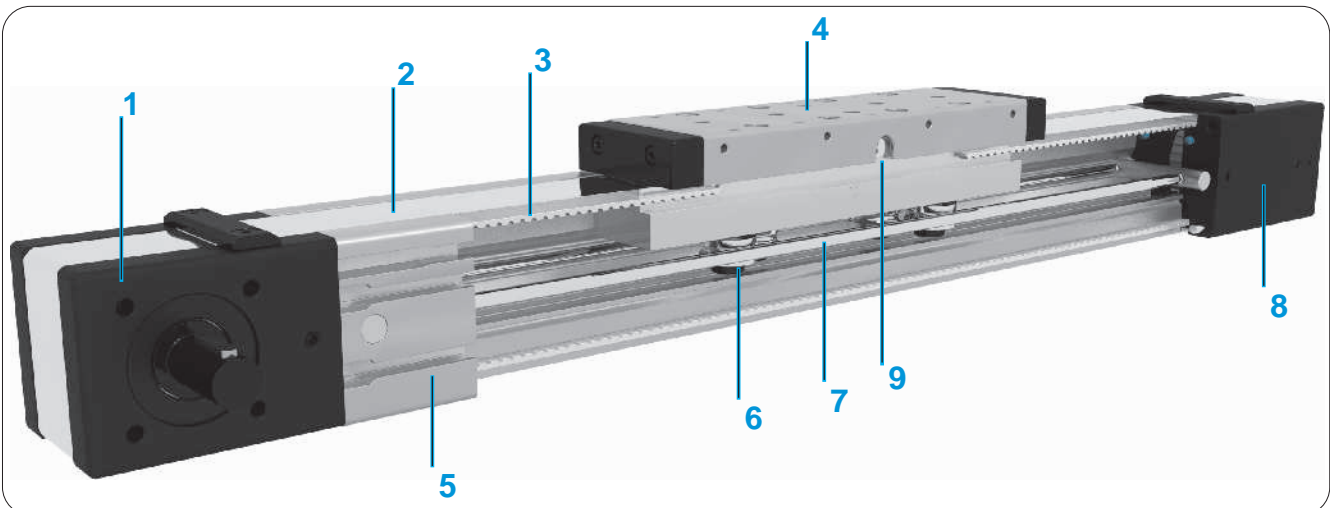

- 1 - Drive block with pulley
- 2 - Corrosion-resistant protection strip (available also without protection strip)
- 3 - AT polyurethane toothed belt with steel tension cords.
- 4 - Carriage; with build in Magnets
- 5 - Aluminium profile-Hard anodized
- 6 - Track Roller (journal Bearing)
- 7 - Two hardened steel Round guide (58/60 HRC)
- 8 - Tension End with integrated belt tensionin system
- 9 - One central lubrication port

HOW TO ORDER



Series :

- MRJ
- MTJ

Size :

- 40
- 65
- 80
- 110

Absolute stroke (mm) :

Carriage Version :

S : Short (only for MTJ series)

L : Long

Without : MRJ 40, MTJ 40

Type of drive pulley :

- 0 : Pulley with through hole
- 1 : Pulley with journal (with Keyway)
- 10 : Pulley with journal (without Keyway)
- 2 : Pulley with journal on both sides (with Keyway)
- 20 : Pulley with journal on both sides (without Keyway)
- 3 : Without drive unit

Drive journal position :

L : Journal on left side

R : Journal on right side

Without : For type of drive pulley 0, 2 and 3

Protection cover :

0 : In profile groove guided Polyurethane toothed belt

1 : Corrosion-resistant protection strip

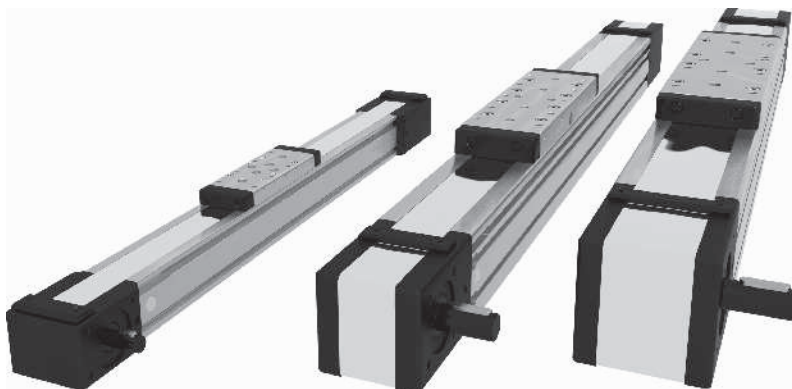

TECHNICAL DATA

General technical data for MTJ series

Linear Unit	Carriage length Lv [mm]	Load capacity		Dynamic moment			Moved mass [kg]	Maximum Repeatability [mm]	* Maximum length Lmax [mm]	Planar moment of inertia	
		Dynamic C [N]	Static C0 [N]	Mx [Nm]	My [Nm]	Mz [Nm]				ly [cm ⁴]	lz [cm ⁴]
MTJ 40	92	4616	6930	28,6	90	90	0,28	± 0,08	2000	9,83	11,57
MTJ 65 S	140	6848	9754	68	51	51	1,00	± 0,08	6000	59,1	73,8
MTJ 65 L	190	13697	19508	136	712	712	1,45	± 0,08			
MTJ 80 S	170	15339	21707	206	146	146	1,72	± 0,08	6000	132,3	175,2
MTJ 80 L	260	30678	43415	402	2300	2300	2,72	± 0,08			
MTJ 110 S	240	22246	30767	344	250	250	3,25	± 0,08	6000	513,0	620,0
MTJ 110 L	330	44492	61536	688	3448	3448	4,61	± 0,08			

*For lengths over the stated value in the table above please contact us

General technical data for MRJ series

Linear Unit	Carriage length Lv [mm]	Dynamic load capacity		Dynamic moment			Moved mass [kg]	Maximum Repeatability [mm]	* Maximum length Lmax [mm]	Planar moment of inertia	
		Cy [N]	Cz [N]	Mx [Nm]	My [Nm]	Mz [Nm]				ly [cm ⁴]	lz [cm ⁴]
MRJ 40	92	3260	1918	23	59	59	0,26	± 0,08	6000	9,83	11,57
MRJ 65 L	190	8200	4825	82	237	237	1,31	± 0,08	6000	59,1	73,8
MRJ 80 L	260	16600	9765	214	764	764	2,73	± 0,08	6000	132,3	175,2
MRJ 110 L	330	29000	17060	495	1582	1582	4,78	± 0,08	6000	513,0	620,0

*For lengths over the stated value in the table above please contact us



Recommended values of loads

All the data of static and dynamic moments and load capacities stated in the upper table are theoretical without considering any safety factor. The safety factor depends on the application and its requested safety. We recommend a minimum safety factor (fv =5.0)

Modulus of elasticity :

E = 70000 N / mm

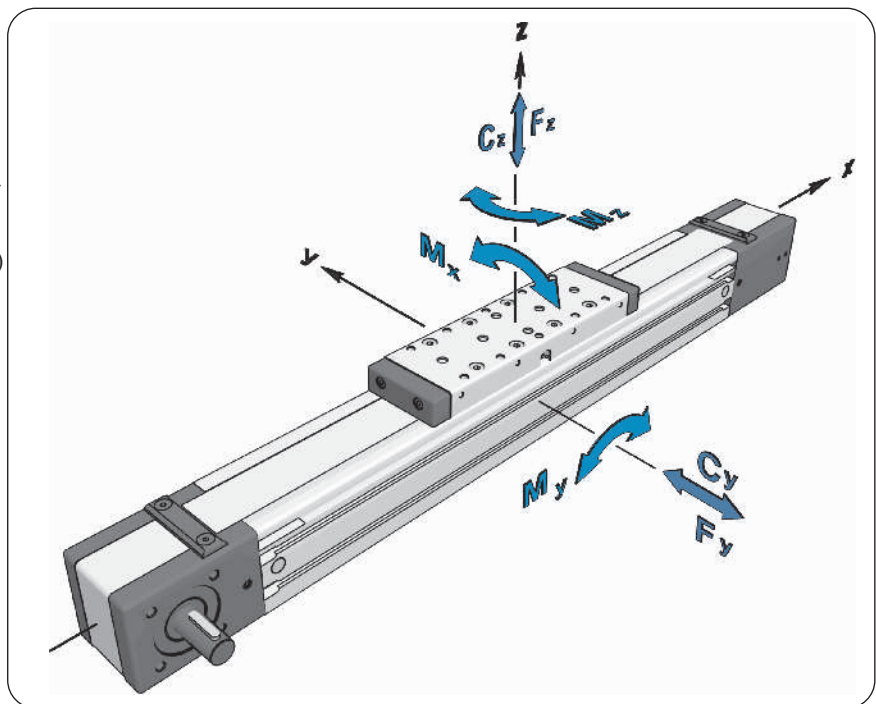

TECHNICAL DATA

Drive and belt data for MRJ and MTJ series

Linear Unit	* Maximum travel speed [m / s]	Maximum drive torque Ma [Nm]	** No load torque		Puley drive ratio [mm / rev]	Pulley diameter [mm]	Belt type	Belt width [mm]	Max. force transmitted by belt [N]	Limit of belt elasticity [N]	Specific spring constant Cspec [N]
			With strip [Nm]	Without strip [Nm]							
MRJ 40	10	3,7	0,4	0,2	99	31,51	AT 3	20	235	900	225000
MTJ 40	6		0,4	0,2							
MRJ 65 L	10	13,1	1	0,7	165	52,52	AT 5	32	500	2400	600000
MTJ 65 S	6		1,1	0,8							
MTJ 65 L			1,2	0,9							
MRJ 80 L	10	29,4	1,4	1,1	210	66,84	AT 5	50	880	3840	960000
MTJ 80 S	6		1,5	1,2							
MTJ 80 L			1,7	1,4							
MRJ 110 L	10	82,6	1,8	1,5	300	95,49	AT 10	50	1730	8580	2145000
MTJ 110 S	6		1,8	1,5							
MTJ 110 L			2	1,7							

* Maximum travel speed of Linear unit with the Corrosion-resistant protection strip is 1,5 m/s

** The stated values are for strokes up to 500mm. No Load Torque value increases with stroke elongation

Mass and mass moment of inertia for MTJ series

Linear Unit	Carriage length Lv [mm]	Mass of linear unit [kg]	Mass moment of inertia [10 ⁻⁵ kg·m ²]
MTJ 40	92	1,3 + 0,0024 * Stroke [mm]	9,7 + 0,003 * Stroke [mm]
MTJ 65 S	140	4 + 0,0055 * Stroke [mm]	98,4 + 0,015 * Stroke [mm]
MTJ 65 L	190	4,6 + 0,0055 * Stroke [mm]	130,1 + 0,015 * Stroke [mm]
MTJ 80 S	170	6,8 + 0,0085 * Stroke [mm]	310,6 + 0,039 * Stroke [mm]
MTJ 80 L	260	8,4 + 0,0085 * Stroke [mm]	423,3 + 0,039 * Stroke [mm]
MTJ 110 S	240	15 + 0,015 * Stroke [mm]	1065,0 + 0,137 * Stroke [mm]
MTJ 110 L	330	17,7 + 0,015 * Stroke [mm]	1381,0 + 0,137 * Stroke [mm]

Mass and mass moment of inertia for MRJ series

Linear Unit	Carriage length Lv [mm]	Mass of linear unit [kg]	Mass moment of inertia [10 ⁻⁵ kg·m ²]
MRJ 40	92	1,25 + 0,0022 * Stroke [mm]	9,3 + 0,003 * Stroke [mm]
MRJ 65 L	190	4,3 + 0,0047 * Stroke [mm]	119,6 + 0,015 * Stroke [mm]
MRJ 80 L	260	8,2 + 0,0075 * Stroke [mm]	424,9 + 0,039 * Stroke [mm]
MRJ 110 L	330	16,3 + 0,0133 * Stroke [mm]	1420,0 + 0,137 * Stroke [mm]



Mass calculation doesn't include mass of motor, reduction gear, switches and clamps.

DIMENSIONS

Linear Unit doesn't include any safety stroke.

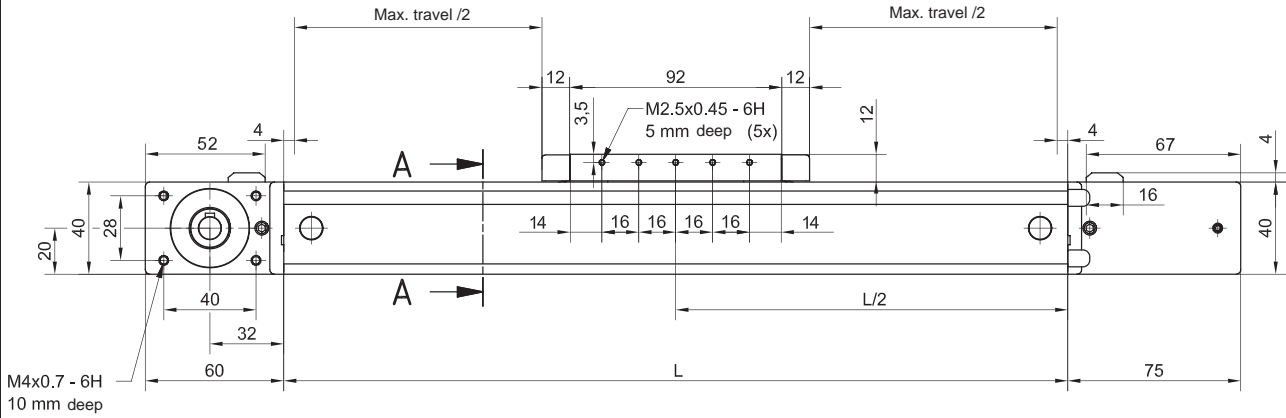

Lifetime lubricated!

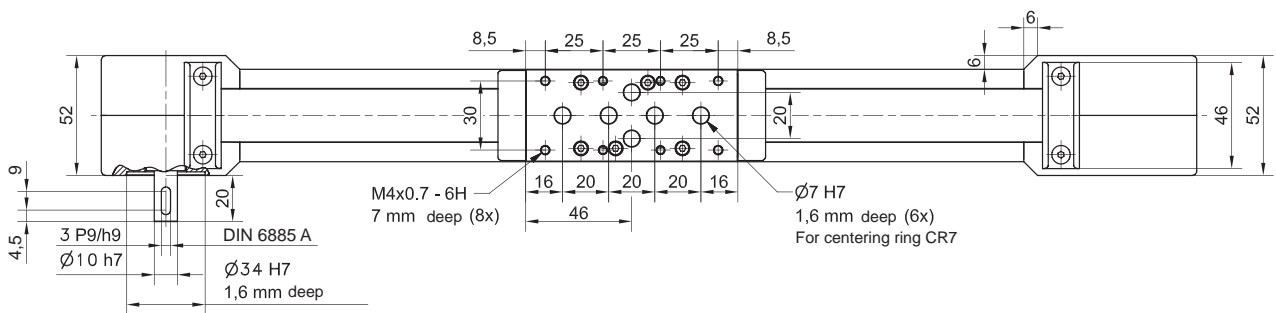

Journal with or without Keyway.

All dimensions in mm; Drawings scales are not equal.

TYPE 0

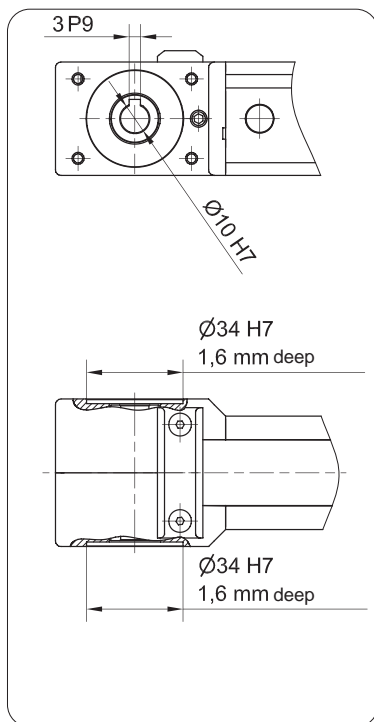

TYPE 1 L and 1 R

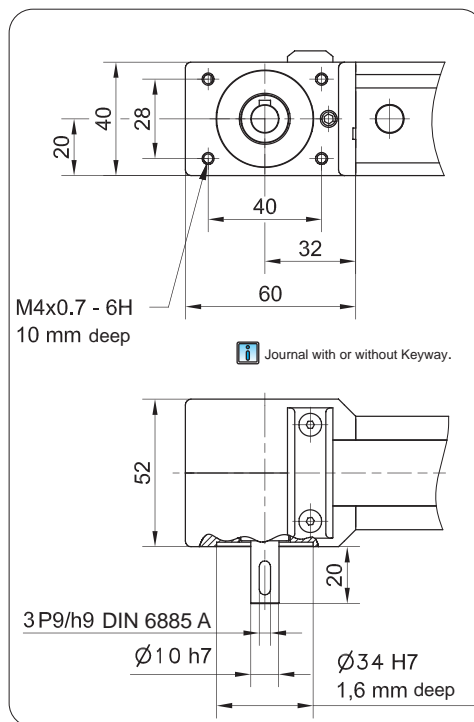

TYPE 2

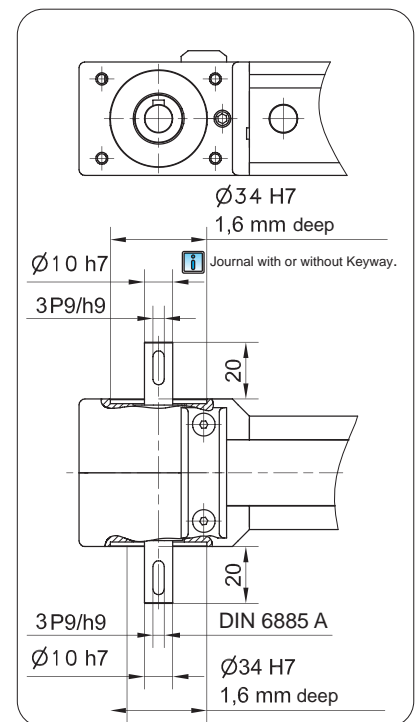

DIMENSIONS

MTJ 40

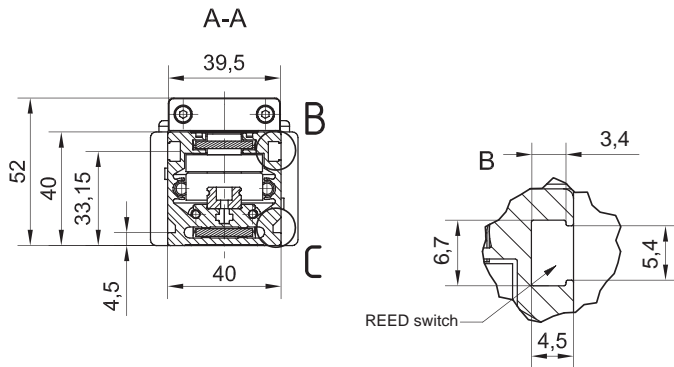

MRJ 40

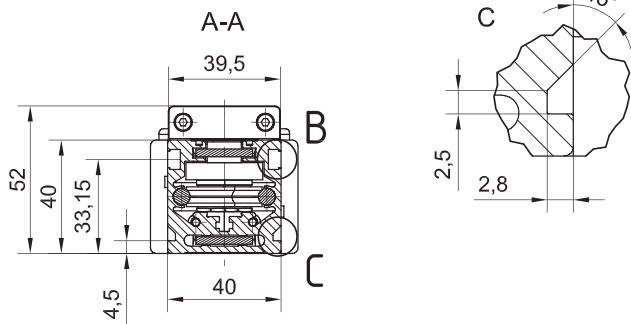

All dimensions in mm; Drawings scales are not equal.

CENTERING RING CR7
Material: 1.4305 (AISI303)

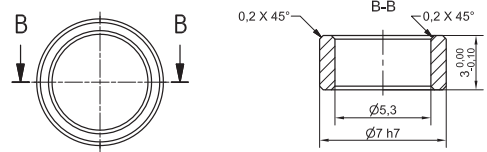

TAP / PIN holes on bottom of the profile available on request.

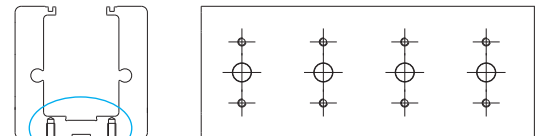

TAP / PIN holes on bottom of the profile
 Drawing only for presentational use.

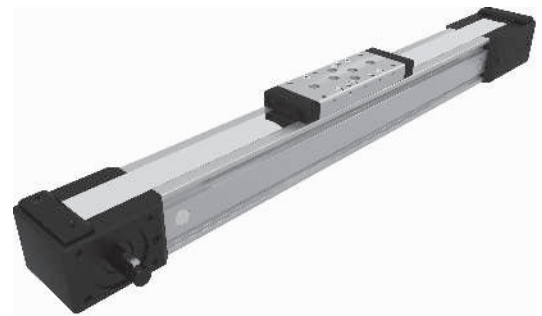

MOTOR	MTJ & MRJ 40	MTJ & MRJ 40	MTJ & MRJ 40
GEAR REDUCER + MOTOR	MTJ & MRJ 40	MTJ & MRJ 40	MTJ & MRJ 40
GEAR RED. 90° + MOTOR	MTJ & MRJ 40	MTJ & MRJ 40	MTJ & MRJ 40
	Available on request	Available on request	Available on request

Defining of the linear module length

$L = \text{Effective stroke} + 2 \times \text{Safety travel} + L_v + 32 \text{ mm}$

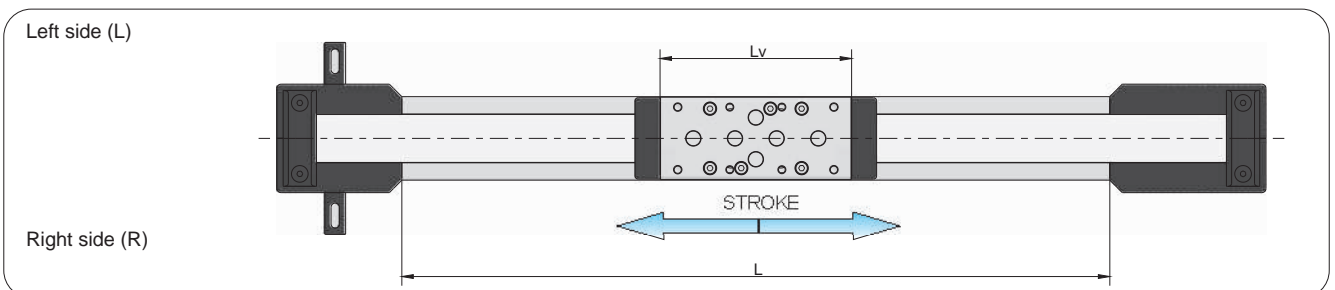

Double-Carriage

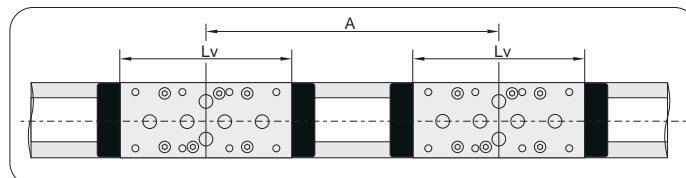

For ordering code please contact us.

$L = \text{Effective stroke} + 2 \times \text{Safety travel} + L_v + A + 32 \text{ mm} \quad \} \quad A \geq L_v + 24 \text{ mm}$



DIMENSIONS

Linear Unit doesn't include any safety stroke.

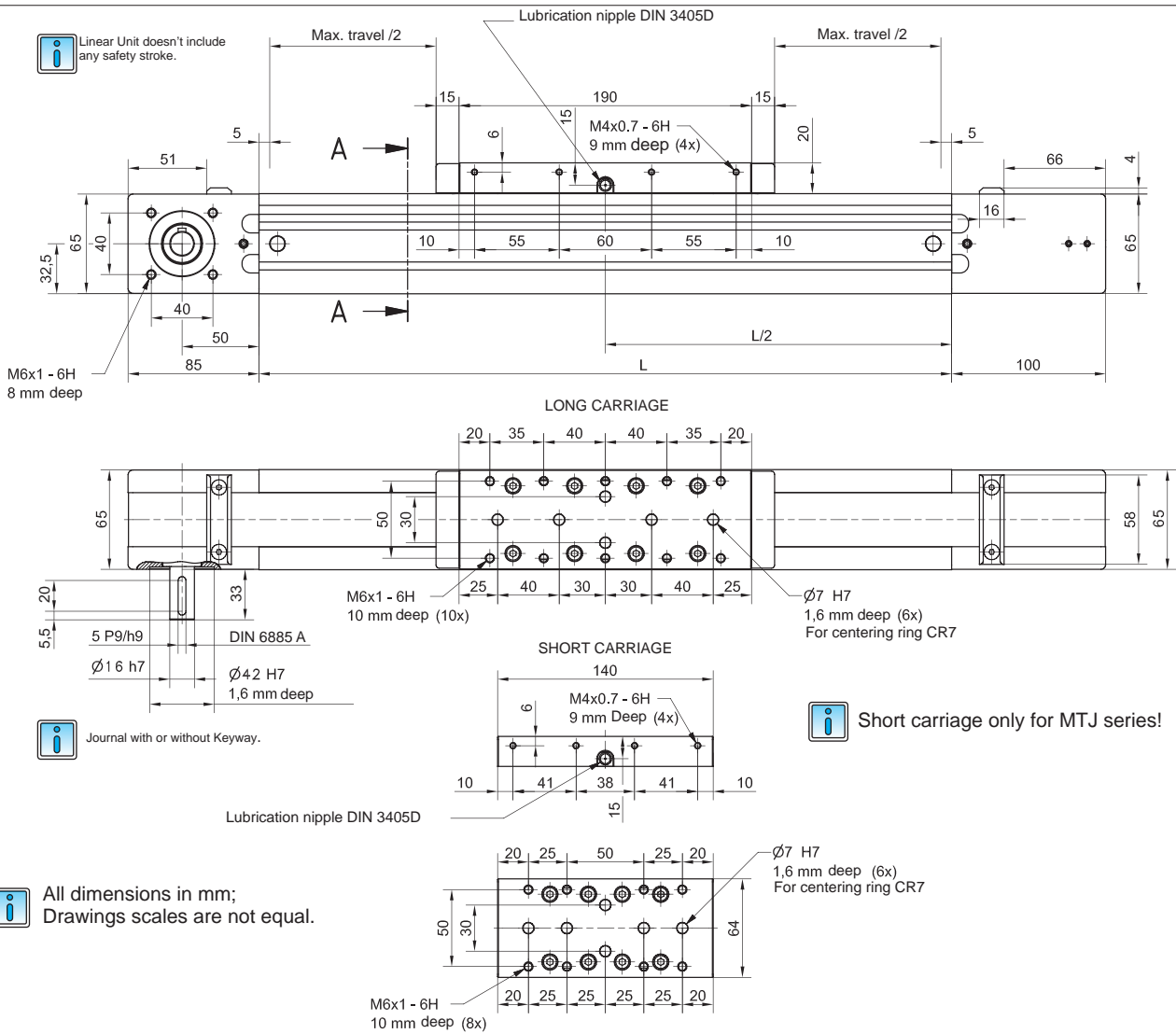

TYPE 0

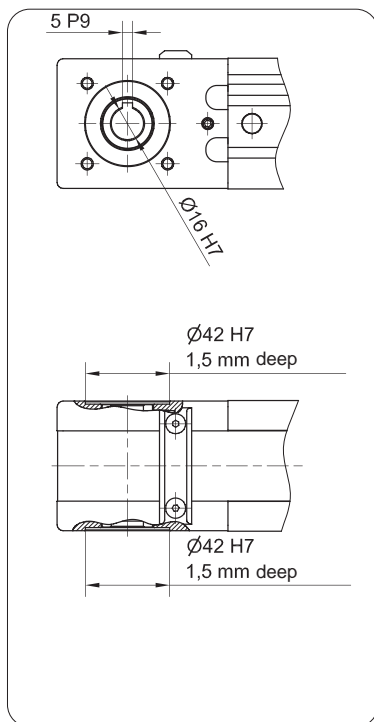

TYPE 1 L and 1 R

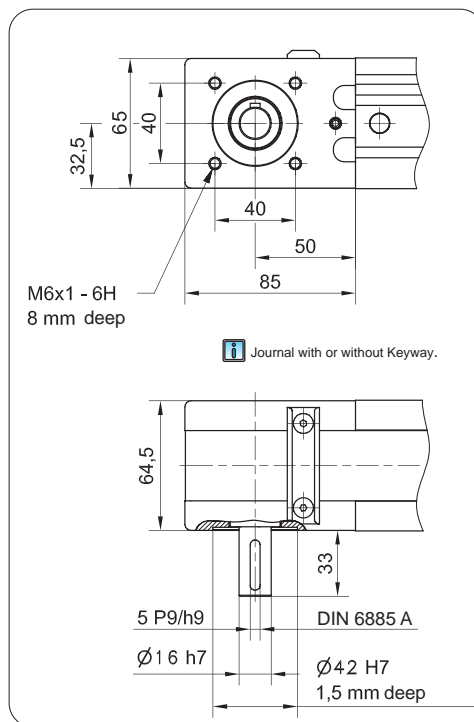

TYPE 2

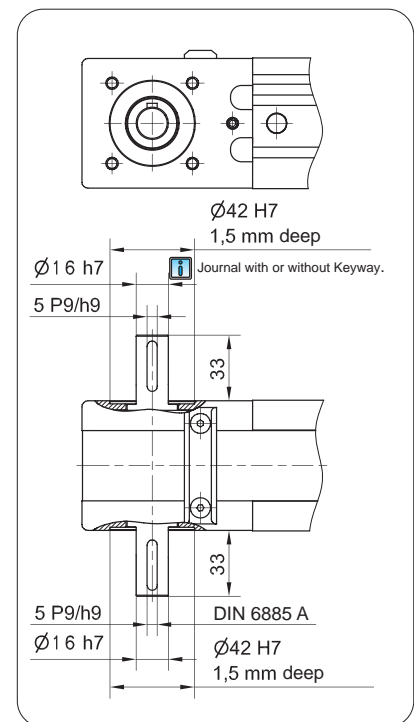

DIMENSIONS

MTJ 65

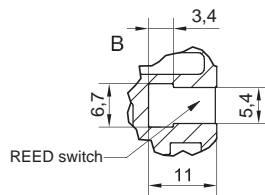
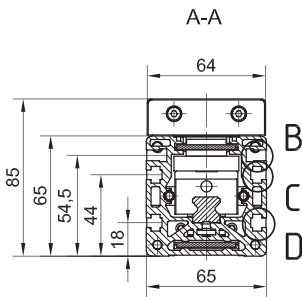

MRJ 65

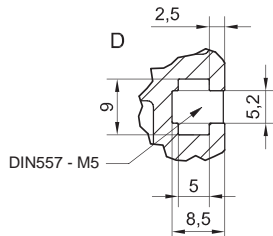
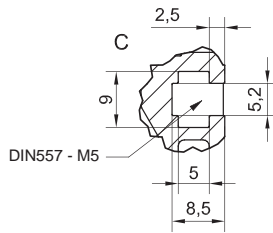
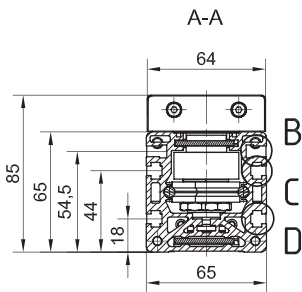

All dimensions in mm; Drawings scales are not equal.

CENTERING RING CR7
Material: 1.4305 (AISI303)

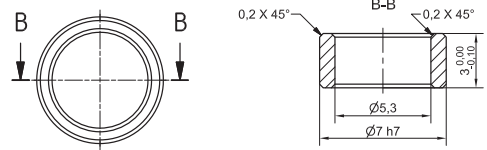

TAP / PIN holes on bottom of the profile available on request.

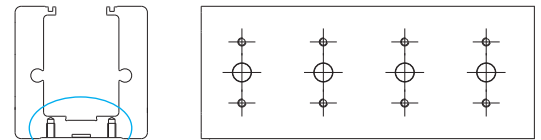

TAP / PIN holes on bottom of the profile
 Drawing only for presentational use

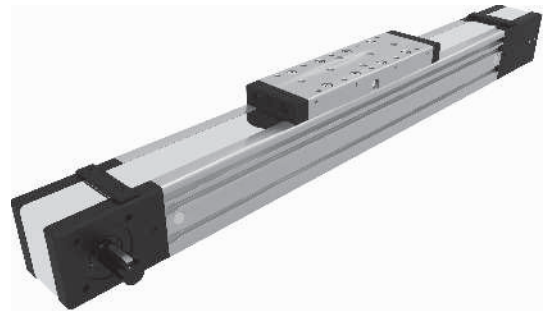

MOTOR	MTJ & MRJ 65	MTJ & MRJ 65	MTJ & MRJ 65
	Available on request	Available on request	Available on request
GEAR REDUCER + MOTOR	MTJ & MRJ 65	MTJ & MRJ 65	MTJ & MRJ 65
	Available on request	Available on request	Available on request
GEAR RED. 90° + MOTOR	MTJ & MRJ 65	MTJ & MRJ 65	MTJ & MRJ 65
	Available on request	Available on request	Available on request

Defining of the linear module length

$L = \text{Effective stroke} + 2 \times \text{Safety travel} + L_v + 40 \text{ mm}$

Left side (L)

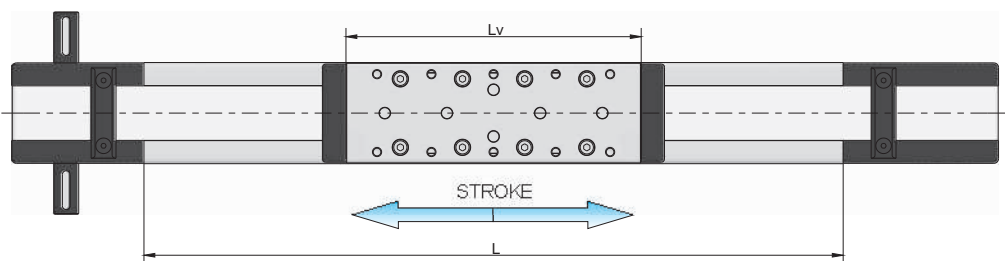

Right side (R)

Double-Carriage

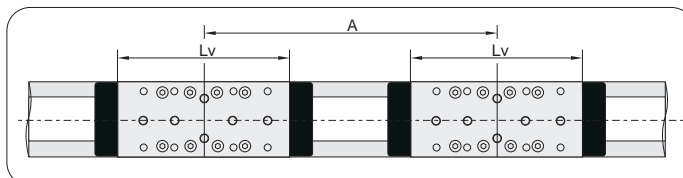

For ordering code please contact us.

$L = \text{Effective stroke} + 2 \times \text{Safety travel} + L_v + A + 40 \text{ mm}$ } $A \geq L_v + 30 \text{ mm}$



DIMENSIONS

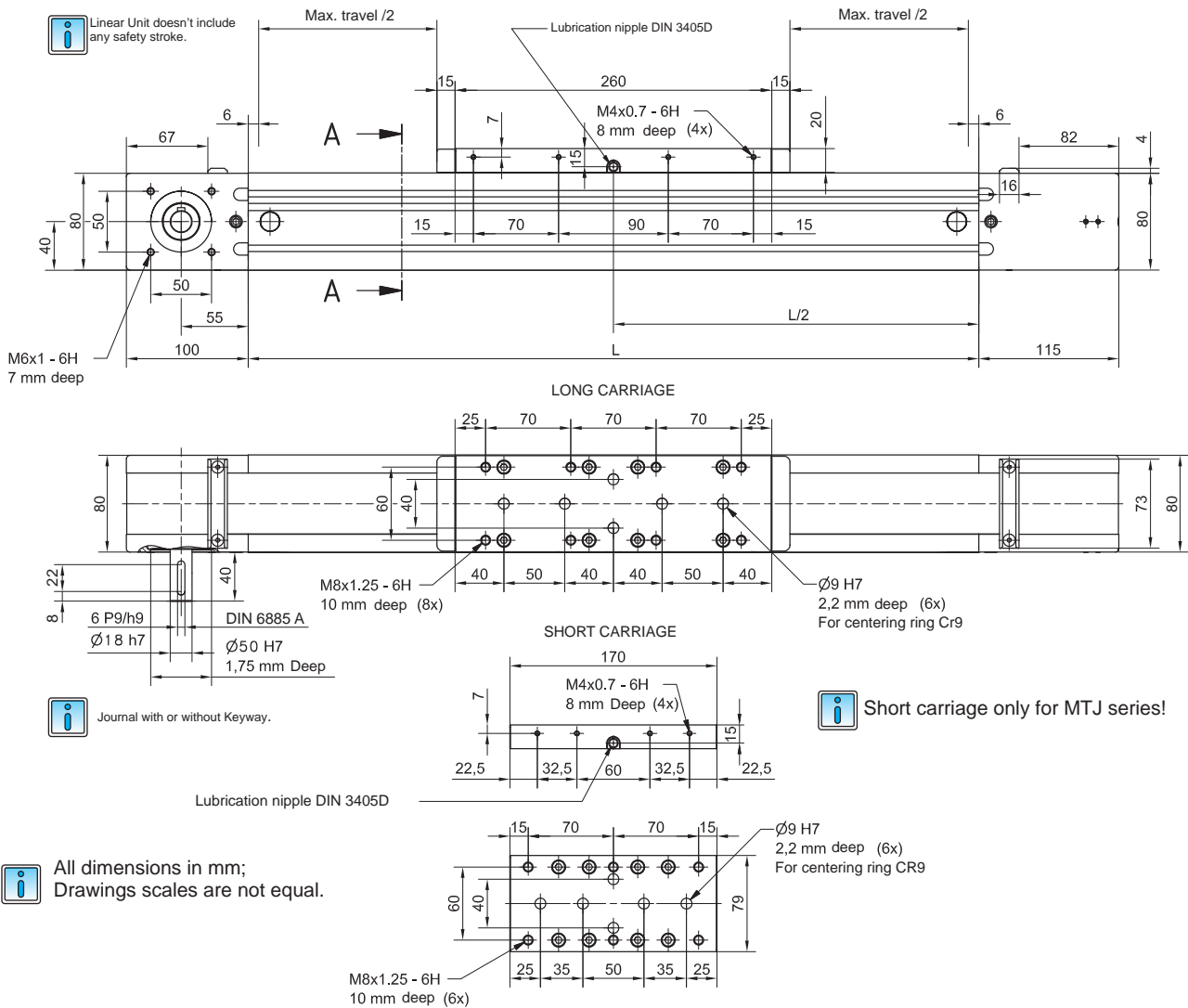

TYPE 0

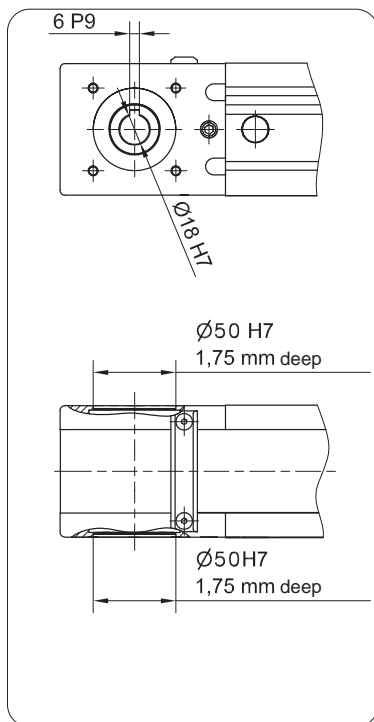

TYPE 1 L and 1 R

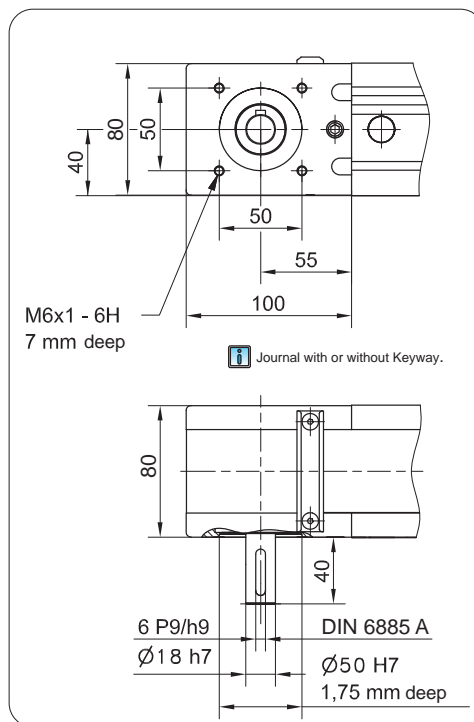

TYPE 2

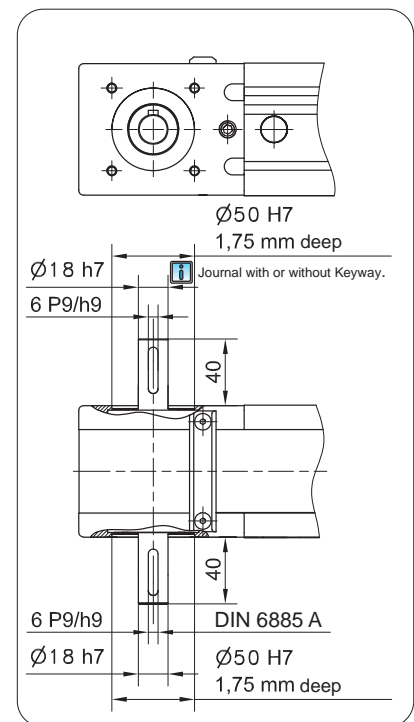

DIMENSIONS

i Linear Unit doesn't include any safety stroke.

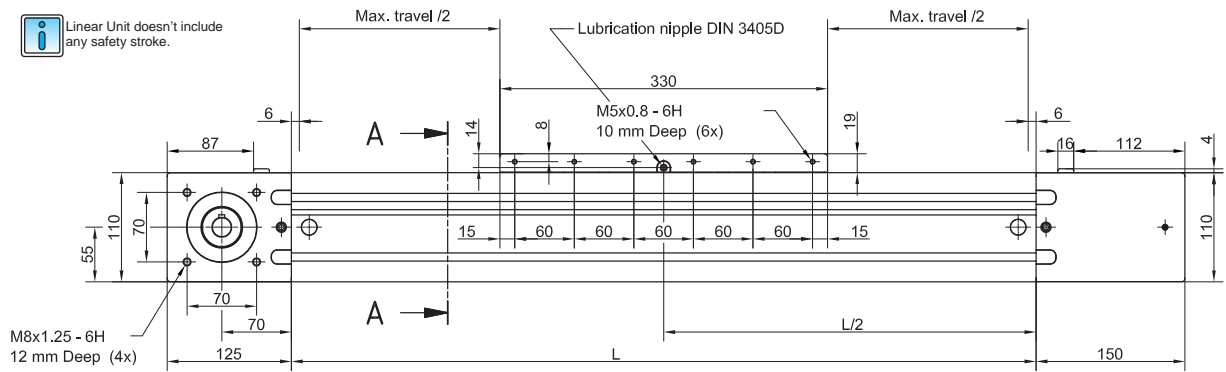

LONG CARRIAGE

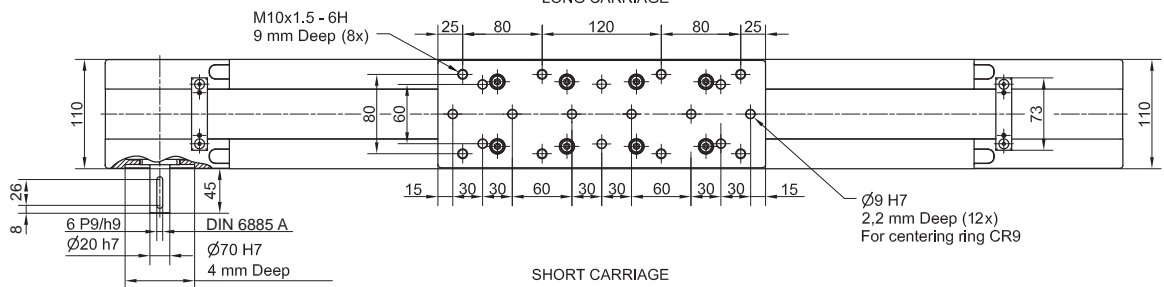

SHORT CARRIAGE

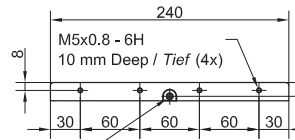

i Short carriage only for MTJ series!

i Journal with or without Keyway.

Ø9 H7
2,2 mm Deep / Tief (6x)
For centering ring CR9

i All dimensions in mm;
Drawings scales are not equal.

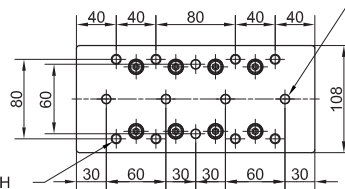

TYPE 0

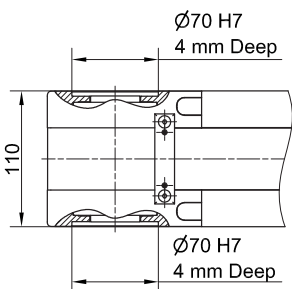
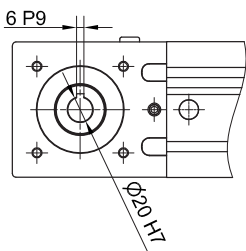

TYPE 1 L and 1 R

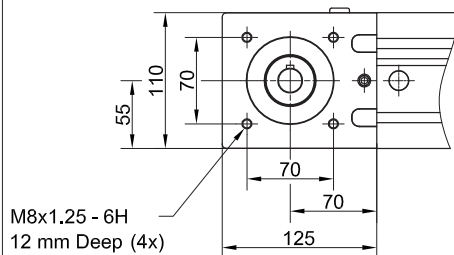

i Journal with or without Keyway.

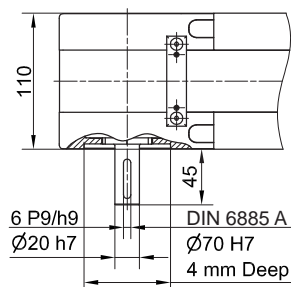

TYPE 2

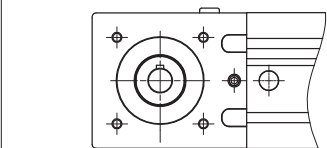

i Journal with or without Keyway.

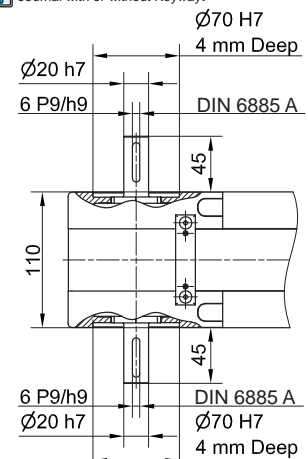

CHARACTERISTICS

The **MTV** series describes Linear Units with precision ball screw drive, integrated guide rail and compact dimensions. They provide high performances features, such as high speeds, good accuracy and repeatability.

They can easily be combined to multi-axis systems.

Excellent price-/performance ratio and quick delivery time are ensured.

The compact, precision-extruded aluminum Profile from 6063 AL with integrated Zero-backlash Ball rail guide system, allows high load capacities and optimal cycles for the movement of larger masses at high speed.

In the Linear Units MTV a precision ball screw, with tolerance class ISO7 (ISO5 on request), with reduced backlash of the ball nut is used.

A corrosion-resistant protection strip, protects all the parts in the profile from dust and other contaminants.

The aluminum profile includes T-slots for fixing the Linear Unit and for attaching sensors and switches. Also, a Reed switch can be used here.

The carriage, with central lubrication port, allows easy central re-lubrication of ball screw and Ball rail guide and provides the possibility to attach additional accessories on the side.

For the Linear Units MTV various adaptation options, for attaching (or redirecting), for Motors or Gearboxes are available.

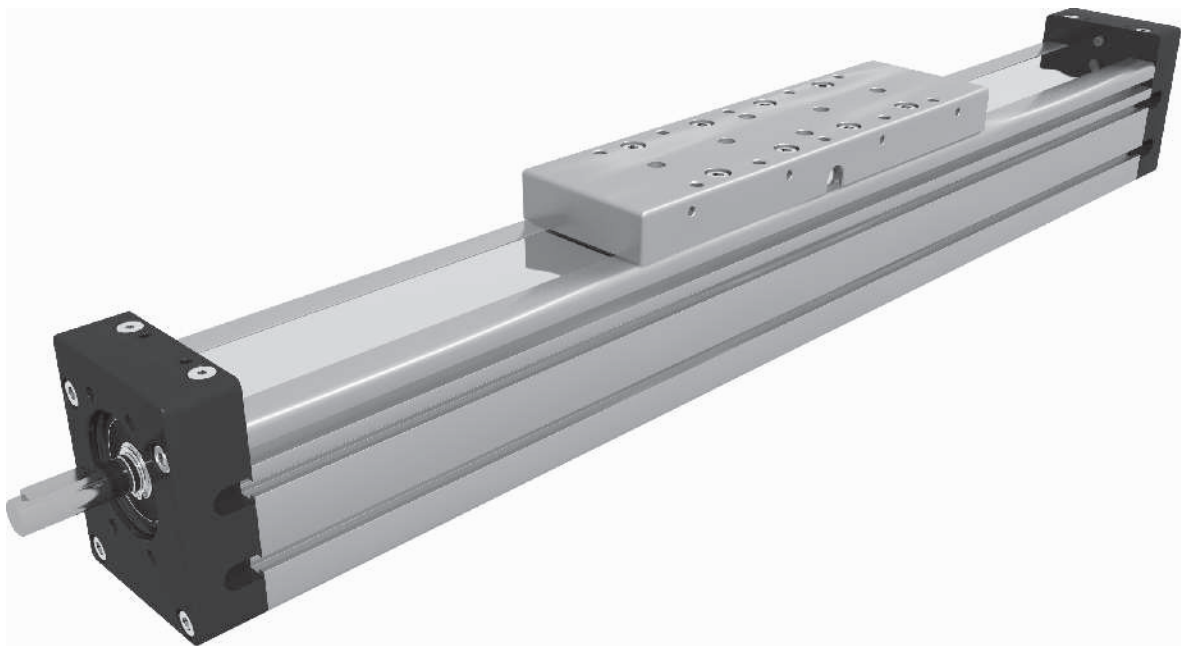

The aluminium profiles are manufactured according to the medium EN 12020-2 standard

Straightness = 0,35 mm/m; Max. torsion = 0,35 mm/m; Angular torsion = 0,2 mm/40 mm; Parallelism = 0,2 mm

STRUCTURAL DESIGN

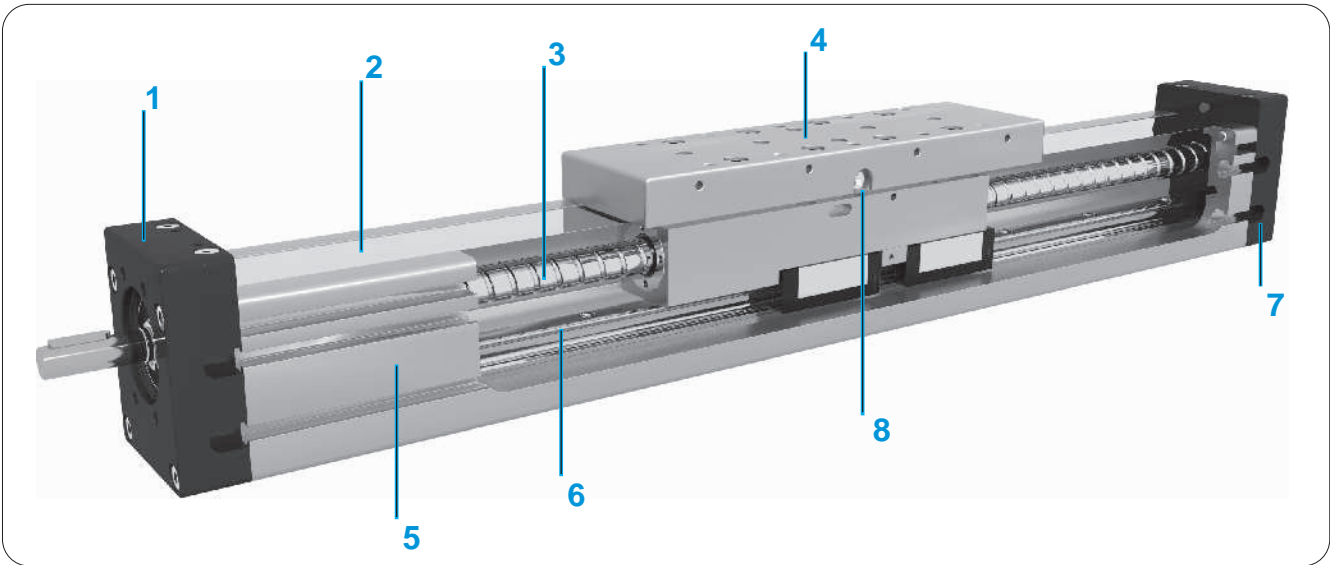

- 1 - Drive block with floating bearing
- 2- Corrosion-resistant protection strip
- 3 - Ball screw tolerance ISO 7 (ISO 5 available on request)
- 4 - Carriage, with built in Magnets
- 5 - Aluminium profile-Hard anodized
- 6 - Integrated Linear Ball Guideway
- 7 - End block with fixed bearing
- 8 - One central lubrication port

HOW TO ORDER

MTV - **65** - **1610** - **ISO7** - **1** - **1000**

Series :

MTV

Size :

65, 80

Ball screw :

MTV 65: Ø16x5, Ø16x10, Ø16x16

MTV 80: Ø20x5, Ø20x10, Ø20x20

Ball screw tolerance :

ISO7 (Standard)

ISO5

Ball screw journal :

0 : Without keyway

1 : With keyway

Absolute stroke (mm) :

TECHNICAL DATA

General technical data for MTV series

Linear Unit	Carriage length Lv [mm]	Load capacity		Dynamic moment			Moved mass [kg]	* Maximum length Lmax [mm]	Planar moment of inertia	
		Dynamic C [N]	Static C0 [N]	Mx [Nm]	My [Nm]	Mz [Nm]			Iy [cm ⁴]	Iz [cm ⁴]
MTV 65	220	13697	19508	136	488	488	1,5	2500	71,0	89,3
MTV 80	290	29934	42362	402	1287	1287	3,0	2500	143,5	204,0

*For lengths over the stated value in the table above, please contact us



Recommended values of loads:

All the data of static and dynamic moments and load capacities stated in the upper table are theoretical without considering any safety factor. The safety factor depends on the application and its requested safety. We recommend a minimum safety factor (fv =5.0)

Modulus of elasticity²

E = 70000 N / mm

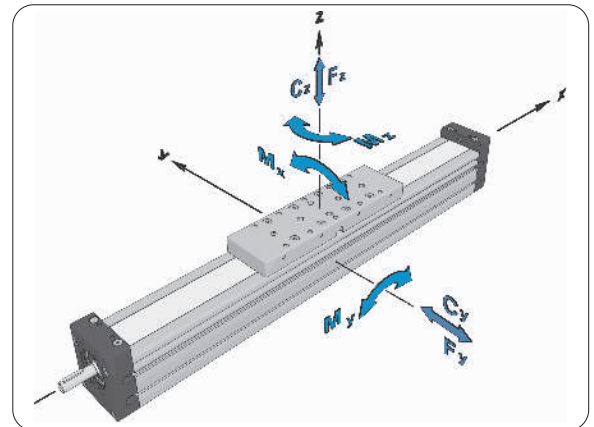

Ball Screw Drive data

Linear Unit	1 Maximal travel speed [m / s]	2 No load torque [Nm]	Lead constant [mm / rev]	Ball Nut type	Ball screw [d x l]	3 Max. repeatability precision [mm]		Dynamic axial load capacity Ca [N]	Maximal drive torque Ma [Nm]
						STANDARD ISO7	ISO5		
MTV 65	$34,2 \cdot 10^{-3} \cdot l / L^2$ [mm]	0,11	5	RSY	16 x 5	± 0,02	± 0,01	7500	6,6
		0,12	10		16 x 10	± 0,02	± 0,01	7020	12,5
		0,13	16		16 x 16	± 0,02	± 0,01	7050	20,0
MTV 80	$44,3 \cdot 10^{-3} \cdot l / L^2$ [mm]	0,16	5	RSY	20 x 5	± 0,02	± 0,01	8700	7,7
		0,17	10		20 x 10	± 0,02	± 0,01	8700	15,5
		0,18	20		20 x 20	± 0,02	± 0,01	7650	27,0

¹For travel speed over the stated value in the table above please contact us.

²The stated values are for strokes up to 500mm. No Load Torque value increases with stroke elongation

³For the ball nut with the preload of 2%, please contact us.



Reduced effective diameter at journal with keyway decreases values of max. drive torque.

Linear Unit	Max. permissible drive torque Mp [Nm]
MTV 65	5,3
MTV 80	11,9

Mass and mass moment of inertia

Linear Unit	Carriage length Lv [mm]	Mass of linear unit	Mass moment of inertia
		[kg]	[10 ⁻⁵ kg·m ²]
MTV 65	220	3,3 + 0,0073 * Stroke [mm]	2,5 + 0,005 * Stroke [mm]
MTV 80	290	8,2 + 0,0114 * Stroke [mm]	8,5 + 0,013 * Stroke [mm]



Mass calculation doesn't include mass of motor, reduction gear, switches and clamps.

DIMENSIONS



Linear Unit doesn't include any safety stroke.

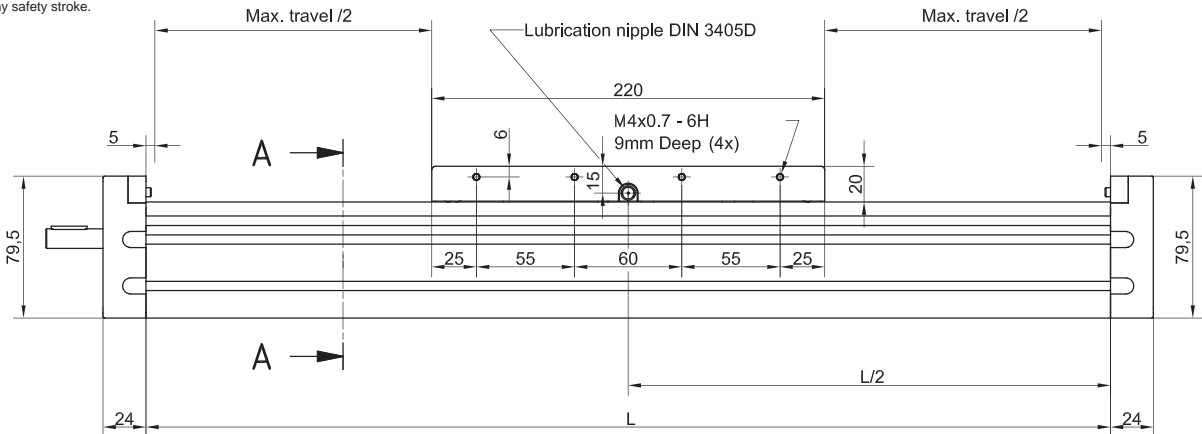

Journal with or without keyway.

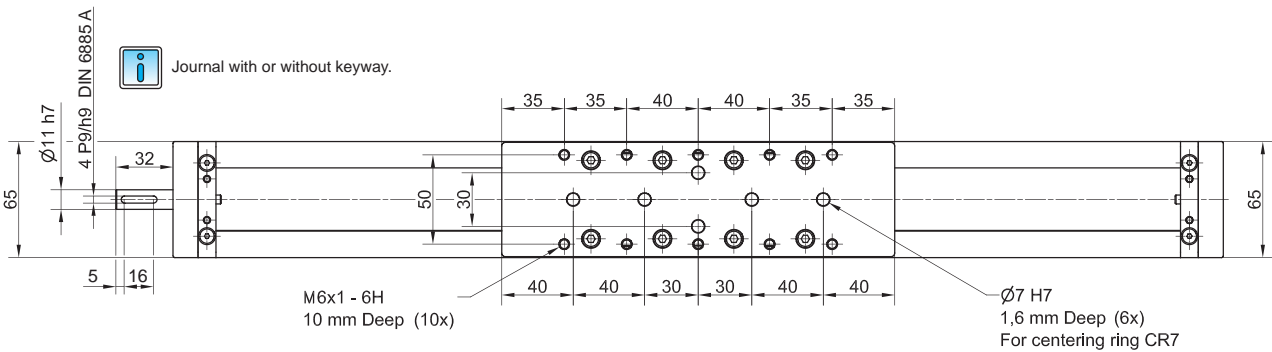

All dimensions in mm;
Drawings scales are not equal.

Defining of the linear module length

$$L = \text{Effective stroke} + 2 \times \text{Safety travel} + L_v + 10 \text{ mm}$$

Left side (L)

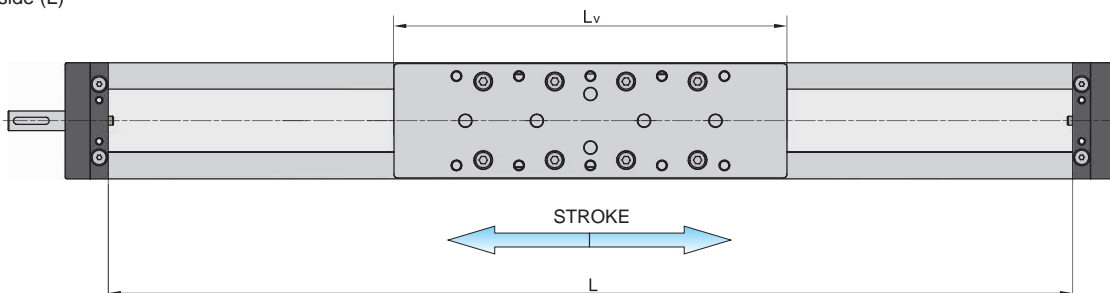

Right side (R)

DIMENSIONS

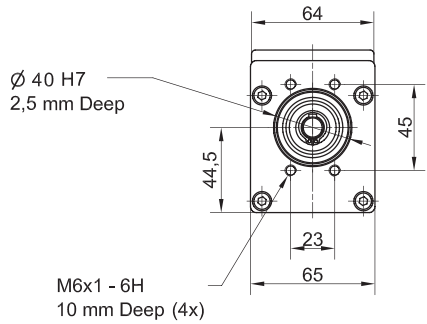

M6x1 - 6H
10 mm Deep (4x)

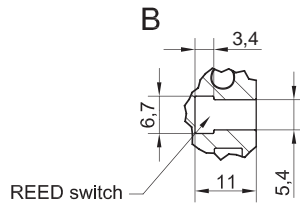
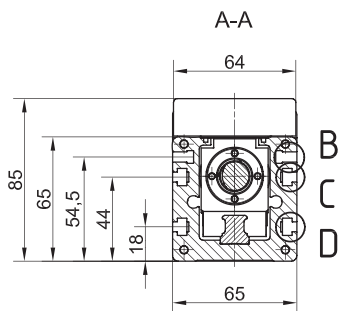

REED switch

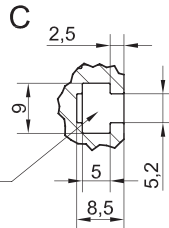

DIN 557 - M5

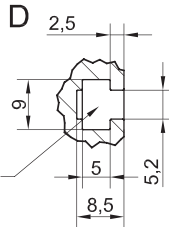

DIN 557 - M5

All dimensions in mm;
Drawings scales are not equal.

CENTERING RING CR7
Material: 1.4305 (AISI303)

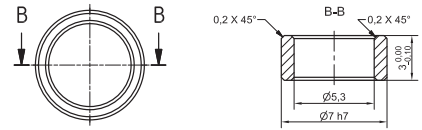

TAP / PIN holes on the bottom of the profile available on request.

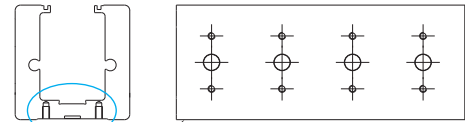

TAP / PIN holes on the bottom of the profile

Drawing only for presentational use.

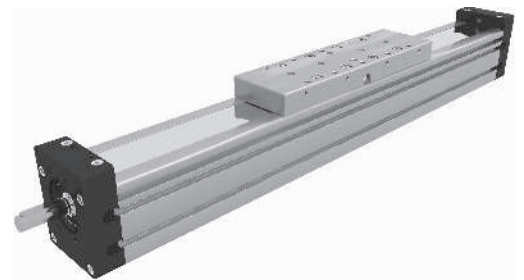

MOTOR - MOTOR SIDE DRIVE

Available on request

MOTOR

Available on request

GEAR REDUCER + MOTOR

Available on request

GEAR REDUCER 90° + MOTOR

Available on request

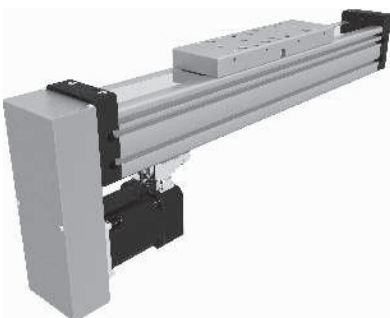

For more info about MSD please refer to page 6.045.0

DIMENSIONS

 Linear Unit doesn't include any safety stroke.

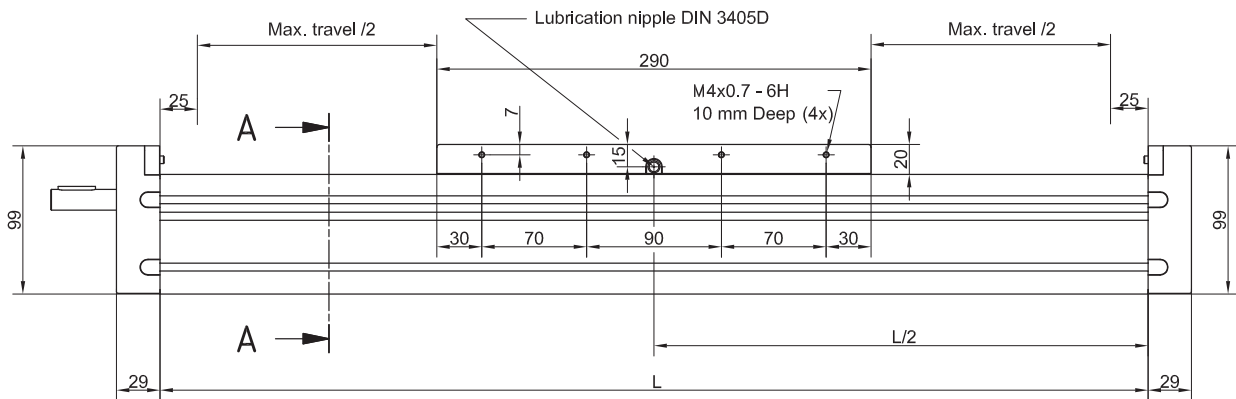

 Journal with or without keyway.

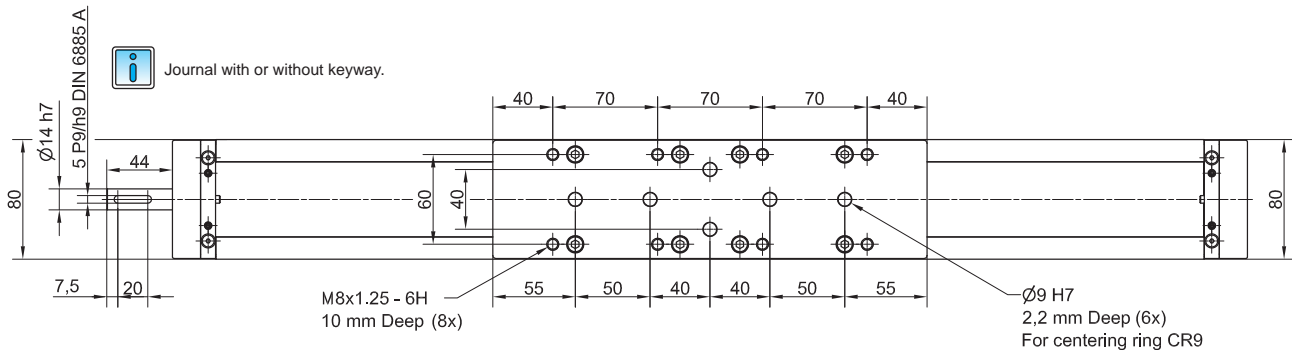

 All dimensions in mm.; Drawings scales are not equal.

Defining of the linear module length

$L = \text{Effective stroke} + 2 \times \text{Safety travel} + L_v + 50 \text{ mm}$

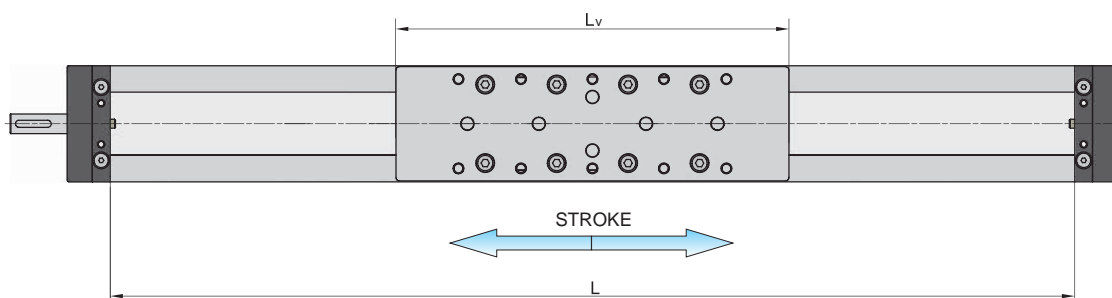

DIMENSIONS

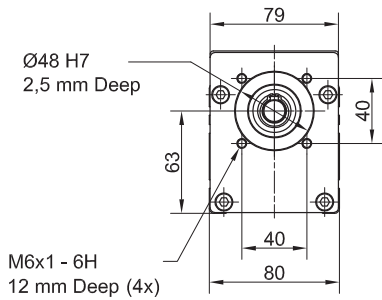

M6x1 - 6H
12 mm Deep (4x)

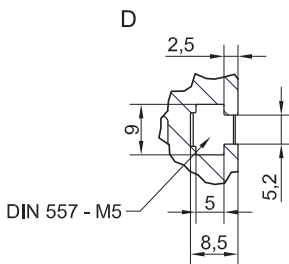
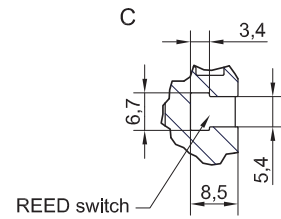
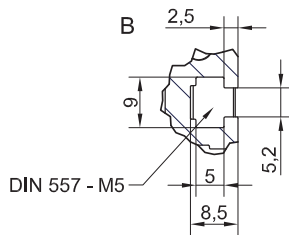
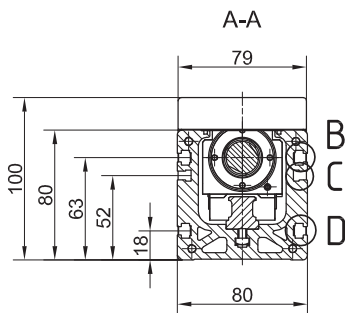

All dimensions in mm;
Drawings scales are not equal.

CENTERING RING CR9
Material: 1.4305 (AISI303)

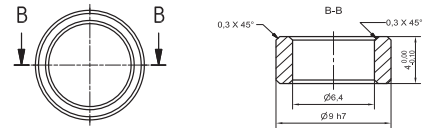

i TAP / PIN holes on the bottom of the profile available on request.

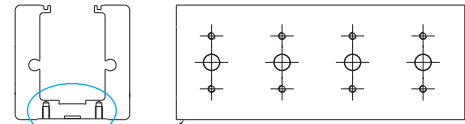

i Drawing only for presentational use.

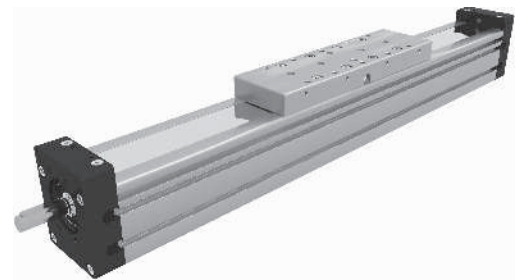

MOTOR - MOTOR SIDE DRIVE

MTV 80

Available on request

MOTOR

MTV 80

Available on request

GEAR REDUCER + MOTOR

MTV 80

Available on request

GEAR REDUCER 90° + MOTOR

MTV 80

Available on request

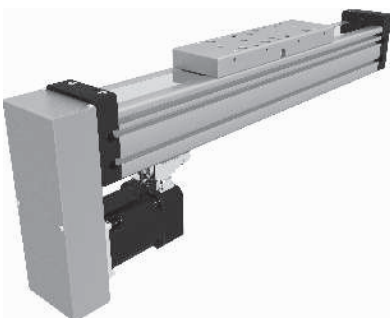

For more info about MSD, please refer to page 6.045.0

CHARACTERISTICS

The **MTJ ECO** series Linear Unit is a powerful and cost-effective Linear Unit with toothed belt drive and a Zero-backlash Ball rail guide system for easy and accurate linear movements.

It can easily be combined to multi-axis systems.

Excellent price-/performance ratio and quick delivery time are ensured.

An extruded aluminum Profile from 6063 AL with on it mounted Zero-backlash Ball rail guide system, allows high load capacities and optimal cycles for the movement of larger masses at high speed.

The linear unit MTJ ECO uses a pre-tensioned steel reinforced AT polyurethane timing toothed belt. In conjunction with a Zero-backlash drive pulley high moments with alternating loads with good positioning accuracy, low wear and low noise can be realized.

The aluminum Profile includes T-slots for fixing the Linear Unit and for attaching sensors and switches . Different carriage lengths of the Linear Unit allow the possibility to attach additional accessories on the side.

Lubrication holes on the carriage allow easy re-lubrication of the Ball rail guide .

For the linear unit MTJ ECO various adaptation options, for attaching (or redirecting), for Motors or Gearboxes are available.

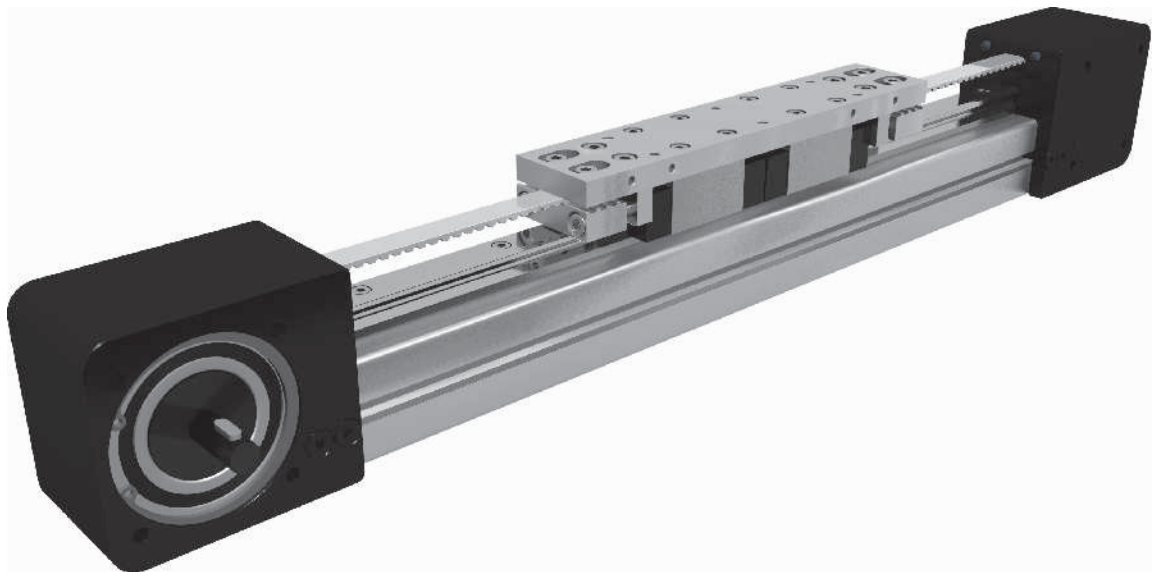

The aluminium profiles are manufactured according to the medium EN 12020-2 standard

Straightness = 0,35 mm/m; Max. torsion = 0,35 mm/m; Angular torsion = 0,2 mm/40 mm; Parallelism = 0,2 mm

STRUCTURAL DESIGN

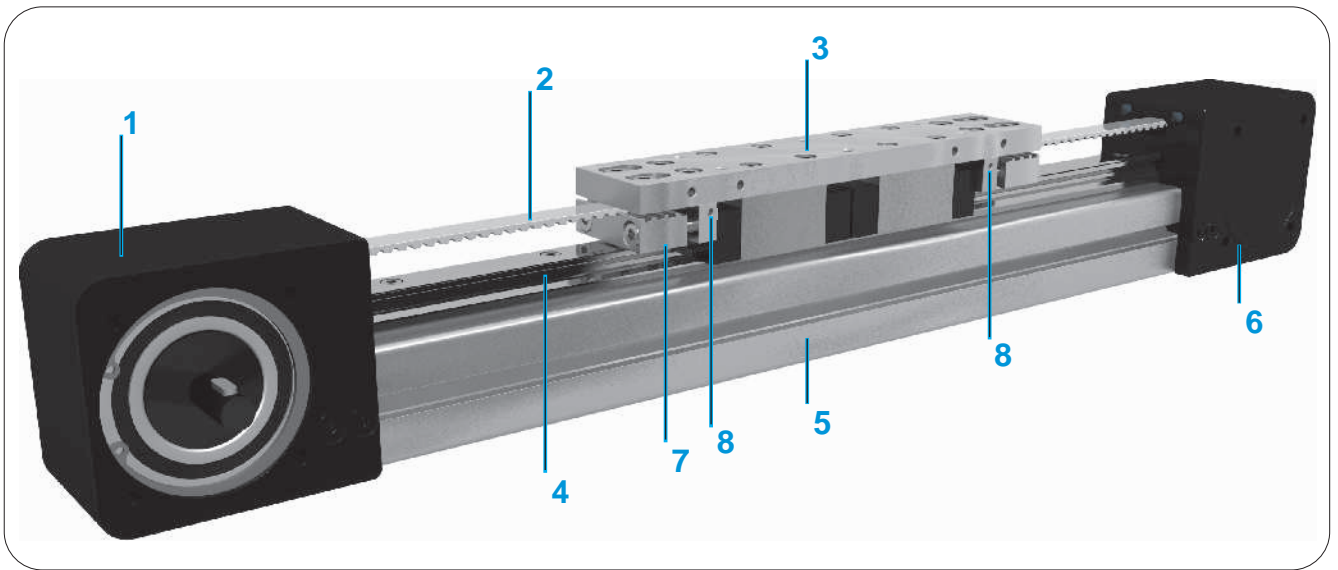

- 1 - Drive block with pulley
- 2 - AT polyurethane toothed belt with steel tension cords
- 3 - Carriage
- 4 - Linear Ball Guideway
- 5 - Aluminium profile-Hard anodized
- 6 - End block
- 7 - Belt Tension system
- 8 - Lubrication port

HOW TO ORDER

MTJ ECO - **40** - **1000** - **L** - **1** - **R**

Series :

MTJ ECO

Size :

40

Absolute stroke (mm) :

Carriage Version :

S : Short

L : Long

Type of drive pulley :

0 : Pulley with through hole

1 : Pulley with journal

10 : Pulley with journal (without Keyway)

2 : Pulley with journal on both sides

20 : Pulley with journal on both sides (without Keyway)

3 : Without drive unit

Drive journal position :

L : Journal on left side

R : Journal on right side

Without : For type of drive pulley 0, 2 and 3

TECHNICAL DATA

General technical data for MTJ ECO series

Linear Unit	Carriage length Lv [mm]	Load capacity		Dynamic moment			Moved mass [kg]	Maximum Repeatability [mm]	* Maximum length Lmax [mm]	Planar moment of inertia	
		Dynamic C [N]	Static C0 [N]	Mx [Nm]	My [Nm]	Mz [Nm]				Iy [cm ⁴]	Iz [cm ⁴]
MTJ ECO 40 S	132	9329	19629	64	55	55	0,45	± 0,1	5960	9,53	9,21
MTJ ECO 40 L	200	18658	39258	128	620	620	0,72	± 0,1			

*For lengths over the stated value in the table above, please contact us.

Recommended values of loads

All the data of static and dynamic moments and load capacities stated in the upper table are theoretical without considering any safety factor. The safety factor depends on the application and its requested safety. We recommend a minimum safety factor (fv =5.0)

Modulus of elasticity²

E = 70000 N / mm

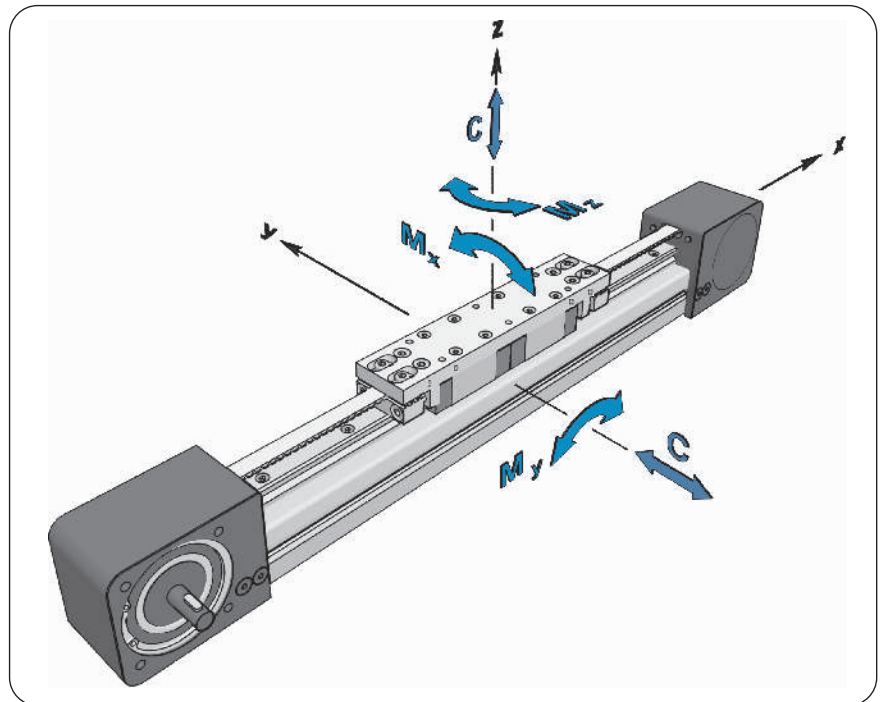

Drive and belt data

Linear Unit	Maximal travel speed [m / s]	Maximum drive torque [Nm]	* No load torque [Nm]	Puley drive ratio [mm / rev]	Pulley diameter [mm]	Belt type	Belt width [mm]	Max. force transmitted by belt [N]	Limit of belt elasticity [N]	Specific spring constant Cspec [N]
MTJ ECO 40 S	3	7,5	0,8	180	57,31	AT5	12	262	940	235 000
MTJ ECO 40 L			0,9							

*The stated values are for strokes up to 500mm. No Load Torque value increases with stroke elongation

Mass and mass moment of inertia

Linear Unit	Carriage length Lv [mm]	Mass of linear unit [kg]	Mass moment of inertia [10 ⁻⁵ kg·m ²]
MTJ ECO 40 S	132	3,1 + 0,003 * Stroke [mm]	70,1 + 0,007 * Stroke [mm]
MTJ ECO 40 L	200	3,55 + 0,003 * Stroke [mm]	92,3 + 0,007 * Stroke [mm]

Mass calculation doesn't include mass of motor, reduction gear, switches and clamps.

DIMENSIONS

Linear Unit doesn't include any safety stroke.

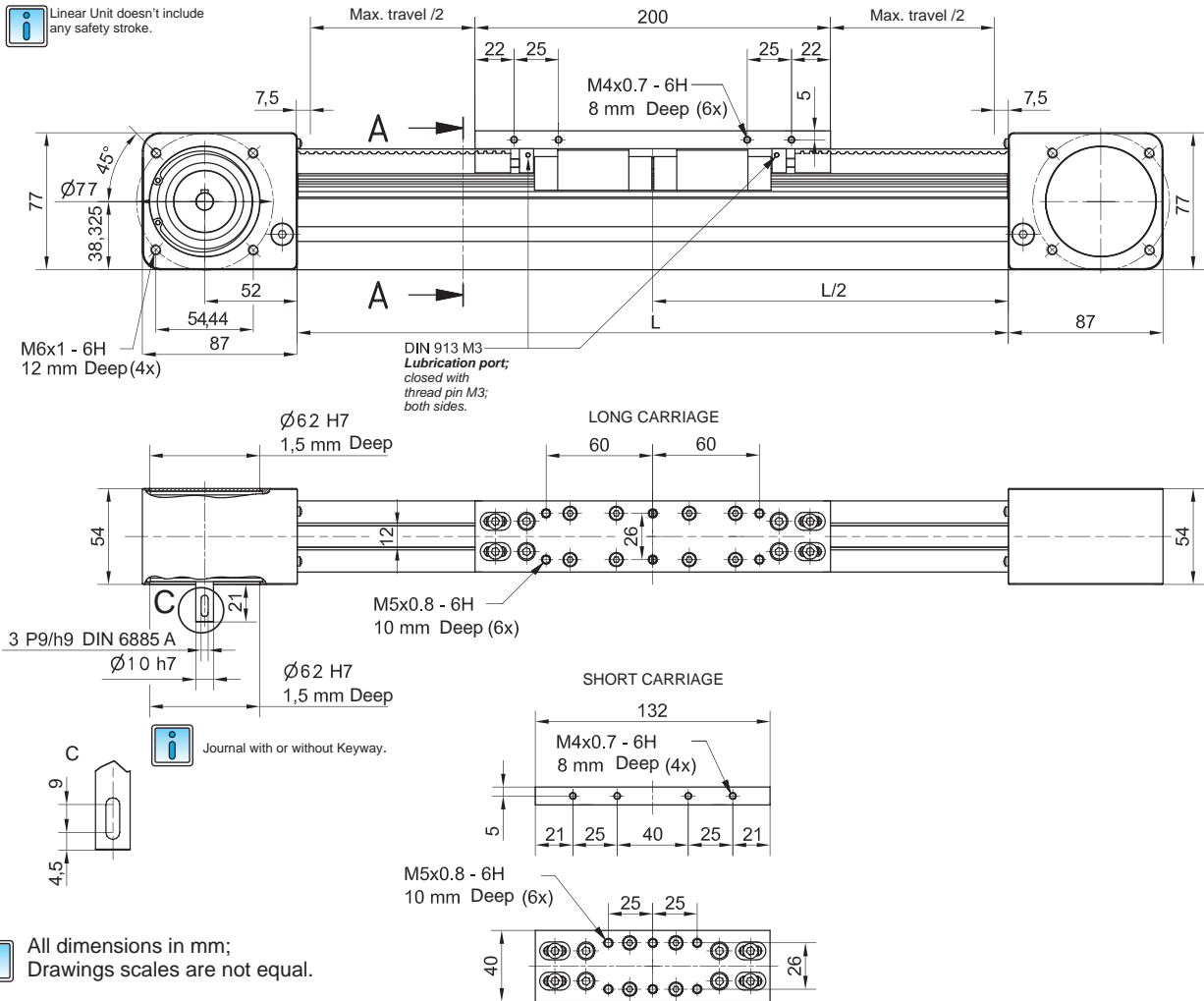

TYPE 0

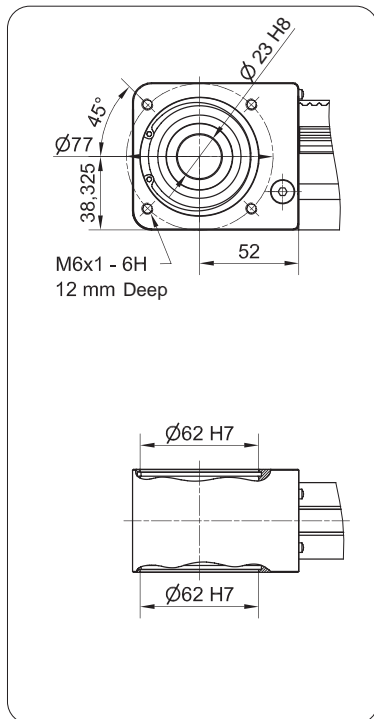

TYPE 1 L and 1 R

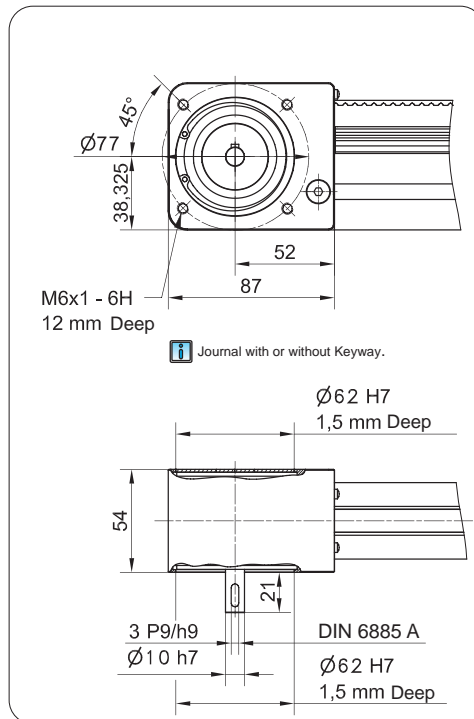

TYPE 2

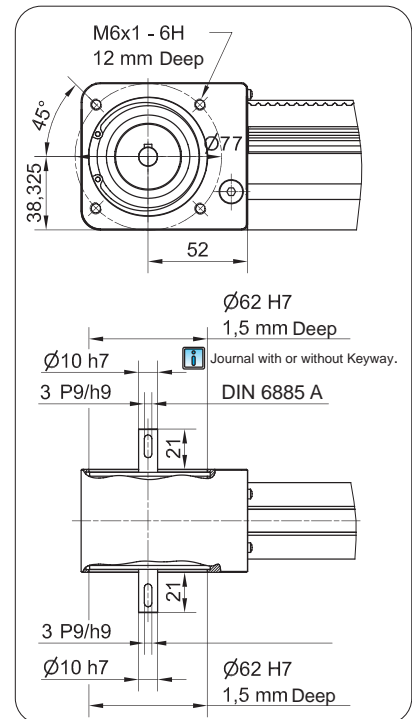

TECHNICAL DATA

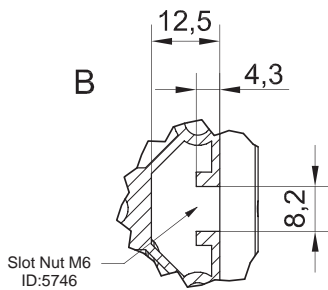
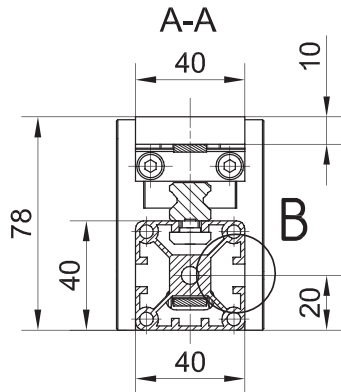

All dimensions in mm;
Drawings scales are not equal.

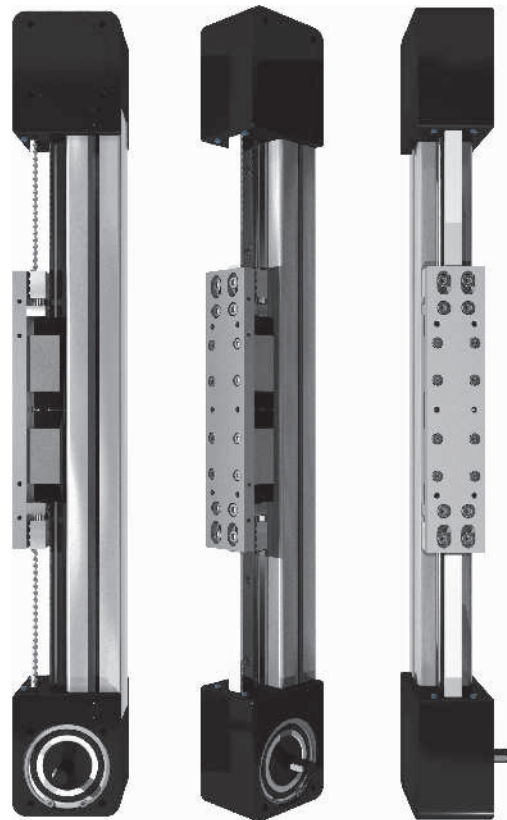

MOTOR

MTJ 40 ECO

Available on request

GEAR REDUCER + MOTOR

MTJ 40 ECO

Available on request

GEAR REDUC. 90° + MOTOR

MTJ 40 ECO

Available on request

Defining of the linear module length

$L = \text{Effective stroke} + 2 \times \text{Safety travel} + L_v + 15 \text{ mm}$

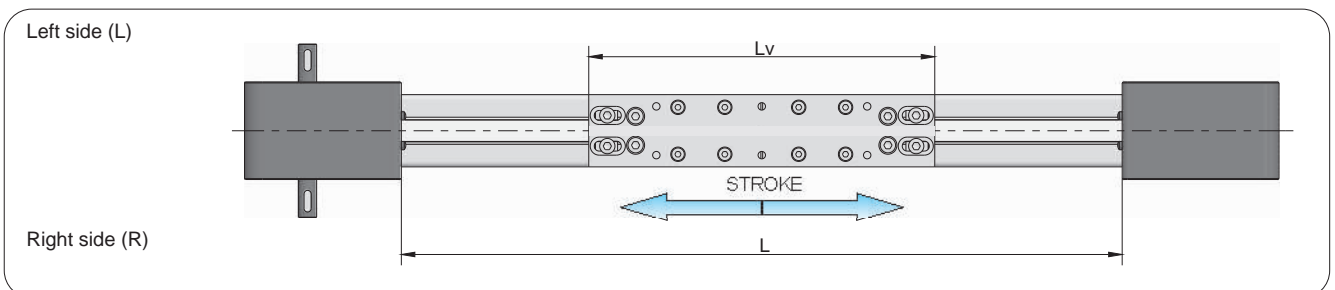

Double Carriage

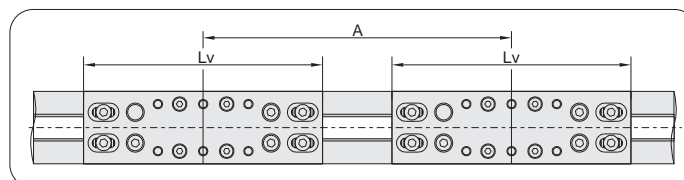

For ordering code please contact us.

$L = \text{Effective stroke} + 2 \times \text{Safety travel} + L_v + A + 15 \text{ mm}$ } $A \geq L_v$

CHARACTERISTICS

The **MTJZ** series contains Z-axis Linear Units with toothed belt drive , integrated Ball rail system and compact dimensions. This Linear Units provide high performance features such as, high speed, good accuracy and repeatability by vertical applications.

They can easily be combined to multi-axis systems.

Excellent price-/performance ratio and quick delivery time are ensured.

The compact, precision-extruded aluminum Profile from 6063 AL with integrated Zero-backlash Ball rail guide system, allows high load capacities and optimal cycles for the movement of larger masses at high speed.

In the linear units MTJZ is used a pre-tensioned steel reinforced AT polyurethane timing toothed belt. In conjunction with a Zero-backlash drive pulley high moments with alternating loads with good positioning accuracy, low wear and low noise can be realized.

The in the Profile slot driving Polyurethane timing belt protects all the parts in the Profile from dust and other contaminations

The aluminum Profile includes T-slots for attaching sensors and switches. Also, a Reed switch can be used here.

The drive block provides the possibility to attach a Motor or Gearbox housing and additional accessories on it.

Central lubrication port on the drive block allows easy re-lubrication of the Ball rail guide.

For the linear units MTJZ various adaptation options, for attaching (or redirecting), for Motors or Gearboxes are available.

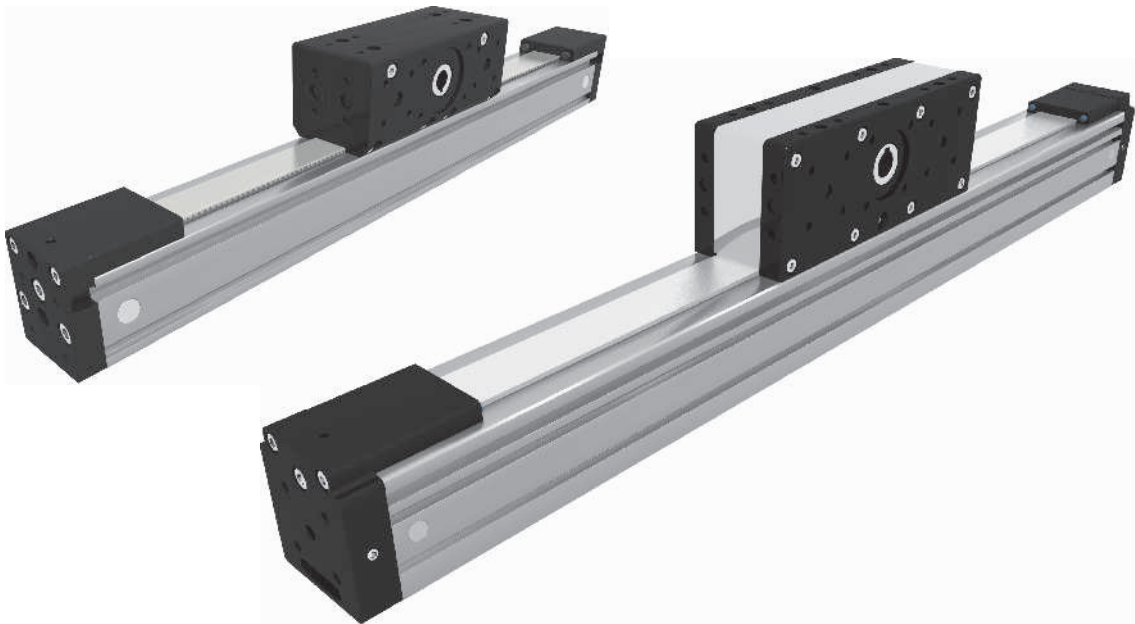

The aluminium profiles are manufactured according to the medium EN 12020-2 standard

Straightness = 0,35 mm/m; Max. torsion = 0,35 mm/m; Angular torsion = 0,2 mm/40 mm; Parallelism = 0,2 mm

STRUCTURAL DESIGN

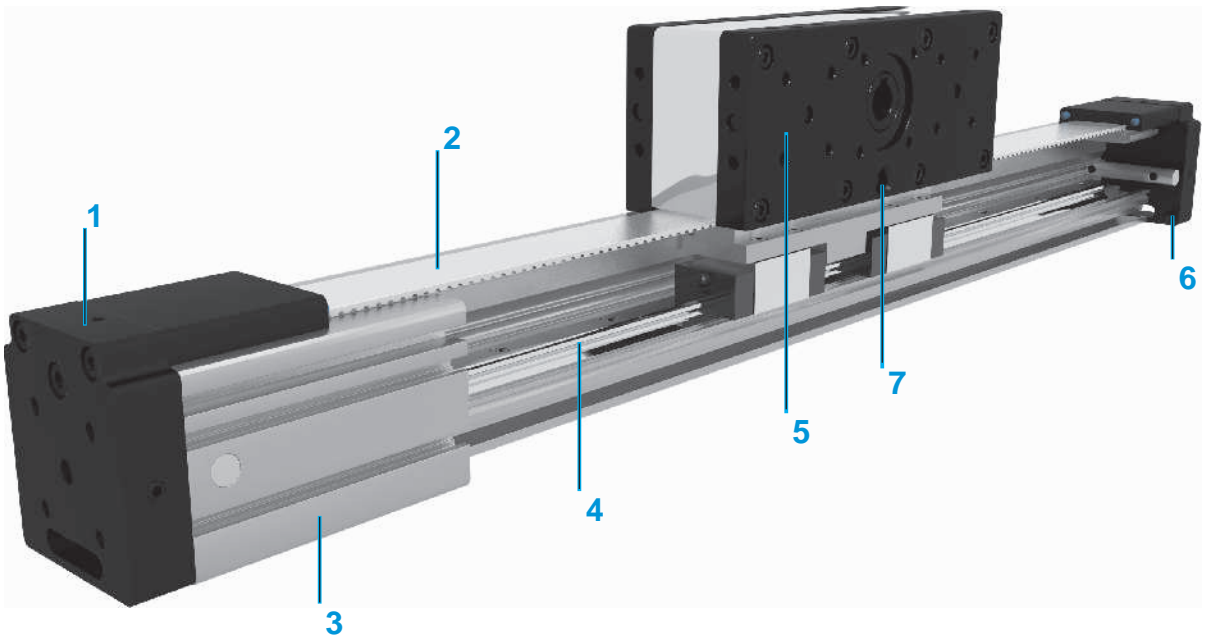

- 1 - Tension End with integrated belt tensionin system
- 2 - AT polyurethane toothed belt with steel tension cords.
- 3 - Aluminium profile-Hard anodized
- 4 - Linear Ball Guideway
- 5 - Drive block with pulley, Motor flange; with built in Magnets
- 6 - Tension End with integrated belt tensionin system
- 7 - Central lubrication port

HOW TO ORDER

MTJZ - 65 - 1000 - 1

Series :

MTJZ

Size :

40

65

80

Absolute Stroke (mm):

Type of drive pulley :

0 : Pulley with through hole

1 : Pulley with journal

10 : Pulley with journal (without Keyway)

2 : Pulley with journal on both sides

20 : Pulley with journal on both sides (without Keyway)

TECHNICAL DATA

General technical data for MTJZ series

Linear Unit	Drive block length Lv [mm]	Load capacity		Dynamic moment			Mass of drive block [kg]	Maximum Repeatability [mm]	* Maximum length Lmax [mm]	Planar moment of inertia	
		Dynamic C [N]	Static C0 [N]	Mx [Nm]	My [Nm]	Mz [Nm]				Iy [cm ⁴]	Iz [cm ⁴]
MTJZ 40	120	4616	6930	28,6	120	120	0,95	± 0,08	1000	9,8	11,6
MTJZ 65	200	13697	19508	136	712	712	3,2	± 0,08	1200	59,8	73,8
MTJZ 80	250	29933	42362	402	2245	2245	4,9	± 0,08	1500	129,4	173,5

*For lengths over the stated value in the table above please contact us.



Recommended values of loads

All the data of static and dynamic moments and load capacities stated in the upper table are theoretical without considering any safety factor. The safety factor depends on the application and its requested safety. We recommend a minimum safety factor (fv =5.0)

Modulus of elasticity²

E = 70000 N / mm

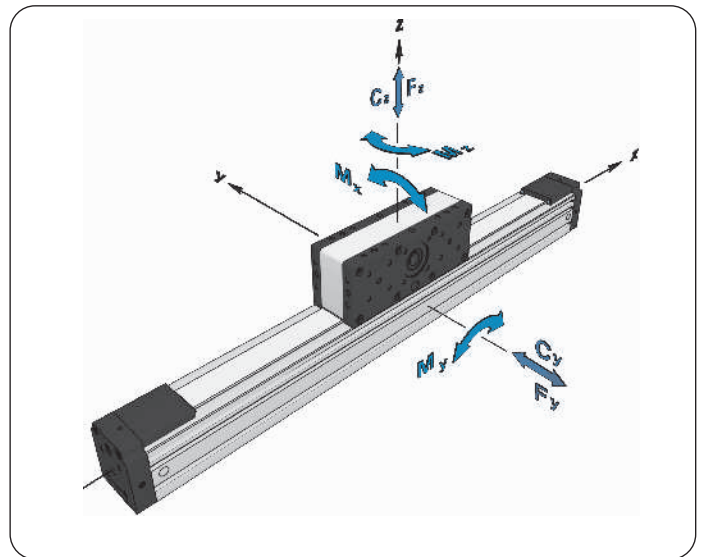

Drive and belt data

Linear Unit	Maximum travel speed [m / s]	Maximum drive torque [Nm]	Puley drive ratio [mm / rev]	Pulley diameter [mm]	Belt type	Belt width [mm]	Max. force transmitted by belt [N]	Limit of belt elasticity [N]	Specific spring constant Cspec [N]·
MTJZ 40	6	3,6	99	31,51	AT3	20	230	900	225000
MTJZ 65	6	13,1	165	52,52	AT5	32	500	2400	600000
MTJZ 80	6	29,4	210	66,84	AT5	50	880	3840	960000

Mass and mass moment of inertia

Linear Unit	Mass of linear unit [kg]	Mass moment of inertia of drive block [10 ⁻⁴ kg·m ²]
MTJZ 40	1,65 + 0,0023 * Stroke [mm]	2,2 + 0,0058 * Stroke [mm]
MTJZ 65	5,3 + 0,0054 * Stroke [mm]	19,1 + 0,0374 * Stroke [mm]
MTJZ 80	9,1 + 0,0083 * Stroke [mm]	63,2 + 0,0922 * Stroke [mm]



Mass calculation doesn't include mass of motor, reduction gear, switches and clamps.

DIMENSIONS



Linear Unit doesn't include any safety stroke.

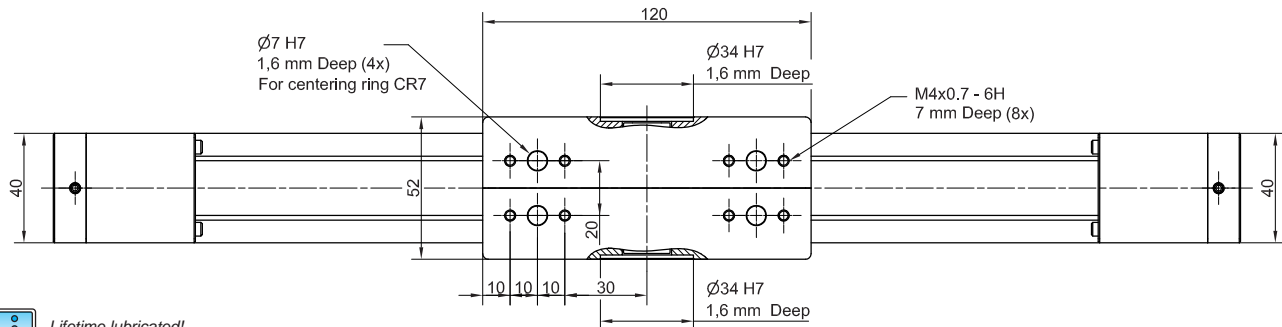
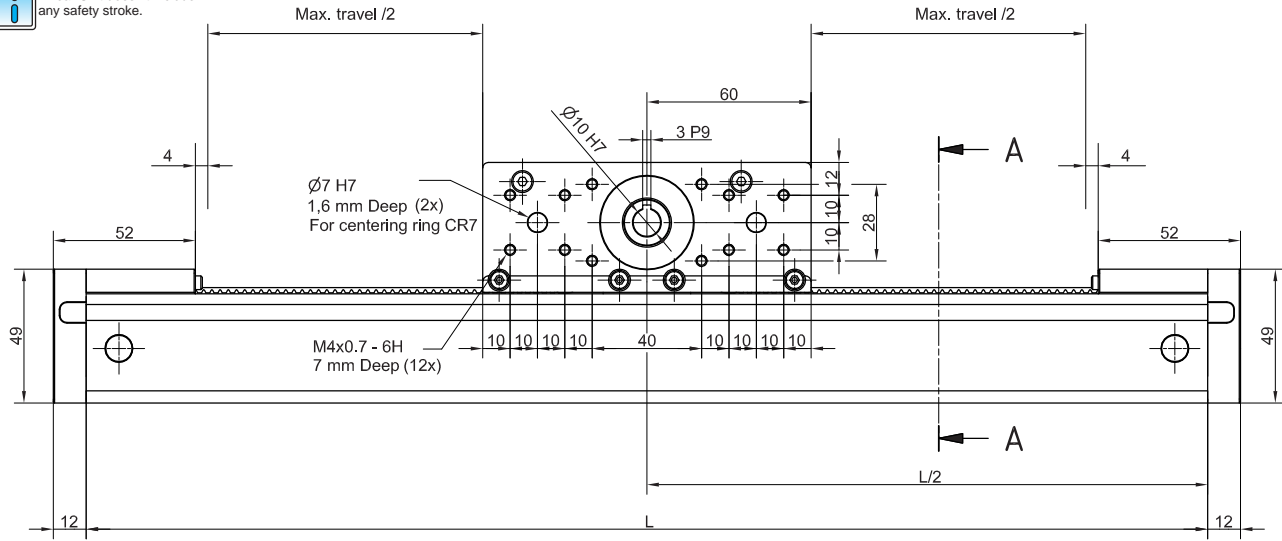

Lifetime lubricated!



All dimensions in mm; Drawings scales are not equal.

TYPE 0

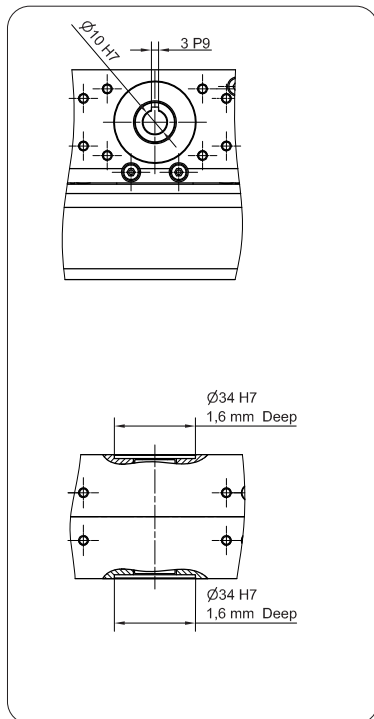

TYPE 1

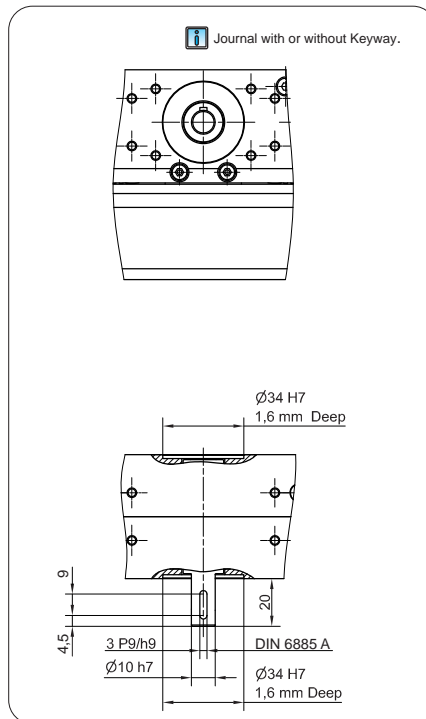

TYPE 2

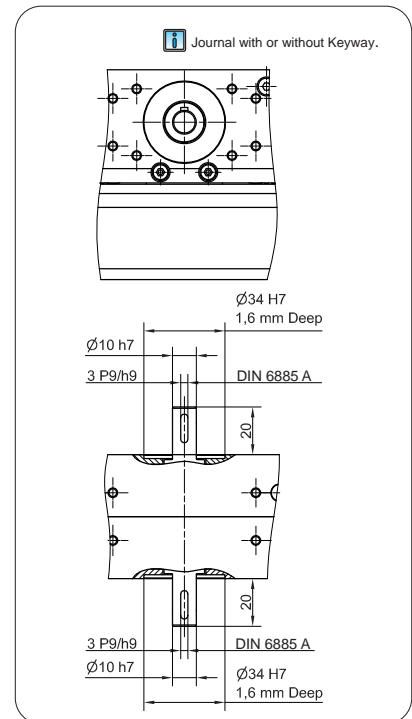

DIMENSIONS

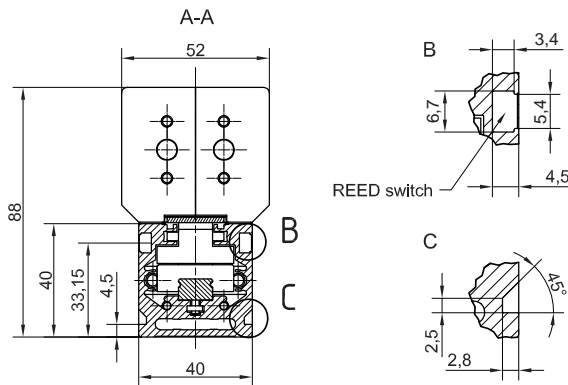
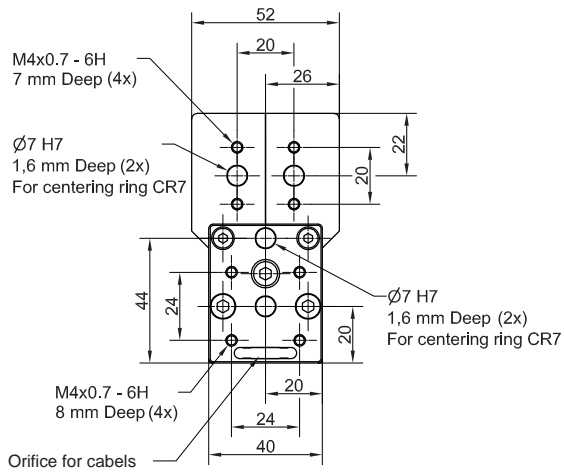

All dimensions in mm; Drawings scales are not equal.

CENTERING RING CR7
Material: 1.4305 (AISI303)

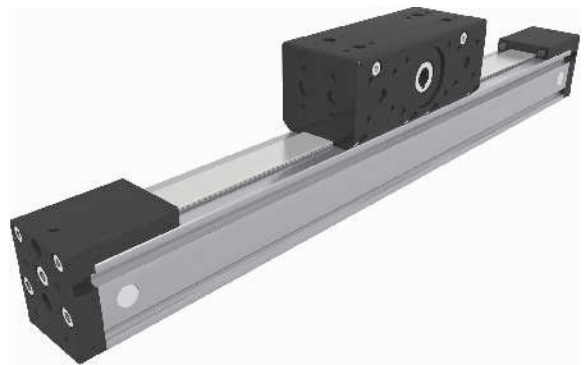
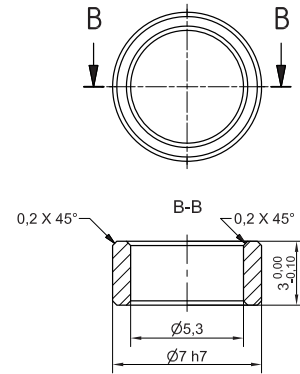

Defining of the linear module length

$L = \text{Effective stroke} + 2 \times \text{Safety travel} + 208 \text{ mm}$

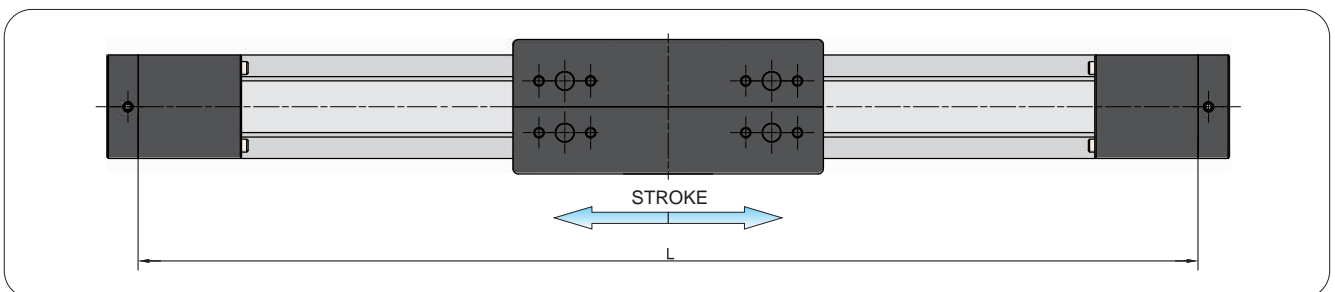

MOTOR

MTJZ 40

Available on request

GEAR REDUCER + MOTOR

MTJZ 40

Available on request

GEAR REDUCER 90° + MOTOR

MTJZ 40

Available on request

DIMENSIONS



Linear Unit doesn't include any safety stroke.

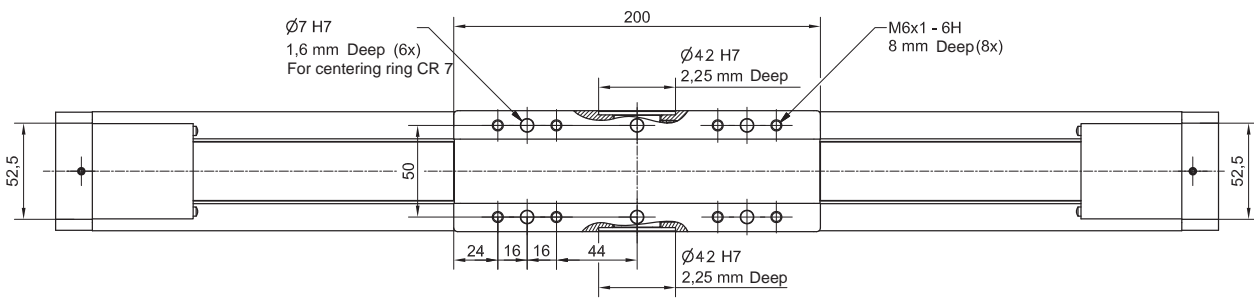
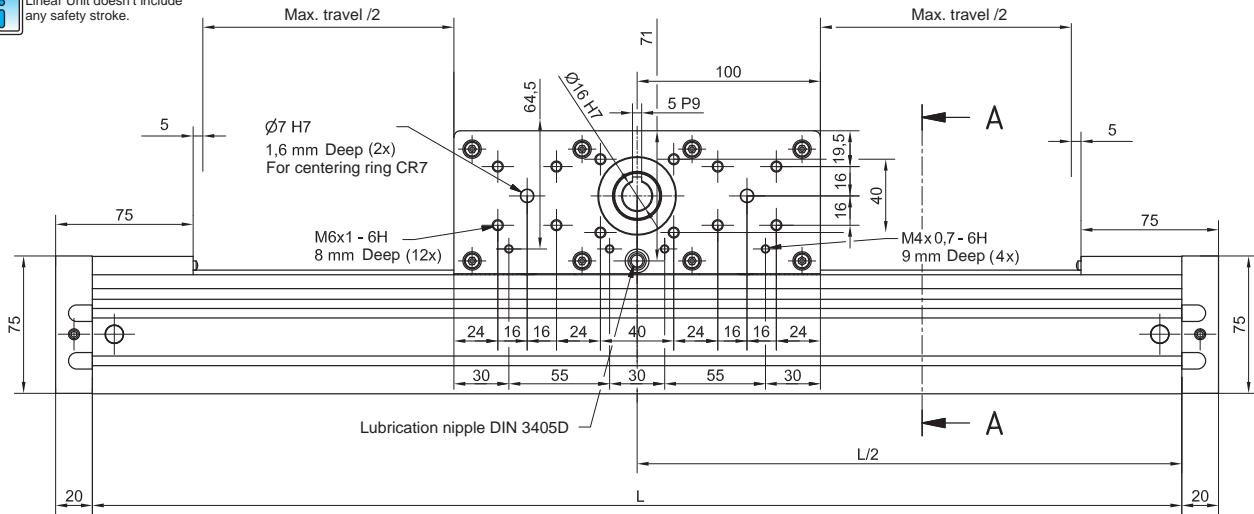

All dimensions in mm; Drawings scales are not equal.

TYPE 0

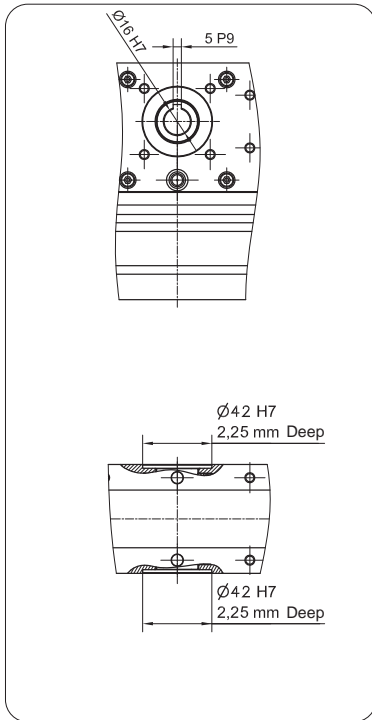

TYPE 1

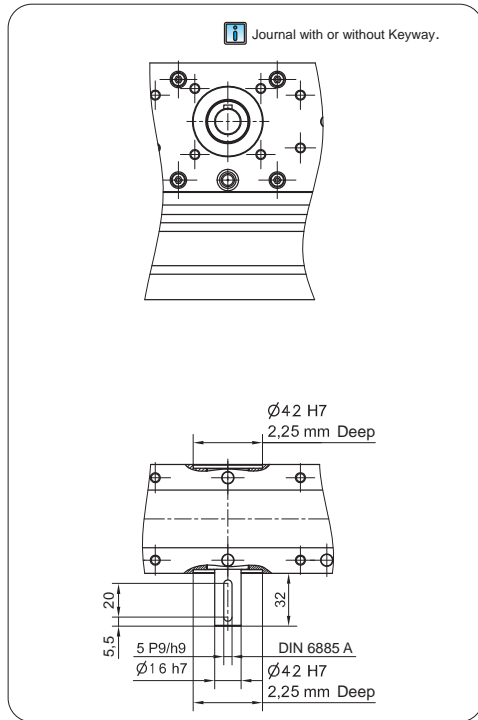

TYPE 2

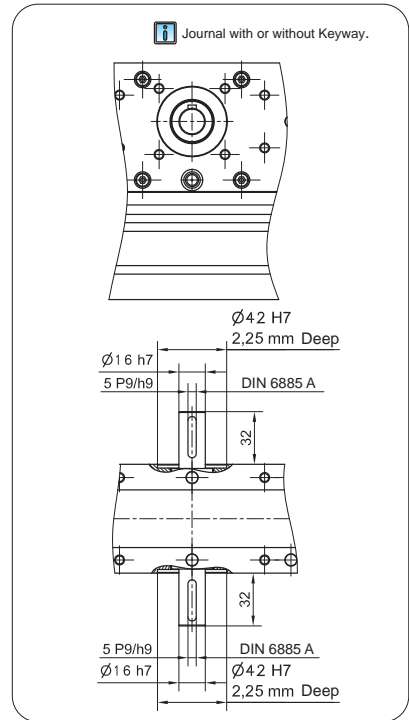

DIMENSIONS

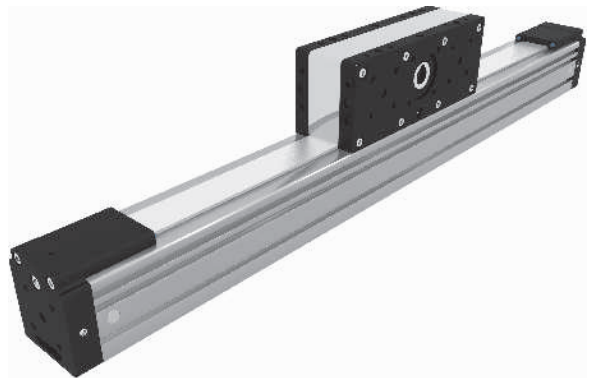
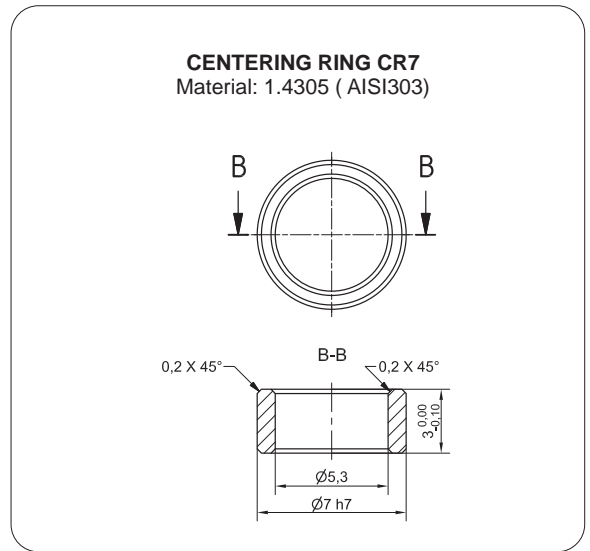
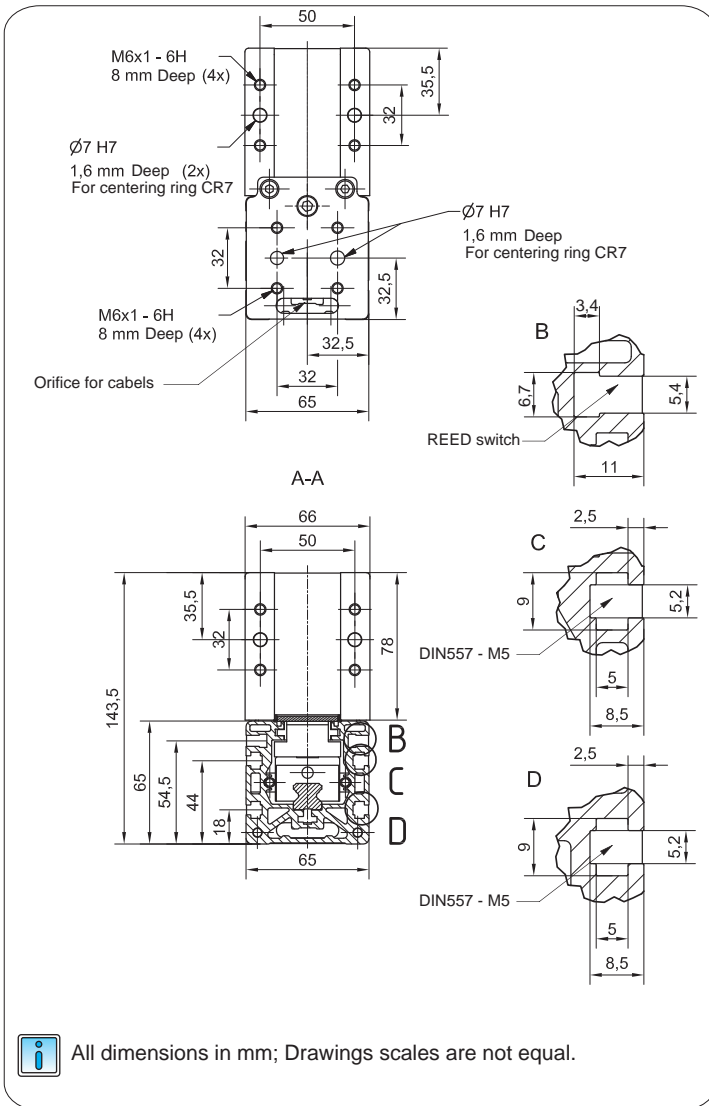

Defining of the linear module length

$$L = \text{Effective stroke} + 2 \times \text{Safety travel} + 320 \text{ mm}$$

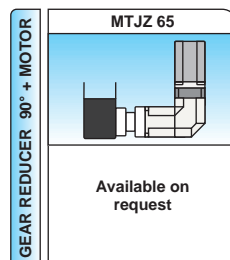
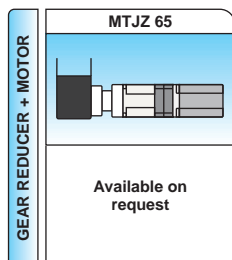
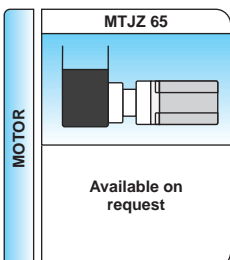
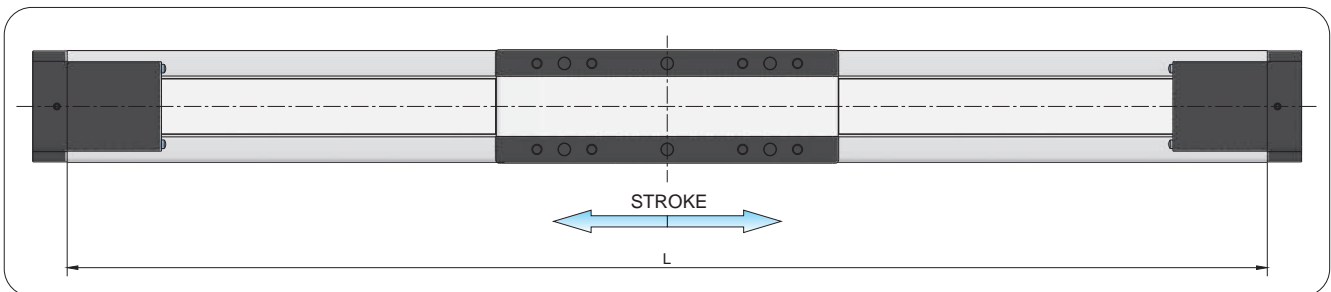

DIMENSIONS



Linear Unit doesn't include any safety stroke.

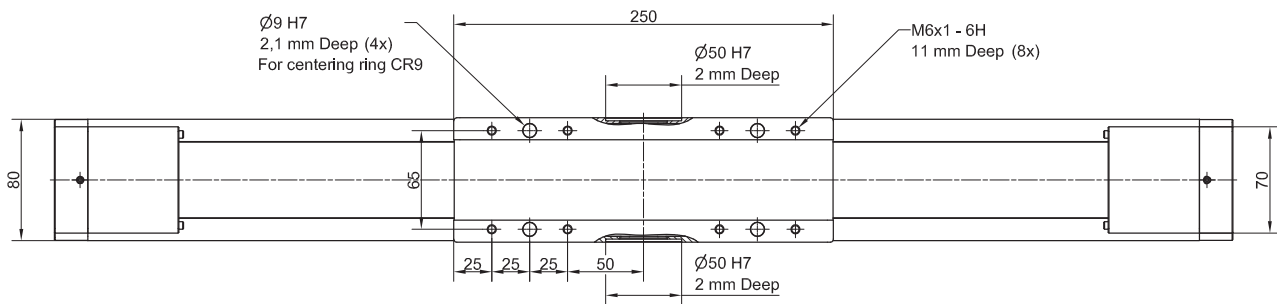
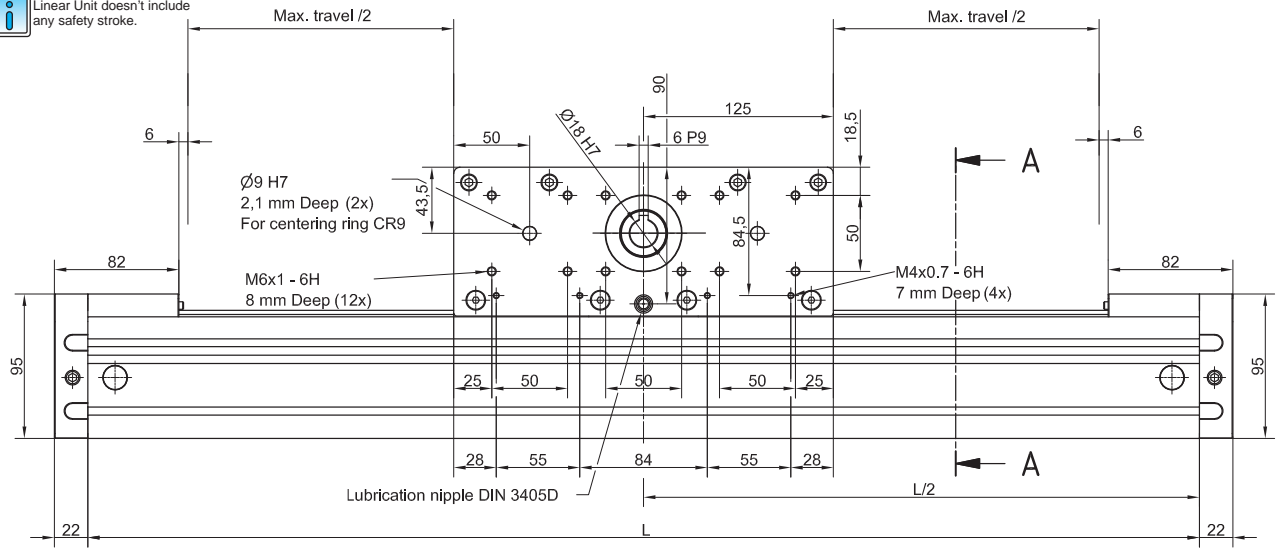

All dimensions in mm; Drawings scales are not equal.

TYPE 0

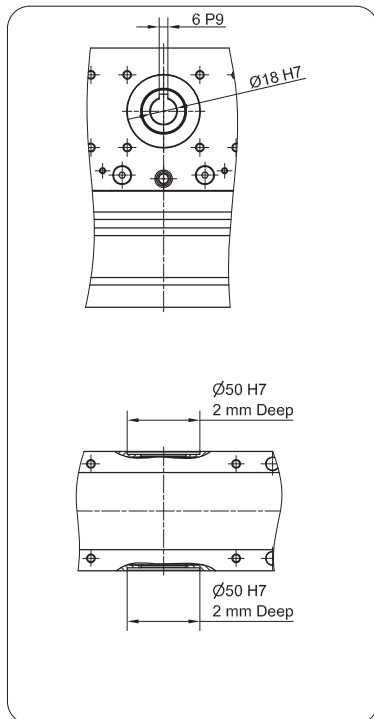

TYPE 1

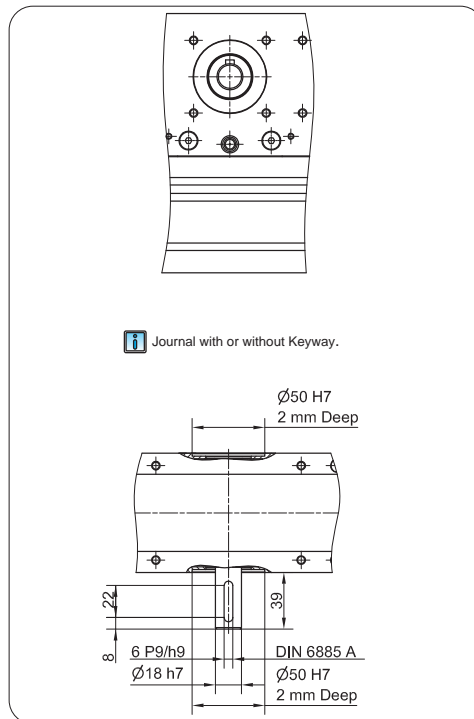

TYPE 2

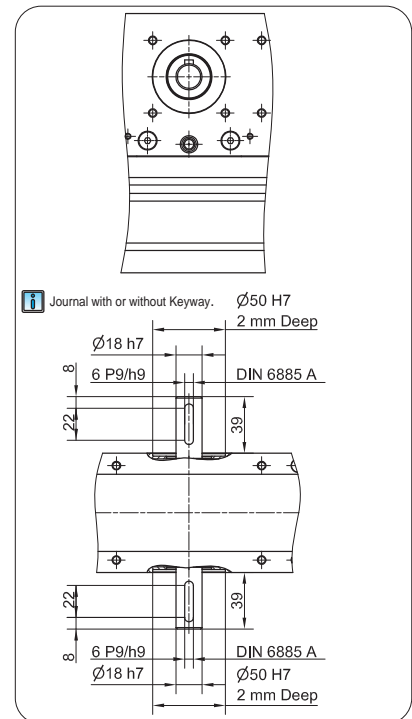

DIMENSIONS

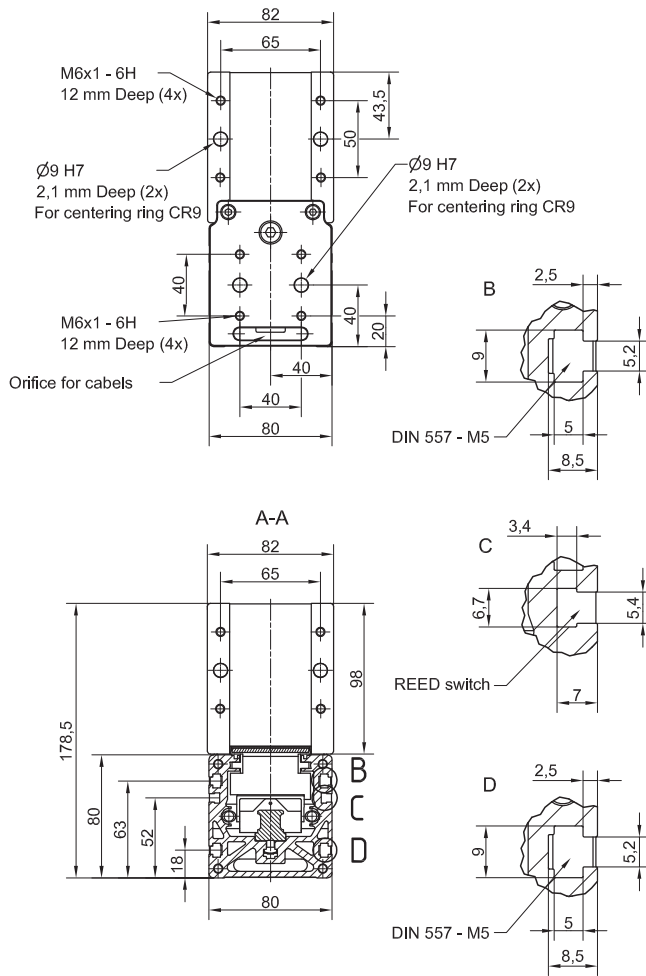

CENTERING RING CR9
Material: 1.4305 (AISI303)

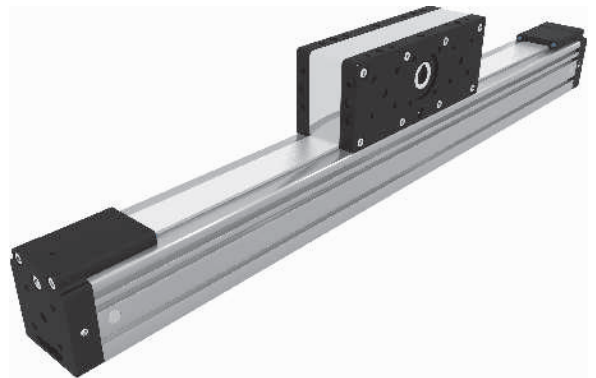
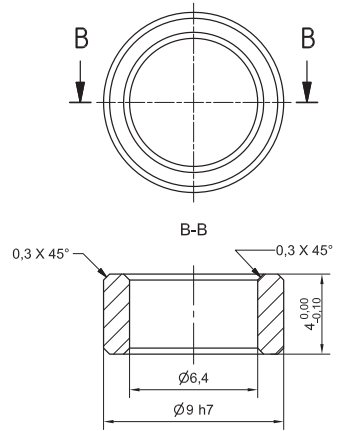

 All dimensions in mm; Drawings scales are not equal.

Defining of the linear module length

$L = \text{Effective stroke} + 2 \times \text{Safety travel} + 382 \text{ mm}$

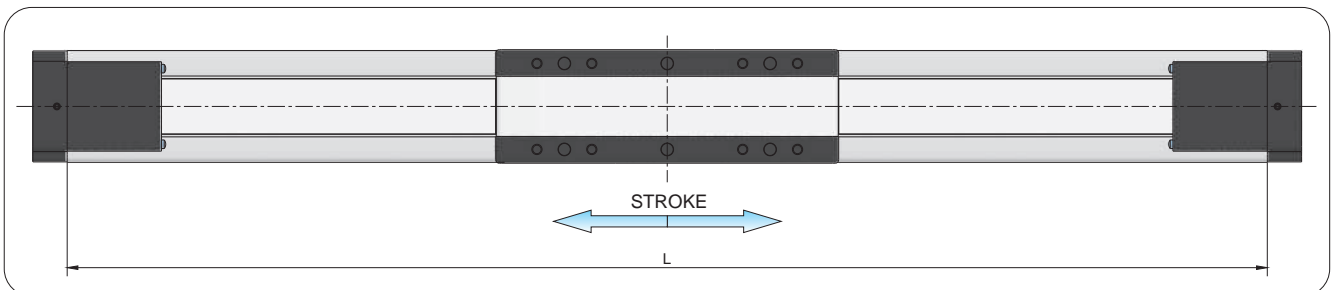

MTJZ 80

MOTOR

Available on request

MTJZ 80

GEAR REDUCER + MOTOR

Available on request

MTJZ 80

GEAR REDUCER 90° + MOTOR

Available on request

CHARACTERISTICS

The **CTJ** series includes Linear Units with a toothed belt drive and two parallel, integrated, Zero-backlash rail guides. Compact dimensions allow high performance features such as, high speed and repeatability. They can easily be combined to multi-axis systems.

Excellent price-/performance ratio and quick delivery time are ensured.

A compact, precision-extruded aluminum Profile from AL 6063, with two parallel, integrated Zero-backlash rail guide systems, allows high load capacities and an optimal sequence for the movement of larger masses at high speed.

In the linear units CTJ is used a pre-tensioned steel reinforced AT polyurethane timing toothed belt. In conjunction with a Zero-backlash drive pulley high moments with alternating loads with good positioning accuracy, low wear and low noise can be realized.

The in the Profile slot driving Polyurethane timing belt, protects all the parts in the Profile from dust and other contaminations.

Different carriage lengths with lubrication port allows for easy re-lubrication of the Ball rail guide system and allows the possibility to attach additional accessories. The re-lubrication can also be done through maintenance holes on the side of the Profile.

The aluminum profile includes T-slots for fixing the Linear Unit and for attaching sensors and switches. Also, a Reed switch can be used here.

For the linear units CTJ various adaptation options, for attaching (or redirecting), for Motors or Gearboxes are available.

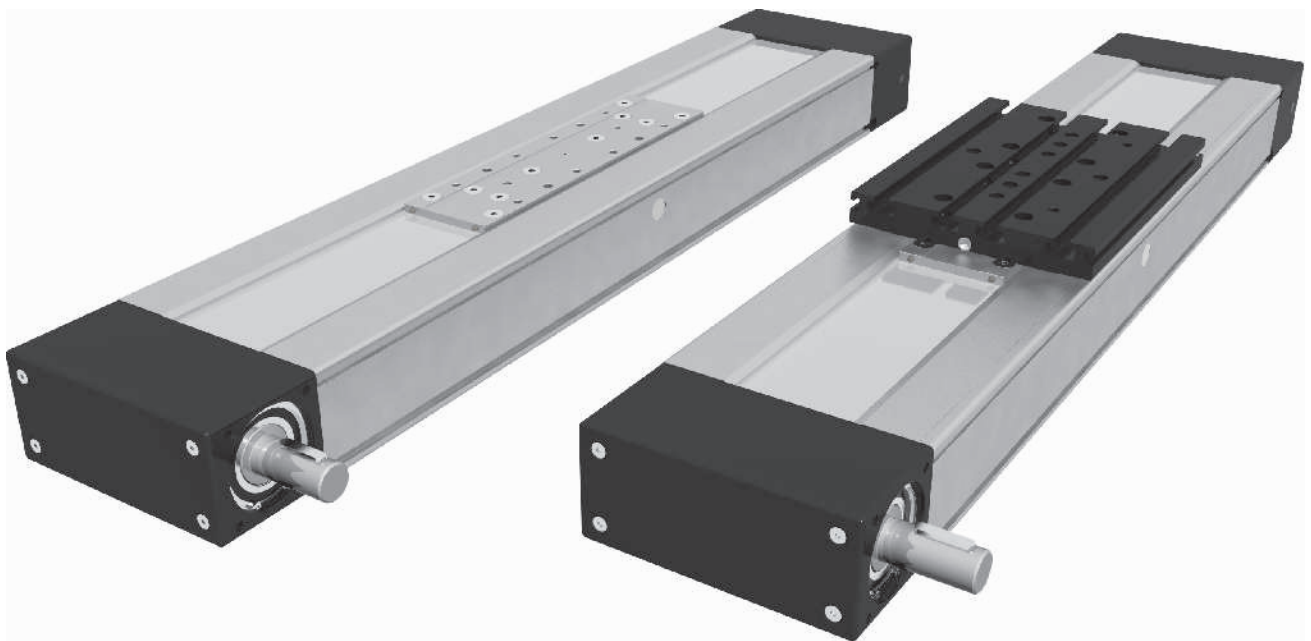

The aluminium profiles are manufactured according to the medium EN 12020-2 standard

Straightness = 0,35 mm/m; Max. torsion = 0,35 mm/m; Angular torsion = 0,2 mm/40 mm; Parallelism = 0,2

STRUCTURAL DESIGN

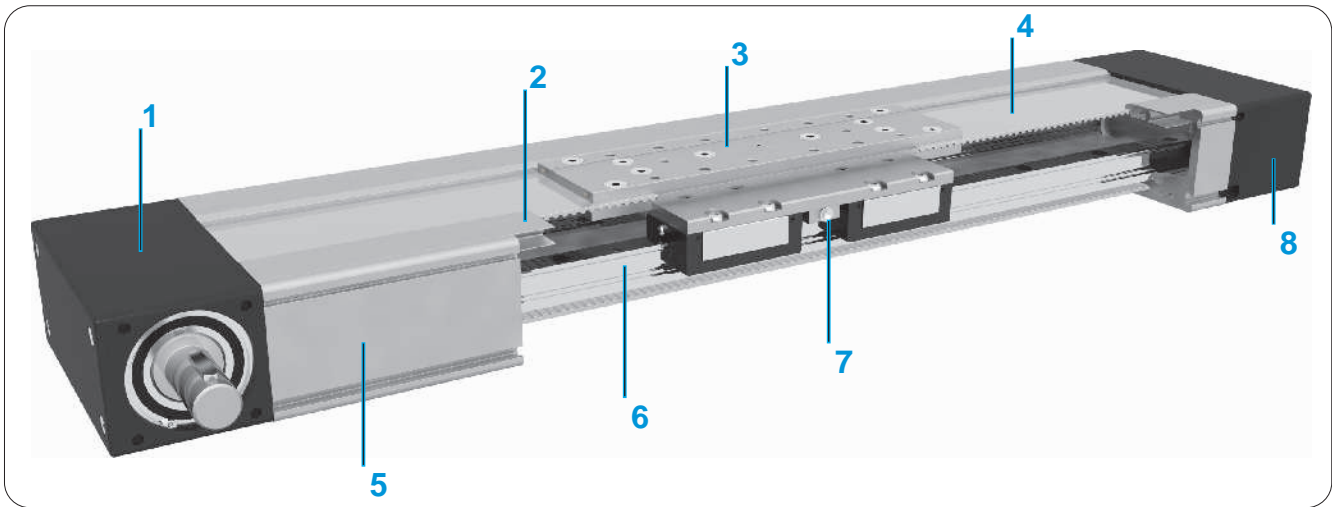

- 1 - Drive block with pulley
- 2- Aluminum cover
- 3 - Carriage; with built in Magnets
- 4 - AT polyurethane toothed belt with steel tension cords
- 5- Aluminium profile-Hard anodized
- 6 - Two integrated Linear Ball Guideways
- 7 - Central lubrication port on both sides
- 8 - Tension End with integrated belt tensionin system

HOW TO ORDER

	CTJ	-	145	-	1000	-	L	-	1	-	R	-	1
Series :	_____												
CTJ	_____												
Size :	_____												
90	_____												
110	_____												
145	_____												
200	_____												
Absolute stroke (mm)	_____												
Carriage Version :	_____												
S : Short	_____												
L : Long	_____												
Type of drive pulley :	_____												
1 : Pulley with journal	_____												
10 : Pulley with journal (without Keyway)	_____												
2 : Pulley with journal on both sides	_____												
20 : Pulley with journal on both sides (without Keyway)	_____												
3 : Without drive unit	_____												
! CTJ 200 pulley 2 or 20 can only have the motor mounted on the left - L or right - R side.	_____												
Drive journal position :	_____												
L : Journal on left side	_____												
R : Journal on right side	_____												
Without : For type of drive pulley 2 and 3	_____												
Connection plate :	_____												
0: Without	_____												
1: With	_____												

TECHNICAL DATA

General technical data for CTJ series

Linear Unit	Carriage length Lv [mm]	Load capacity		Dynamic moment			Moved mass [kg]	Maximum Repeatability [mm]	* Maximum length Lmax [mm]	Planar moment of inertia	
		Dynamic C [N]	Static C0 [N]	Mx [Nm]	My [Nm]	Mz [Nm]				ly [cm ⁴]	lz [cm ⁴]
CTJ 90 S	102	4620	6930	127	12,6	25,2	0,20	± 0,08	6000	13,5	106,5
CTJ 90 L	156	9240	13860	254	290	290	0,35	± 0,08			
CTJ 110 S	170	19800	28200	610	147	295	0,64	± 0,08	6000	31,0	215,7
CTJ 110 L	215	39600	56400	1220	1680	1680	0,98	± 0,08			
CTJ 145 S	180	34200	48400	1500	325	650	1,35	± 0,08	6000	78,6	699,5
CTJ 145 L	240	68400	96800	3000	3420	3420	2,25	± 0,08			
CTJ 200 S	265	49600	68600	3230	557	1114	3,05	± 0,08	6000	376,5	2734,5
CTJ 200 L	405	99200	137200	6470	8680	8680	5,70	± 0,08			

* For lengths over the stated value in the table above please contact us

Recommended values of loads

All the data of static and dynamic moments and load capacities stated in the upper table are theoretical without considering any safety factor. The safety factor depends on the application and its requested safety. We recommend a minimum safety factor (fv =5.0)

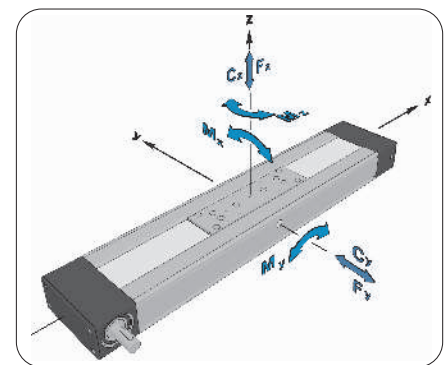

Modulus of elasticity / Elastizitätsmodul

E = 70000 N / mm

Drive and belt data for CTJ series

Linear Unit	Maximum travel speed [m / s]	Maximum drive torque [Nm]	* No load torque [Nm]	Puley drive ratio [mm / rev]	Pulley diameter [mm]	Belt type	Belt width [mm]	Max. force transmitted by belt [N]	Limit of belt elasticity [N]	Specific spring constant Cspec [N]
CTJ 90 S	5	7,5	0,40	90	28,65	AT 3	35	520	1610	402500
CTJ 90 L			0,42							
CTJ 110 S	6	15,7	0,98	120	38,20	AT 5	50	820	3840	960000
CTJ 110 L			1							
CTJ 145 S	6	33,6	1,48	165	52,52	AT 5	70	1280	5440	1360000
CTJ 145 L			1,5							
CTJ 200 S	6	129	2,3	250	79,58	AT 10	100	3250	17400	4350000
CTJ 200 L			2,8							

* The stated values are for strokes up to 500mm. No Load Torque value increases with stroke elongation

Mass and mass moment of inertia

Linear Unit	Carriage length Lv [mm]	Mass of linear unit [kg]	Mass moment of inertia [10 ⁻⁵ kg·m ²]
CTJ 90 S	102	1,7 + 0,0048 * Stroke [mm]	7 + 0,0031 * Stroke [mm]
CTJ 90 L	156	2,1 + 0,0048 * Stroke [mm]	11 + 0,0031 * Stroke [mm]
CTJ 110 S	170	3,6 + 0,0072 * Stroke [mm]	36 + 0,013 * Stroke [mm]
CTJ 110 L	215	4,2 + 0,0072 * Stroke [mm]	49 + 0,013 * Stroke [mm]
CTJ 145 S	180	7,2 + 0,0127 * Stroke [mm]	145 + 0,033 * Stroke [mm]
CTJ 145 L	240	8,8 + 0,0127 * Stroke [mm]	208 + 0,033 * Stroke [mm]
CTJ 200 S	265	20,2 + 0,0245 * Stroke [mm]	778 + 0,187 * Stroke [mm]
CTJ 200 L	405	26,2 + 0,0245 * Stroke [mm]	1210 + 0,187 * Stroke [mm]

Mass calculation doesn't include mass of motor, reduction gear, switches and clamps.



DIMENSIONS

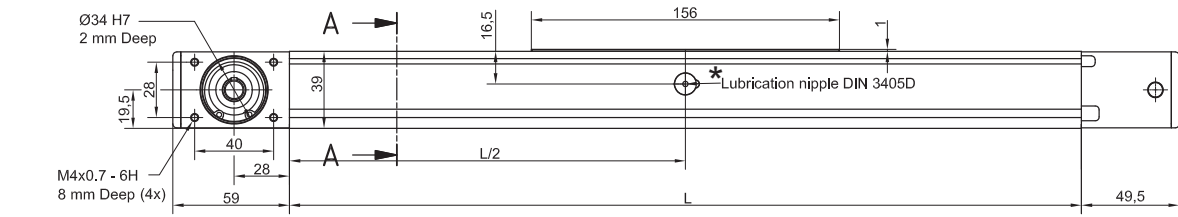

Linear Unit doesn't include any safety stroke.

TYPE 1 L and 1 R

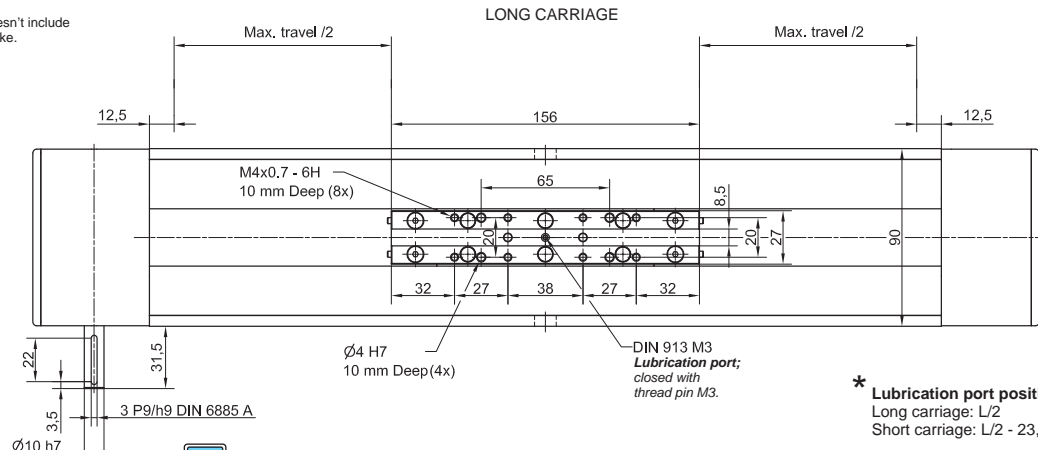

* Lubrication port position:
Long carriage: L/2
Short carriage: L/2 - 23,7 mm

Journal with or without Keyway.

All dimensions in mm;
Drawings scales are not equal.

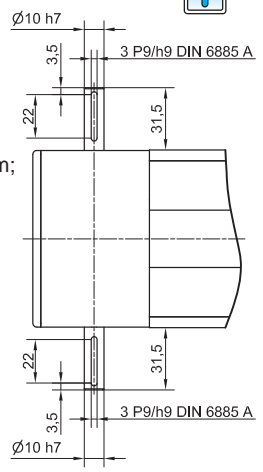

TYPE 2

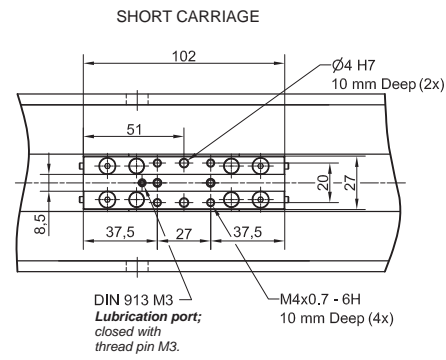

Defining of the linear module length

$L = \text{Effective stroke} + 2 \times \text{Safety travel} + L_v + 25 \text{ mm}$

Double-Carriage

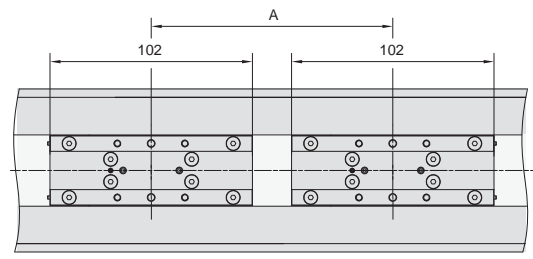
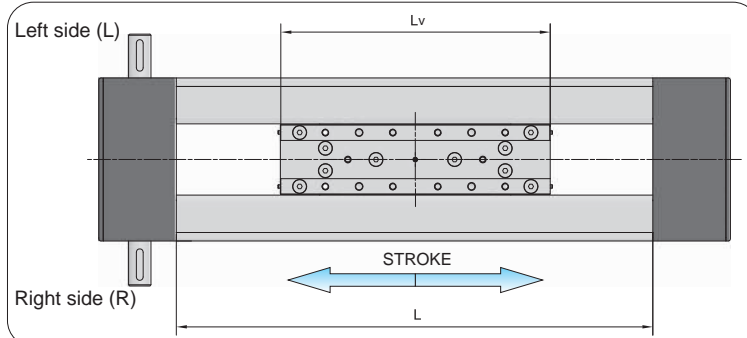

Only with Short carriage version.

$L = \text{Effective stroke} + 2 \times \text{Safety travel} + A + 127 \text{ mm}$ } $A \geq 102 \text{ mm}$

For ordering code please contact us.

DIMENSIONS

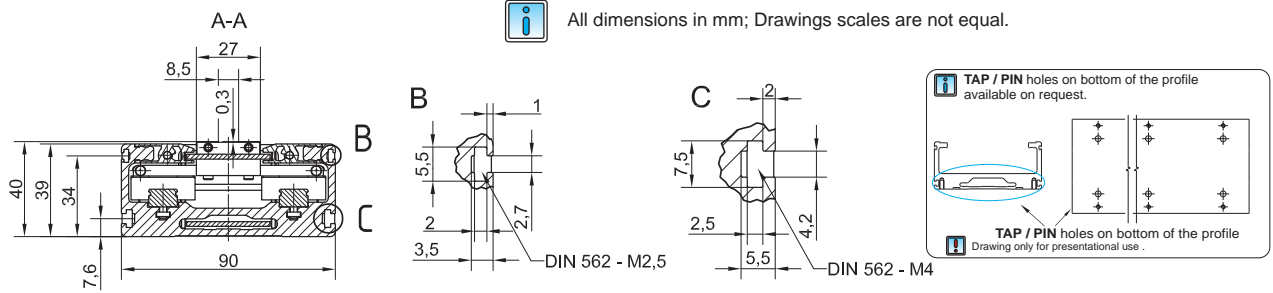

CONNECTION PLATE

CTJ 90 L

CTJ 90 S

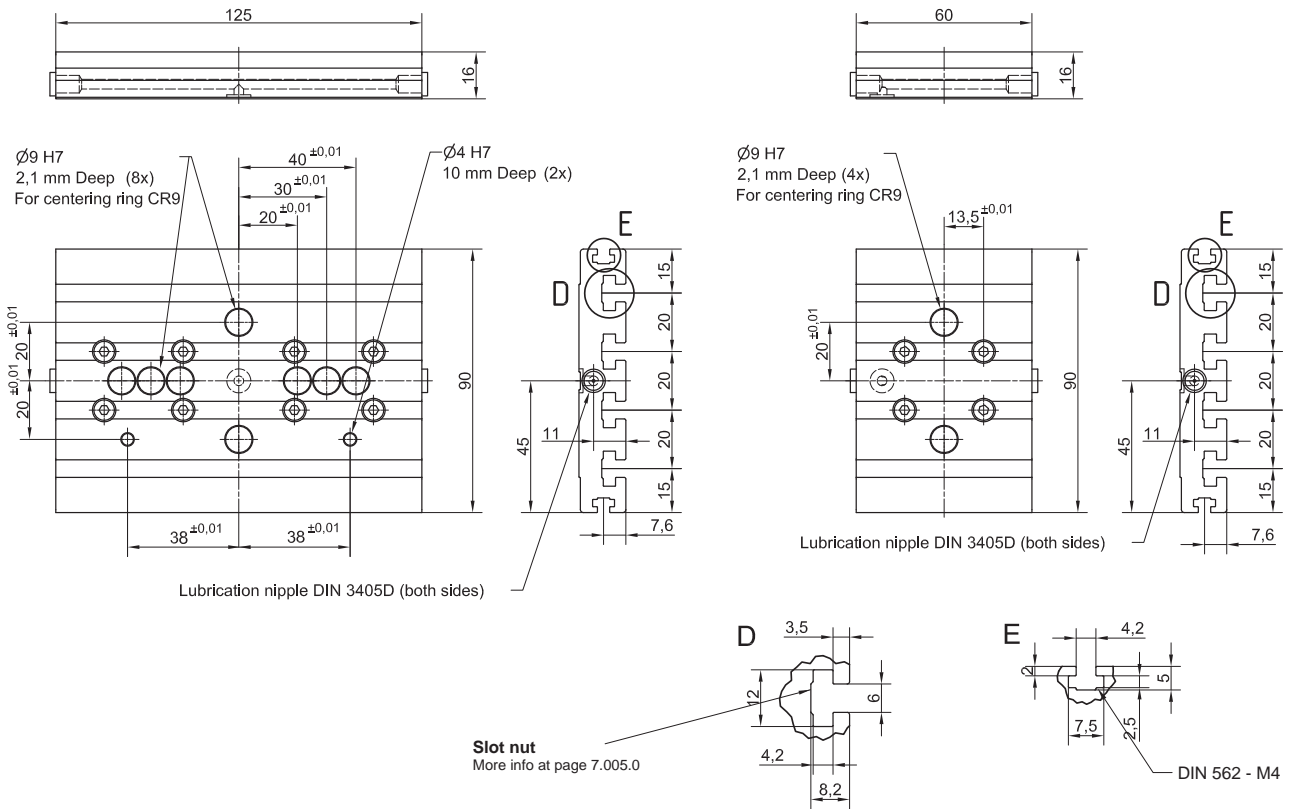

Linear Unit	Plate length [mm]	Weight [kg]	Code
CTJ 90 S	60	0,2	48853
CTJ 90 L	125	0,4	48854

Mounting elements for mounting the connection plate on the Linear unit are included.

MOTOR	CTJ 90	CTJ 90	CTJ 90
	Available on request	Available on request	Available on request
GEAR REDUCER + MOTOR	CTJ 90	CTJ 90	CTJ 90
	Available on request	Available on request	Available on request
GEAR REDUCER 90° + MOTOR	CTJ 90	CTJ 90	CTJ 90
	Available on request	Available on request	Available on request



DIMENSIONS

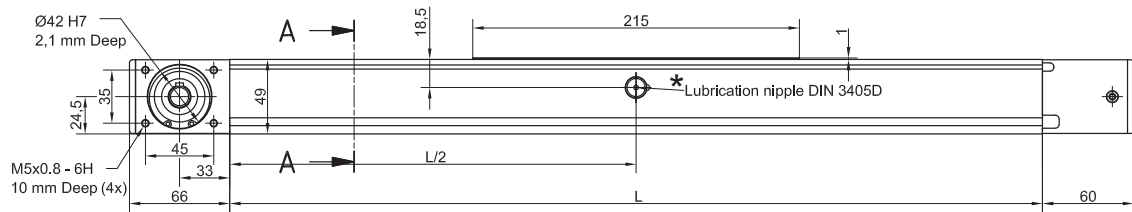

Linear Unit doesn't include any safety stroke.

TYPE 1 L and 1 R

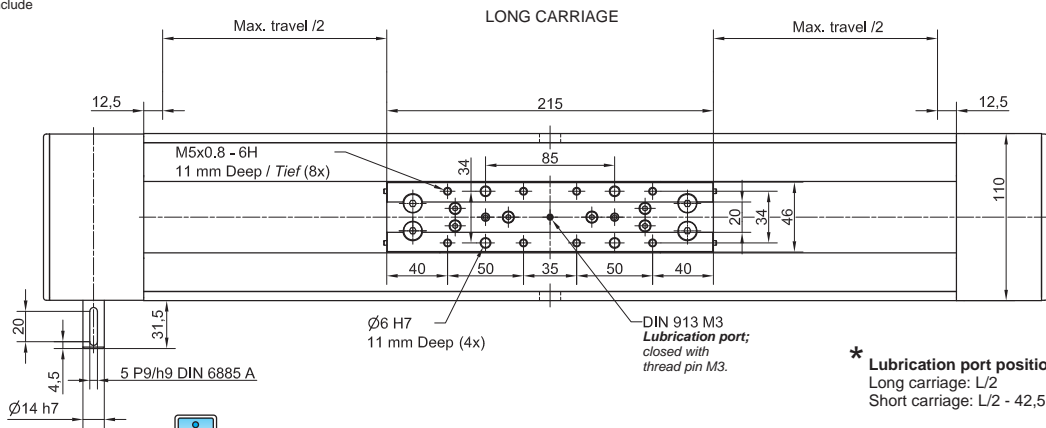

Journal with or without Keyway.

All dimensions in mm; Drawings scales are not equal.

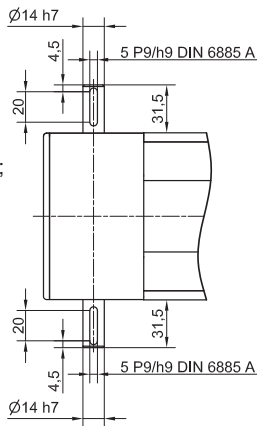

TYPE 2

SHORT CARRIAGE

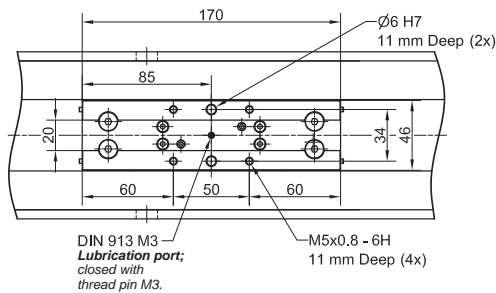

Defining of the linear module length

$L = \text{Effective stroke} + 2 \times \text{Safety travel} + L_v + 25 \text{ mm}$

Double-Carriage

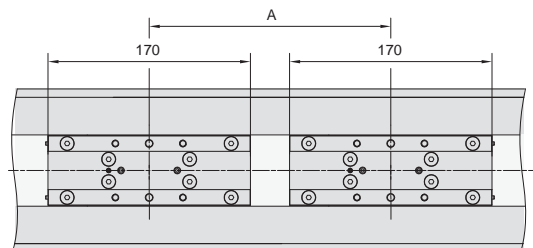
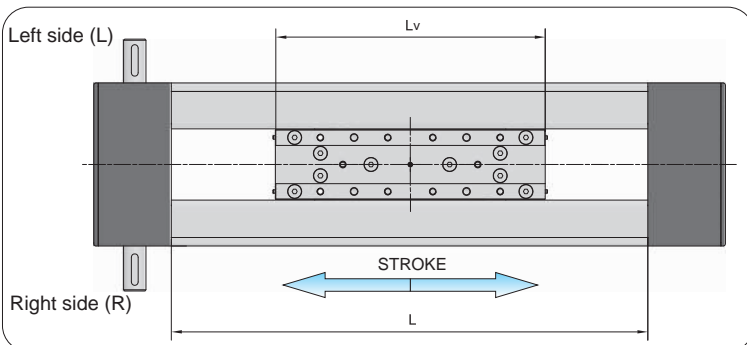

Only with **Short carriage** version.

$L = \text{Effective stroke} + 2 \times \text{Safety travel} + A + 195 \text{ mm}$ } $A \geq 170 \text{ mm}$

For ordering code please contact us.

DIMENSIONS

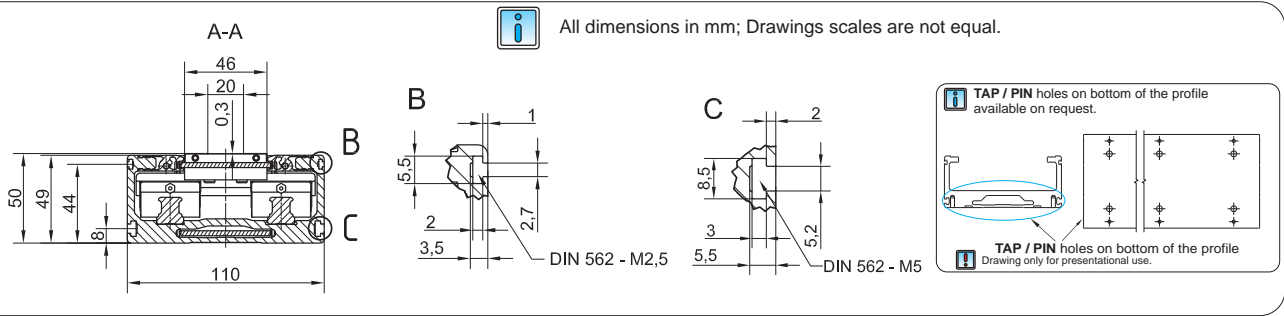

CONNECTION PLATE

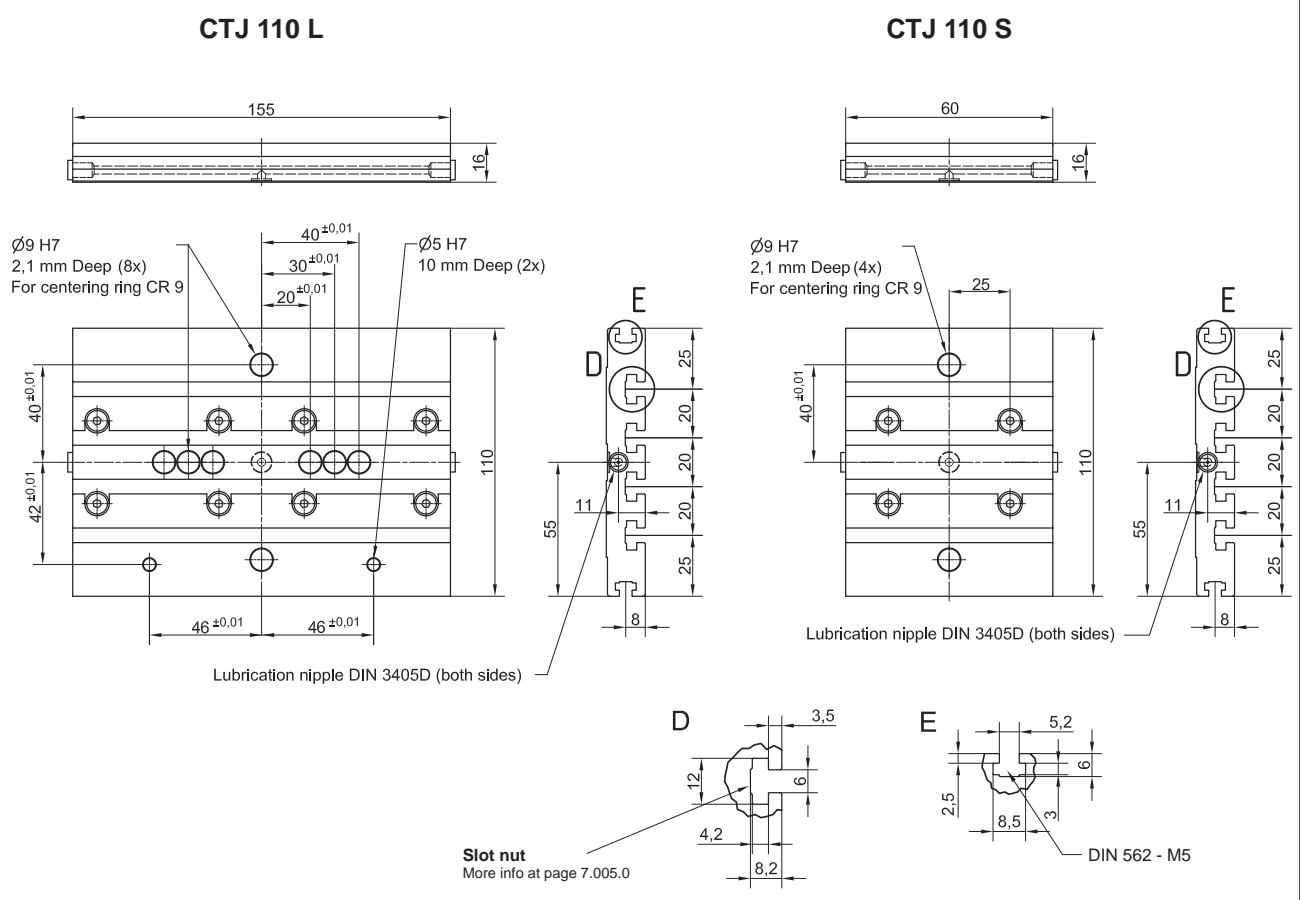

Linear Unit	Plate length [mm]	Weight [kg]	Code
CTJ 110 S	60	0,35	48525
CTJ 110 L	155	0,60	48480

Information icon: Mounting elements for mounting the connection plate on the Linear unit are included.

MOTOR	CTJ 110	CTJ 110	CTJ 110
	Available on request	Available on request	Available on request

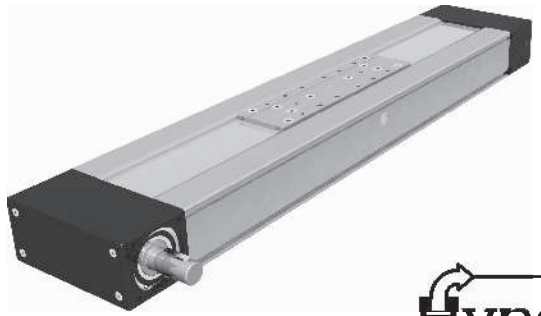

DIMENSIONS

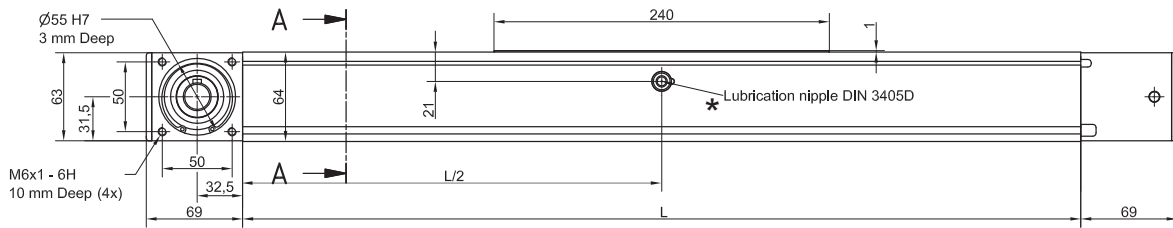

Linear Unit doesn't include any safety stroke.

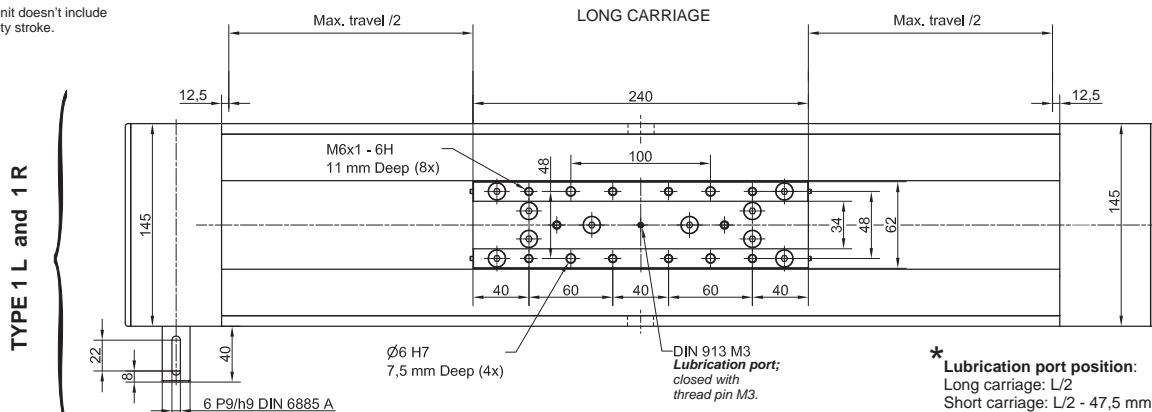

TYPE 1 L and 1 R

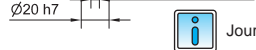

Journal with or without Keyway.

All dimensions in mm; Drawings scales are not equal.

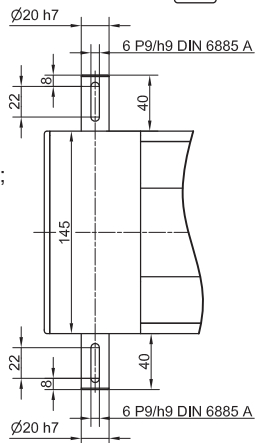

TYPE / TYPE 2

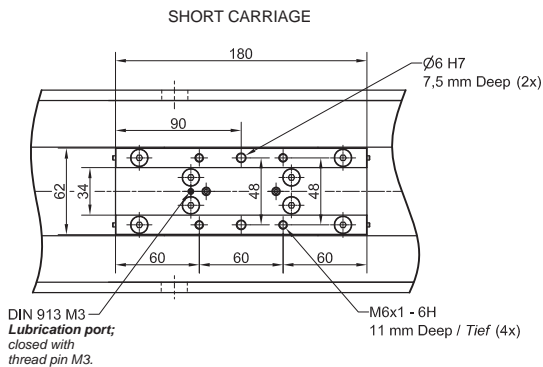

Defining of the linear module length

$L = \text{Effective stroke} + 2 \times \text{Safety travel} + L_v + 25 \text{ mm}$

Double-Carriage

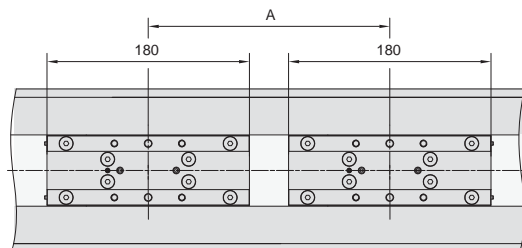
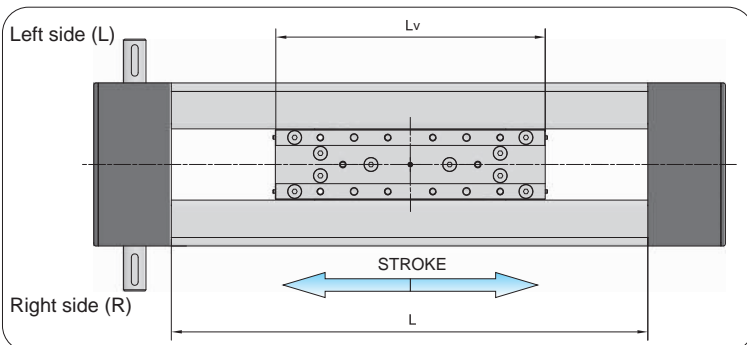

Short carriage version only.

$L = \text{Effective stroke} + 2 \times \text{Safety travel} + A + 205 \text{ mm}$

$A \geq 180 \text{ mm}$

For ordering code please contact us.

DIMENSIONS

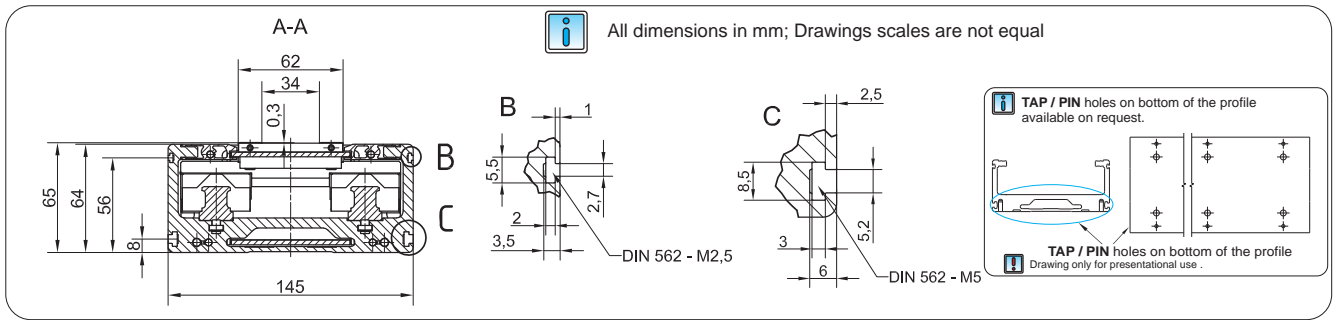

CONNECTION PLATE

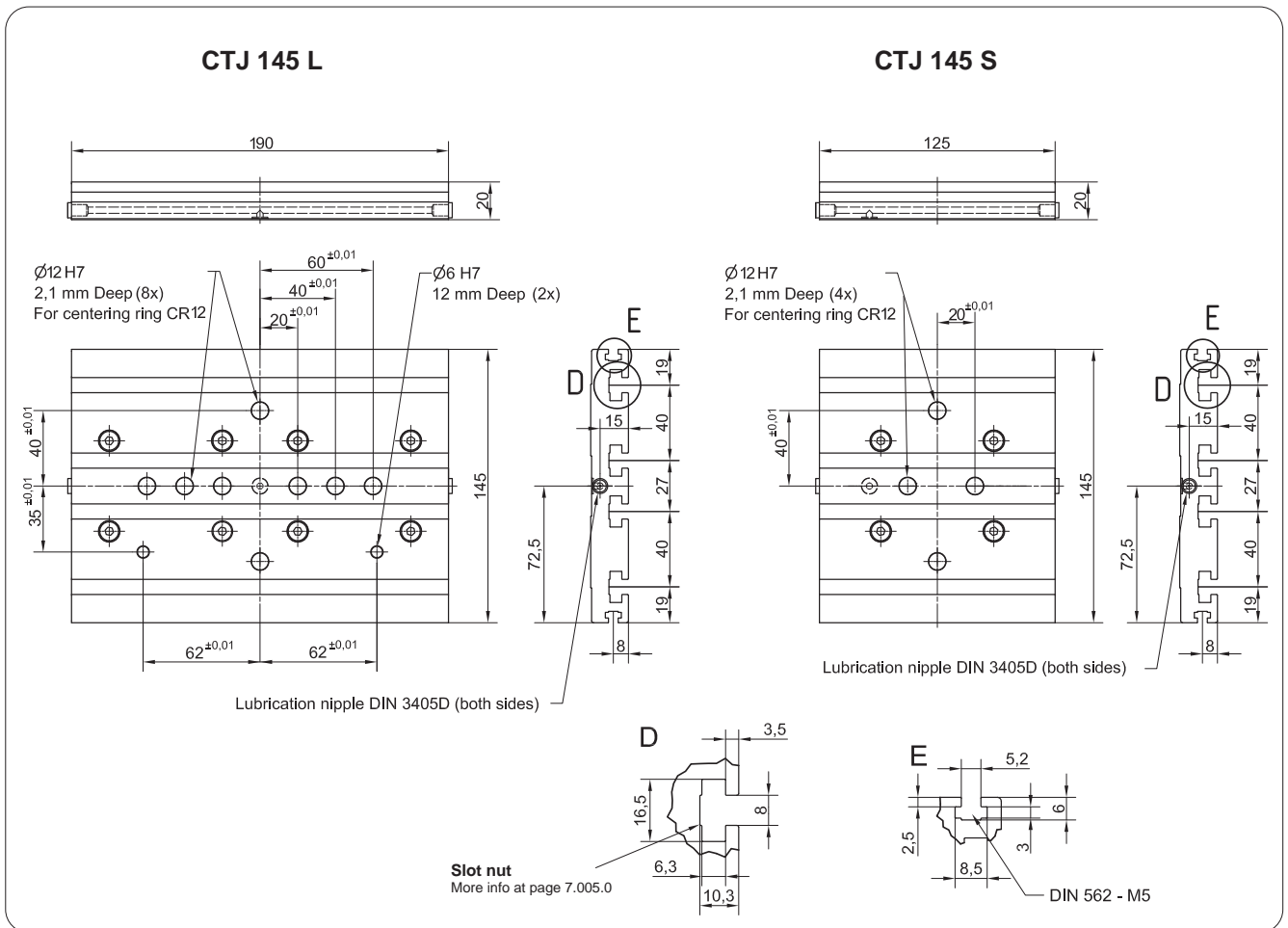

Linear Unit	Plate length [mm]	Weight [kg]	Code
CTJ 145 S	125	0,8	46776
CTJ 145 L	190	1,3	46775

Mounting elements for mounting the connection plate on the Linear unit are included.

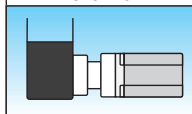
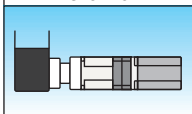
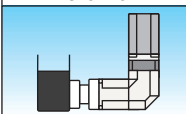
MOTOR	 <p>CTJ 145</p>	GEAR REDUCER + MOTOR	 <p>CTJ 145</p>	GEAR REDUCER 90° + MOTOR	 <p>CTJ 145</p>
	Available on request		Available on request		Available on request



DIMENSIONS

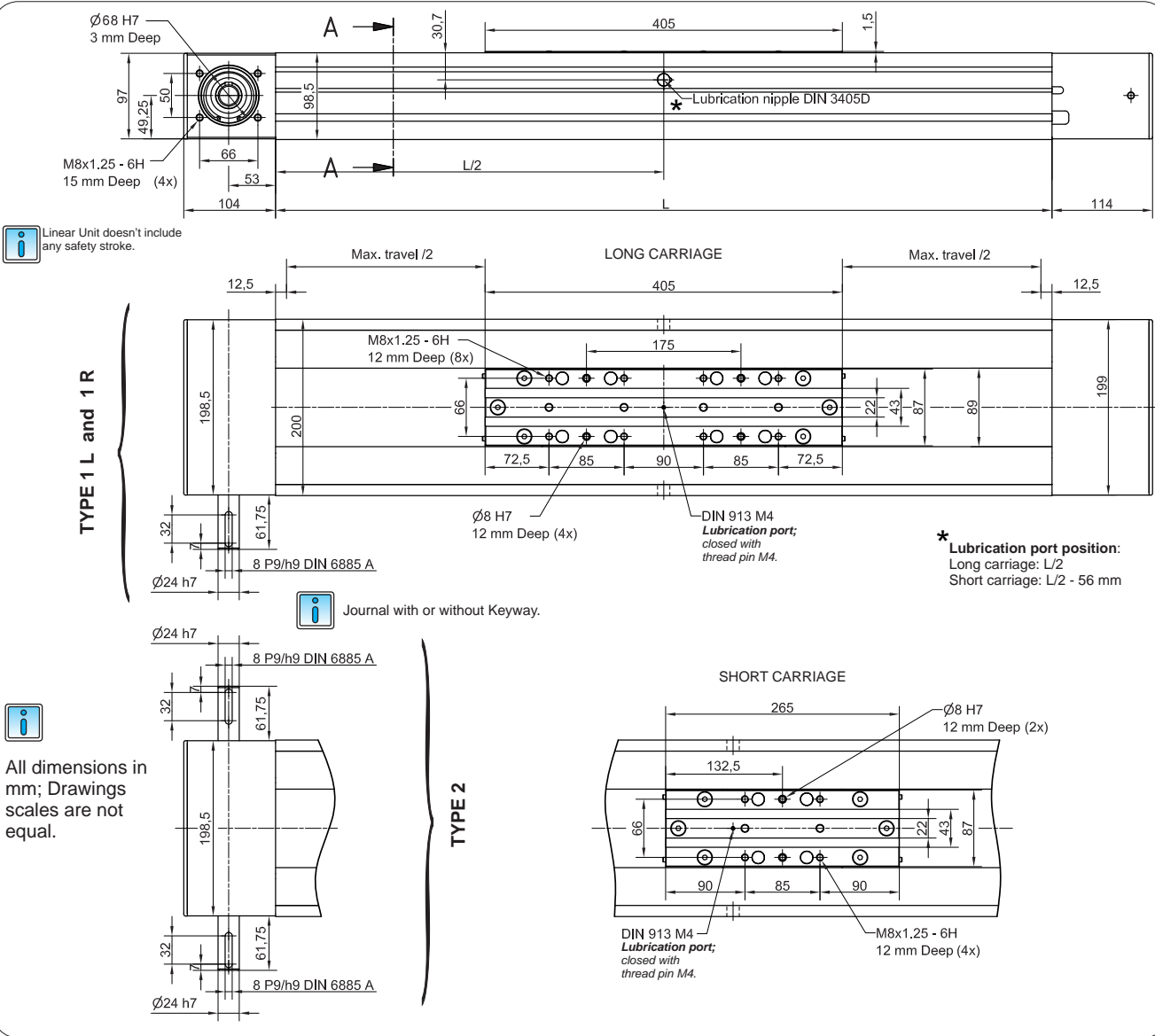

Defining of the linear module length

$L = \text{Effective stroke} + 2 \times \text{Safety travel} + L_v + 25 \text{ mm}$

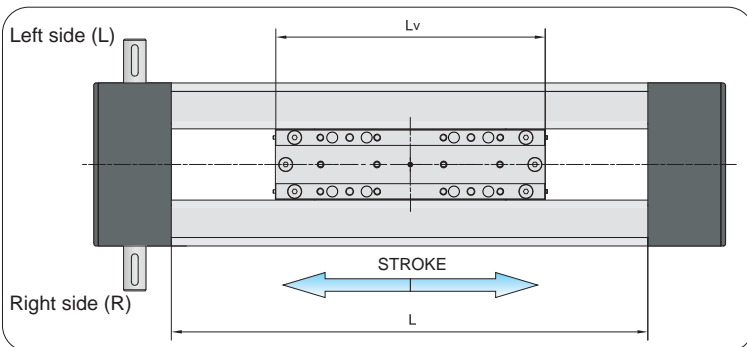

Double-Carriage

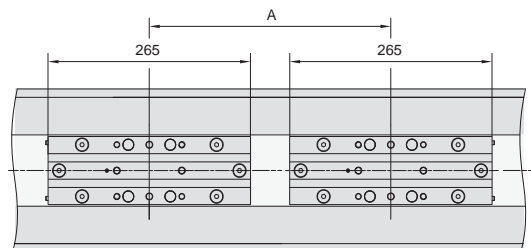

Only with **Short** carriage version.

$L = \text{Effective stroke} + 2 \times \text{Safety travel} + A + 290 \text{ mm}$ } $A \geq 265 \text{ mm}$

For ordering code please contact us

DIMENSIONS

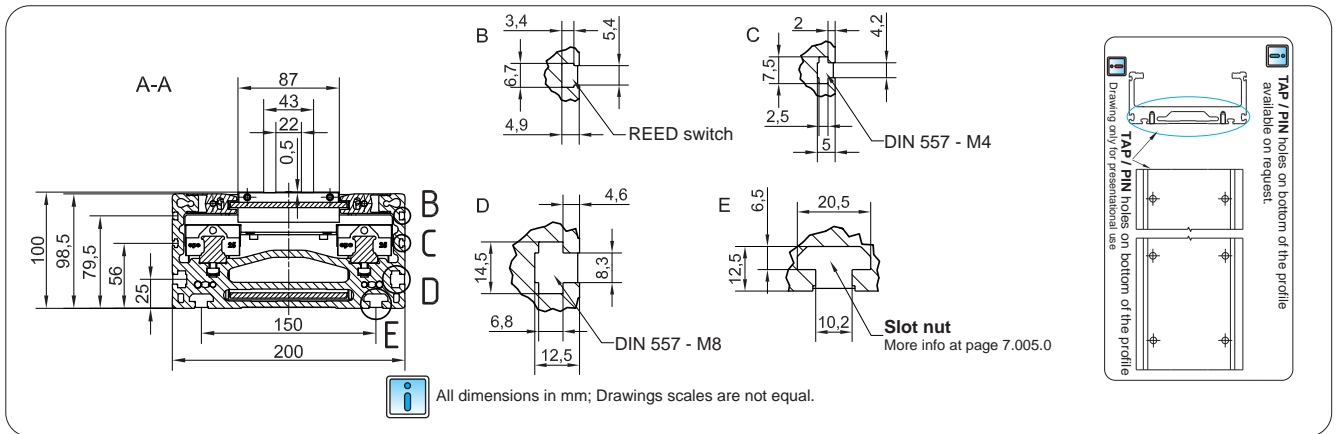

CONNECTION PLATE

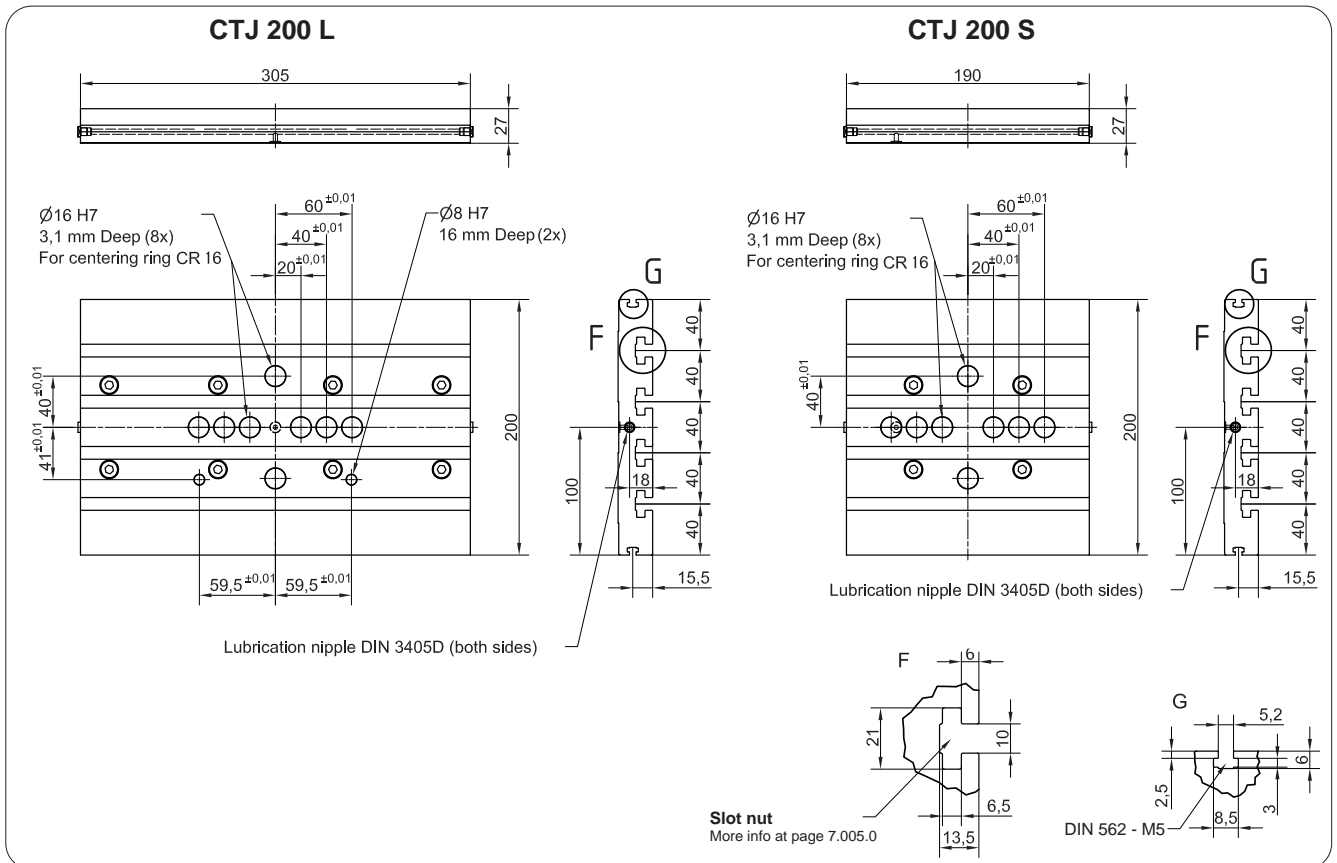

Linear Unit	Plate length [mm]	Weight [kg]	Code
CTJ 200 S	265	2,3	52483
CTJ 200 L	405	3,7	52482

Mounting elements for mounting the connection plate on the Linear unit are included.

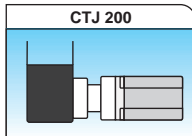
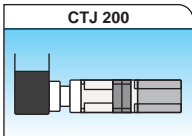
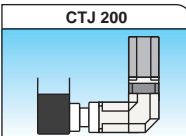
MOTOR	 <p>CTJ 200</p> <p>Available on request</p>	 <p>CTJ 200</p> <p>Available on request</p>	 <p>CTJ 200</p> <p>Available on request</p>
-------	--	--	--



CHARACTERISTICS

The **CTV** series describes Linear Units with a precision ball screw drive and two parallel, integrated, Zero-backlash rail guides. Compact dimensions allow high performance features such as, high speeds, good accuracy and repeatability.

They can easily be combined to multi-axis systems.

Excellent price-/performance ratio and quick delivery time are ensured.

The compact, precision-extruded aluminum Profile from AL 6063, with two parallel, integrated, Zero-backlash rail guide systems, allows high load capacities and optimal cycles for the movement of larger masses at high speed.

In the Linear Units CTV a precision ball screw, with tolerance class ISO7 (ISO5 on request), with reduced backlash of the ball nut is used.

Two parallel circulating antistatic polyurethane sealing strips and an aluminum cover are ensuring to protect all the parts in the profile from dust and other contaminations.

Different carriage lengths with lubrication port allows for easy re-lubrication of the ball screw and Ball rail guide system and allows the possibility to attach additional accessories. The re-lubrication can also be done through maintenance holes on the side of the Profile.

The aluminum profile includes T-slots for fixing the Linear Unit and for attaching sensors and switches. Also, a Reed switch can be used here.

For the linear units CTV various adaptation options, for attaching (or redirecting), for Motors or Gearboxes are available.

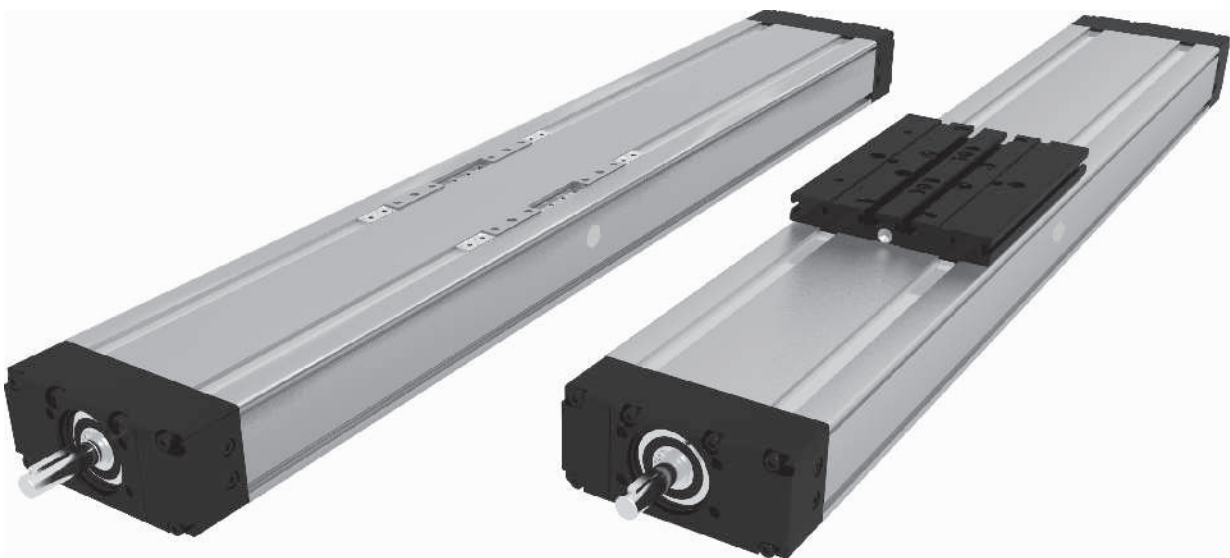

The aluminium profiles are manufactured according to the medium EN 12020-2 standard

Straightness = 0,35 mm/m; Max. torsion = 0,35 mm/m; Angular torsion = 0,2 mm/40 mm; Parallelism = 0,2 mm

STRUCTURAL DESIGN

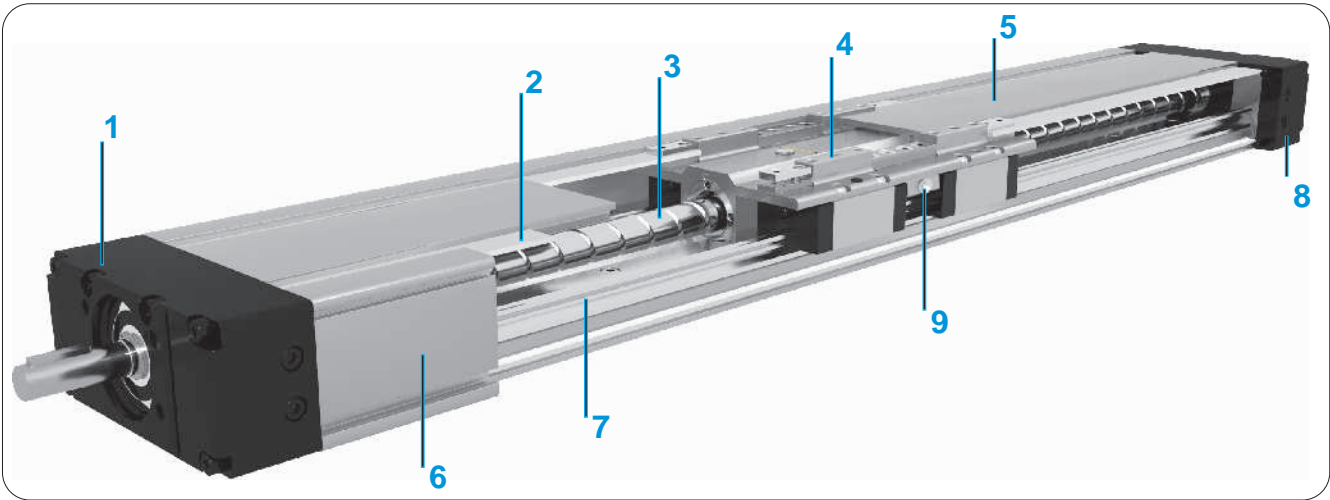

- 1 - Drive block with floating bearing
- 2- Gap-type seal of antistatic PU strip (recirculating)
- 3 - Ball screw tolerance ISO 7 (ISO 5 available on request)
- 4 - Carriage, with built in Magnets
- 5- Aluminum cover
- 6 - Aluminium profile-Hard anodized
- 7 - Two integrated Linear Ball Guideways
- 8 - End block with fixed bearing
- 9 - Central lubrication port; both sides

HOW TO ORDER

CTV - **110** - **1610** - **ISO7** - **1** - **1000** - **L** - **1** - **1**

Series :

CTV

Size :

90

110

145

Ball screw :

CTV 90: $\varnothing 12 \times 5$, $\varnothing 12 \times 10$

CTV 110: $\varnothing 16 \times 5$, $\varnothing 16 \times 10$, $\varnothing 16 \times 16$

CTV 145: $\varnothing 20 \times 5$, $\varnothing 20 \times 10$, $\varnothing 20 \times 20$

Ball screw tolerance :

ISO7 (Standard)

ISO5

Ball screw journal :

0 : Without keyway

1 : With keyway

Absolute stroke (mm):

Carriage Version :

S : Short

L : Long

Connection plate :

0: Without

1: With

Protection cover :

0 : Without antistatic PU Gap-type seal strip

1 : With antistatic PU Gap-type seal strip (Standard)

2 : With Corrosion-resistant protection strip

TECHNICAL DATA

General technical data for CTV series

Linear Unit	Carriage length Lv [mm]	Load capacity		Dynamic moment			Moved mass [kg]	* Maximum length Lmax [mm]	Planar moment of inertia	
		Dynamic C [N]	Static C0 [N]	Mx [Nm]	My [Nm]	Mz [Nm]			ly [cm ⁴]	lz [cm ⁴]
CTV 90 S	35	4616	6924	127	12,6	25,2	0,3	750	13,6	112,1
CTV 90 L	100	9232	13848	254	302	302	0,5			
CTV 110 S	39	19800	28200	654	147	295	0,63	1500	28,4	192,6
CTV 110 L	124	39600	56400	1308	1680	1680	1,36			
CTV 145 S	49	34200	48400	1500	325	650	1,19	1800	83,1	656,9
CTV 145 L	149	68400	96800	3010	3420	3420	2,61			

* For lengths over the stated value in the table above please contact us.

Recommended values of loads:

All the data of static and dynamic moments and load capacities stated in the upper table are theoretical without considering any safety factor. The safety factor depends on the application and its requested safety. We recommend a minimum safety factor (fv =5.0)

Modulus of elasticity

E = 70000 N / mm

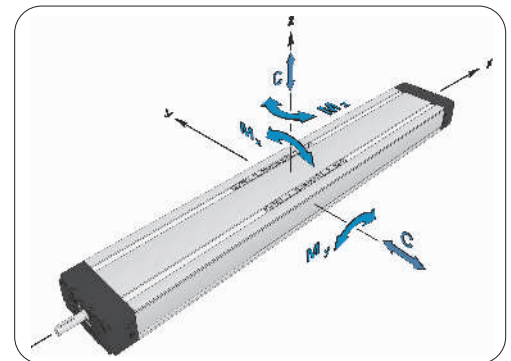

Ball Screw Drive data

Linear Unit	1 Maximal travel speed [m / s]	2 No load torque		Lead constant [mm / rev]	Ball Nut type (Preloaded)	Ball screw [d x l]	3 Max. repeatability precision [mm]		Dynamic axial load capacity Ca [N]	Maximal drive torque without Keyway Ma [Nm]
		Carriage: S	Carriage: L				STANDARD	ISO5		
CTV 90	26,7·10 ³ ·l / L ² [mm]	0,07	0,09	5	RSY	12 x 5	± 0,02	± 0,01	3800	3,4
		0,06	0,08	10		12 x 10	± 0,02	± 0,01	2500	4,4
CTV 110	34,2·10 ³ ·l / L ² [mm]	0,11	0,13	5	RSY	16 x 5	± 0,02	± 0,01	7500	6,6
		0,1	0,12	10		16 x 10	± 0,02	± 0,01	7020	12,5
		0,09	0,11	16		16 x 16	± 0,02	± 0,01	7050	20,0
CTV 145	44,3·10 ³ ·l / L ² [mm]	0,28	0,3	5	RSY	20 x 5	± 0,02	± 0,01	10800	9,5
		0,26	0,28	10		20 x 10	± 0,02	± 0,01	11980	21,0
		0,24	0,26	20		20 x 20	± 0,02	± 0,01	7650	27,0

¹ For travel speed over the stated value in the table above please contact us

² The stated values are for strokes up to 500mm. No Load Torque value increases with stroke

³ Please use ball nut with the preload of 2% please contact us

i Reduced effective diameter at journal with keyway decreases values of max. drive torque.

Linear Unit	Permissible drive torque (with Keyway) Mp [Nm]
CTV 90	-
CTV 110	5,3
CTV 145	11,9

Mass and mass moment of inertia

Linear Unit	Carriage length Lv [mm]	Mass of linear unit [kg]	Mass moment of inertia [10 ⁻⁵ kg·m ²]
CTV 90 S	35	1,6 + 0,006·Stroke [mm]	0,3 + 0,002·Stroke [mm]
CTV 90 L	100	2,2 + 0,006·Stroke [mm]	0,4 + 0,002·Stroke [mm]
CTV 110 S	39	3,3 + 0,008·Stroke [mm]	1,1 + 0,005·Stroke [mm]
CTV 110 L	124	4,6 + 0,008·Stroke [mm]	2,0 + 0,005·Stroke [mm]
CTV 145 S	49	5,7 + 0,015·Stroke [mm]	4,2 + 0,013·Stroke [mm]
CTV 145 L	149	8,4 + 0,015·Stroke [mm]	6,1 + 0,013·Stroke [mm]

i Mass calculation doesn't include mass of motor, reduction gear, switches and clamps.

DIMENSIONS

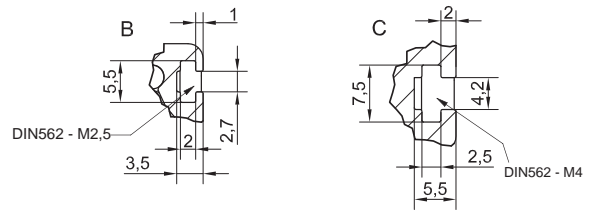
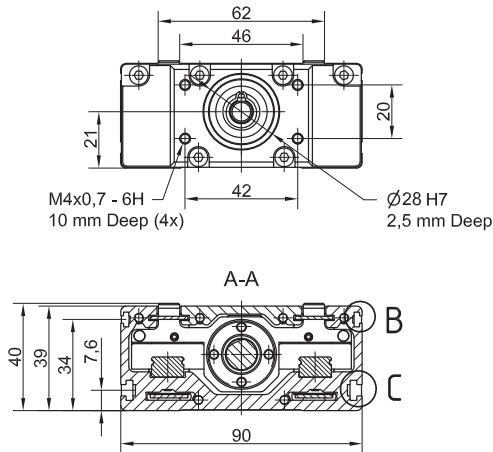

All dimensions in mm; Drawings scales are not equal..

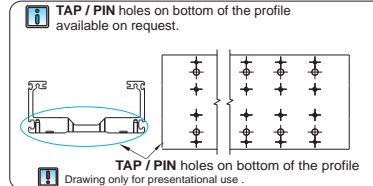

CONNECTION PLATE

CTV 90 L

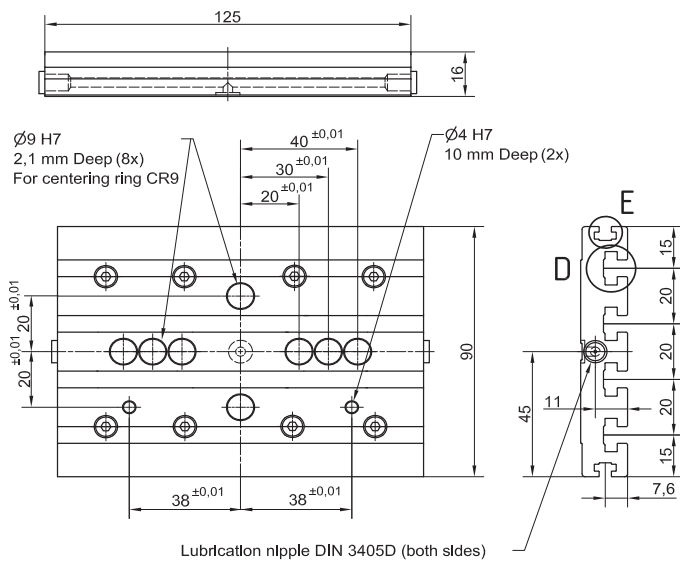

CTV 90 S

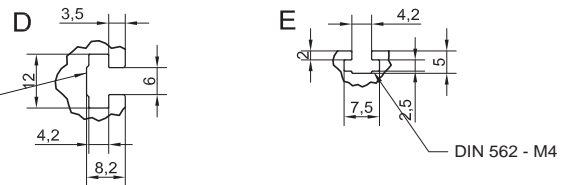
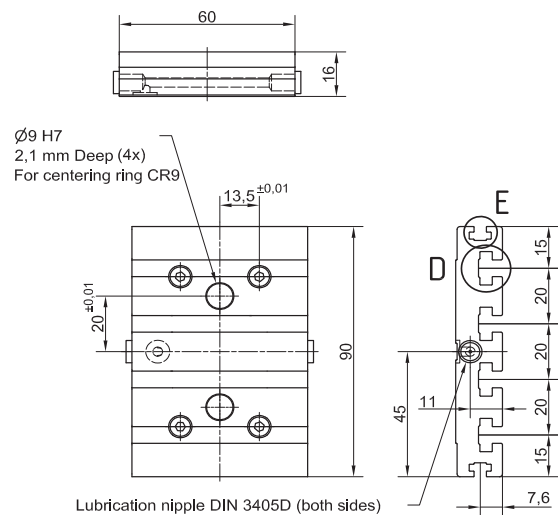

Slot nut
More info at page 7.005.0

Mounting elements for mounting the connection plate on the Linear unit are included.

Linear Unit	Plate length [mm]	Weight [kg]	Code
CTV 90 S	60	0,21	46906
CTV 90 L	125	0,44	46907

MOTOR - MOTOR SIDE DRIVE

CTV 90

Available on request

MOTOR

CTV 90

Available on request

GEAR REDUCER + MOTOR

CTV 90

Available on request

GEAR REDUCER 90° + MOTOR

CTV 90

Available on request

Verfügbarkeit (Lieferzeit) auf Anfrage

DIMENSIONS

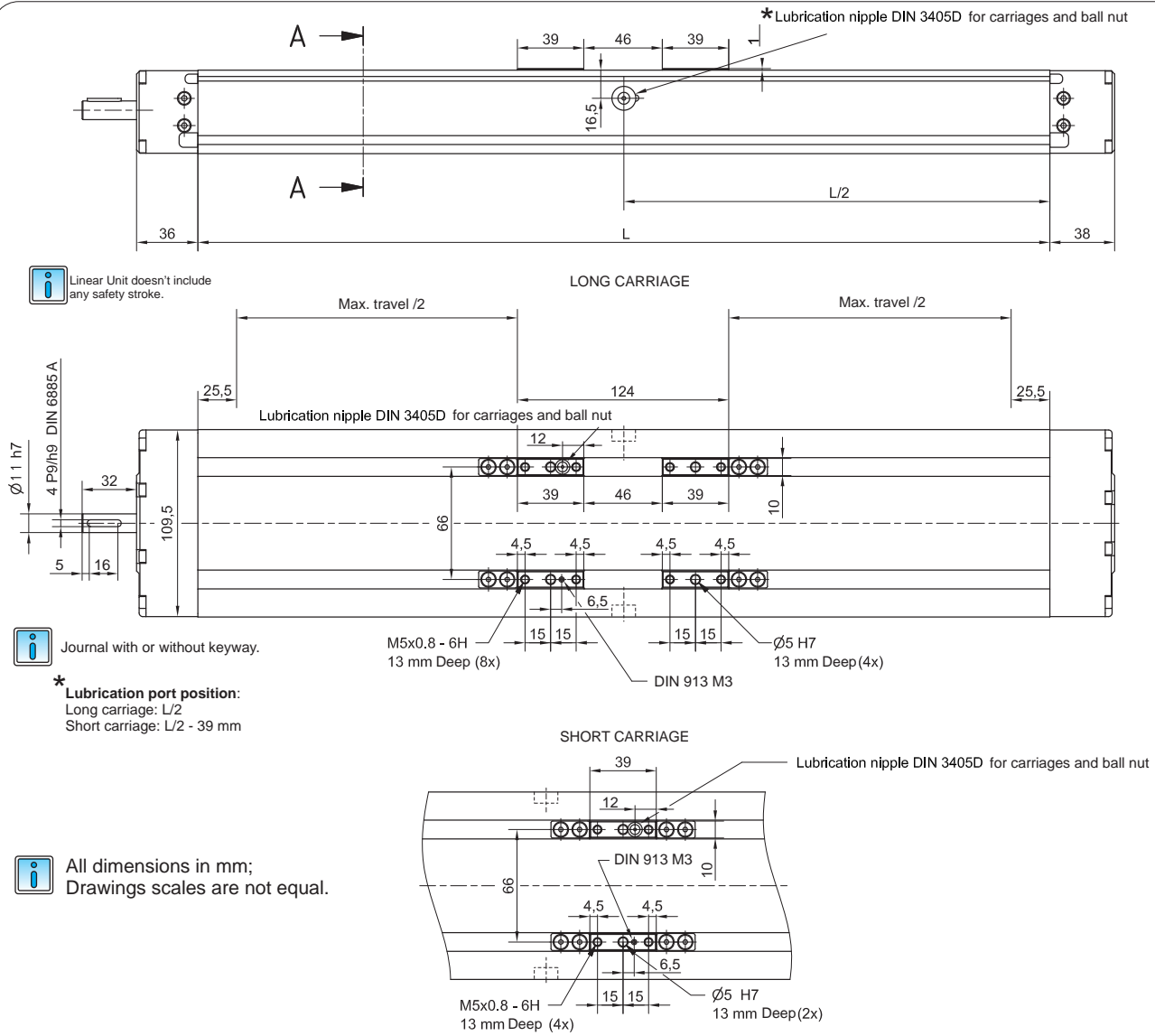

Linear Unit doesn't include any safety stroke.

Journal with or without keyway.

* Lubrication port position:
Long carriage: L/2
Short carriage: L/2 - 39 mm

All dimensions in mm;
Drawings scales are not equal.

Defining of the linear module length

$L = \text{Effective stroke} + 2 \times \text{Safety travel} + L_v + 51 \text{ mm}$

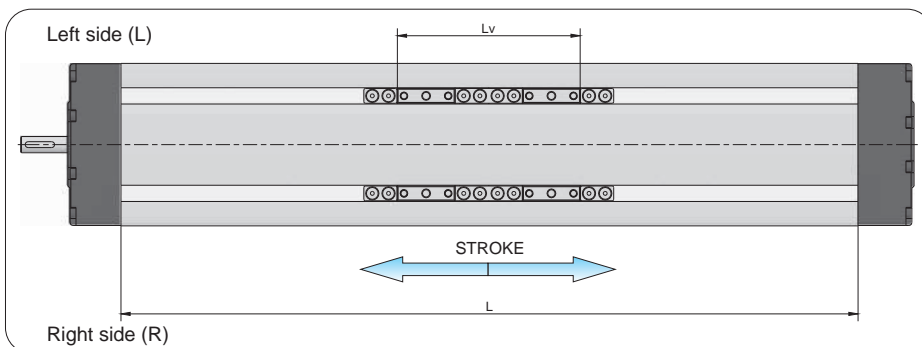

Double-Carriage

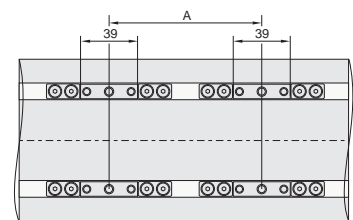

Only with **Short** carriage version.

$L = \text{Effective stroke} + 2 \times \text{Safety travel} + A + 90 \text{ mm}$ } $A \geq 85 \text{ mm}$

For ordering code please contact us

DIMENSIONS

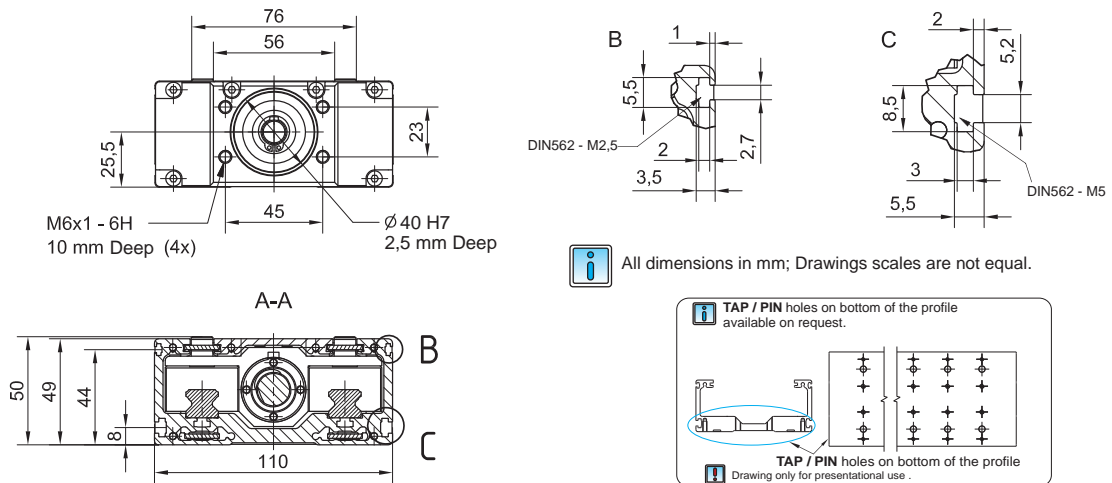

CONNECTION PLATE

CTV 110 L

CTV 110 S

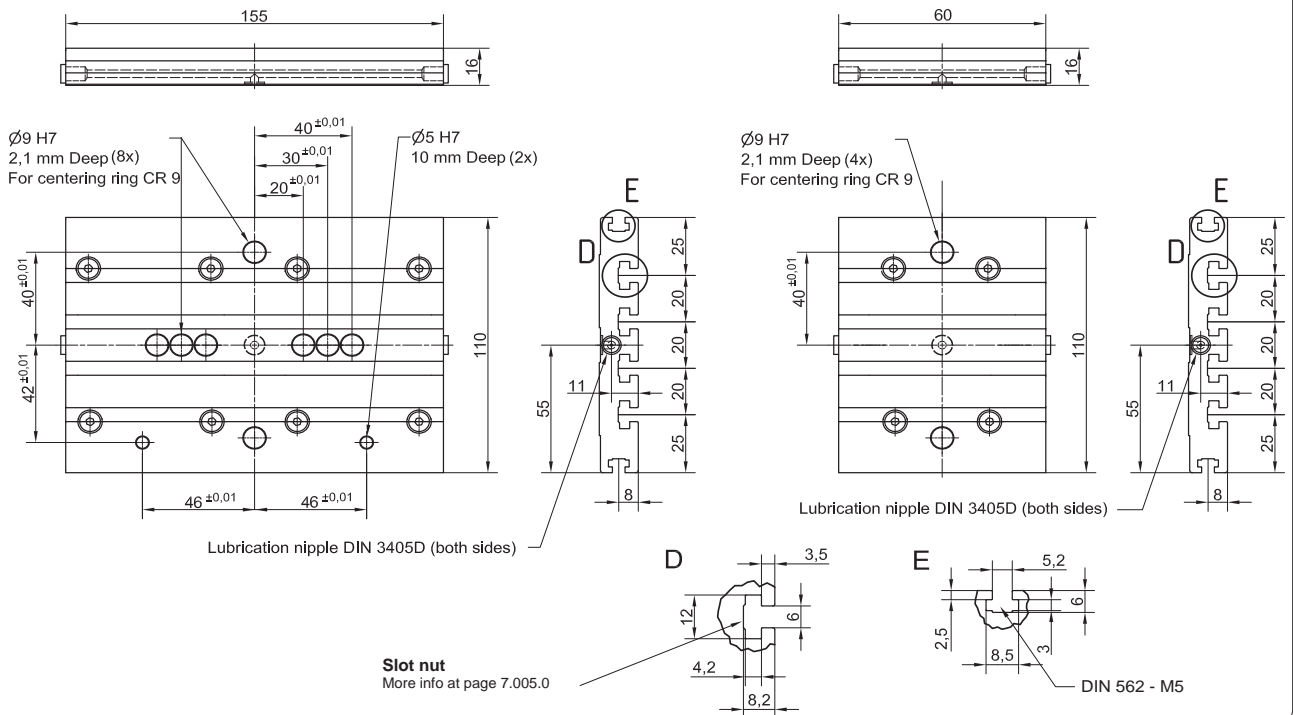

Linear Unit	Plate length [mm]	Weight [kg]	Code
CTV 110 S	60	0,37	48348
CTV 110 L	155	0,74	48349

Mounting elements for mounting the connection plate on the Linear unit are included.

MOTOR - MOTOR SIDE DRIVE

CTV 110

Available on request

MOTOR

CTV 110

Available on request

GEAR REDUCER + MOTOR

CTV 110

Available on request

GEAR REDUCER 90° + MOTOR

CTV 110

Available on request

Verfügbarkeit (Lieferzeit) auf Anfrage

DIMENSIONS

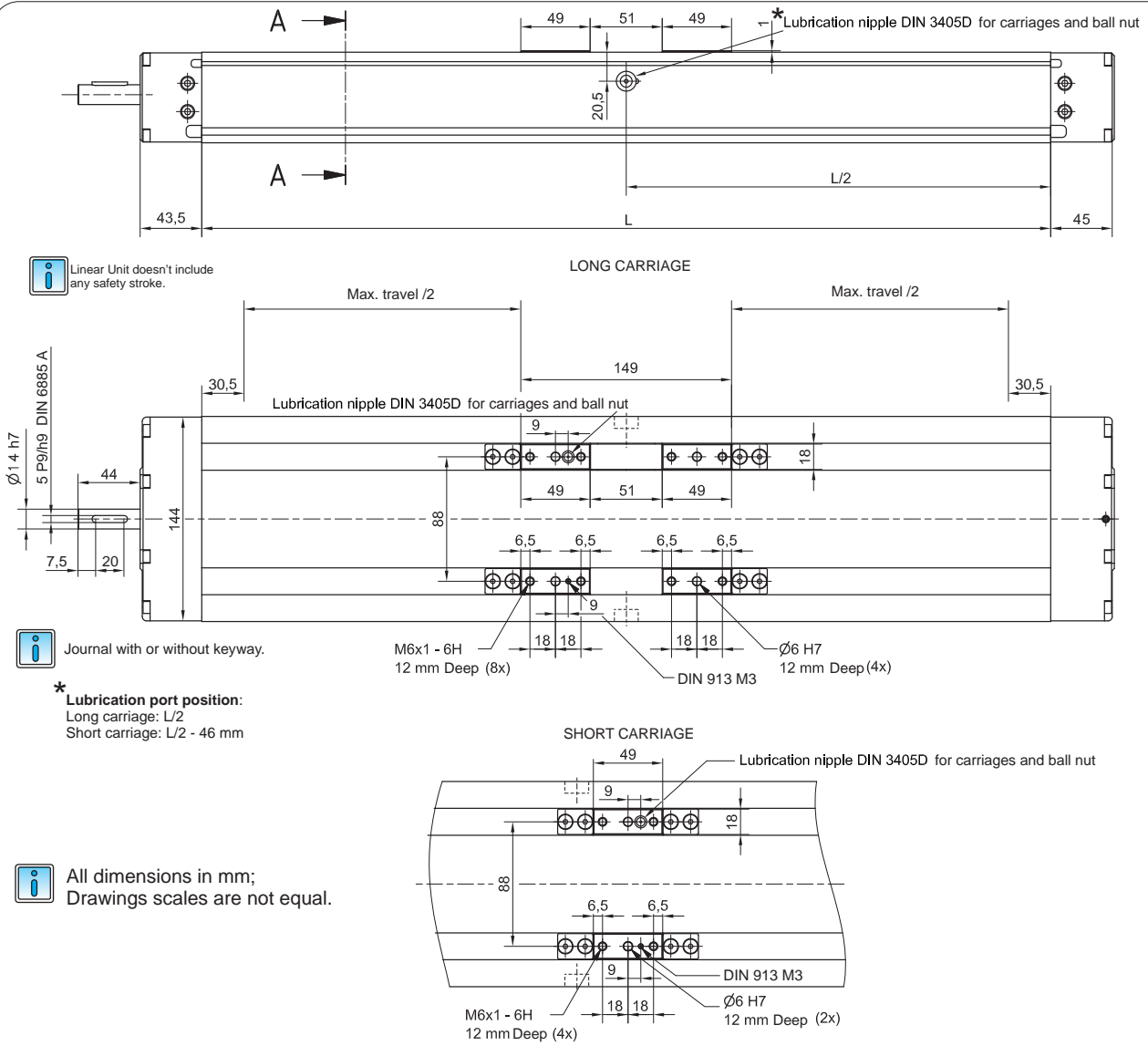

Defining of the linear module length

$L = \text{Effective stroke} + 2 \times \text{Safety travel} + L_v + 61 \text{ mm}$

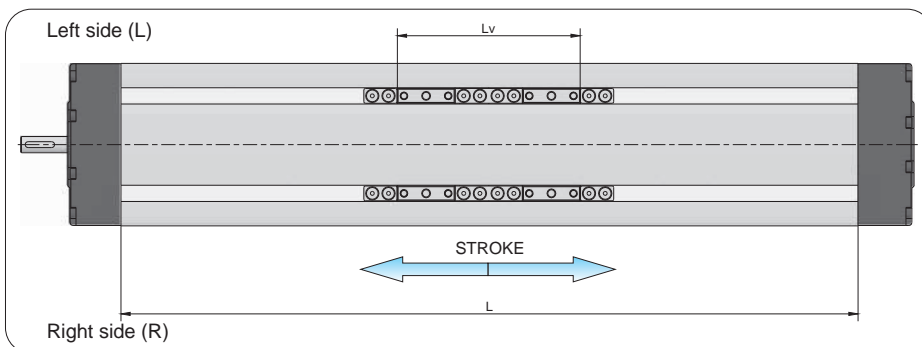

Double-Carriage

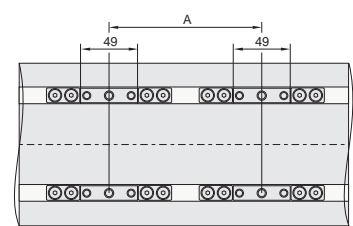

Only with **Short** carriage version.

$L = \text{Effective stroke} + 2 \times \text{Safety travel} + A + 110 \text{ mm}$ } $A \geq 100 \text{ mm}$

For ordering code please contact us.

DIMENSIONS

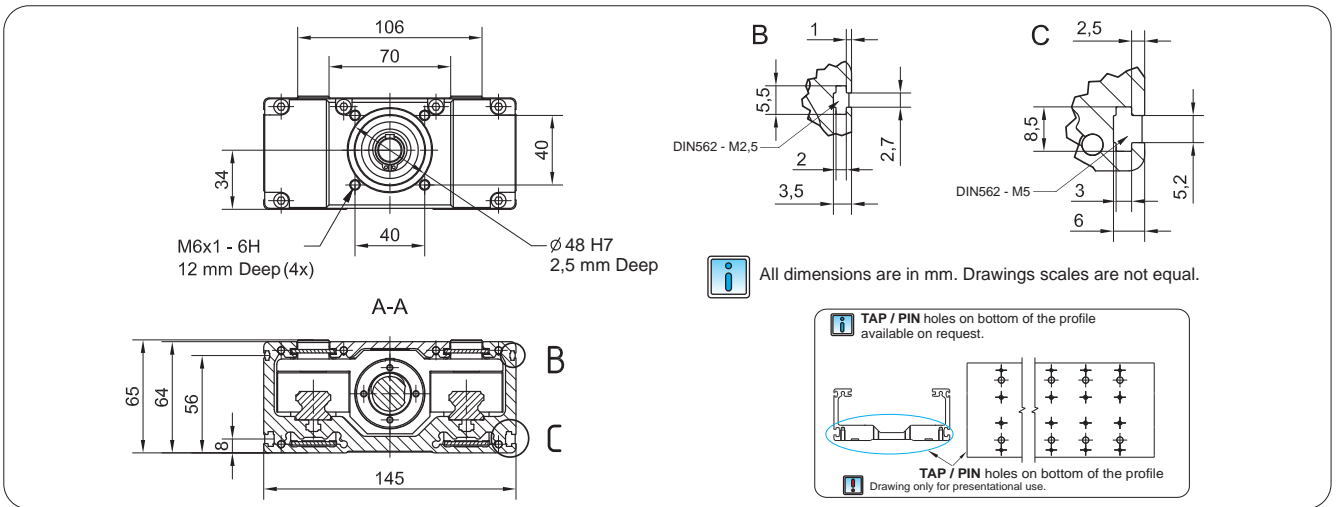

CONNECTION PLATE

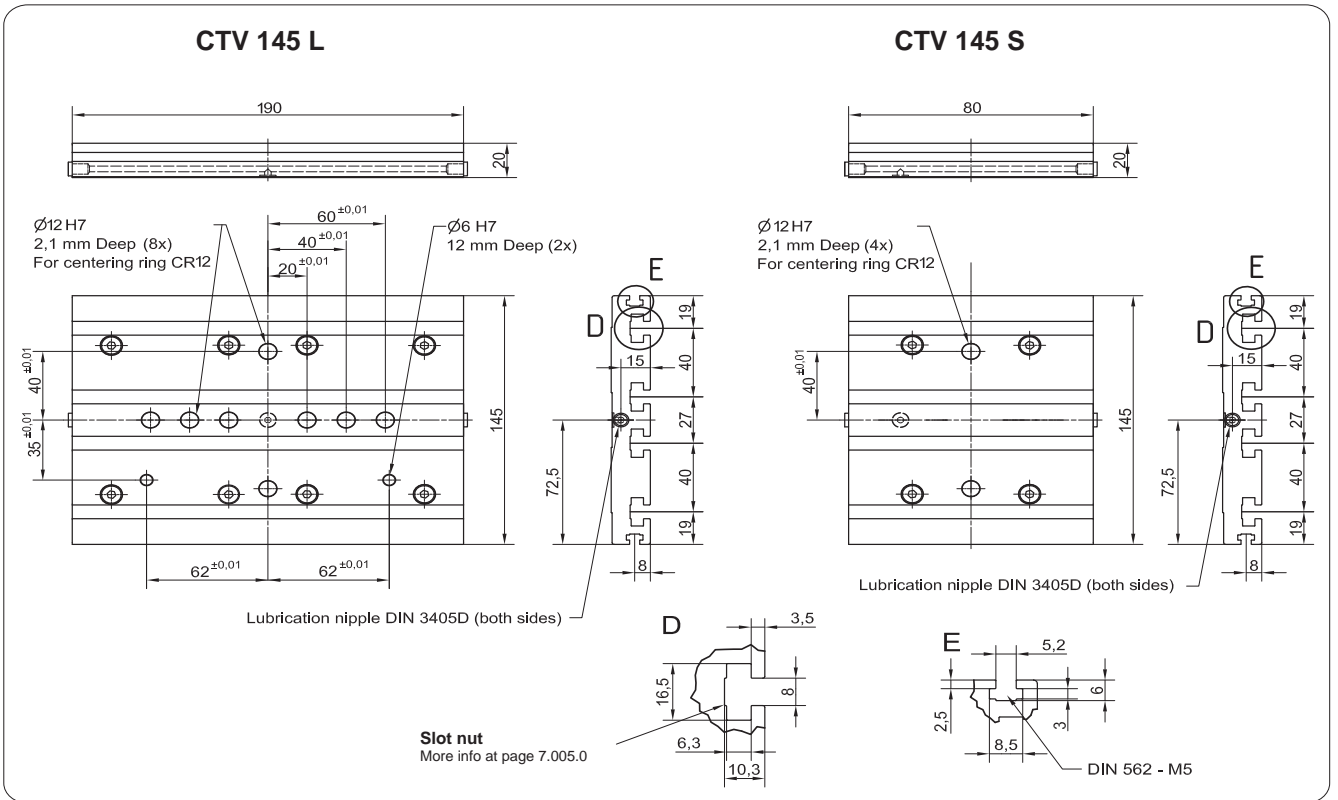

Linear Unit	Plate length [mm]	Weight [kg]	Code
CTV 145 S	80	0,78	48351
CTV 145 L	190	1,54	48350

Mounting elements for mounting the connection plate on the Linear unit are included.

MOTOR - MOTOR SIDE DRIVE

CTV 145

Available on request

MOTOR

CTV 145

Available on request

GEAR REDUCER + MOTOR

CTV 145

Available on request

GEAR REDUCER 90° + MOTOR

CTV 145

Available on request

STRUCTURAL DESIGN

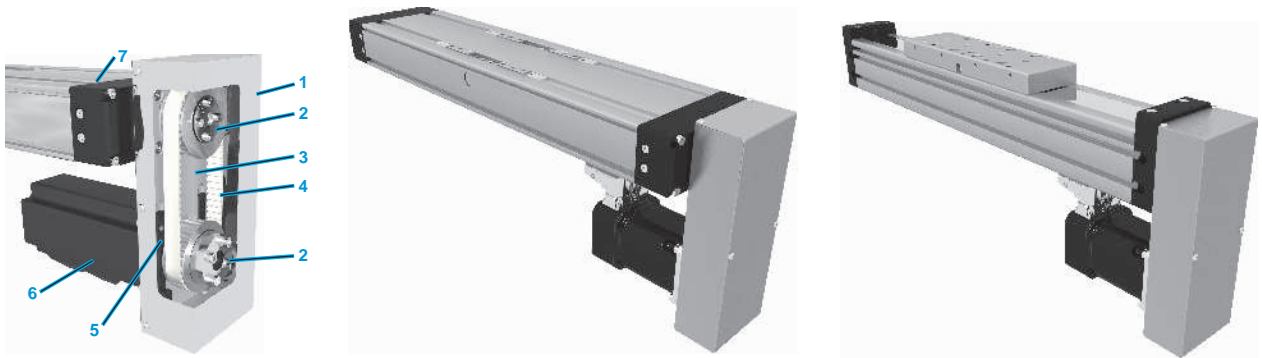

- 1 - Cover / Abdeckung
- 2 - Attachment of pulley with clamping set /
- 3 - Anodized aluminium housing,
- 4 - Toothed belt
- 5 - Belt tensioning system (elongation and frequency of belt span provided with delivery of unit)
- 6 - Motor
- 7 - CTV linear unit

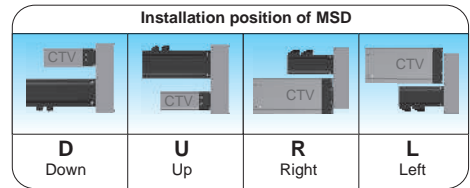

DIMENSIONS AND TECHNICAL DATA

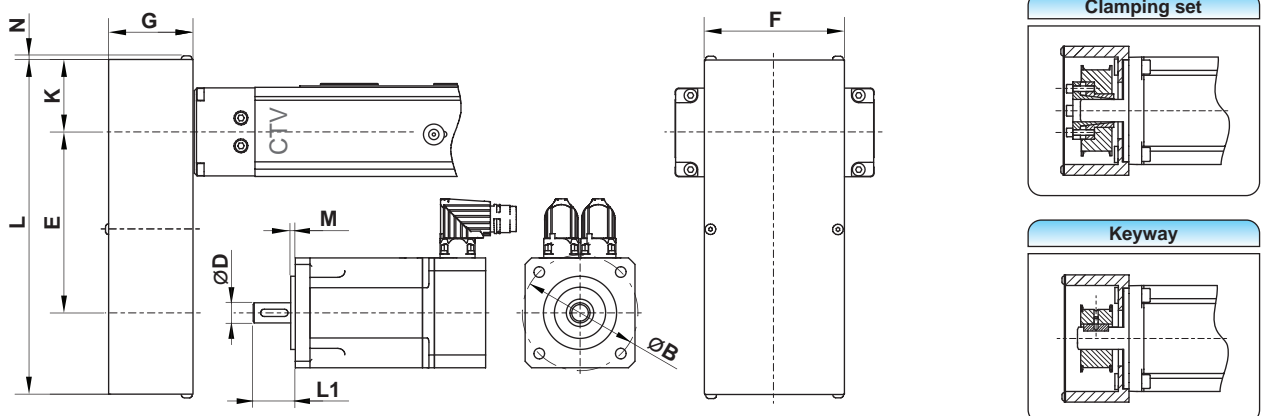

Linear Unit	Type	Gear ratio	Max. drive torque [Nm]	Motor size limits [mm]						Dimensions [mm]						
				ØB max	M max	L1		ØD max		E	F	G	K	L	N	
						Clamping set min	Keyway	max	Clamping set	Keyway						
CTV 90	T1	i=1	4	84	4*	22	25	39	14	22	100	70	41	31	179	2
		i=1,5	4			/			/	14						
CTV 110 / MTV 65	T1	i=1	4	84	4*	22	25	39	14	22	100	70	41	31	179	2
		i=1,5	4			/			/	14					112	
CTV 110 / MTV 65	T2	i=1	9	112	4*	24	30	49	18	30	145	90	51	43	250	2
		i=1,5	9			25			14	139						
CTV 145 / MTV 80	T1	i=1	9	112	4*	24	30	49	18	30	145	90	51	43	250	2
		i=1,5	9			25			14	180	282					
CTV 145 / MTV 80	T2	i=1	12	120	4*	30	35	59	22	40	160	120	61	56	297	2,5
		i=2	12						14	32	158					

*For a bigger value an additional adapter plate is used

HOW TO ORDER

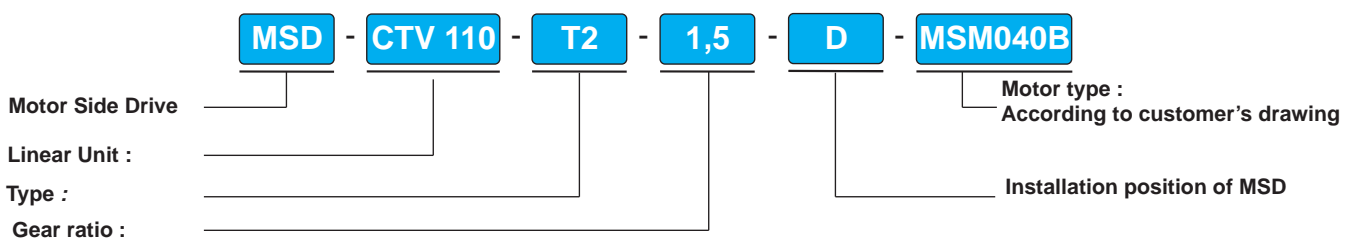

FIXING SYSTEM

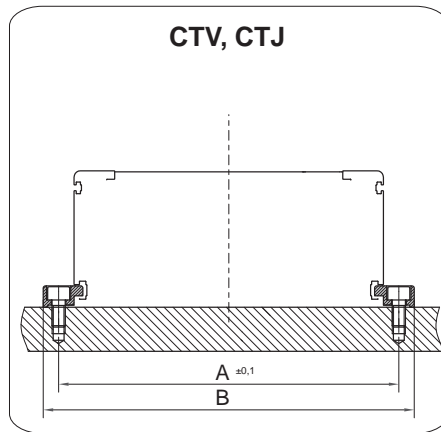
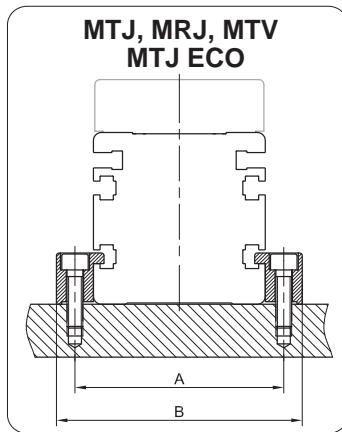

General

The modules are mounted by using fixtures which are placed in the slot on the side of the profile.



Linear Unit must be mounted by the aluminium profile!

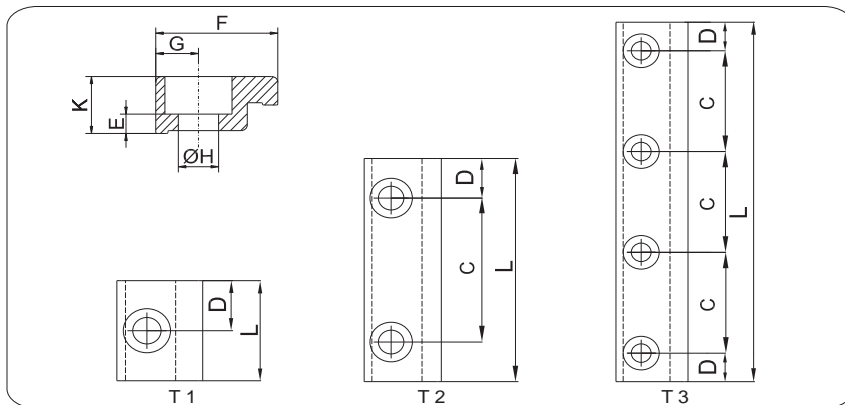

Linear Unit	Type	Dimensions [mm]										Screw	Countersink for	Weight [kg]	Code
		A	B	C	D	L	E	F	G	ØH	K				
MTJ, MRJ 40	T 2	50	64,4	40	7,5	55	2,5	15	7,2	5,5	8	M5	DIN 912	0,014	37139
MTJ, MRJ, MTV 65	T 2	78	93	40	10	60	11,5	20	7,5	6,5	20	M6	DIN 912	0,054	37129
MTJ, MRJ, MTV 80	T 2	93	108	40	10	60	11,5	20	7,5	6,5	20	M6	DIN 912	0,054	37129
MTJ, MRJ 110	T 2	130	150	40	10	60	18	30	10	8,5	27	M8	DIN 912	0,082	44375
MTJ ECO 40	T 2	52	66	40	7,5	55	14,5	20	7	5,5	20	M5	DIN 912	0,035	40728
CTV, CTJ 90	T 1	102	112	/	12,5	25	4,5	15	5	4,5	9	M4	DIN 912	0,01	46994
CTV, CTJ 90	T 2	102	112	40	11	62	4,5	15	5	4,5	9	M4	DIN 912	0,02	48636
CTV, CTJ 90	T 3	102	112	20	8,5	77	4,5	15	5	4,5	9	M4	DIN 912	0,025	47163
CTV, CTJ 90	T 3	102	112	25	6	87	4,5	15	5	4,5	9	M4	DIN912	0,028	55261
CTV, CTJ 90	T 3	102	112	30	8,5	107	4,5	15	5	4,5	9	M4	DIN912	0,031	55638
CTV, CTJ 110	T 1	126	140	/	12,5	25	3,4	20	7	6,6	10	M6	DIN 912	0,01	48642
CTV, CTJ 110	T 2	126	140	40	11	62	3,4	20	7	6,6	10	M6	DIN 912	0,03	48643
CTV, CTJ 110	T 3	126	140	20	8,5	77	4,5	20	7	5,5	10	M5	DIN 912	0,03	48640
CTV, CTJ 110	T 3	126	140	30	8,5	107	4,5	20	7	5,5	10	M5	DIN 912	0,045	46995
CTV, CTJ 110	T 3	126	140	40	11	142	3,4	20	7	6,6	10	M6	DIN912	0,056	55260
CTV, CTJ 145	T 1	161	175	/	12,5	25	4,5	20	7	6,5	10	M6	DIN 912	0,01	48642
CTV, CTJ 145	T 2	161	175	40	11	62	4,5	20	7	6,5	10	M6	DIN 912	0,03	48643
CTV, CTJ 145	T 3	161	175	20	8,5	77	4,5	20	7	5,5	10	M5	DIN 912	0,03	48640
CTV, CTJ 145	T 3	161	175	30	8,5	107	4,5	20	7	5,5	10	M5	DIN 912	0,045	46995
CTV, CTJ 145	T 3	126	140	40	11	142	3,4	20	7	6,6	10	M6	DIN 912	0,056	55260
CTJ 200	T 2	222	240	40	19	78	14,8	29	9	8,5	27,5	M8	DIN 912	0,110	53049
CTJ 200	T 2	222	240	50	19	88	14,8	29	9	8,5	27,5	M8	DIN 912	0,120	53050
CTJ 200	T 2	222	240	70	19	108	16,3	29	9	8,5	27,5	M8	DIN 912	0,160	53051



Recommended number of clamping fixtures: For T1 is recommended 6 pcs. per meter on each side, for T2 is recommended 3 pcs. per meter on each side and for T3 is recommended 3 pcs. per meter on each side.

CENTERING RING

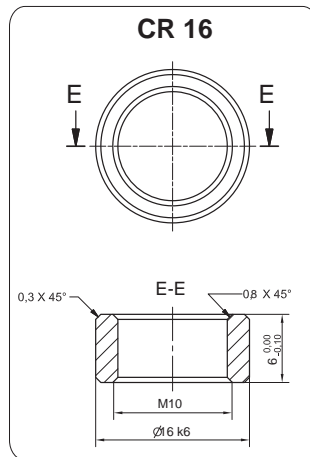
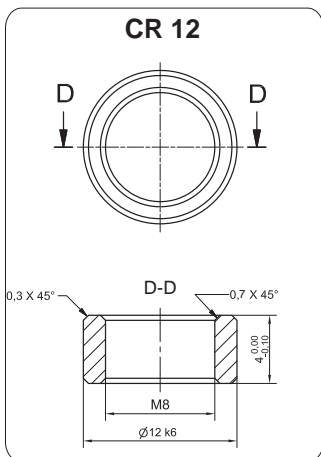
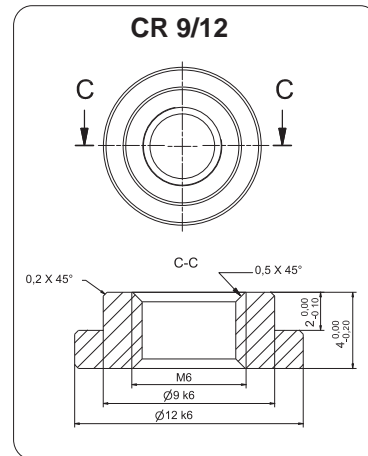
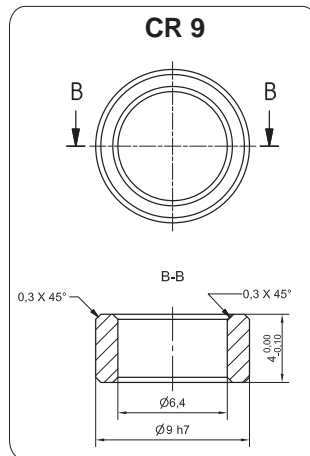
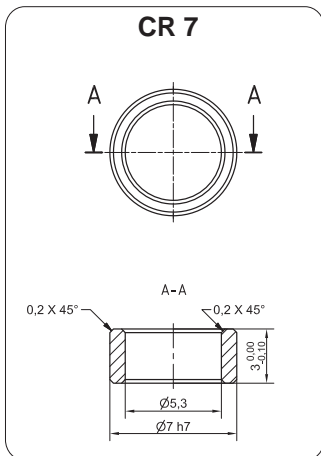

Type	Compatible with	Code
CR 7	MTJ/MRJ/MTJZ/MTV: 40, 65	23332
CR 9	MTJ/MRJ /MTV/MTJZ: 80,110 CTV/CTJ: 90, 110	23331
CR 9/12	MTJ/MRJ /MTV/MTJZ: 80,110 CTV/CTJ: 90, 110, 145	48885
CR 12	CTV/CTJ: 145	49049
CR 16	CTJ 200	53023



SLOT NUTS



DIN562



DIN557



Slot Nut

LINEAR UNITS - PROFILE

CODE	NUT TYPE	MTJ/MRJ 40	MTJ/MRJ/ MTV/MTJZ 65	MTJ/MRJ/ MTV/MTJZ 80	MTJ/MRJ 110	MTJ ECO 40	CTV 90 CTJ 90	CTV 110 CTJ 110	CTV 145 CTJ 145	CTJ 200
41609	DIN562 - M2,5						X	X	X	
40682	DIN562 - M4	X	X	X			X			
40768	DIN562 - M5							X	X	
40769	DIN557 - M5		X	X						
44451	DIN557 - M8				X					
5746	Slot Nut M6					X				
5551	Slot Nut T-10-M8									X
5552	Slot Nut T-10-M6									X
5553	Slot Nut T-10-M5									X
5570	Slot Nut T-10-M8 L=90									X

LINEAR UNITS - CONNECTION PLATES

CODE	NUT TYPE	CTJ 200
5551	Slot Nut T-10-M8	X
5552	Slot Nut T-10-M6	X
5553	Slot Nut T-10-M5	X
5570	Slot Nut T-10-M8 L=90	X

CODE	NUT TYPE	CTV 145 CTJ 145
5704	Slot Nut 8LM4	X
5703	Slot Nut 8LM5	X
5702	Slot Nut 8LM6	X
5701	Slot Nut 8LM8	X

IDENT	NUT TYPE	CTV 110 CTJ 110	CTV 90 CTJ 90
48887	Slot Nut 6LM4	X	X
48888	Slot Nut 6LM5	X	X

MAGNETIC FIELD SENSORS

MTJ / MRJ / MTV

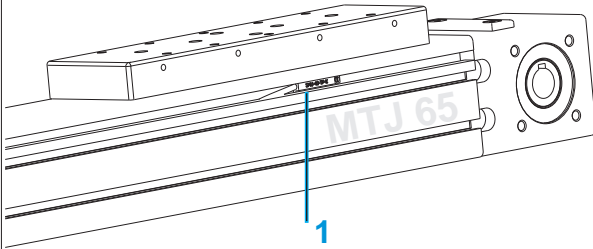

- 1 - Magnetic field sensor
- 2 - Sensor holder

CTV / CTJ

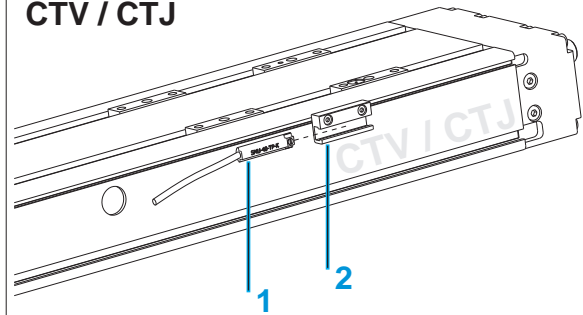

 Mounting of Magnetic field sensor on CTV and CTJ series requires a HOM sensor holder. For CTJ 200 a HOM sensor holder is not needed.

SMU-40TP-K PNP NO

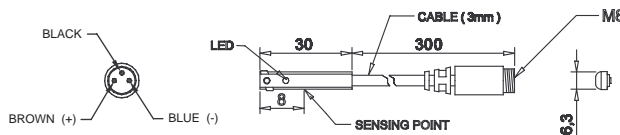

Extension cable with connector

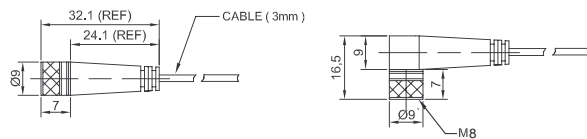

Code	Type	Compatibility	
43851	HOM sensor holder	CTV90, CTV110, CTV145, CTJ90, CTJ110, CTJ145	
40679	SMU-40TP-K	MTJ/MRJ/MTV/MTJZ:40,65,80,110 CTJ: 200	
45869	SMU-40TP-K + HOM	CTV90, CTV110, CTV145 CTJ90, CTJ110, CTJ145	
8146	Extension Cable length 2m - Straight connector		
8147	Extension Cable length 5m - Straight connector		
9017	Extension Cable length 2m - Angeled connector		
9019	Extension Cable length 5m - Angeled connector		

SME-8M-DO PNP NC

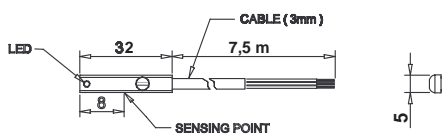

Code	Type	Compatibility	
43851	HOM sensor holder	CTV90, CTV110, CTV145 CTJ90, CTJ110, CTJ145	
43310	SME-8M-DO	MTJ/MRJ/MTV/MTJZ:40,65,80,110 CTJ: 200	
45870	SME-8M-DO + HOM	CTV90, CTV110, CTV145 CTJ90, CTJ110, CTJ145	

TECHNICAL DATA

SMU-40TP-K PNP NO

SME-8M PNP NC

Sensor Type	PNP	Contacting, Bipolar
Switching function	NO	NC
Operating voltage	10 ~ 30 V DC	5 ~ 30 V DC
Switching Current	100 mA max.	80 mA max.
Switching capacity	6 W max.	2,4 W max.
Voltage Drop	1,5 V max.	3,5 V max.
Current Consumption	20 mA / 24 V DC max.	20 mA / 24 V DC max.
Switching Frequency	1000 Hz	/
Ambient temperature	-10 do +70°C	-10 do +70°C
Shock/Vibration	50 G / 9 G	50 G / 9 G
Protection class	IP 67	IP 65, IP 67
LED indicator	Yellow	Yellow
Electrical connection	M8, 3-pin	Open end
Cable material-length	PU - 0,3 m	PU- 7,5 m
	/	Energy chain compliant-bending radius 75 mm

Extension cable

Energy chain compliant

/

MTJ / MRJ / MTV

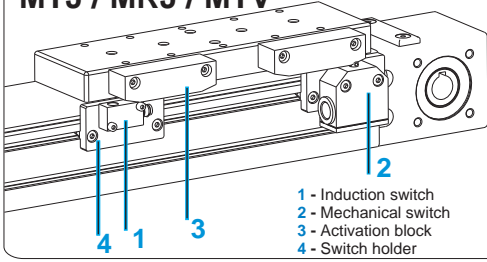

CTV / CTJ

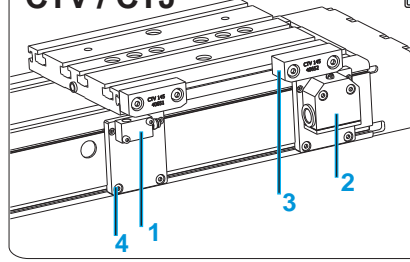

i Mounting and using the Induction and Mechanical switch, can be done only if the CTV and CTJ series Linear Units are delivered with Connection plates.

MS- Mechanical switch

TECHNICAL DATA

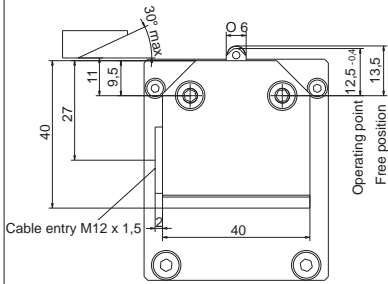

Protection class IEC 60529	IP 67
Ambient temperature	-5°C ...+80°C
Operating point accuracy	± 0.05 mm
Approach speed max.	45 m/min
Approach speed min.	0,01 m/min
Switching contact	1 changeover
Switching principle	Snap-action
Rated voltage	250 V AC
Switching current, min. at	10 mA
Switching voltage	24 V DC
Cable entry	M12 x 1,5

ORDERING CODES

	MTJ/MRJ/ MTJZ 40	MTJ/MRJ/ MTJZ/MTV 65	MTJ/MRJ/ MTJZ/MTV 80	MTJ/MRJ 110	MTJ ECO 40	CTV/CTJ 90	CTV/CTJ 110	CTV/CTJ 145	CTJ 200
+ 2x Activation block with fixing screws	43243	43247	43256	47827	49030	49032	49031	40652	40652
Mechanical switch only	47921								
2x + 2x + Mechanical switch with mounting elements	40683	40687	40689	47826	49035	49034	49033	47939	53055

IS- Inductive switch

TECHNICAL DATA

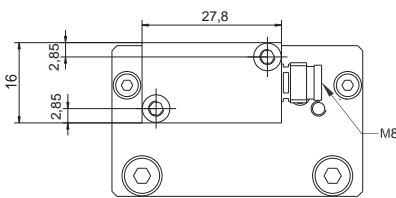

Sensor Type	PNP
Switching function	NC / NO
Rated voltage	10 ~ 30 V DC
Switching Current	150 mA max.
Ambient temperature	-25°C ...+70°C
Switching Frequency	800 Hz max.
Voltage Drop	3,5 V
Protection class	IP 67
Electrical connection	M8, 3-pin
Extension cable	Energy chain compliant - bending radius 75 mm
Cable material-length	PU
Cable length	2m / 5m
Cable length	M8, 3-pin Straight or Angeled connector

Extension cable with connector

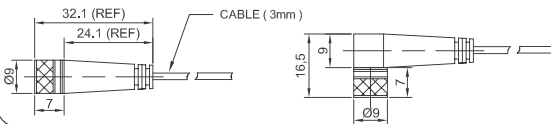

ORDERING CODES

	MTJ/MRJ/ MTJZ 40	MTJ/MRJ/ MTJZ/MTV 65	MTJ/MRJ/ MTJZ/MTV 80	MTJ/MRJ 110	MTJ ECO 40	CTV/CTJ 90	CTV/CTJ 110	CTV/CTJ 145	CTJ 200
+ 2x Activation block with fixing screws	43243	43247	43256	47827	49030	49032	49031	40652	40652
PNP NO Inductive switch only	40671								
2x + 2x + PNP NO Ind. switch with mounting elements	40680	48026	43233	48047	45105	49039	49038	48058	53054
PNP NC Inductive switch only	43570								
2x + 2x + PNP NC Ind. switch with mounting elements	48851	40685	47848	47989	45103	49037	49036	47850	53052
Extension Cable length 2m - Straight connector							8146		
Extension Cable length 5m - Straight connector							8147		
Extension Cable length 2m - Angeled connector							9017		
Extension Cable length 5m - Angeled connector							9019		

MOTOR ADAPTER WITH COUPLING

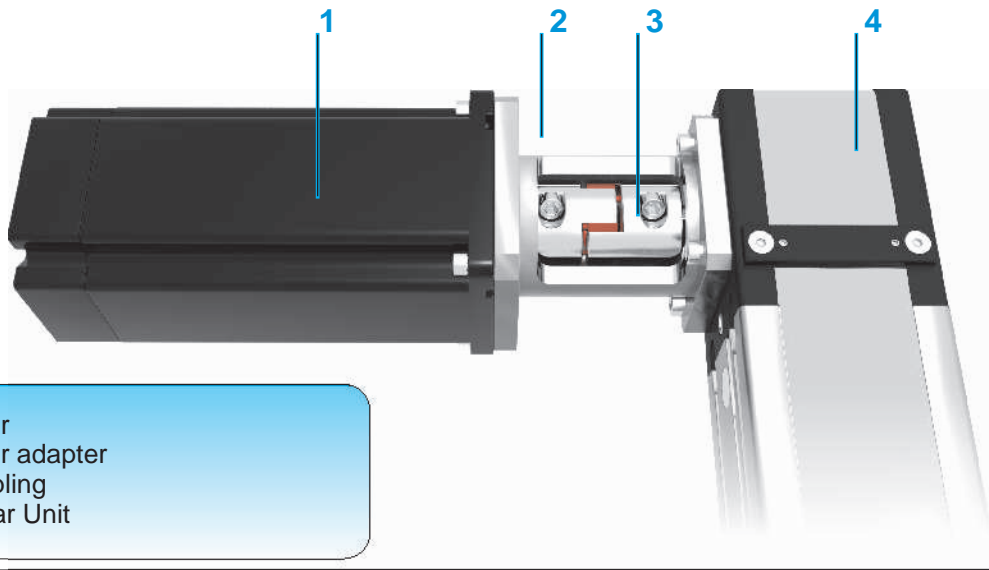

- 1 - Motor
- 2 - Motor adapter
- 3 - Coupling
- 4 - Linear Unit

VK - CTV 110 - SMB60 - GESM14

Motor adapter : _____

Linear Unit : _____

Motor type : _____

According to customer's specification

Coupling type : _____

See page 7.020.0 or According to customer's specification

COUPLINGS

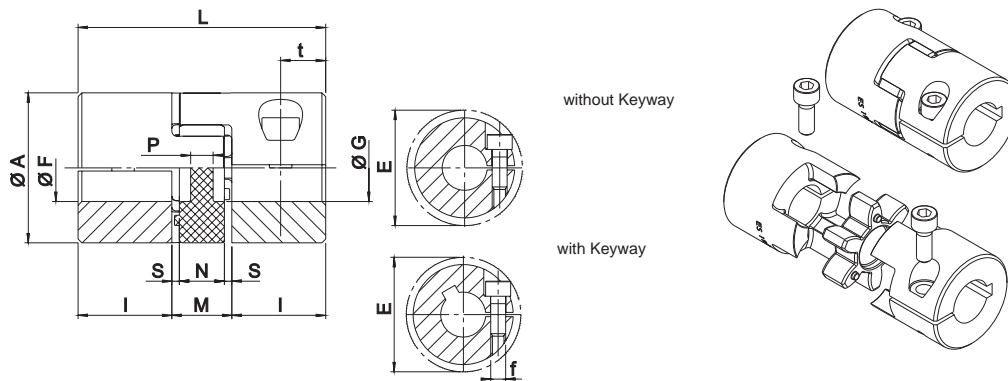

Size	* T _{KN} Nominal (Nm)	* T _{Kmax} (Nm)	M _s (Nm)	Hub		n _{max} (min ⁻¹)	A (mm)	G (mm)	L (mm)	I (mm)	M (mm)	N (mm)	S (mm)	P (mm)	t (mm)	E (mm)
				W (Kg)	J (Kg ^{m²})											
7	2	4	0,35	0,003	0,085 x 10 ⁻⁶	40.000	14	-	22	7	8	6	1,0	6	4	15,0
9	5	10	0,75	0,007	0,42 x 10 ⁻⁶	28.000	20	7,2	30	10	10	8	1,0	2	5	23,4
14	12,5	25	1,4	0,018	2,6 x 10 ⁻⁶	19.000	30	10,5	35	11	13	10	1,5	2	5,5	32,2
19/24	17	34	11	0,071	18,1 x 10 ⁻⁶	14.000	40	18	66	25	16	12	2,0	3,5	12	45,7
24/28	60	120	11	0,156	74,9 x 10 ⁻⁶	10.600	55	27	78	30	18	14	2,0	4	12	56,4
28/38	160	320	25	0,240	163,9 x 10 ⁻⁶	8.500	65	30	90	35	20	15	2,5	5,2	13,5	72,6
38/45	325	650	25	0,440	465,5 x 10 ⁻⁶	7.100	80	38	114	45	24	18	3,0	5,6	16	83,3

* The values of nominal T_{KN} and max. T_{Kmax} transmissible torque in the upper table are valid for coupling with Keyway!



Size	Recommended coupling bore diam. and Transmissible Torque (Nm) - valid for shaft tolerances k6 without Keyway																									
	o4	o5	o6	o7	o8	o9	o10	o11	o12	o14	o15	o16	o19	o20	o22	o24	o25	o28	o30	o32	o35	o38	o40	o42	o45	
7	0,7	0,8	1	1,1																						
9	1,1	1,4	1,7	1,9	2,2	2,5	2,8	3																		
14			2,5	2,9	3,3	3,7	4,1	4,6	5	5,8	6,2	6,6														
19/24								23	25	27	32	34	36	43	45											
24/28								23	25	27	32	34	36	43	45	50	54	57	63							
28/38											58	62	66	79	83	91	100	104	116	124	133	145				
38/45												62	66	79	83	91	100	104	116	124	133	145	158	166	174	187

- Ms** Screw tightening torque Nm
- W** Weight Kg
- J** Coupling moment of inertia kgm^2
- n_{max}** Maximum rpm min^{-1}
- T_{KN}** Coupling nominal torque Nm
- T_{kmax}** Coupling maximum torque Nm

The operating temperature range for the coupling is between -30 and +90°C

SYNCHRONISATION SHAFT OSL

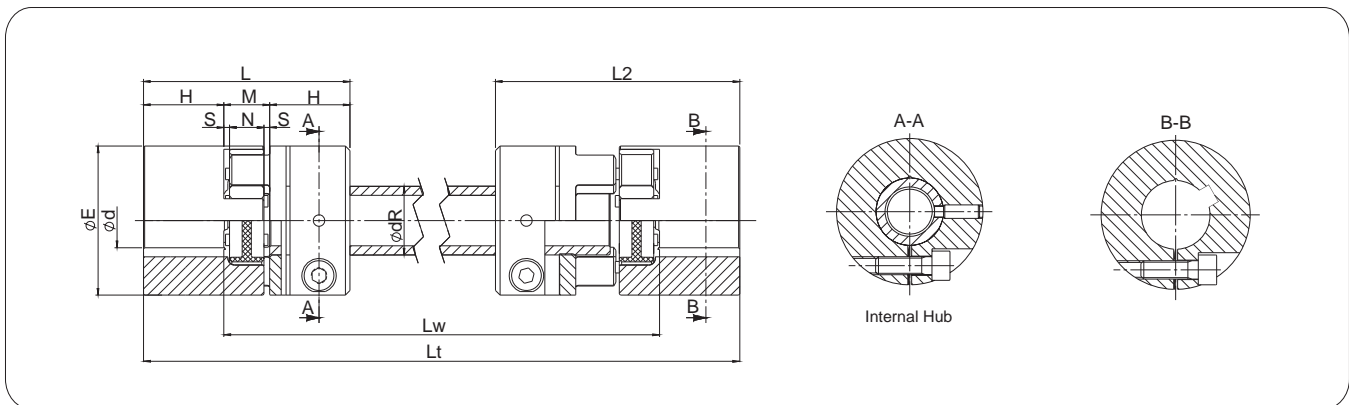

Size	Internal Hub		E (mm)	H (mm)	ød min (mm)	ød max (mm)	M (mm)	N (mm)	S (mm)	L (mm)	L2 (mm)	Lw min (mm)	Lt (mm)	dR x thickness (mm)
	Ms (Nm)	Mt (Nm)												
14	1,4	6	30	11	4	16	13	10	1,5	35	48	71		14 x 2,0
19/24	10	35	40	25	6	24	16	12	2	66	82	110	on Request	20 x 3,0
24/28	10	45	55	30	8	28	18	14	2	78	96	128		25 x 2,5
28/38	25	108	65	35	10	38	20	15	2,5	90	110	145		35 x 4,0
38/45	25	125	80	45	12	45	24	18	3	114	138	180		40 x 4,0

- Ms** Screw tightening torque Nm
- Mt** Maximum transmissible torque Nm

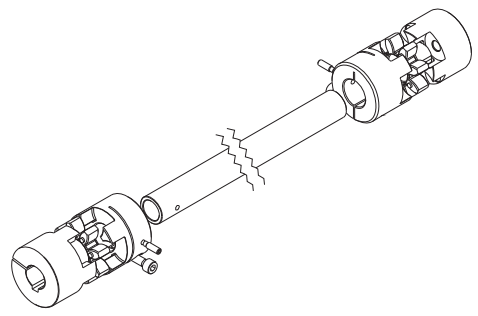
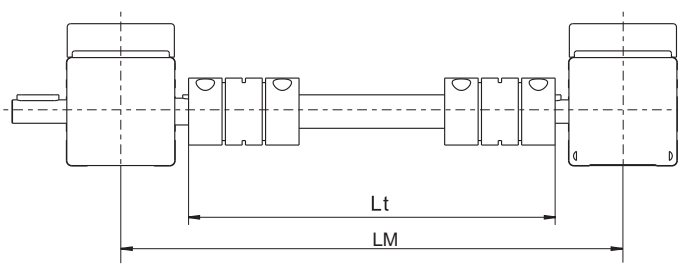

For longer distances Bearing Supports needed. Please contact us.

SYNCHRONISATION SHAFT OSR

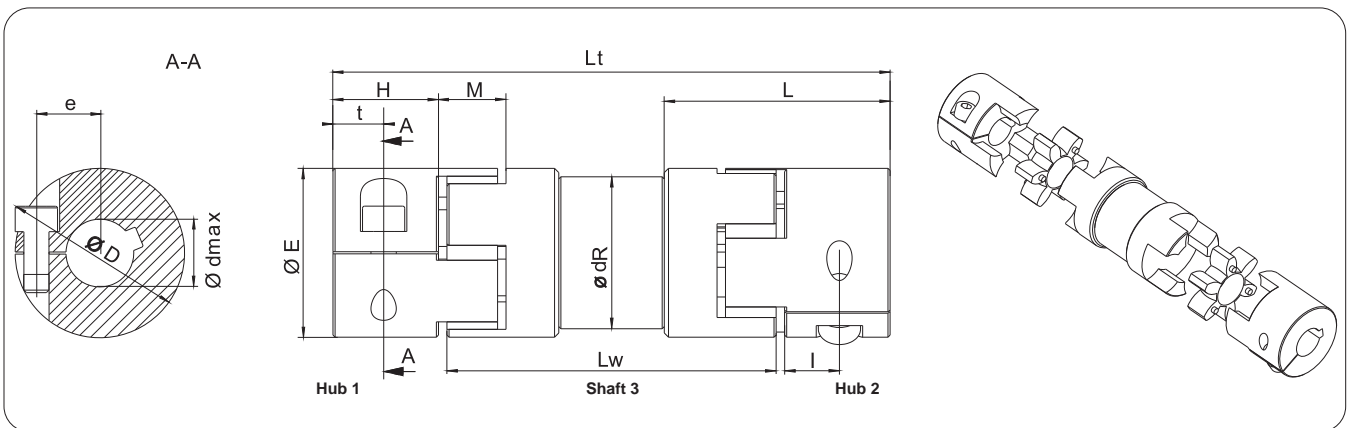

Size	d min (mm)	d max (mm)	Ms (Nm)	Moment of inertia (10 ⁴ kgm ²) with d _{max} hub1			C _T (Nm/rad)	E (mm)	H (mm)	I (mm)	L (mm)	M (mm)	Lw min (mm)	LT (mm)	D (mm)	t (mm)	e (mm)	dR (mm)
				Hub 1 J ₁	Hub 2 J ₂	Shaft 3 J ₃												
19	10	20	10	0,02002	0,01304	0,340	3003	40	25	13	53,5	16	78	on request	47	12	15	36
24	10	28	10	0,07625	0,04481	0,0697	639	55	30	16	63	18	92		57	14	20,8	45
28	14	35	25	0,17629	0,1095	1,243	10936	65	35	20	67	20	131		73	15	25	60
38	15	45	25	0,50385	0,2572	3,072	27114	80	45	33	83,5	24	163		84	15,5	30	70

- Ms** Screw tightening torque Nm
- CT** Torsional rigidity Nm/rad
- J** Coupling moment of inertia kgm²

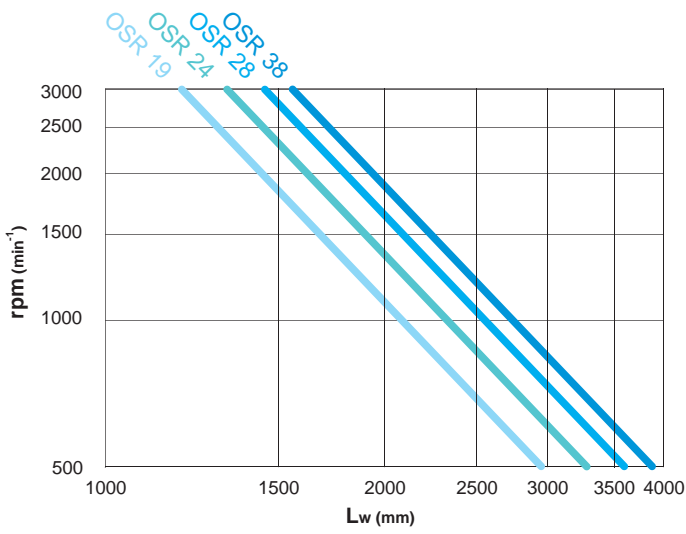

← SELECTION DIAGRAM

Ideal execution for long distance shat connections.
Torque transmission is zero backlash. Designed for length up to 4 m without bearing support (depending on rotation speed).

HOW TO ORDER

OSR - 19 - MTJ65 - 890

- Type : _____
- OSL, OSR
- Size : _____
- OSL; 14, 19/24, 24/28, 28/38, 38/45
- OSR; 19, 24, 28, 38
- Linear unit series : _____
- MTJ/MRJ 40, MTJ/MRJ 65, MTJ/MRJ 80, MTJ/MRJ 110, MTJ ECO 40,
- CTJ 90, CTJ 110, CTJ 145, CTJ 200
- Without : not for linear units
- Distance LM for applications with Linear units : _____
- Distance LT for applications without Linear units : _____

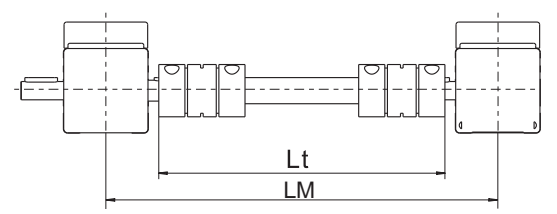

The specifications in order to improve the products in this catalogue are subject to change without notice.

X-Y CONNECTION ELEMENTS

X- Axis MTJ, MRJ, MTV, MTJ ECO, CTV = 0° → Y Axis = 0°

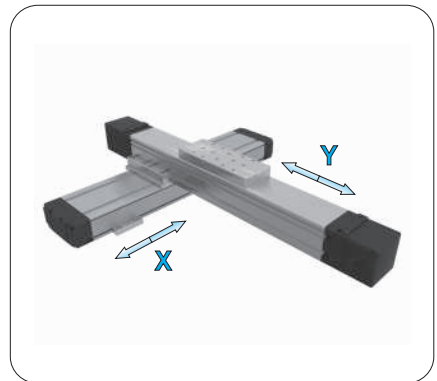
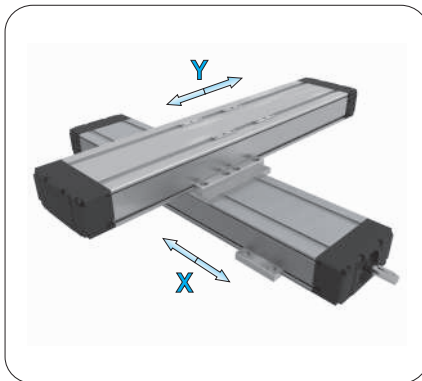
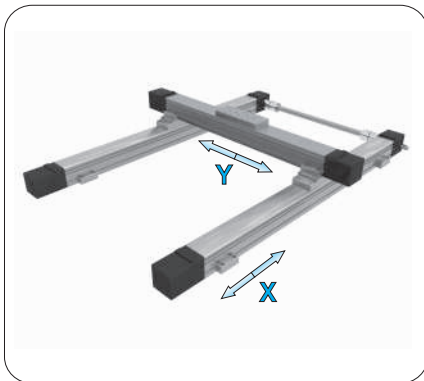

X-Axis	Y-Axis						
	MTJ, MRJ 40	MTJ, MRJ, MTV 65	MTJ, MRJ, MTV 80	MTJ, MRJ 110	MTJ 40 ECO	CTV 110	CTV 145
MTJ, MRJ 40	CP M40 0 M40 0	CP M40 0 M65 0	CP M40 0 M80 0		CP M40 0 E40 0		
MTJ, MRJ, MTV 65	CP M65 0 M40 0	CP M65 0 M65 0	CP M65 0 M80 0	CP M65 0 M110 0		CP M65 0 C110 0	
MTJ, MRJ 80		CP M80 0 M65 0	CP M80 0 M80 0	CP M80 0 M110 0		CP M80 0 C110 0	CP M80 0 C145 0
MTJ, MRJ 110		CP M110 0 M65 0	CP M110 0 M80 0	CP M110 0 M110 0		CP M110 0 C110 0	CP M110 0 C145 0
MTJ 40 ECO	CP E40 0 M40 0	CP E40 0 M65 0	CP E40 0 M80 0		CP E40 0 E40 0	CP E40 0 C110 0	
CTV 110	CP C110 0 M40 0	CP C110 0 M65 0	CP C110 0 M80 0			CP C110 0 C110 0	CP C110 0 C145 0
CTV 145		CP C145 0 M65 0	CP C145 0 M80 0	CP C145 0 M110 0		CP C145 0 C110 0	CP C145 0 C145 0

X- Axis MTJ, MRJ, MTV, MTJ ECO, CTV = 0° → Y Axis = 90°

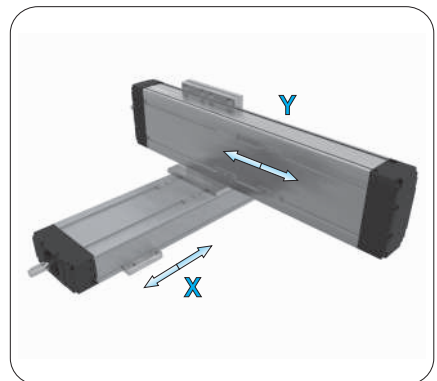
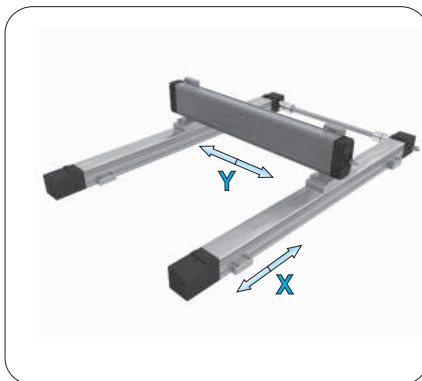
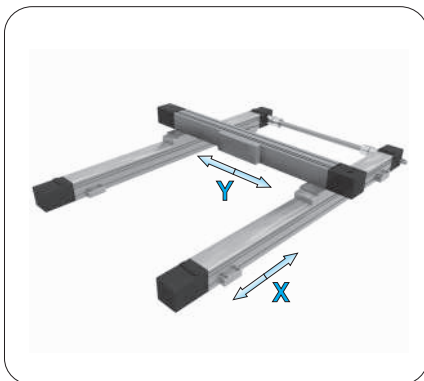

X-Axis	Y-Axis						
	MTJ, MRJ 40	MTJ, MRJ, MTV 65	MTJ, MRJ, MTV 80	MTJ, MRJ 110	MTJ 40 ECO	CTV 110	CTV 145
MTJ, MRJ 40	CP M40 0 M40 90	CP M40 0 M65 90	CP M40 0 M80 90		CP M40 0 E40 0		
MTJ, MRJ, MTV 65	CP M65 0 M40 90	CP M65 0 M65 90	CP M65 0 M80 90	CP M65 0 M110 90		CP M65 0 C110 90	
MTJ, MRJ 80		CP M80 0 M65 90	CP M80 0 M80 90	CP M80 0 M110 90		CP M80 0 C110 90	CP M80 0 C145 90
MTJ, MRJ 110		CP M110 0 M65 90	CP M110 0 M80 90	CP M110 0 M110 90		CP M110 0 C110 90	CP M110 0 C145 90
MTJ 40 ECO	CP E40 0 M40 90	CP E40 0 M65 90	CP E40 0 M80 90		CP E40 0 E40 90	CP E40 0 C110 90	
CTV 110	CP C110 0 M40 90	CP C110 0 M65 90	CP C110 0 M80 90			CP C110 0 C110 90	CP C110 0 C145 90
CTV 145		CP C145 0 M65 90	CP C145 0 M80 90	CP C145 0 M110 90		CP C145 0 C110 90	CP C145 0 C145 90

X-Y CONNECTION ELEMENTS

Y-Axis MTJ, MRJ, MTV, MTJ ECO, CTV = 0° → Z-Axis = 90°

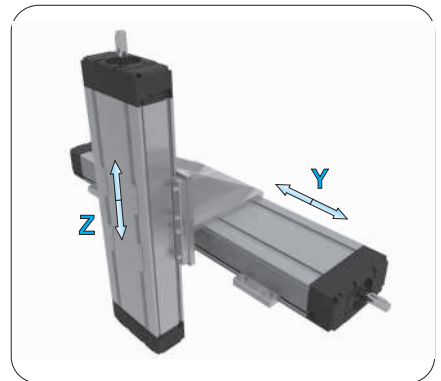
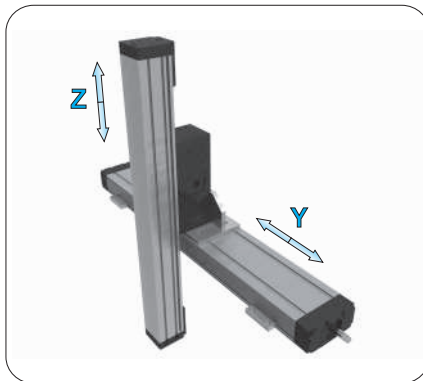
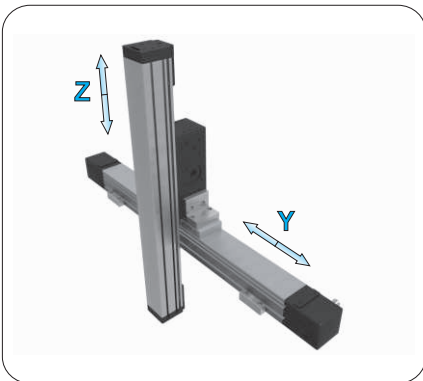

Y-Axis	Z-Axis						
	MTJZ 40	MTJZ65	MTJZ80	MTV65	MTV80	CTV 110	CTV 145
MTJ, MRJ 40	CP M40 0 Z40 90						
MTJ, MRJ, MTV 65	CP M65 0 Z40 90	CP M65 0 Z65 90		CP M65 0 ZM65 90			
MTJ, MRJ 80		CP M80 0 Z65 90	CP M80 0 Z80 90	CP M80 0 ZM65 90	CP M80 0 ZM80 90		
MTJ, MRJ 110		CP M110 0 Z65 90	CP M110 0 Z80 90	CP M110 0 ZM65 90	CP M110 0 ZM80 90		
MTJ 40 ECO	CP E40 0 Z40 90						
CTV 110		CP C110 0 Z65 90	CP C110 0 Z80 90	CP C110 0 ZM65 90	CP C110 0 ZM80 90	CP C110 0 ZC110 90	
CTV 145		CP C145 0 Z65 90	CP C145 0 Z80 90	CP C145 0 ZM65 90	CP C145 0 ZM80 90	CP C145 0 ZC110 90	CP C145 0 ZC145 90

CONNECTION ELEMENTS FOR CUNSTRUCTIONS WITH ALU PROFILES

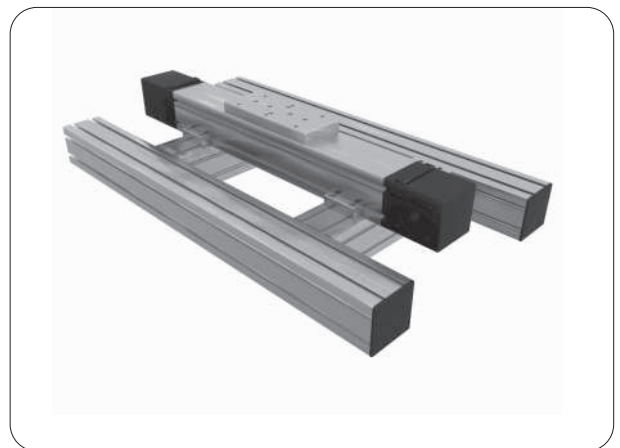
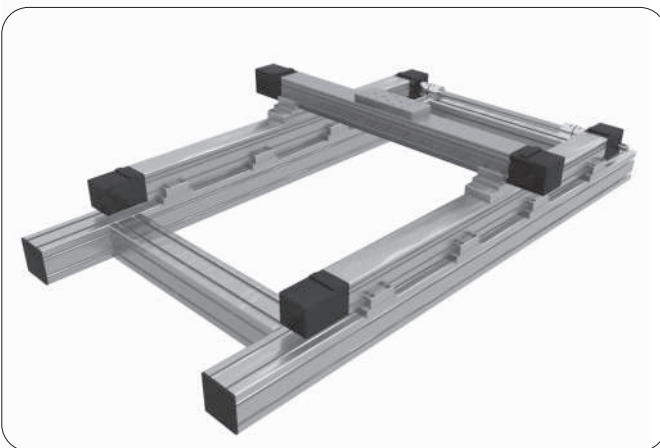

Linear Unit must be mounted by the aluminium profile and not at the end blocks!

For more details about Alu profiles see PROFILE TECHNIC catalogue.

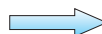

MULTI-AXIS SYSTEMS

We offer all necessary fittings including brackets, clamping fixtures and adapter plates in order to build multi-axis systems. Beside standard elements we supply also custom fixing and connection elements manufactured in our workshop.

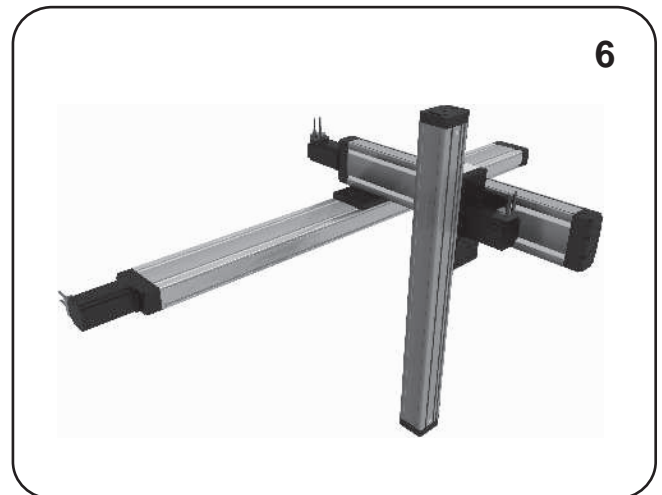
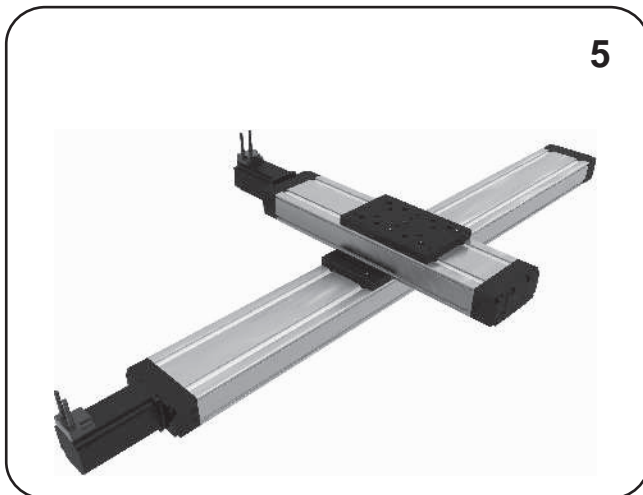
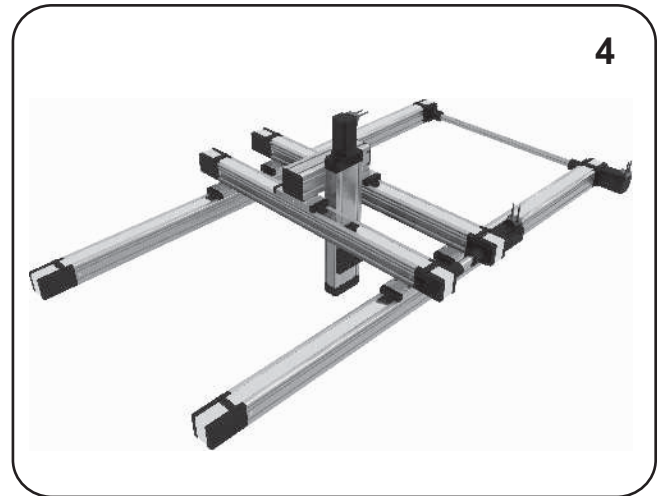
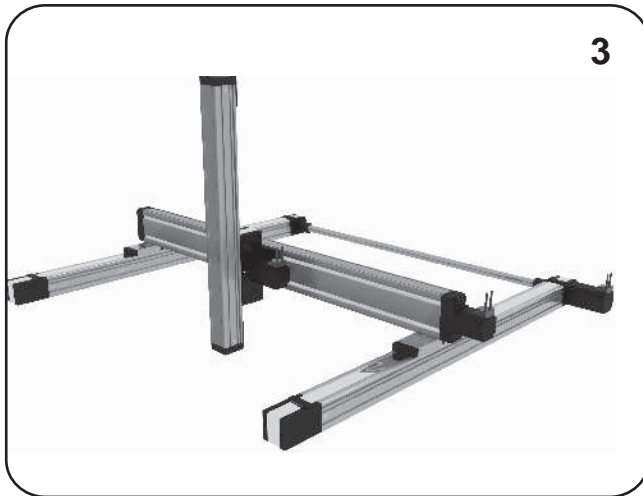
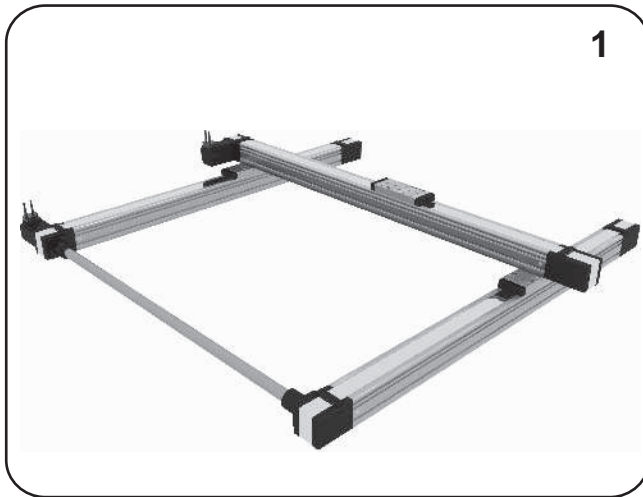

MULTI-AXIS SYSTEMS

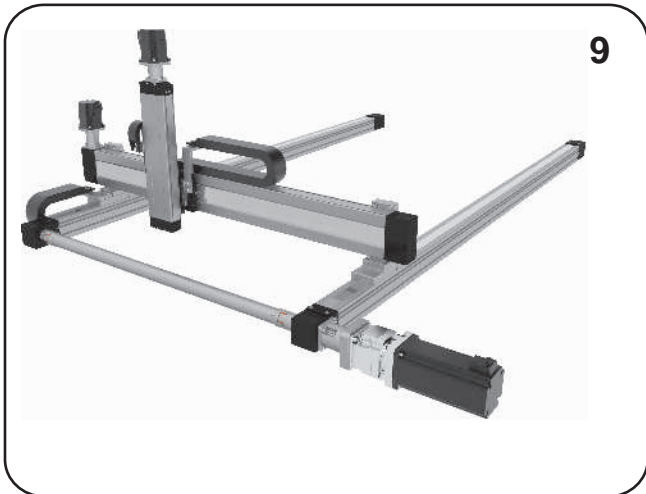
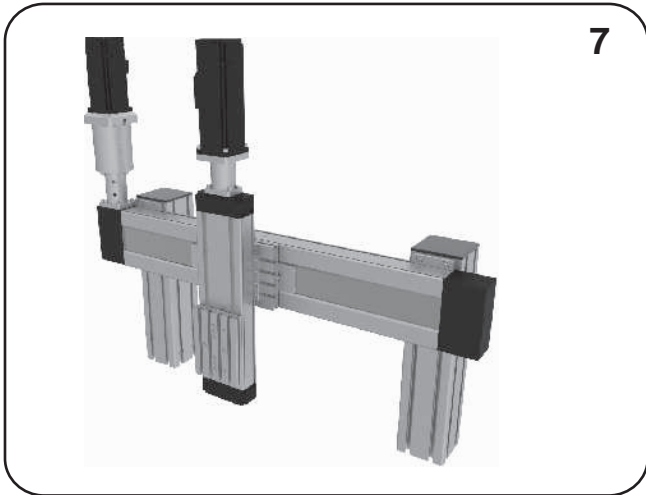

Notes

The calculation program "LINEAR UNITS SELECTION" enables fast and simple selection of a suitable linear axis based on your application data. As a result of the interpretation of this data, the program provides you with diverse information, e.g. driving torque, rotation speed, maximal process speed, durability and other information about a particular product. So contact us!

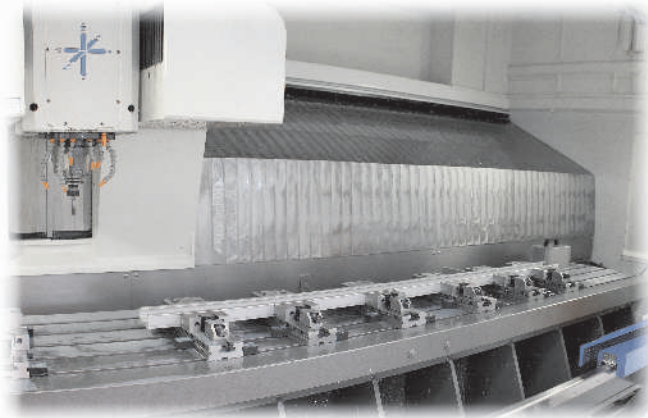

Our modern machinery, for example, comprises several CNC automatic lathes with power tools, a 4-axis machining centre with a highly modern, fully automated pallet changing system and a CNC machining centre with a travel distance of 3.5m, where our linear-axis profiles are machined.

Wenzel's 6m-long measuring machine enables precise control of straightness, parallelism, angle tolerance and other dimensional tolerances of linear axis profiles, before and after processing, as well as the creation of measurement protocols. Our diverse manufactured components can also be measured here.



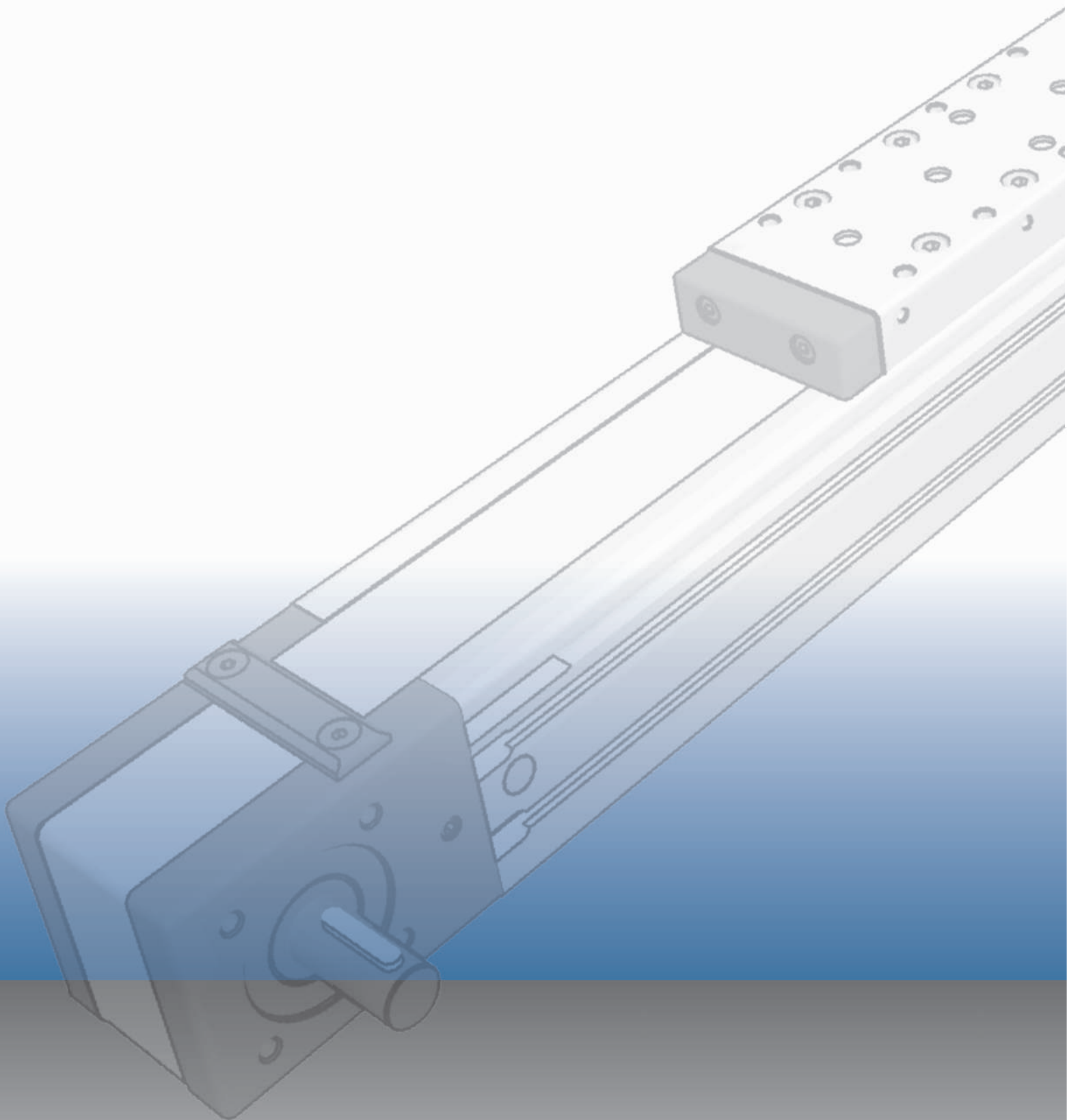

UNIMOTION

Hypex d.o.o.
Alpska cesta 43, 4248 Lesce
Slovenija

Tel: +386 (0)4 5318700 Fax: +386 (0)4 5318740
www.unimotion.eu email: sales@unimotion.eu