

	Parameter	Remarks	Symbol	Unit	UC3	UC6
Performance	Motortype, max voltage ph-ph				3-phase synchronous Ironless, 60V _{dc}	
	Peak Force @ 20°C/s	magnet @ 25°C	F _p	N	36	72
	Continuous Force*	coils @ 80°C	F _c	N	10	20
	Maximum Speed**	@ 60 V	v _{max}	m/s	5	5
	Motor Force Constant	coils @ 25°C	K	N/A _{rms}	11.4	11.4
	Motor Constant	coils @ 25°C	S	N ² /W	9.2	18.3
Electrical	Peak Current	magnet @ 25°C	I _p	A _{rms}	3.1	6.2
	Maximum Continuous Current	coils @ 80°C	I _c	A _{rms}	0.87	1.75
	Back EMF Phase-Phase _{peak}		B _{emf}	V / m/s	9.3	9.3
	Resistance per Phase	coils @ 25°C ex. cable	R _f	Ω	4.7	2.4
	Induction per Phase	I < 0.6 I _p	L _f	mH	0.75	0.38
	Electrical Time Constant	coils @ 25°C	τ _e	ms	0.16	0.16
Thermal	Maximum Continuous Power Loss	all coils	P _c	W	13	26
	Thermal Resistance		R _{th}	°C/W	3.6	1.8
	Thermal Time Constant	minimum	τ _{th}	s	25	25
	Temperature Sensors				none	none
Mechanical	Coil Unit Weight	ex. cables	M	kg	0.031	0.062
	Coil Unit Length	ex. cables	L	mm	34	67
	Motor Attraction Force		F _a	N	0	0
	Magnet Pitch NN		τ	mm	16.5	16.5
	Cable Weight		m	gr/m	7.0	7.0
	Cable Type (Power)	length 1 m	d	mm (AWG)	4.3 (24)	
	Cable Type (Sensor)				N/A	
	Cable Life (Power FLEX)	minimum			15,000,000 cycles	
	Bending Radius Static	minimum			5x cable diameter	
	Bending Radius Dynamic	minimum			8x cable diameter	

*Max. continuous force depends on the thermal resistance, cooling surface and ambient temperature of your application. Download our simulation tool to check the motor's thermal behavior in the application.

** Actual values depend on bus voltage. Please check the F/V diagram in our simulation tool.

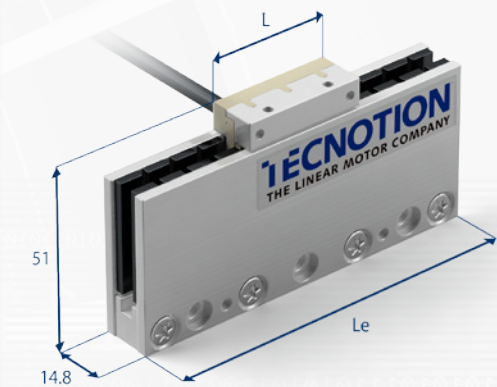

UC3 in 99mm magnet yoke shown

Magnet yoke dimensions			
Le (mm)	66	99	264
M4 bolts	2	3	8
Mass (kg/m)	3.2		
Magnet yokes can be butted together.			

All specifications ±10%

Mounting instructions and flatness or parallelism requirements can be found in the Ironless installation manual. CAD files and 3D models can be downloaded from our website.

MAGNET YOKES

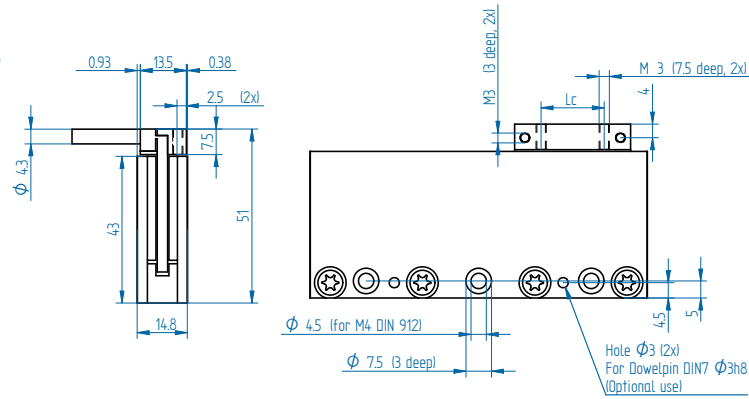

UC 66mm

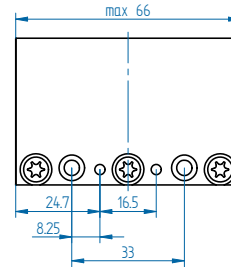

2x UC 99mm

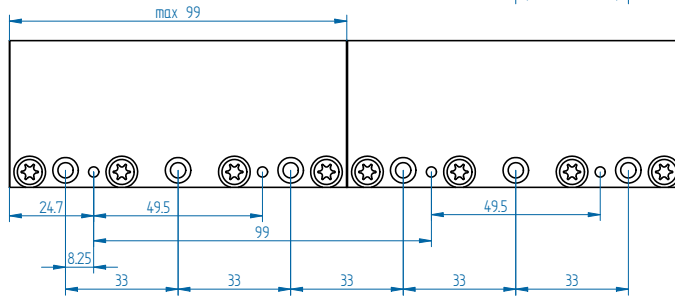

UC 264mm

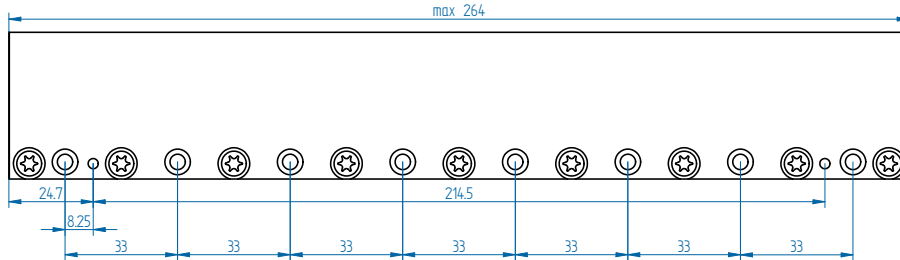

COIL UNITS

	Dig. Hall cable (mm)	Lc (mm)
UC3	Ø3.2	18.5
UC6	Ø3.2	51.5

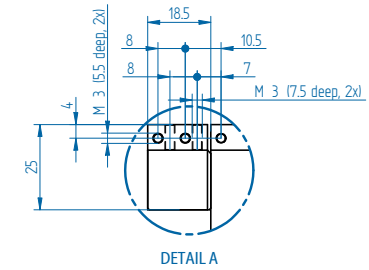

DETAIL A

UC3

Optional: Digital Hall Module

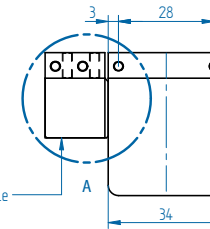

UC6

