

I Series Linear Actuators

Exlar I Series

Exlar I Series™ actuators present a new range of alternatives for linear motion solutions. The I Series actuators offer all of the benefits of Exlar's planetary roller screw technology, along with extreme flexibility in actuator mounting style, and the type of motor used to drive the actuator.

Exlar's roller screw technology has been the integral component in creating the most reliable, long lasting electromechanical actuators on the market. Over the last 15 years, Exlar's inverted roller screw actuators have provided a long-life, all-electric replacement for hydraulic cylinders in thousands of applications.

The I Series actuators offer this same technology in a series of actuators that are economical and allow the use of lower cost motor technology.

Two Models to Fit Your Needs

Two product performance levels are available, so you can choose which option best suits your application and budgetary requirements. The IM Series offers Exlar's standard capacity inverted roller screw in actuators with up to 5 times the travel life of ball screw actuators. The IX Series offers the same load carrying capacity as the IM Series but offers up to 15 times the life of an equivalent ball screw.

I Series™ Features

- Proven Exlar roller screw technology
- Flexible mounting options
- Adapts to various types of motors
- Optional inline planetary gear reducer for high force output from lower motor torques

IX Series™ Features

- IP65 sealing
- Roller screw provides 15X life of ball screw
- Low backlash

IM Series™ Features

- IP54 sealing
- Roller screw provides 5X life of ball screw
- Standard backlash



The Exlar Advantage

Motor Flexibility

The I Series actuators can be ordered to accept the motor type of your choice. Whether a brushed type DC motor or stepper motor for lower performance applications, or a high performance brushless motor like Exlar's SLM Series, the I Series actuators offer complete flexibility in ordering to accept any type.

Integral Planetary Gearing

The I Series actuators offer economical planetary gearing as an input reduction option. Compared to the low performance spur gears provided by most ball screw actuators, the I Series' planetary gears offer an extended life, high input speed and output torque and quiet operation. The performance of the actuator is not limited by the gearing. Standard available ratios of 5:1 and 10:1 allow you to utilize smaller, lower torque motors to drive the I Series actuators, while still achieving the desired output force from the actuator.



Sealed Actuator Body

The base unit of the IX Series actuators is offered with a standard IP65 rating. The in-line motor mounting adapters and parallel motor mounting adapters can be ordered as IP65 if required for the application.

The base unit of the IM Series actuators is offered with a standard IP54 rating. An optional IP65 sealed base unit is available.

The in-line motor mounting adapters and parallel motor mounting adapters can be ordered with IP65 if required for the application.

Wear and Corrosion Resistant Output Rod

The standard actuator main extending rods for the I Series actuators are provided with a surface treatment that provides equivalent corrosion resistance and superior wear resistance to chrome plated rods. The thermo-chemical process creates a surface that is a microstructural zone of iron nitrides, integral with the base material. The resultant surface not only has superior wear qualities compared to chrome, and equivalent corrosion resistance, but also eliminates the flaking issues of an electro-chemically applied process such as chrome plating.

Large Diameter Output Rod

The I Series actuators provide a large diameter output rod and excellent internal bushing support which offers you long life in resistance to side loading.

Actuator Materials and Coating

The standard IM and IX Series actuators provide case materials made of aluminum with clear and black anodized coatings. These materials offer a durable and corrosion resistant package. The standard mounting hardware for the actuators are manufactured from black oxide-coated mild steel.

Alternative Materials and Coatings

The I Series actuators offer several options to the standard construction for applications requiring further corrosion resistance. The actuator's case parts can be ordered as electroless nickel coated and white powder coat epoxy.

The mounting hardware for the I Series actuators can be ordered in two varieties offering more corrosion resistance than the standard components. These include the "corrosion resistant" mounting accessories which are constructed of mild steel and provided with the same surface preparation as the output rod. Also offered are mounting accessories manufactured from stainless steel.



Ultimate Flexibility

I Series Life Curves See page 76 for explanation of life curve calculation.

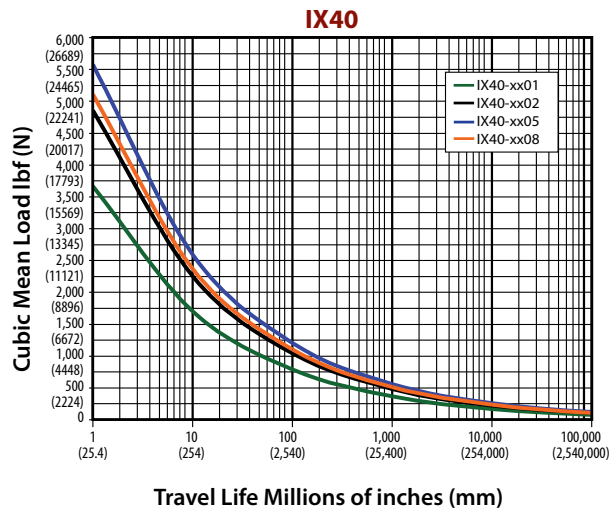
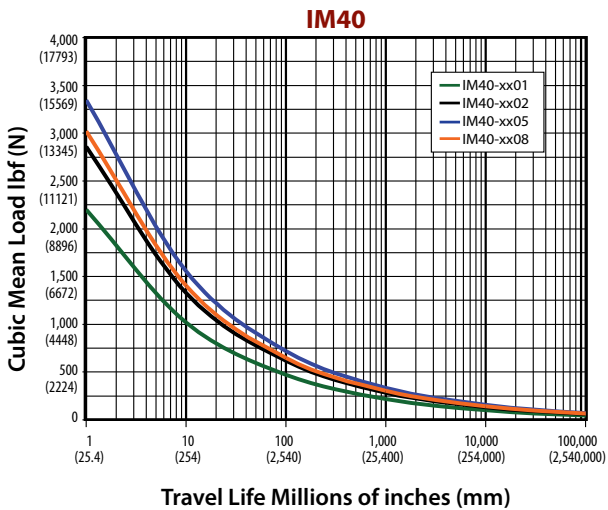
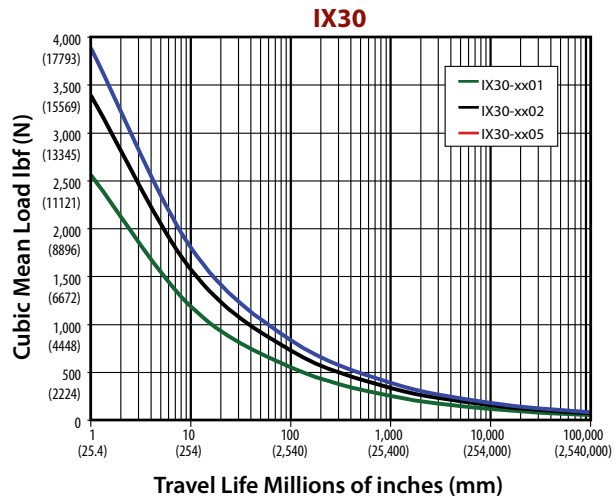
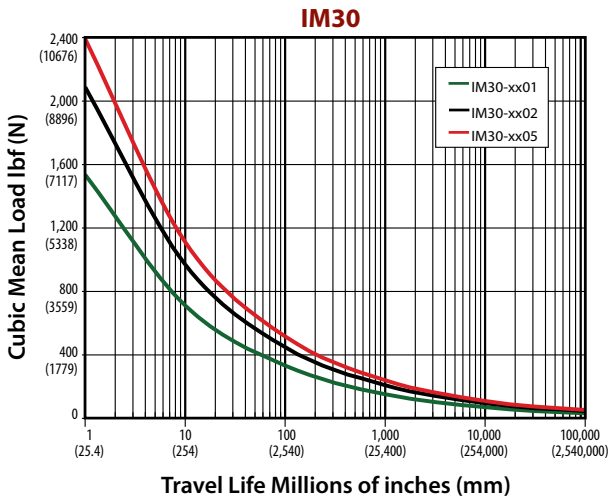
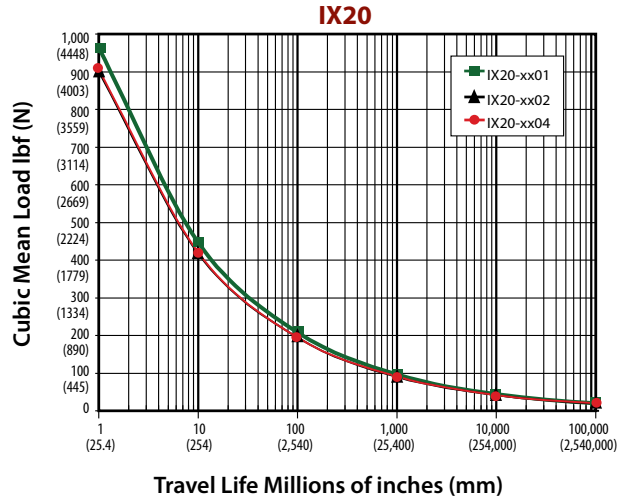
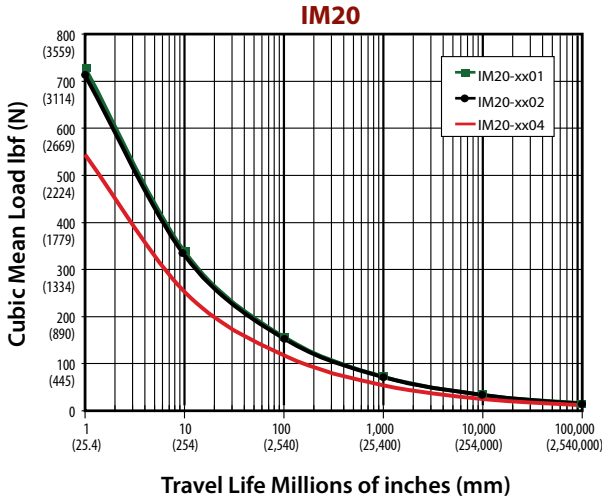

I Series Performance Specifications

Model No.	Approx Frame Size in (mm)	Continuous Force* lbf (N)	Peak Force lbf (N)	Speed at Max Rated RPM in/sec (mm/sec)	Life at Rated Continuous Force inx10 ⁶ (mmx10 ⁶)	Dynamic Load Rating lbf (N)	Screw Lead in (mm)	Allowable Continuous Input Torque lbf-in (Nm)	Allowable Peak Input Torque lbf-in (Nm)	Max Rated Input RPM
IM20-xx01	2 (51)	578 (2571)	1156 (5142)	8.33 (212)	2.9 (73.7)	1782 (7927)	0.1 (2.54)	11.5 (1.3)	23 (2.6)	5000
IM20-xx02		289 (1286)	578 (2571)	16.67 (423)	13.1 (332.7)	1165 (5182)	0.2 (5.08)	11.5 (1.3)	23 (2.6)	
IM20-xx04		145 (645)	289 (1286)	33.33 (847)	44.7 (1135.4)	696 (3096)	0.4 (10.16)	11.5 (1.3)	23 (2.6)	
IX20-xx01		578 (2571)	1156 (5142)	8.33 (212)	7.8 (198.2)	2470 (10987)	0.1 (2.54)	11.5 (1.3)	23 (2.6)	
IX20-xx02		385 (1713)	769 (3420)	16.67 (423)	41.3 (1049)	2273 (10111)	0.2 (5.08)	15.3 (1.73)	30.6 (3.5)	
IX20-xx04		192 (854)	385 (1713)	33.33 (847)	140.6 (3571.2)	1357 (6036)	0.4 (10.16)	15.3 (1.73)	30.6 (3.5)	
IM30-xx01		3 (76)	1347 (5992)	2694 (11984)	6.67 (169)	2.1 (53.3)	3697 (16445)	0.1 (2.54)	26.8 (3.03)	
IM30-xx02	674 (2998)		1347 (5992)	13.33 (338)	7.0 (177.6)	2204 (9804)	0.2 (5.08)	26.8 (3.03)	53.6 (6.1)	
IM30-xx05	269 (1197)		539 (2398)	33.33 (846)	346.0 (8788.4)	2383 (10600)	0.5 (12.7)	26.8 (3.03)	53.6 (6.1)	
IX30-xx01	1347 (5992)		2694 (11984)	6.67 (169)	5.5 (139.8)	5124 (22793)	0.1 (2.54)	26.8 (3.03)	53.6 (6.1)	
IX30-xx02	905 (4026)		1810 (8051)	13.33 (338)	21.5 (546.1)	4300 (19127)	0.2 (5.08)	36.0 (4.07)	72.0 (8.1)	
IX30-xx05	362 (1610)		724 (3221)	33.33 (846)	1059.8 (26918.2)	4649 (20680)	0.5 (12.7)	36.0 (4.07)	72.0 (8.1)	
IM40-xx01	4 (102)		3966 (17642)	7932 (35283)	5 (127)	0.4 (10.16)	6124 (27241)	0.1 (2.54)	78.9 (8.91)	157.8 (17.8)
IM40-xx02		1983 (8821)	3966 (17642)	10 (254)	2.1 (53.3)	4353 (19363)	0.2 (5.08)	78.9 (8.91)	157.8 (17.8)	
IM40-xx05		793 (3527)	1586 (7055)	25 (635)	32.6 (829)	3193 (14203)	0.5 (12.7)	78.9 (8.91)	157.8 (17.8)	
IM40-xx08		529 (2351)	1058 (4706)	37.5 (952)	174.3 (4427.2)	3251 (14461)	0.75 (19.05)	78.9 (8.91)	157.8 (17.8)	
IX40-xx01		3966 (17642)	7932 (35283)	5 (127)	1.0 (25.4)	8488 (37757)	0.1 (2.54)	78.9 (8.91)	157.8 (17.8)	
IX40-xx02		2692 (11975)	5383 (23945)	10 (254)	6.3 (160)	8492 (37774)	0.2 (5.08)	107.1 (12.1)	214.2 (24.2)	
IX40-xx05		1077 (4791)	2153 (9577)	25 (635)	96.9 (2461.2)	6230 (27712)	0.5 (12.7)	107.1 (12.1)	214.2 (24.2)	
IX40-xx08		718 (3193)	1436 (6388)	37.5 (952)	517.5 (13144.5)	6343 (28215)	0.75 (19.05)	107.1 (12.1)	214.2 (24.2)	

* The continuous force rating is achieved at the allowable continuous input torque level.

Specifications subject to change without notice.

For configurations that use an input ratio, the input torque rating must be divided by the ratio. The output force ratings remain the same.

For the 2:1 parallel belt ratio the input torque ratings must be divided by 2 for allowable motor torque.

For the 5:1 internal planetary gearing option the input torque ratings must be divided by 5 for allowable motor torque.

For the 10:1 internal planetary gearing option the input torque ratings must be divided by 10 for allowable motor torque.

For any custom belt ratio or externally mounted gearing, the input torque ratings must be divided by that ratio for the allowable motor torque.

I Series Mechanical Specifications

		IM20/IX20	IM30/IX30	IM40/IX40
Nominal Backlash	in (Nm)	.008 (.2) / .004 (.1)	.008 (.2) / .004 (.1)	.008 (.2) / .004 (.1)
Lead Accuracy	(mm/300 mm)	.001 (.025)	.001 (.025)	.001 (.025)
Maximum Radial Load	lb (N)	25 (111)	35 (155)	45 (200)
Friction Torque	lbf-in (Nm)	1.5 (0.17) / 3 (0.34)	2 (0.28) / 4 (0.45)	3 (0.34) / 6 (0.68)
Damping Constant	lbf-in/Krpm (Nm/Krpm)	0.5 (0.06)	1 (0.10)	3 (0.34)
Environmental Rating: Standard/optional for IM		IP54 / IP65	IP54 / IP65	IP54 / IP65
Maximum Operating Temperature		175°F / 80°C	175°F / 80°C	175°F / 80°C
WEIGHTS		lb (kg)		
Base Unit - Zero Stroke		2.32 (1.1)	5.29 (2.4)	14.6 (6.6)
Adder per inch of stroke		0.33 (.15)	0.63 (.3)	1.31 (.6)
Adder for inline (excluding motor)		0.73 (.33)	0.98 (.44)	0.2* (.09)
Adder for gearset		1.63 (.74)	3.32 (1.5)	9.91 (4.5)
Adder for front flange		0.44 (.2)	1.74 (.79)	2.6 (1.2)
Adder for parallel drive (excluding motor)		2.53 (1.15)	2.51(1.14)	11.7** (5.3)
Adder for 2 trunnions		2.12 (.96)	2.12 (.96)	2 (.91)
Adder for 2 side mounts		1.75 (.79)	1.75 (.79)	2.69 (1.2)
Adder for 2 adjustable flanges		1.46 (.66)	2.24 (1.02)	4.28 (1.94)

* For Nema motor size matching actuator size

** For Nema motor size matching actuator size (I40 adder for Nema 34 = 7.3)

Specifications subject to change without notice.

I Series Inertia

Actuator Configuration		lbf-in-sec ² (Kg-cm ²)
120 ACTUATOR	Base Unit - Input drive shaft only	0.0001+ 0.0000047/in (0.11 + 0.0053/in)
	Inline Unit - w/ motor collar clamp	0.00013+ 0.0000047/in (0.14 + 0.0053/in)
	5:1 Gearhead - w/ motor collar clamp	0.000062+ 0.00000019/in (0.07 + 0.00021/in)
	10:1 Gearhead - w/ motor collar clamp	0.000056+ 0.000000047/in (0.063 + 0.000053/in)
	1:1 Reduction parallel drive	0.00046+ 0.0000047/in (0.52 + 0.0053/in)
	2:1 Reduction parallel drive	0.00048+ 0.0000012/in (0.54 + 0.0013/in)
	1:2 Speed up ratio parallel drive	0.0015+ 0.000019/in (1.7 + 0.021/in)
130 ACTUATOR	Base Unit - Input drive shaft only	0.00043+ 0.000023/in (0.487 + 0.0256/in)
	Inline Unit - w/ motor collar clamp	0.00053+ 0.000023/in (0.596 + 0.0256/in)
	5:1 Gearhead - w/ motor collar clamp	0.00023+ 0.000001/in (0.254 + 0.001/in)
	10:1 Gearhead - w/ motor collar clamp	0.00020+ 0.0000003/in (0.23 + 0.00026/in)
	1:1 Reduction parallel drive	0.00075+ 0.000023/in (0.845 + 0.0256/in)
	2:1 Reduction parallel drive	0.00046+ 0.0000057/in (0.52 + 0.0256/in)
	1:2 Speed up ratio parallel drive	0.003+ 0.000091/in (3.4 + 0.1/in)
140 ACTUATOR	Base Unit - Input drive shaft only	0.00145+ 0.000073/in (1.65 + 0.0823/in)
	Inline Unit - w/ motor collar clamp	0.002+ 0.000073/in (2.15 + 0.0823/in)
	5:1 Gearhead - w/ motor collar clamp	0.0045+ 0.000003/in (5.11 + 0.00329/in)
	10:1 Gearhead - w/ motor collar clamp	0.0034+ 0.0000007/in (3.87 + 0.000823/in)
	1:1 Reduction parallel drive, 3 inch motor"	0.0023 + 0.000073/in (2.67 + 0.082/in)
	2:1 Reduction parallel drive, 3 inch motor"	0.00073 + 0.000018/in (0.83 + 0.02/in)
	1:2 Speed up ratio parallel drive, 3 inch motor"	0.011 + 0.00029/in (12.6 + 0.34/in)
	1:1 Reduction parallel drive, 4 inch motor"	0.021 + 0.000073/in (23.9 + 0.082/in)
	2:1 Reduction parallel drive, 4 inch motor"	0.0082 + 0.000018/in (9.27 + 0.020/in)
1:2 Speed up ratio parallel drive, 4 inch motor"	0.039 + 0.000029/in (44.4 + 0.33/in)	

NEMA Standard Motor Dimensions

The I Series actuators offer the selection for motor mounting provisions to be the various NEMA motor sizes. Because there are variations from brand to brand of motor as to what is called NEMA dimensions, we publish this table of NEMA dimensions that we use as the standards for the product line.

If the motor that you choose differs from these dimensions, it would not be called out by the N23, N34, N42, N56 call outs, and rather, by the A## alpha numeric callout for specific motors.

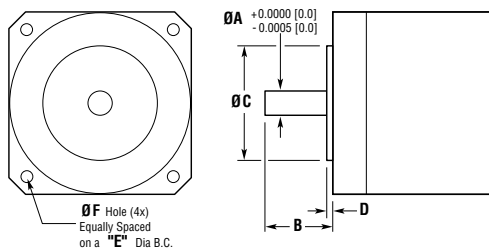

Dimension (in)	NEMA 23	NEMA 34	NEMA 42	NEMA 56
"A" Motor Shaft Diameter	0.25	0.5	0.75	0.625
"B" Motor Shaft Length	0.81	1.19	2.19	2.0625
"C" Motor Pilot Diameter	1.5	2.875	2.186	4.5
"D" Pilot Depth	0.05	0.0625	0.0625	0.1 - 0.16
"E" Mounting Bolt Circle	2.625	3.875	4.95	5.875
"F" Mounting Bolt Hole Dia.	0.205	0.223	0.328	3/8-16 UNC tap

Specifications subject to change without notice.

I20 Base Unit

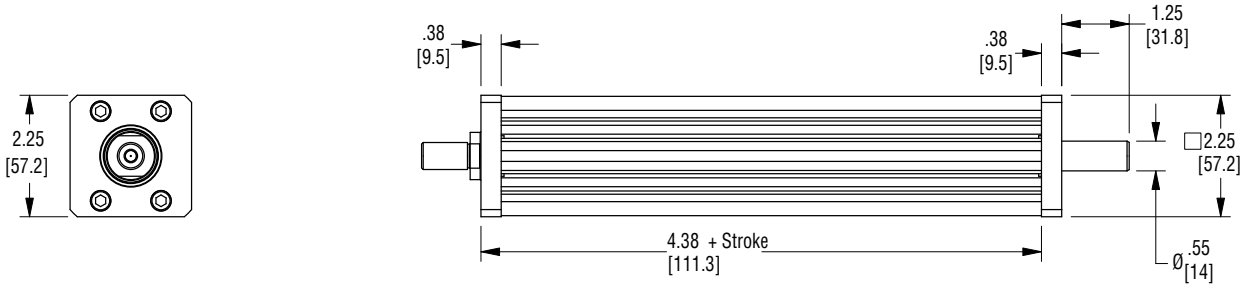

I20 Side Flange Attachments (*Integral Flange)

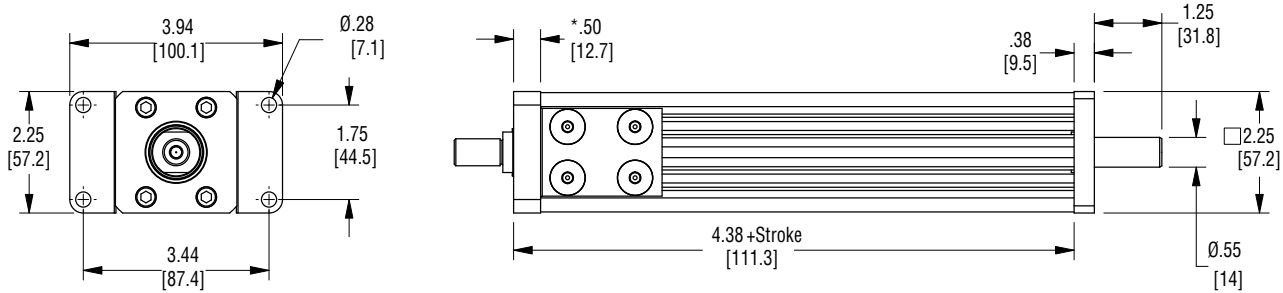

*Note: If using integral flange this dimension is .38 [9.5]

I20 Side Lug Attachments

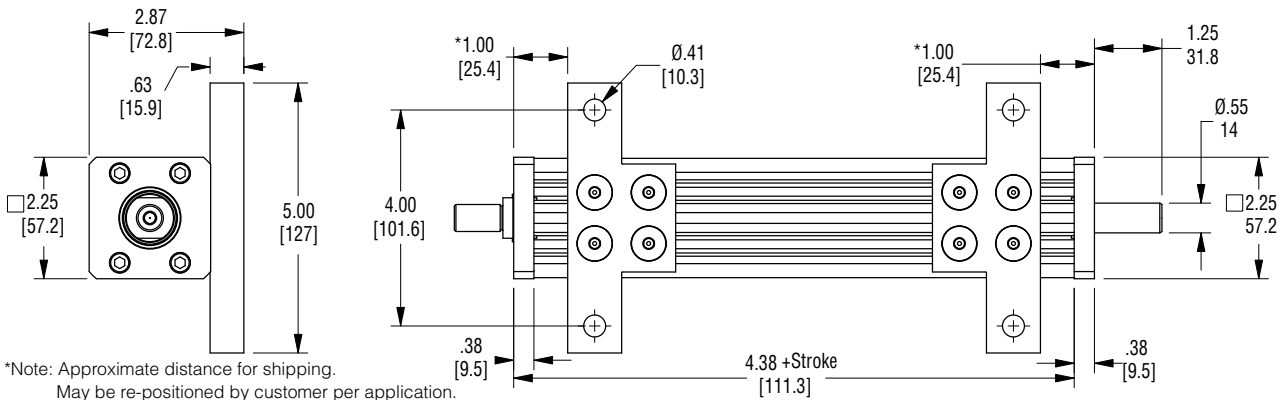

*Note: Approximate distance for shipping. May be re-positioned by customer per application.

I20 Side Trunnion Attachments

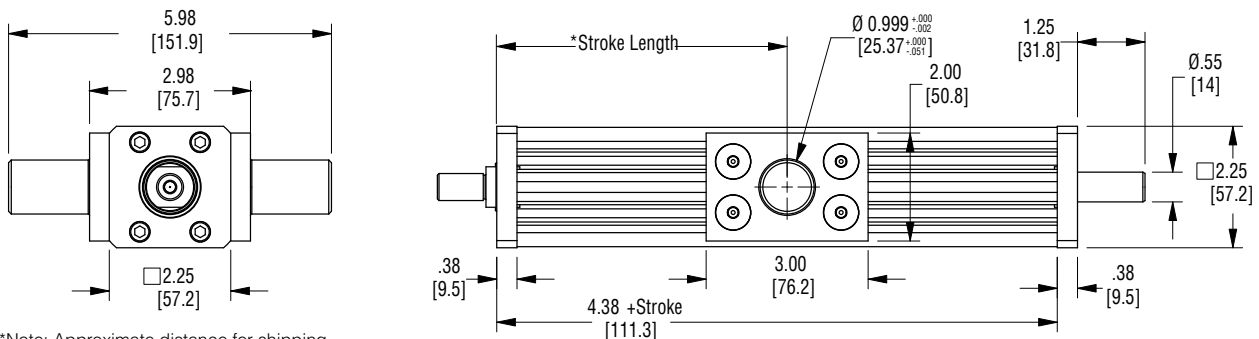

*Note: Approximate distance for shipping. May be re-positioned by customer per application.

I20 Parallel Drive

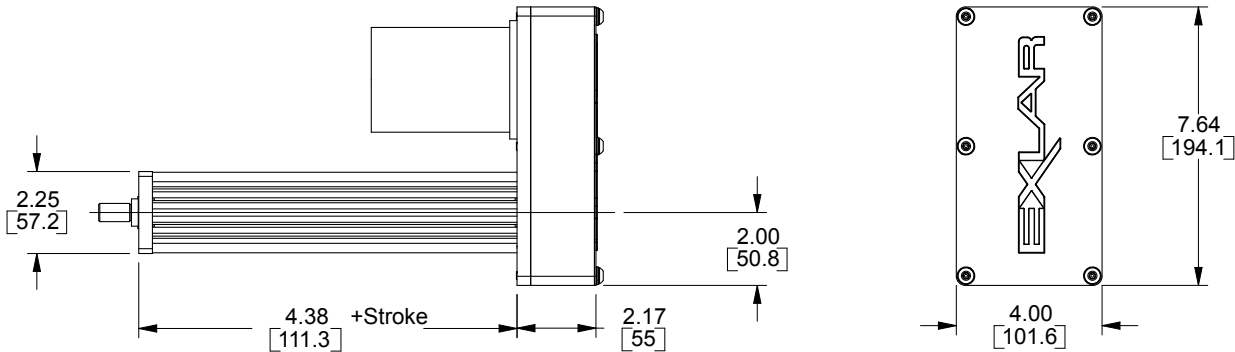

I20 Inline Integrated Coupling

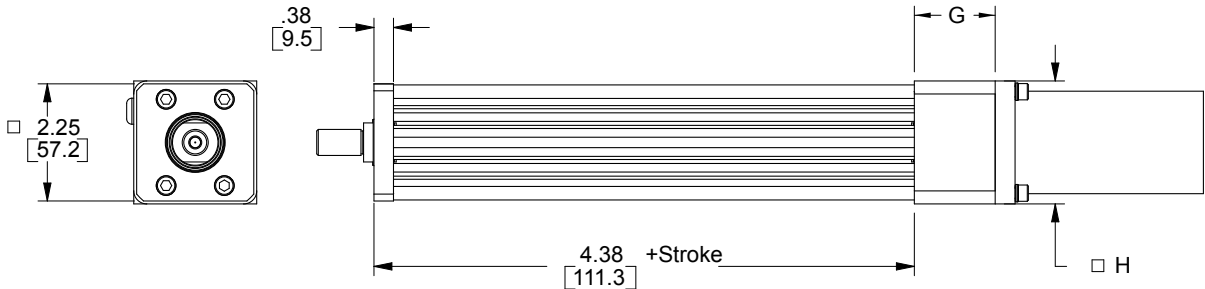

I20 5:1, 10:1 Planetary Gearset

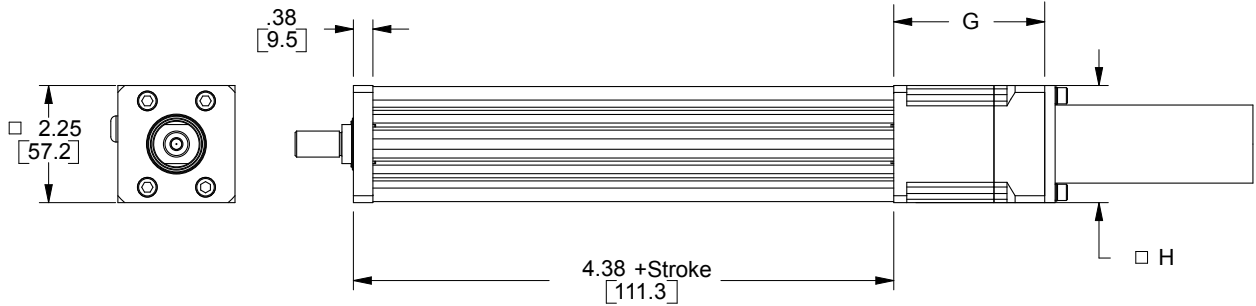

Motor Frame Size (Inline Integrated Coupling)	G in (mm)	H in (mm)
NEMA 23	1.25 (31.8)	2.25 (51.2)
Exlar 60 mm	1.55 (39.4)	2.36 (60.0)
NEMA 34	1.37 (34.7)	3.25 (82.6)
NEMA 42	1.37 (34.7)	4.19 (106.4)
Motor Frame Size (5:1, 10:1 Planetary Gearset)		
NEMA 23	2.90 (73.7)	2.25 (57.2)
Exlar 60 mm	2.90 (73.7)	2.36 (60.0)
NEMA 34	8.57 (217.7)	11.04 (280.5)

I Series

I Series Linear Actuators

I30 Base Unit

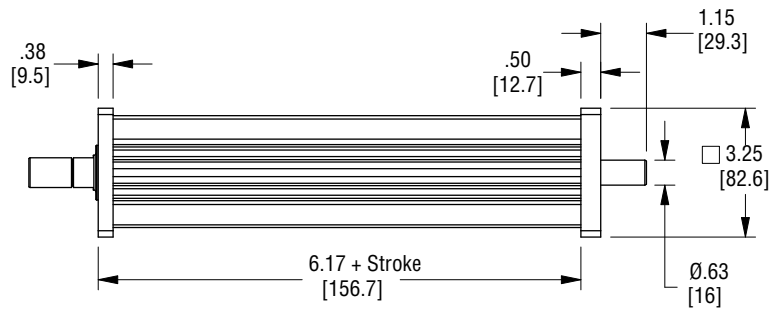
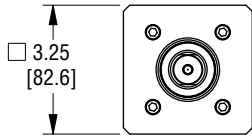

I30 Side Flange Attachments (*Integral Flange)

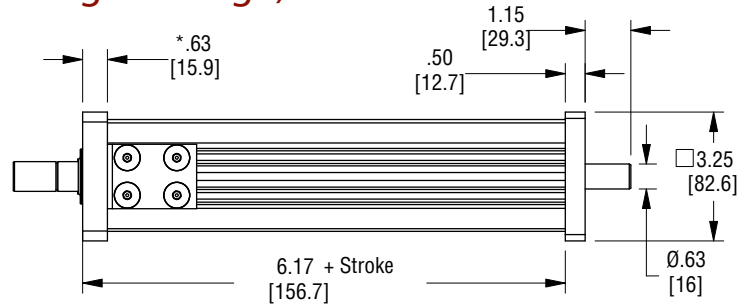
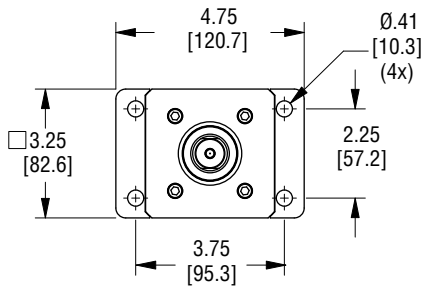

* Note: If using integral flange this dimension is .50 [12.7]

I30 Side Lug Attachments

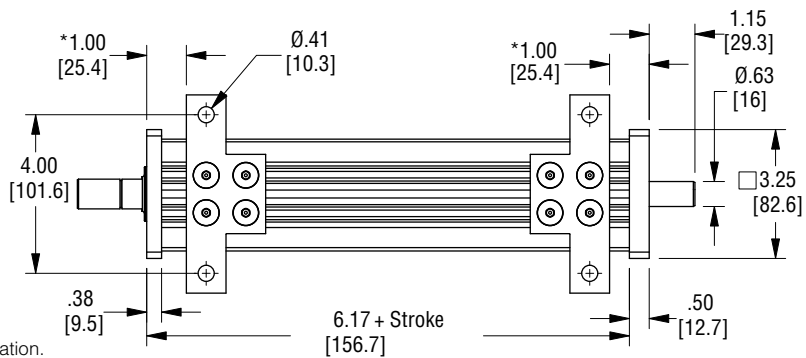
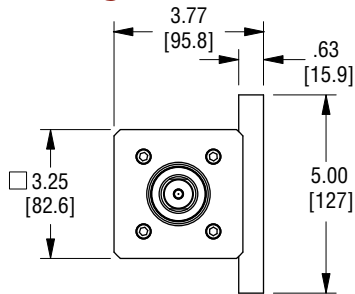

* Note: Approximate distance for shipping. May be re-positioned by customer per application.

I30 Side Trunnion Attachments

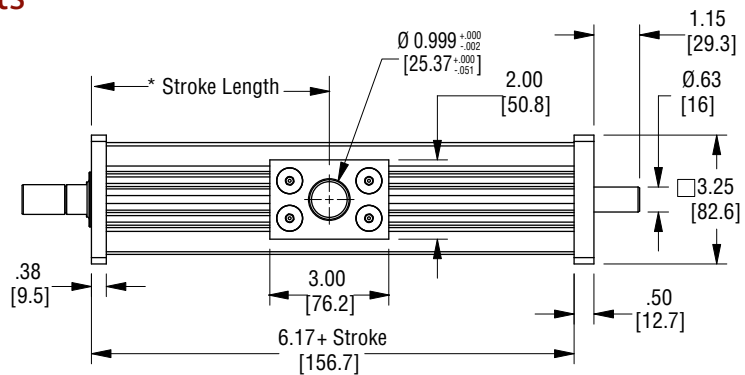
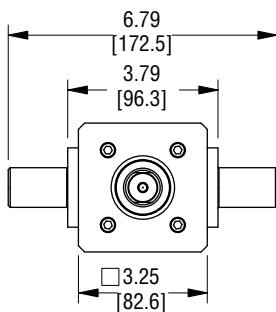

* Note: Approximate distance for shipping. May be re-positioned by customer per application.

I30 Parallel Drive

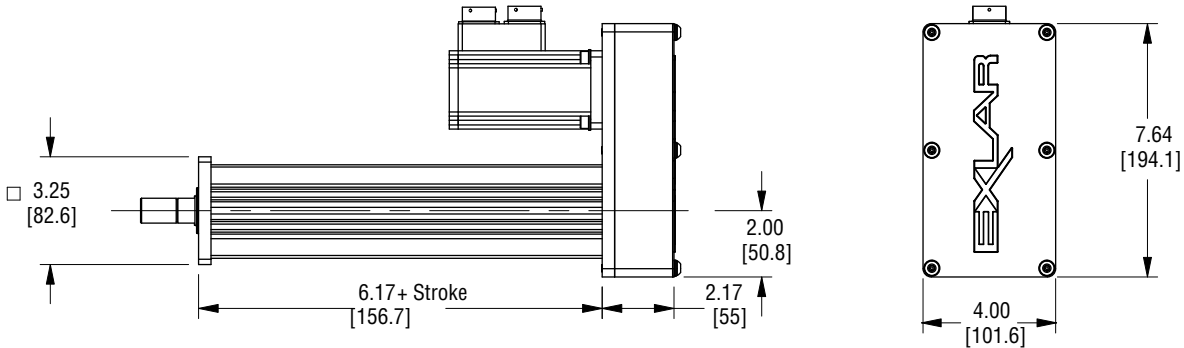

I30 Inline Integrated Coupling

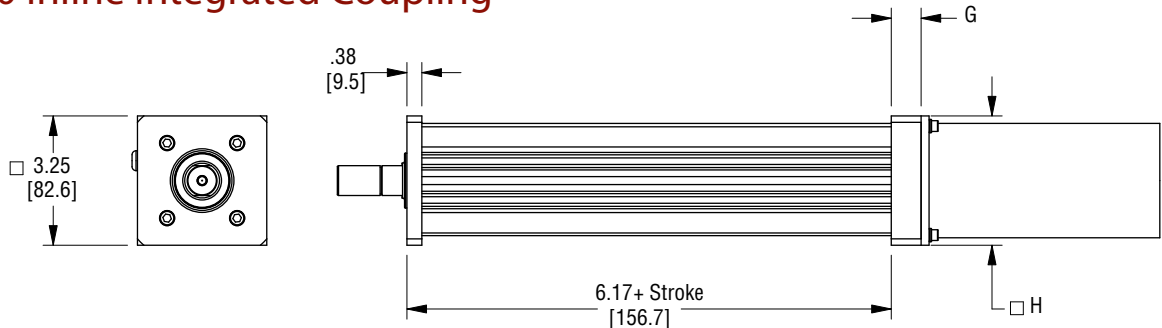

I30 5:1, 10:1 Planetary Gearset

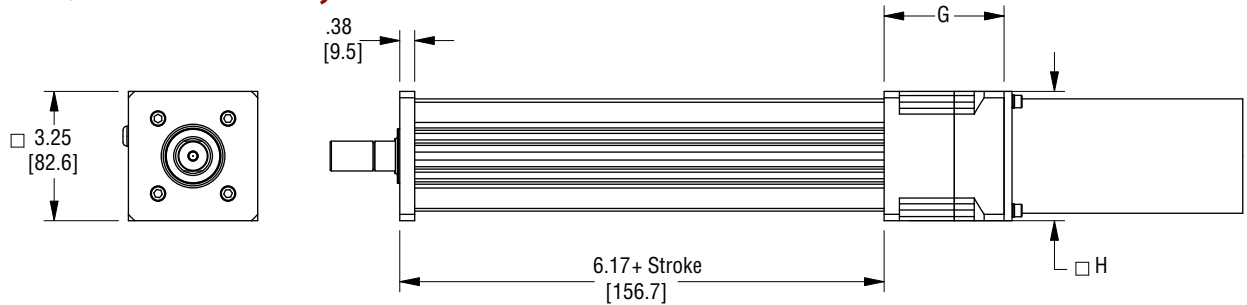

Motor Frame Size (Inline Integrated Coupling)	G in (mm)	H in (mm)
NEMA 23	0.80 (20.3)	3.25 (82.6)
Exlar 60 mm	0.80 (20.3)	3.25 (82.6)
NEMA 34	0.68 (17.1)	3.25 (82.6)
Exlar 90 mm	1.44 (36.6)	3.31 (84.0)
NEMA 42	0.68 (17.1)	4.19 (106.4)
Motor Frame Size (5:1, 10:1 Planetary Gearset)		
NEMA 23	2.95 (74.8)	3.25 (82.6)
Exlar 60 mm	2.95 (74.8)	3.25 (82.6)
NEMA 34	2.95 (74.8)	3.25 (82.6)
Exlar 90 mm	3.29 (83.4)	3.52 (89.4)
NEMA 42	2.95 (74.8)	4.19 (106.4)

I Series Linear Actuators

I40 Base Unit

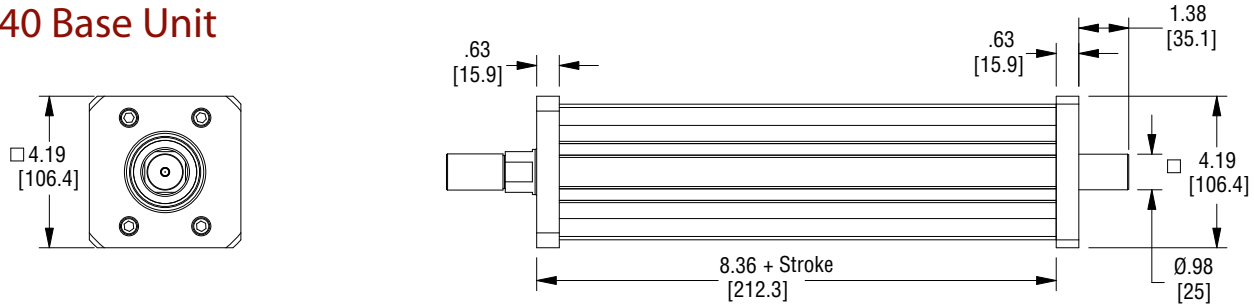

I40 Side Flange Attachments (*Integral Flange)

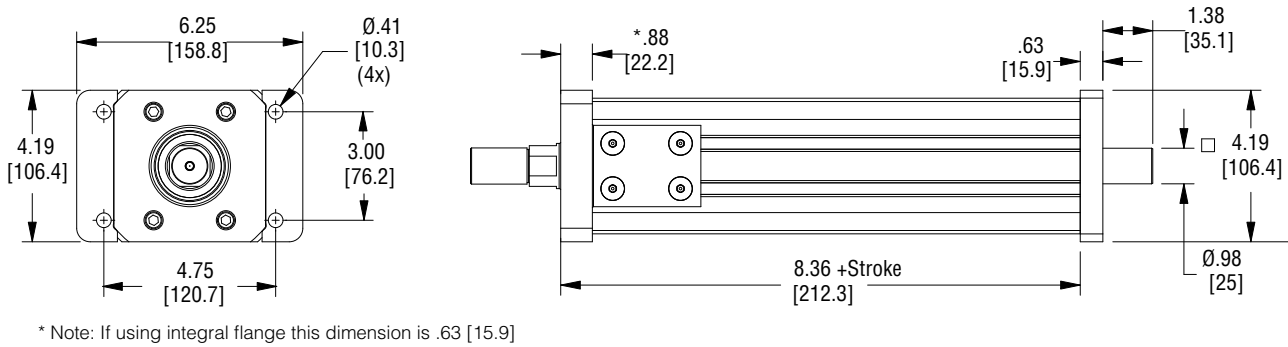

I40 Side Lug Attachments

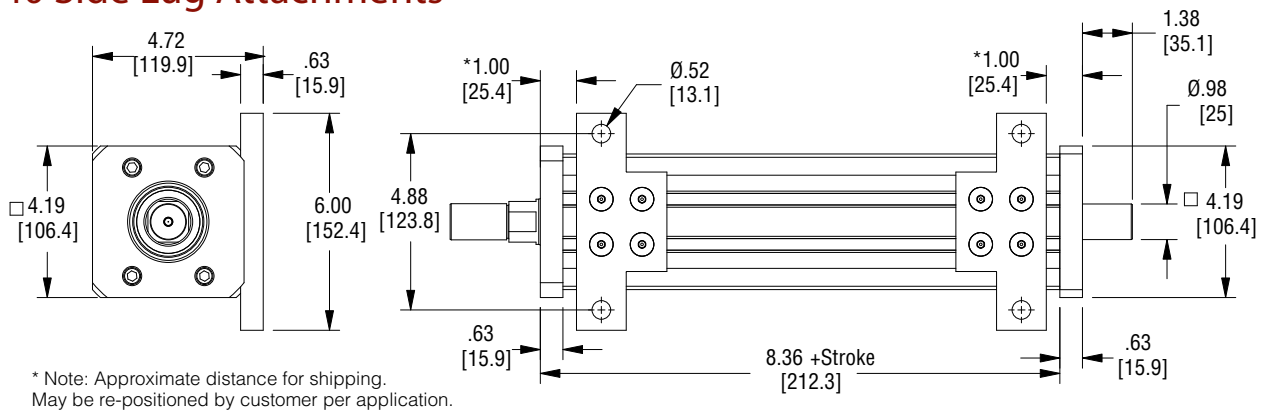

I40 Side Trunnion Attachments

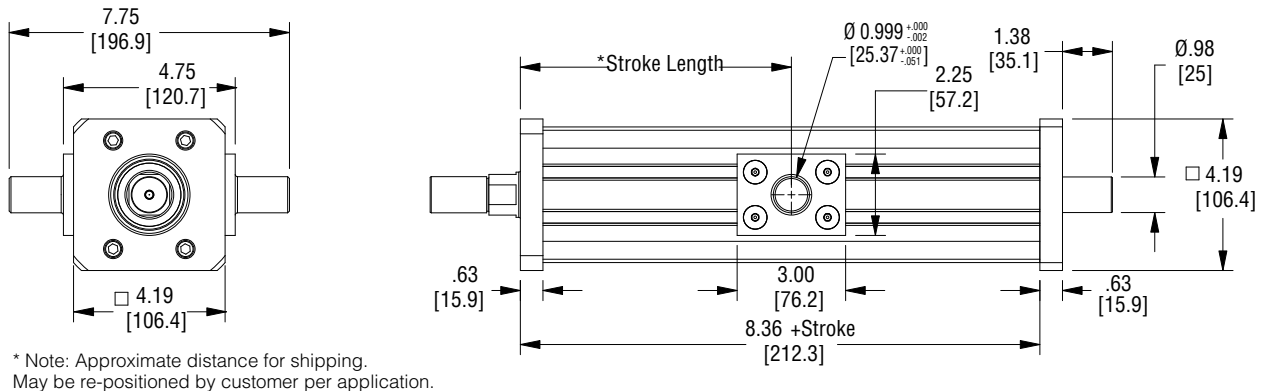

I40 Parallel Drive

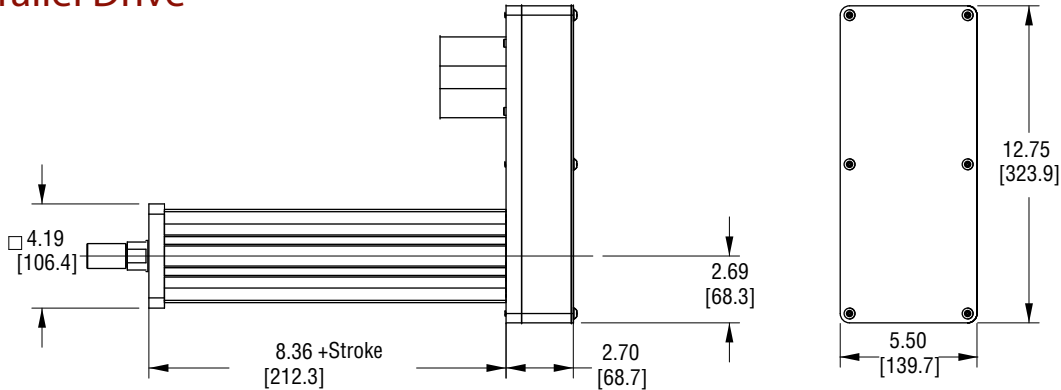

I40 Inline Integrated Coupling

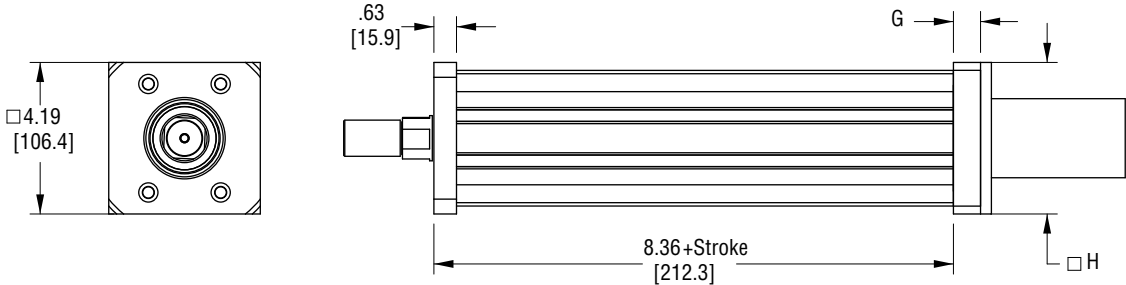

I40 5:1, 10:1 Planetary Gearset

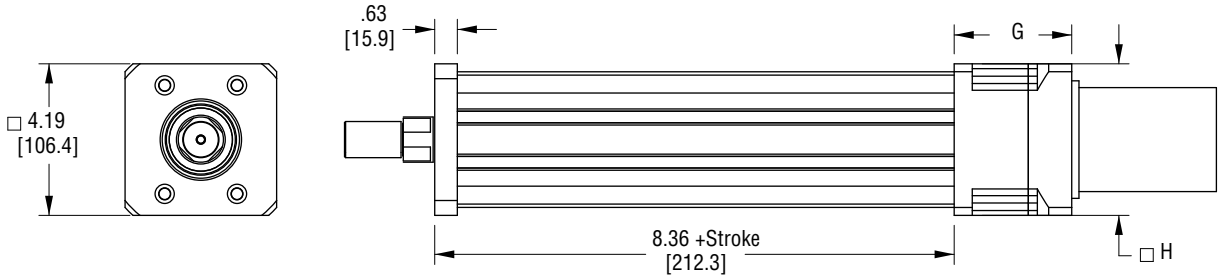

Motor Frame Size (Inline Integrated Coupling)	G in (mm)	H in (mm)
NEMA 34	0.75 (19.1)	4.19 (106.4)
Exlar 90 mm	1.00 (25.4)	
NEMA 42	0.75 (19.1)	
Exlar 115 mm	1.25 (31.75)	
Motor Frame Size (5:1, 10:1 Planetary Gearset)		
NEMA 34	3.25 (82.6)	4.19 (106.4)
Exlar 90 mm	3.45 (87.6)	
NEMA 42	3.25 (82.6)	
Exlar 115 mm	3.88 (98.6)	

I Series

I20 Rod Ends

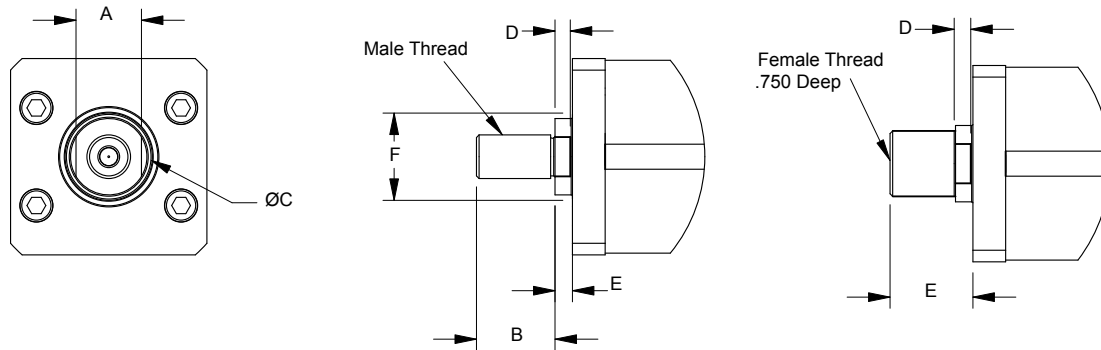

Rod End Option	Thread	A in (mm)	B in (mm)	C in (mm)	D in (mm)	E in (mm)	F in (mm)
M	U.S. Male 1/2-20 UNF-2A	0.7 (19.1)	0.90 (22.9)	0.88 (22.2)	0.18 (4.4)	0.20 (5.1)	1.00 (25.4)
F	U.S. Female 1/2-20 UNF-2B		na			0.95 (24.1)	
A	Metric Male M12 x 1.5		0.90 (22.9)			0.20 (5.1)	
B	Metric Female M12 x 1.5		na			0.95 (24.1)	

I30 Rod Ends

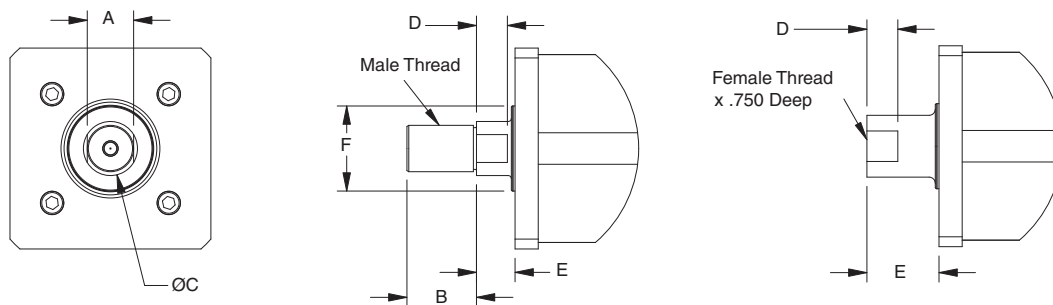

Rod End Option	Thread	A in (mm)	B in (mm)	C in (mm)	D in (mm)	E in (mm)	F in (mm)
M	U.S. Male 3/4-16 UNF	0.75 (19.1)	1.13 (28.6)	0.88 (22.3)	0.50 (12.7)	0.62 (15.8)	1.38 (35.0)
F	U.S. Female 3/4-16 UNF	0.87 (22.1)	na	1.00 (25.4)		1.17 (29.7)	
A	Metric Male M16 x 1.5	0.75 (19.1)	1.13 (28.6)	0.88 (22.3)		0.62 (15.8)	
B	Metric Female M16 x 1.5	0.87 (22.1)	na	1.00 (25.4)		1.17 (29.7)	

I40 Rod Ends

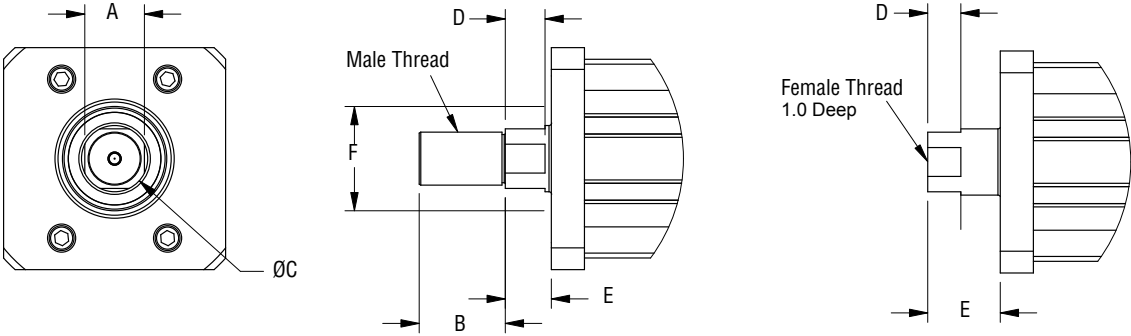

Rod End Option	Thread	A in (mm)	B in (mm)	C in (mm)	D in (mm)	E in (mm)	F in (mm)
M	U.S. Male 1-14 UNS-2A	1.13 (28.6)	1.63 (41.3)	1.25 (31.8)	0.75 (19.1)	0.87 (22.1)	1.97 (50.0)
F	U.S. Female 1-14 UNS-2B		na		0.63 (15.9)	1.37 (34.8)	
A	Metric Male M27 x 2		1.63 (41.3)		0.75 (19.1)	0.87 (22.1)	
B	Metric Female M24 x 2		na		0.63 (15.9)	1.37 (34.8)	

Rod Clevis Dimensions

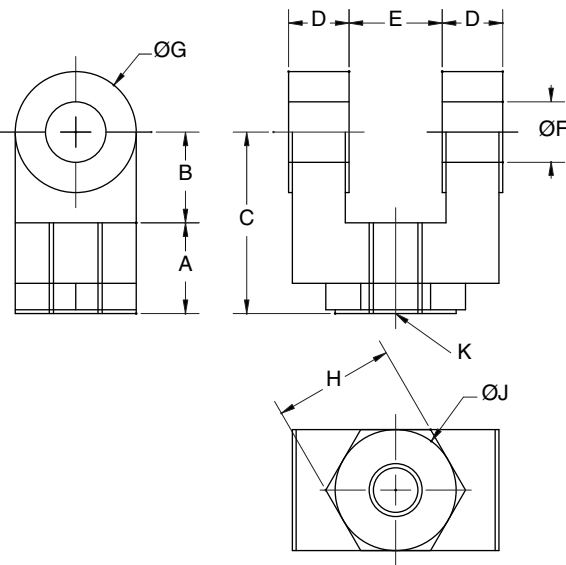

in (mm)	I20* RC1050	I30 RC075	I40 RC100
A	0.750 (19.05)	1.125 (28.58)	1.625 (41.2)
B	0.750 (19.05)	1.25 (31.75)	1.500 (38.1)
C	1.500 (38.1)	2.375 (60.3)	3.125 (79.4)
D	0.500 (12.7)	0.625 (15.88)	.750 (19.1)
E	0.765 (19.43)	1.265 (32.13)	1.515 (38.5)
ØF	0.500 (12.7)	0.75 (19.1)	1.000 (25.4)
ØG	1.000 (25.4)	1.50 (38.1)	2.000 (50.8)
H	1.000 (25.4)	1.25 (31.75)	1.500 (38.1)
ØJ	NA	1.25 (31.75)	1.500 (38.1)
K	1/2-20	3/4-16	1-14

*Requires 0.5 in. dia. pin CPO50.

Spherical Rod Eye Dimensions

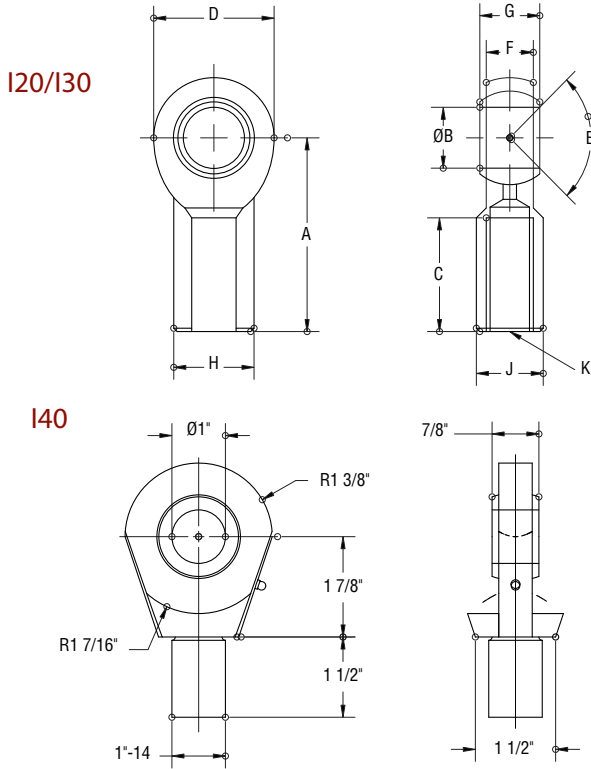

in (mm)	I20 SRM050	I30 SRM075	I40 SRF100
A	2.125 (54.0)	2.88 (73.2)	See Spherical Rod Eye Drawing. Requires Female Rod End.
ØB	0.472 (12)	0.75 (19.1)	
C	1.156 (29.4)	1.72 (43.7)	
D	1.312 (33.3)	1.75 (44.5)	
E	6 Deg	14 Deg	
F	.500 (12.7)	0.69 (17.5)	
G	.625 (15.9)	0.88 (22.3)	
H	.875 (22.2)	1.13 (28.7)	
J	.750 (19.1)	1.00 (25.4)	
K	1/2-20	3/4-16	

Clevis Pin Dimensions

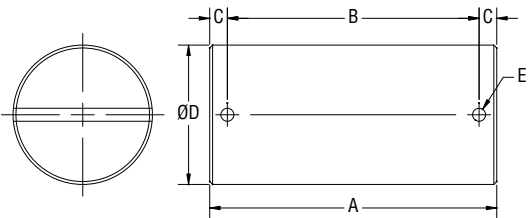

	A in (mm)	B in (mm)	C in (mm)	ØD in (mm)	ØE in (mm)
I20 CP050	2.28 (57.9)	1.94 (49.28)	0.17 (4.32)	0.50" +0.000/-0.002 (12.7 mm +0.00/-0.05)	0.106 (2.69)
I30 CP075	3.09 (78.5)	2.72 (69.1)	0.19 (4.82)	0.75" +0.000/-0.002 (19.1 mm +0.00/-0.05)	0.14 (3.56)
I40 CP100	3.59 (91.2)	3.22 (81.8)	0.19 (4.82)	1.00" +0.000/-0.002 (25.4 mm +0.00/-0.05)	0.14 (3.56)

Rod Eye Dimensions

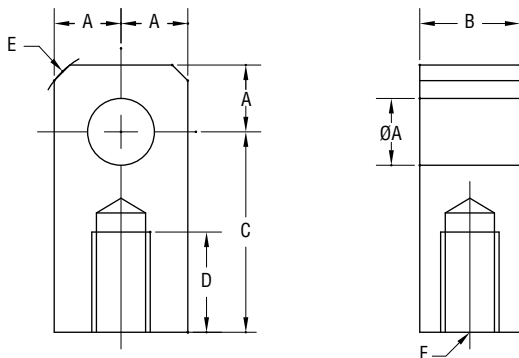

in (mm)	I20 REI050	I30 RE075	I40 RE100
ØA	0.50 (12.7)	0.75 (19.05)	1.00 (25.4)
B	0.75 (19.05)	1.25 (31.8)	1.50 (38.1)
C	1.50 (38.1)	2.06 (52.3)	2.81 (71.4)
D	0.75 (19.05)	1.13 (28.7)	1.63 (41.4)
E	0.375 (9.53)	0.88 (22.2)	1.19 (30.2)
F	1/2-20	3/4-16	1-14

I20 Case Dimensions

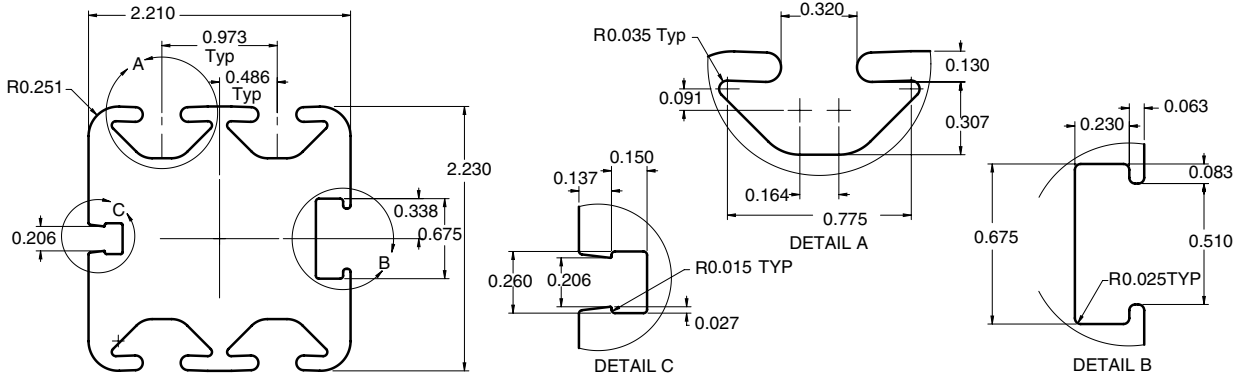

I30 Case Dimensions

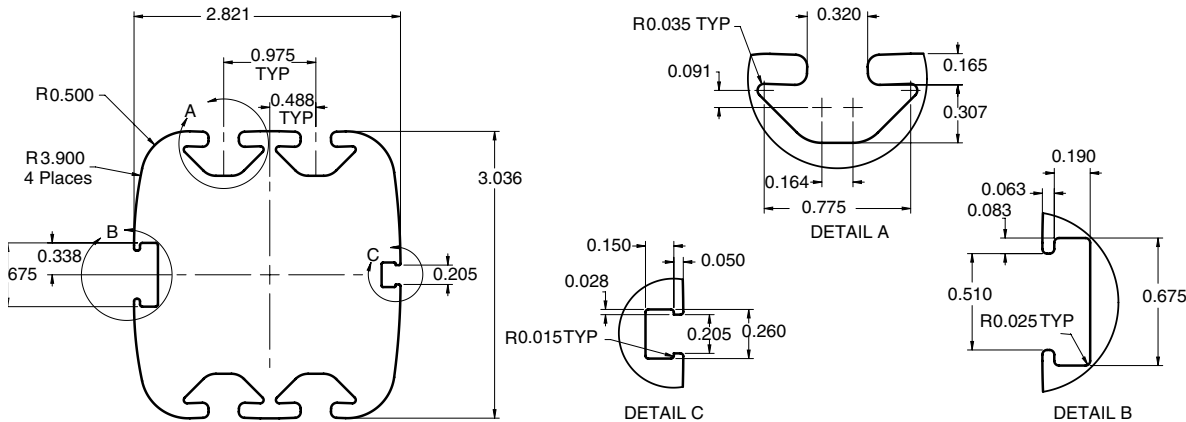

I40 Case Dimensions

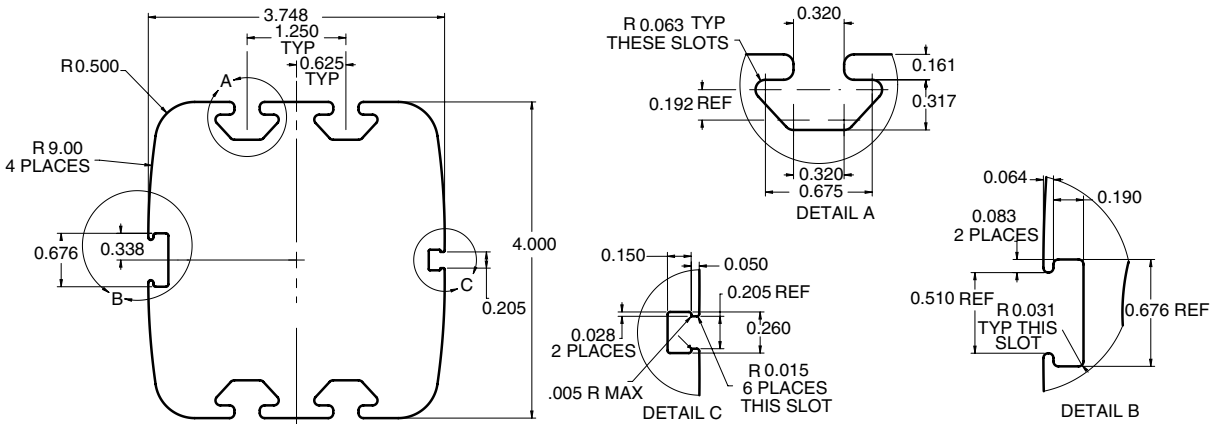

I Series

I Series Accessories Ordering Guide

I Series Mounting Attachments (includes proper number of standard T nuts and screws)	
Side Flange Attachments (Black Oxide Steel)	
ISFA-20	Size 20 I Series (2)
ISFA-30	Size 30 I Series (2)
ISFA-40	Size 40 I Series (2)
Side Trunnion Attachments	
ISTA-20	Size 20 I Series (2)
ISTA-30	Size 30 I Series (2)
ISTA-40	Size 40 I Series (2)
Side Lug Attachments	
ISLA-20	Size 20 I Series (2)
ISLA-30	Size 30 I Series (2)
ISLA-40	Size 40 I Series (2)

Mounting Attachments, Corrosion Resistant or Stainless Steel	
Stainless Steel Side Flange Attachments (Stainless Steel)	
ISSF-20	Size 20 I Series
ISSF-30	Size 30 I Series
ISSF-40	Size 40 I Series
Corrosion Resistant Side Trunnion Attachments (Treated Hardened Steel Trunnions)	
ICRT-20	Size 20 I Series
ICRT-30	Size 30 I Series
ICRT-40	Size 40 I Series
Stainless Steel Side Trunnion Attachments (Hardened Stainless Steel Trunnions)	
ISST-20	Size 20 I Series
ISST-30	Size 30 I Series
ISST-40	Size 40 I Series
Stainless Steel Side Lug Attachments (Stainless Steel)	
ISSL-20	Size 20 I Series
ISSL-30	Size 30 I Series
ISSL-40	Size 40 I Series
Standard T Nuts and Screws	
ITNUT	5/16 - 18 T nut - use with all mounts
ISCR34	5/16 - 18 x 3/4" screw - use with trunnion mounts
ISCR10	5/16 - 18 x 1" screw - use with side flange and side lug mount

Rod End Attachments, Standard Materials (Consult Factory for Corrosion Resistant Options)	
Spherical Rod Eye	
SRM-050	Size 20 I Series
SRM-075	Size 30 I Series
SRF-100	Size 40 I Series (fits standard imperial female threaded rod)
Rod Eye	
REI-050	Size 20 I Series
RE-075	Size 30 I Series
RE-100	Size 40 I Series
Rod Clevis	
RCI-050	Size 20 I Series (requires 0.5" dia. Pin, CP-050)
RC-075	Size 30 I Series
RC-100	Size 40 I Series
Clevis Pins for Rod Clevis/Rod Eye	
CP-050	Size 20 I Series
CP-075	Size 30 I Series
CP-100	Size 40 I Series
Clevis Pins for Spherical Rod Eye	
CP-050	Size 20 I Series
CP-075	Size 30 I Series
CP-100	Size 40 I Series

Replacement Limit Switches

Switch Type	Exlar Part Number	Turck Part Number
Normally Closed Switch	43404	BIM-UNT-RP6X
Normally Open Switch	43403	BIM-UNT-AP6X

Consult Exlar's application engineering department regarding all special actuator components.

Actuator Series

IM = Standard mechanical grade, IP54
IX = Premium mechanical grade, IP65

AA = Frame Size (nominal)

20 = 2 inch (60 mm)
30 = 3 inch (80 mm)
40 = 4 inch (100 mm)

BB = Stroke Length

02-18 = 2 to 18 inch (50-455 mm) 12 in. max on I20 in 2 inch (300 mm) increments. Special available strokes: Maximum 24 inch (609 mm) stroke is available for the I30 and maximum 24 in. (609 mm) stroke for the I40.

CC = Lead (linear motion per screw revolution)

01 = 0.1 inch (2.54 mm)
02 = 0.2 inch (5.08 mm)
04 = 0.4 inch (10.16 mm) I20 only
05 = 0.5 inch (12.7 mm) I30 and I40 only
08 = 0.75 inch (19.05 mm) I40 only, up to 8 inch stroke max.¹

D = Mounting Options

N = None, base unit
F = Front flange
X = Special

E = Rod End

M = Male, US std. thread
A = Male, metric thread
F = Female, US std. thread
B = Female, metric thread
X = Special (please specify)

FFF = Input Drive Provisions

NMT = Drive shaft only, no motor mount
G05 = Inline planetary gearing, 5:1 ratio
G10 = Inline planetary gearing, 10:1 ratio
ISC = Inline, includes shaft coupling
P10 = Parallel, 1:1 ratio
P20 = Parallel, 2:1 ratio
P## = Custom ratio, (ex. P13 = 1.3:1 ratio)

GGG = Motor Mount Provisions⁶

A## = Alpha numeric motor call out - contact Exlar Applications Engineering Department. Motor not included.
NMT = No motor mount - keyed shaft on base unit only
N23 = Nema 23 standard dimension
N34 = Nema 34 standard dimension
N42 = Nema 42 standard dimension. Not available on I20.
N56 = Nema 56 standard demension. Not available on I20 or I30.
M60 = Exlar 60 mm SLM. Motor not included. Not available on I40.
M90 = Exlar 90 mm SLM. Motor not included.
M11 = Exlar 115 mm SLM and ER. Motor not included. Available on I40 only.
M14 = Exlar 142 mm SLM. Motor not included. Available on I40 only.
G60 = Exlar 60 mm SLG. Motor not included. Not available on I40.
G90 = Exlar 90 mm SLG. Motor not included.
G11 = Exlar 11 mm SLG and ER. Motor not included. Available on I40 only.
AB3,4 = Allen Bradley 3 & 4 inch motors
BD3,4 = Baldor 3 & 4 inch motors
CM3,4 = Parker (Custom Servo Motors) Metric 3 & 4 inch motors
EE3,4 = Emerson EMC Imperial 3 & 4 inch motors
EM3,4 = Emerson CT Metric 3 & 4 inch motors
FA4 = Fanuc 4 inch motors
IN3,4 = Bosch-Rexroth (Indramat) 3 & 4 inch motors
KM2,4 = Kollmorgen 2, 3 & 4 inch motors
MT3,4 = Mitsubishi 3 & 4 inch motors
PS3,4 = Pacific Scientific PMA/PMB Series 3 & 4 inch motors
PC2,3 = Parker Compumotor 2.7, 3.6, 4.5, & 5.6 inch motors
SM2 = Siemens 2 inch motor
SM3 = Siemens 3 inch motor
YS3,4 = Yaskawa 3 & 4 inch motors
MXX = Unlisted or special motor mounting provisions to be assigned an alpha numeric code at time of order

X..XX = Travel and Housing Options (Multiple Possible)

EN = Electroless nickel plating of housing parts⁵
HC = Hard coat anodized, acceptable for food grade⁵
PB = Protective bellows for extending rod
L1 = One external limit switch, channel mount magnetic sensing proximity switch, N.O.³
L2 = Two external limit switches, channel mount magnetic sensing proximity switch, N.C. 10-30 VDC³
L3 = Three external limit switches, channel mount magnetic sensing proximity switch, 1 N.O., 2 N.C. 10-30 VDC³
L# = External limit switches, channel mount magnetic sensing prox switch³.
P5 = IP65 sealed housing (option for IM Series)
PF = Pre-loaded follower²
XH = Special housing option
XL = Special lubrication
XT = Special travel option

= Part No. Designator for Specials

Optional 5 digit assigned part number to designate unique model numbers for specials.

Consult Exlar's application engineering department regarding all special actuator components.

Note:

1. Maximum stroke length for 0.75 inch lead (19.05 mm) on I40 is 8" (228.6 mm).
2. The dynamic load rating of zero backlash, preloaded screws is 63% of the dynamic load rating of the standard non-preloaded screws. The calculated travel life of a preloaded screw will be 25% of the calculated travel life of the same size and lead of a non-preloaded screw.
3. Please see page 72 for limit switch details and replacements.
4. 90 mm square max frame size for I20. 100 mm square max frame size for I30. 120 mm square max frame size for I40. Consult Application Engineer for larger motors.
5. These housing options would typically be accompanied by the choice of the electroless nickel connectors if a connectorized unit were selected. This choice may also indicate the need for special material main rods or mounting.
6. NEMA callout must meet specifications on page 67 or use alpha numeric callout.