

Hazardous Location EL Series Linear Actuators

EL Series Explosion Proof Linear Actuators

This electromechanical system provides process engineers a clean, fast, simple and cost effective replacement for Hydraulic actuation and a longer life alternative to pneumatic actuation. The roller screw technology manufactured by Exlar outperforms rival ball screws by 15 times in travel life, and can carry higher loads. The compact design allows users to effectively replace hydraulic or air cylinders with an electromechanical actuator, yet meet all required capabilities of the application. Reduced emissions, reduced energy consumption (80% system energy efficiency), increased position control and accuracy – all leading to reduced cost – are provided by servo electric actuation.

The EL30 explosion-proof linear actuator offers CSA Class I*, Division 1, Groups B, C or D rating.

The EL100 explosion-proof linear actuator offers a Class I, Division 2, Groups B, C, D & T3. The EL100 linear actuators. Also meet ATEX essential requirements and are in Conformance with the EU ATEX Directive 94/9/EC.

The EL Series linear actuators are compatible with nearly any Manufacturers' resolver-based amplifier.

**"Class I" means that flammable gases or vapors may be present in the air in quantities sufficient to produce explosive or ignitable mixtures. "Division 1" means that hazardous concentrations in the air may exist continuously, intermittently, or periodically under normal operating conditions. "Group B" allows for atmospheres containing hydrogen, or gases (or vapors) of equivalent hazard, such as manufactured gas. "Group C" allows for atmospheres containing ethyl-ether vapors, ethylene or cyclo propane. "Group D" allows for atmospheres containing gasoline, hexane, naphtha, benzene, butane, alcohol, acetone, benzol, lacquer solvent vapors or natural gas. EL Series actuators are not rated for operation in atmospheres containing acetylene
Temperature classification defines the maximum surface temperature the product will reach at full load. T3 = 200 °C, T3A – 180 °C, T4 = 135 °C*

EL Series explosion-proof motors are well-suited to many applications:

Turbine fuel flow	Chemical process plants
Printing presses	Fuel distribution systems
Engine test stands	Shipbound fuel management
Valve control	Damper control
Paint booths	



**EL30
Explosion-Proof
Linear Actuator**

Class I, div 1, Groups B, C and D

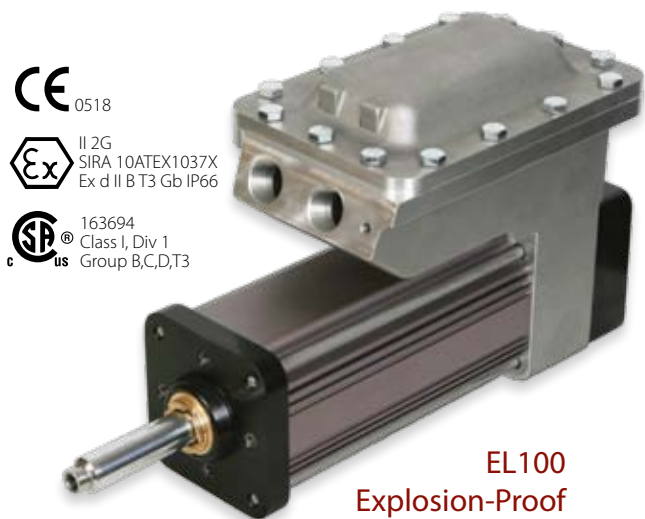

**EL100
Explosion-Proof
Linear Actuator**

Class I, div 1, Groups B, C, D and T3



Features

- T-LAM technology yielding 35% increase in continuous motor torque over traditional windings
- Forces to 2000 lbs
- Speeds to 25 ips
- Resolver feedback
- Strokes up to 6 inches
- 8 pole motors
- Rod end options
- Several mounting configurations
- Potted NPT connectors
- Windings available from 24 VDC to 460 VAC rms
- Class 180H insulation

EL Series Performance Curves

The below speed vs. force curves represent approximate continuous thrust ratings at indicated linear speed. Different types of servo amplifiers will offer varying motor

torque and thus actuator thrust. These values are at constant velocity and do not account for motor torque required for acceleration.

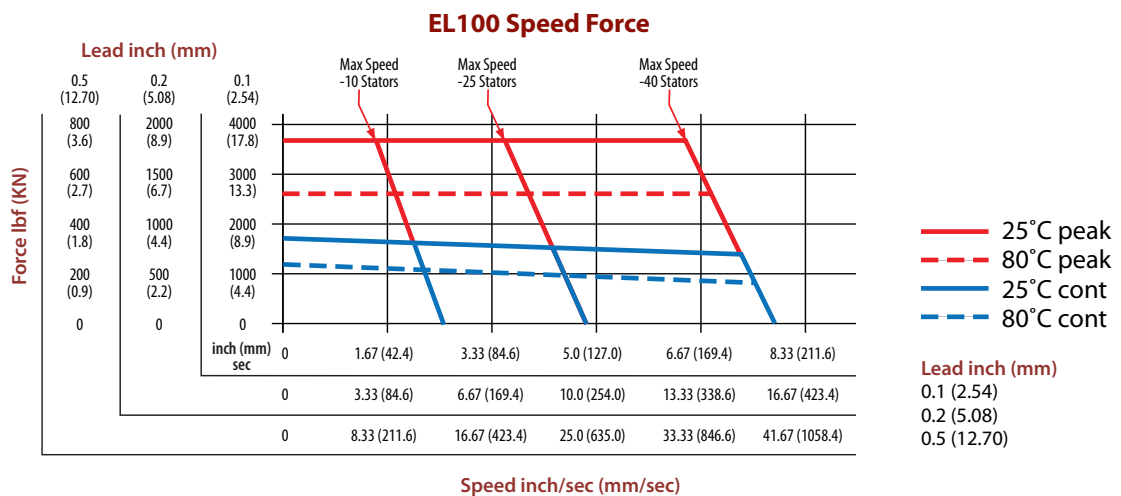
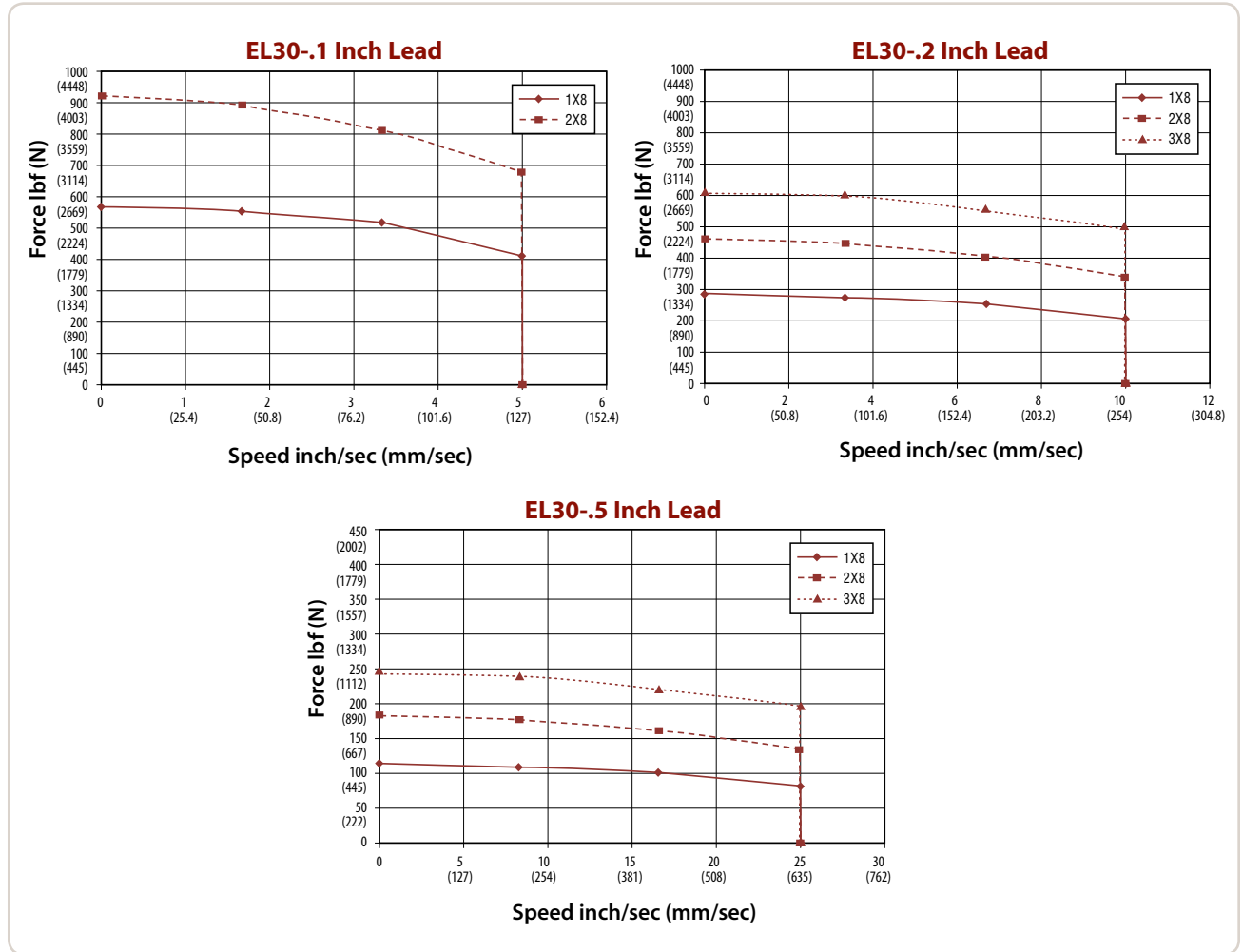

Hazardous Location EL Series Linear Actuators

EL Performance Specifications

Model No.	Frame Size in (mm)	Stroke (nominal)* in (mm)	Stator	Screw Lead in (mm)	Force Rating lb (N) 25 °C/80 °C	Max Velocity in/sec (mm/sec)	Approx* Cont. Motor Torque lb-in (N-m)	Maximum Static Load lb (N)	Armature Inertia Rating** lb-in-s ² (Kg-m ²)	Dynamic Load lb (N)	Weight (approx.) lb (kg)
EL30-0301	3.125 (79.0)	3 (75.0)		0.1 (2.54)	543/885/NA (2415/3936/NA)	5 (127.0)	10.8/17.6/NA (1.22/1.99/NA)	2700 (12010)	0.00319 (0.00036)	5516 (24536)	12 (5.4)
EL30-0302				0.2 (5.08)	271/442/NA (1205/1966/NA)	10 (254.0)				5800 (25798)	
EL30-0305				0.5 (12.7)	109/177/NA (485/787/NA)	25 (635.0)				4900 (21795)	
EL30-0601	3.125 (79.0)	6 (150.0)		0.1 (2.54)	543/885/NA (2415/3936/NA)	5 (127.0)	10.8/17.6/NA (1.22/1.99/NA)	2700 (12010)	0.00361 (0.00041)	5516 (24536)	15 (6.8)
EL30-0602				0.2 (5.08)	271/442/626 (1205/1966/2785)	10 (254.0)	10.8/17.6/24.9 (1.22/1.99/2.81)			5800 (25798)	
EL30-0605				0.5 (12.7)	109/177/250 (485/787/1112)	25 (635.0)	10.8/17.6/24.9 (1.22/1.99/2.81)			4900 (21795)	
EL100-0601	3.9 (100)	6 (150)	2A8-10 2B8-25 2C8-40 218-40 238.40 258.40 268.40	0.1 (2.54)	1806/1246 (8032/5542)	1.66 (4.16)	35.9 (24.8)	2700 (12010)	0.00361 (0.000408)	5516 (24536)	26.2 (11.9)
					1806/1246 (8032/5542)	41.66 (105.66)	35.9 (24.8)				
					1834/1266 (8160/5631)	6.66 (169.33)	36.5 (25.2)				
					1989/1373 (8848/6105)	6.66 (169.33)	39.6 (27.3)				
					2011/1387 (8943/6171)	6.66 (169.33)	40 (27.6)				
					1986/1371 (8835/6097)	6.66 (169.33)	39.5 (27.3)				
					2008/1385 (8930/6162)	6.66 (169.33)	39.9 (27.6)				
EL100-0602	3.9 (100)	6 (150)	2A8-10 2B8-25 2C8-40 218-40 238.40 258.40 268.40	0.2 (5.08)	903/623 (4016/2771)	3.33 (84.58)	35.9 (24.8)	2700 (12010)	0.00361 (0.000408)	5800 (25798)	26.2 (11.9)
					903/623 (4016/2771)	8.33 (211.58)	35.9 (24.8)				
					917/633 (4080/2815)	13.33 (338.58)	36.5 (25.2)				
					995/686 (4424/3053)	13.33 (338.58)	39.6 (27.3)				
					1005/694 (4472/3086)	13.33 (338.58)	40 (27.6)				
					993/685 (4417/3048)	13.33 (338.58)	39.5 (27.3)				
					1004/693 (4465/3081)	13.33 (338.58)	39.9 (27.6)				
EL100-0605	3.9 (100)	6 (150)	2A8-10 2B8-25 2C8-40 218-40 238.40 258.40 268.40	0.5 (12.70)	361/249 (1606/1108)	8.33 (211.58)	35.9 (24.8)	2700 (12010)	0.00361 (0.000408)	4900 (21795)	26.2 (11.9)
					361/249 (1606/1108)	20.83 (9529.08)	35.9 (24.8)				
					367/253 (1632/1126)	33.33 (846.58)	36.5 (25.2)				
					398/275 (1770/1221)	33.33 (846.58)	39.6 (27.3)				
					402/277 (1789/1234)	33.33 (846.58)	40 (27.6)				
					397/274 (1767/1219)	33.33 (846.58)	39.5 (27.3)				
					402/277 (1786/1232)	33.33 (846.58)	39.9 (27.6)				

* Please note that stroke mm are nominal dimensions. **Inertia +/- 5%
See page 13 for definition of terms.

Specifications subject to change without notice.

EL30 Series Mechanical/Electrical Specifications

Maximum Backlash (not preloaded)	in (mm)	0.004 (.10)															
Maximum Backlash (preloaded)	in (mm)	0.0															
Lead Accuracy	in/ft (mm/300 mm)	0.001 (.025)															
Maximum Radial Load	lb (N)	30 (134)															
Environmental Rating:	Standard	IP65															
Motor Stator-T4 Ratings		1A8	AB8	118	138	158	168	2A8	2B8	218	238	258	268	318*	338*	358*	368*
RMS SINUSOIDAL COMMUTATION																	
Continuous Motor Torque** (+/- 10% @ 25°C)	lbf-in (Nm)	10.8 (1.22)	10.8 (1.22)	10.9 (1.23)	10.8 (1.22)	10.7 (1.21)	10.3 (1.16)	17.4 (1.97)	17.4 (1.97)	17.6 (1.99)	17.6 (1.99)	17.5 (1.98)	17.5 (1.98)	25.2 (2.85)	24.9 (2.81)	23.6 (2.67)	23.6 (2.67)
Torque Constant (Kt)** (+/- 10% @ 25°C)	lbf-in/ (Nm/A)	1.1 (0.13)	1.1 (0.13)	4.4 (0.49)	8.7 (0.99)	15.5 (1.75)	17.5 (1.98)	1.1 (0.13)	1.1 (0.13)	4.4 (0.49)	8.7 (0.99)	15.5 (1.75)	17.5 (1.98)	4.4 (0.50)	8.7 (0.98)	15.7 (1.77)	17.6 (1.98)
Continuous Current Rating**	Amps	10.7	10.7	2.8	1.4	0.8	0.7	17.3	17.3	4.5	2.2	1.3	1.1	6.3	3.2	1.7	1.5
Peak Current Rating	Amps	21.3	21.3	5.6	2.8	1.5	1.3	34.5	34.5	9.0	4.5	2.5	2.2	12.7	6.4	3.4	3.0
TRAPEZOIDAL COMMUTATION																	
Continuous Motor Torque** (+/- 10% @ 80°C)	lbf-in (Nm)	10.3 (1.16)	10.3 (1.16)	10.4 (1.17)	10.3 (1.17)	10.2 (1.15)	9.8 (1.11)	16.6 (1.88)	16.6 (1.88)	16.8 (1.90)	16.8 (1.90)	16.7 (1.89)	16.7 (1.89)	24.1 (2.72)	23.8 (2.69)	22.5 (2.55)	22.6 (2.55)
Torque Constant (Kt)** (+/- 10% @ 80°C)	lbf-in/A (Nm/A)	0.9 (0.10)	0.9 (0.10)	3.4 (0.39)	6.8 (0.77)	12.1 (1.37)	13.6 (1.54)	0.9 (0.10)	0.9 (0.10)	3.4 (0.39)	6.8 (0.77)	12.1 (1.37)	13.6 (1.54)	3.5 (0.39)	6.8 (0.76)	12.2 (1.38)	13.7 (1.55)
Continuous Current Rating	Amps	13.1	13.1	3.4	1.7	0.9	0.8	21.1	21.1	5.5	2.8	1.5	1.4	7.8	3.9	2.1	1.8
Peak Current Rating	Amps	26.1	26.1	6.8	3.4	1.9	1.6	42.3	42.3	11.0	5.5	3.1	2.7	15.5	7.9	4.1	3.7
MOTOR STATOR DATA																	
Voltage Constant (Ke)** (+/- 10% @ 25°C)	Vrms/Krpm Vpk/Krpm	7.7 10.9	7.7 10.9	29.9 42.2	59.7 84.5	106.0 149.9	119.5 168.9	7.7 10.9	7.7 10.9	29.9 42.2	59.7 84.5	106.0 149.9	119.5 168.9	30.3 42.9	59.2 83.8	106.9 151.2	119.9 169.6
Pole Configuration		8	8	8	8	8	8	8	8	8	8	8	8	8	8	8	8
Resistance (L-L)(+/- 5% @ 80°C)	Ohms	0.19	0.19	2.8	11.2	36.3	49.6	0.08	0.08	1.1	4.5	14.1	18.0	0.65	2.6	9.3	11.6
Inductance (L-L)(+/- 5%)	mH	0.51	0.51	7.7	30.7	96.8	123.0	0.24	0.24	3.7	14.7	46.2	58.7	2.5	9.5	30.9	38.8
Mech Time Constant (tm)	ms min	6.6	6.6	6.5	6.5	6.7	7.2	2.6	2.6	2.6	2.6	2.6	2.6	1.5	1.5	1.7	1.7
	max	7.4	7.4	7.3	7.4	7.6	8.1	3.0	3.0	2.9	2.9	3.0	3.0	1.7	1.7	1.9	1.9
Electrical Time Constant (te)	ms	2.7	2.7	2.8	2.7	2.7	2.5	3.2	3.2	3.3	3.3	3.3	3.3	3.8	3.7	3.3	3.3
Damping Constant	lbf-in/krpm (N-m/krpm)	1.23 (0.14)															
Friction Torque	lbf-in (Nm)	2.00 (0.23)															
Bus Voltage	Vrms	24VDC	48VDC	115	230	400	460	24VDC	48VDC	115	230	400	460	115	230	400	460
Speed @ Bus Voltage	rpm	1500	3000	3000	3000	3000	3000	1500	3000	3000	3000	3000	3000	3000	3000	3000	3000
Insulation Class		180 (H)															
Temperature Class	°C	T4 = 135°C T3A = 180°C															
Connectors		Potted NPT Connectors Only															

For amplifiers using peak sinusoidal ratings, multiply RMS sinusoidal Kt by .707 and current by 1.414. Specifications reflect 80°C test environment

Specifications subject to change without notice.

*Not available with 3" stroke

**For T3A Temperature Class multiply Kt & Ke ratings by 0.83; Continuous Current by 1.245; Continuous Torque by 1.095

Hazardous Location EL Series Linear Actuators

EL100 Series Mechanical/Electrical Specifications

Nominal Backlash	in (mm)	0.004 (.10)						
Maximum Backlash (preloaded)	in (mm)	0.0						
Lead Accuracy in/ft	(mm/300 mm)	0.001 (.025)						
Maximum Radial Load	lb (N)	40 (179)						
Environmental Rating	Standard	IP66						
Motor Stator Ambient Temperature		2A8-10 25°/80°C	2B8-25 25°/80°C	2C8-40 25°/80°C	218-40 25°/80°C	238-40 25°/80°C	258-40 25°/80°C	268-40 25°/80°C
RMS SINUSOIDAL COMMUTATION DATA								
Continuous Motor Torque	lbf-in (Nm)	35.9/24.8 (4.06/2.80)	35.9/24.8 (4.06/2.80)	36.5/25.2 (4.12/2.85)	39.6/27.3 (4.47/3.09)	40.0/27.6 (4.52/3.12)	39.5/27.3 (4.46/3.08)	39.9/27.6 (4.51/3.11)
Torque Constant @ 25°C (Kt)	lbf-in/(Nm/A)	1.7 (0.19)	1.7 (0.19)	2.6 (0.30)	3.2 (0.37)	6.6 (0.75)	11.6 (1.31)	13.2 (1.50)
Continuous Current Rating (IG)	Amps	23.6/16.3	23.6/16.3	15.6/10.7	13.6/9.4	6.8/4.7	3.8/2.6	3.4/2.3
Peak Current Rating	Amps	47.1/32.5	47.1/32.5	31.1/21.5	27.3/18.8	13.5/9.3	7.6/5.3	6.7/4.7
TRAPEZOIDAL COMMUTATION DATA								
Continuous Motor Torque	lbf-in (Nm)	34.3/23.7 (3.88/2.67)	34.3/23.7 (3.88/2.67)	34.9/24.0 (3.94/2.72)	37.8/26.1 (4.27/2.95)	38.2/26.4 (4.32/2.98)	37.7/26.0 (4.26/2.94)	38.1/26.3 (4.31/2.97)
Torque Constant @ 25°C (Kt)	lbf-in/A (Nm/A)	1.3 (0.15)	1.3 (0.15)	2.0 (0.23)	2.5 (0.29)	5.2 (0.58)	9.0 (1.02)	10.3 (1.17)
Continuous Current Rating (IG)	Amps	28.9/19.9	28.9/19.9	19.1/13.2	16.7/11.5	8.3/5.7	4.7/3.2	4.1/2.8
Peak Current Rating	Amps	57.7/39.8	57.7/39.8	38.1/26.3	33.4/23.1	16.5/11.4	9.4/6.5	8.3/5.7
MOTOR STATOR DATA								
Voltage Constant @ 25°C (Ke)	Vrms/Krpm	11.6	11.6	17.9	22.1	45.2	78.9	90.4
	Vpk/Krpm	16.5	16.5	25.3	31.3	64.0	111.6	127.9
Pole Configuration		8	8	8	8	8	8	8
Resistance (L-L)	Ohms	0.10	0.10	0.20	0.30	1.2	3.8	4.86
Inductance (L-L)	mH	0.79	0.79	1.9	2.93	12.2	37.2	48.9
Brake Inertia	lbf-in-sec ² (kg-cm ²)	0.00047 (.53)						
Brake Current @24 VDC +/- 10%	A	0.5						
Brake Holding Torque - Dry	lbf-in (Nm/A)	70 (8)						
Brake Engage/Disengage Time	ms	25/50						
Mechanical Time Constant (tm)	ms	1.7	1.7	1.7	1.4	1.4	1.4	1.4
Electrical Time Constant (te)	ms	7.9	7.9	8.2	9.9	10.1	9.9	10.1
Bus Voltage	Vrms	24 VDC	48 VDC	120 VDC	115 VAC	230 VAC	400 VAC	460 VAC
Speed @ Bus Voltage	rpm	1000	2500	4000	4000	4000	4000	4000
Insulation Class		180 (H)						
Ambient Temperature Rating		-29° C to 93° C						
CSA/ATEX Temperature Class		T3, 200° C Maximum Allowable Surface Temperature						
Continuous Force Ratings		25°/80°C	25°/80°C	25°/80°C	25°/80°C	25°/80°C	25°/80°C	25°/80°C
0.1 inch lead EL100-0601	lbf (N)	1806/1246 8032/5542	1806/1246 8032/5542	1834/1266 8160/5631	1989/1373 8848/6105	2011/1387 8943/6171	1986/1371 8835/6097	2008/1385 8930/6162
0.2 inch lead EL100-0602	lbf (N)	903/623 4016/2771	903/623 4016/2771	917/633 4080/2815	995/686 4424/3053	1005/694 4472/3086	993/685 4417/3048	1004/693 4465/3081
0.5 inch lead EL100-0605	lbf (N)	361/249 1606/1108	361/249 1606/1108	367/253 1632/1126	398/275 1770/1221	402/277 1789/1234	397/274 1767/1219	402/277 1786/1232

For amplifiers using peak sinusoidal ratings, multiply RMS sinusoidal Kt by 0.707, and peak current by 1.414. All temperature ratings ambient.

Specifications subject to change without notice.

Actuator Rod End Options

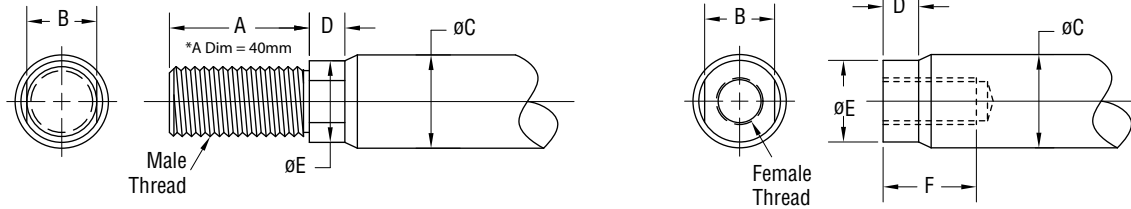

	A	B	øC	D	øE	F	Male U.S.	Male Metric	Female U.S.	Female Metric
EL30 in (mm)	0.750 (19.1)	0.500 (12.7)	0.625 (15.9)	0.281 (7.1)	0.562 (14.3)	0.750 (19.1)	7/16 - 20 UNF - 2A	M12 x 1.75* 6g	7/16 - 20 UNF - 2B	M10 x 1.5 6h

EL30 Clevis Mount

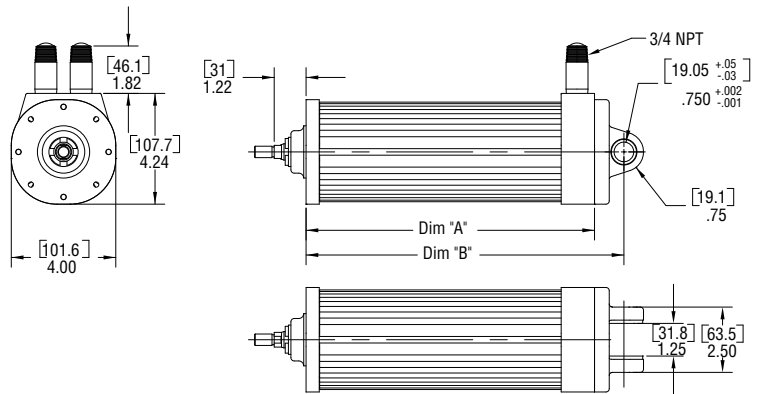

EL30 Front Flange Mount

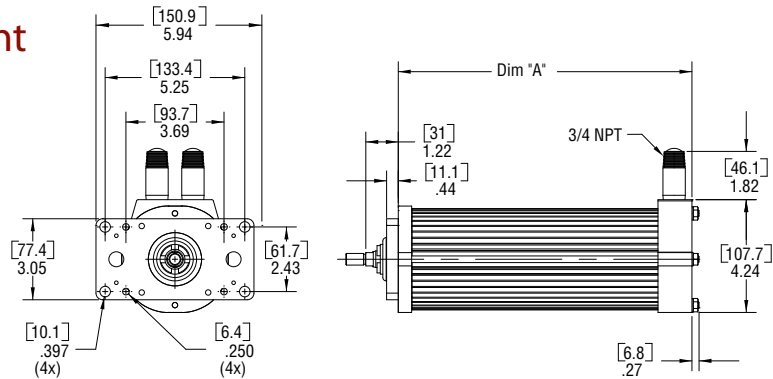

EL30 Base Unit

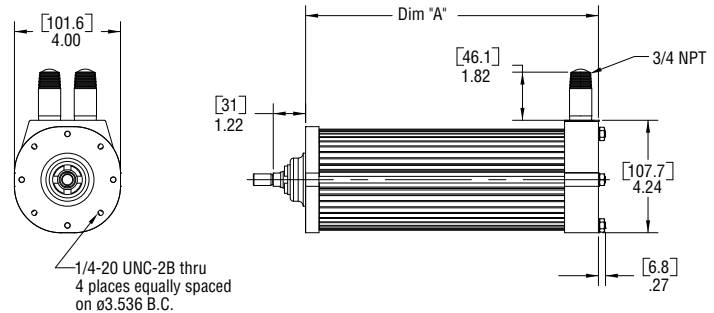

Dim	3" (76.2 mm) Stroke	6" (152.4 mm) Stroke
A	8.6 (218)	11.0 (281)
B	9.7 (246)	12.2 (309)

Hazardous Location EL Series Linear Actuators

EL100 Dimensions

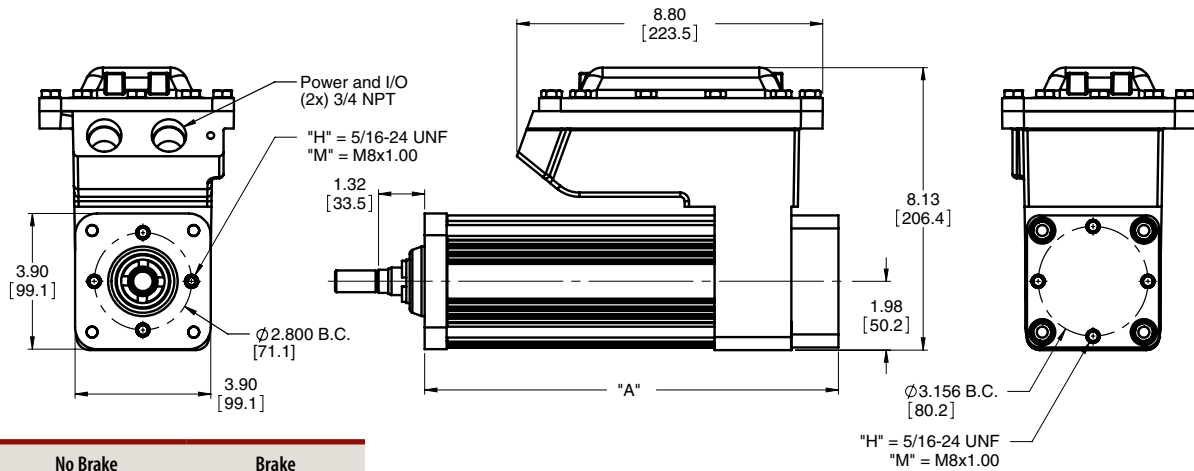

Dim	No Brake	Brake
A	11.9 (302.3)	14.2 (360.8)

EL100 Actuator Rod End Options

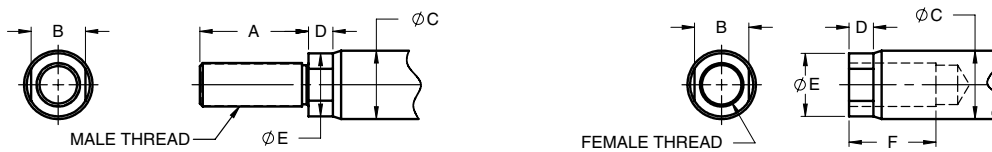

	A	B	ØC	D	ØE	F	Male "M" Inch	Male "A" Metric	Female "F" Inch	Female "B" Metric
EL100 in (mm)	1.250 (31.8)	0.625 (17.0)	0.787 (20.0)	0.281 (7.1)	0.725 (18.4)	1.000 (25.4)	1/2 - 20 UNF - 2A	M16 x 1.5 6g	1/2 - 20 UNF - 2B	M16 x 1.5 6h

EL100 Front Flange or Clevis Mount

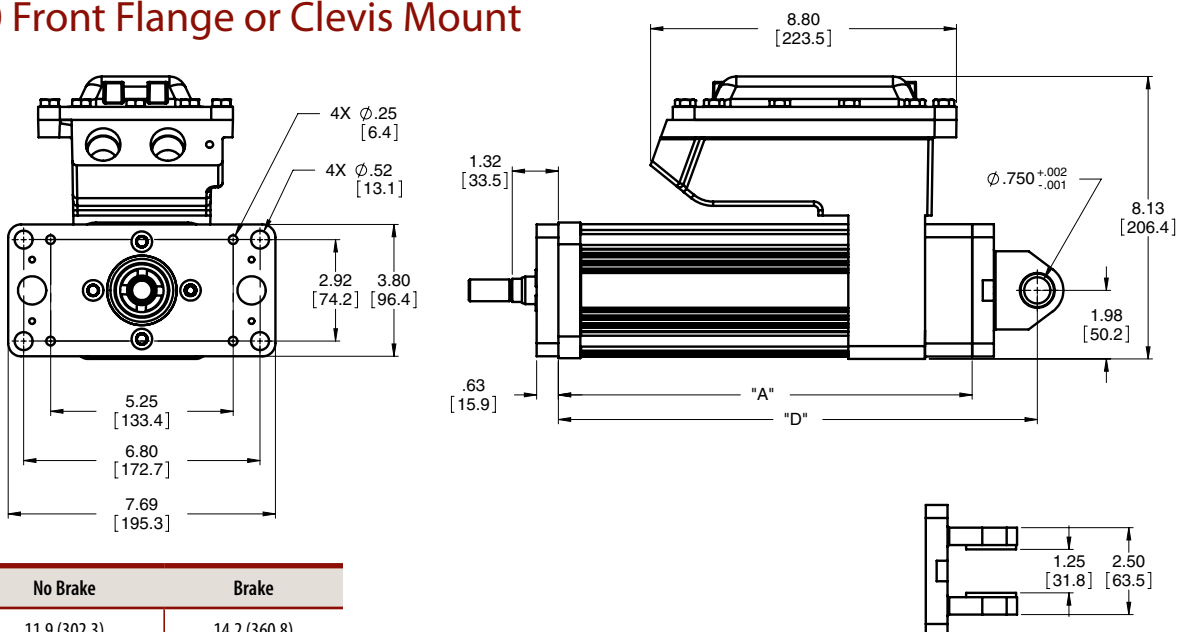

Dim	No Brake	Brake
A	11.9 (302.3)	14.2 (360.8)
D	13.77 (349.9)	16.7 (408.2)

EL100 Terminal Box Wiring

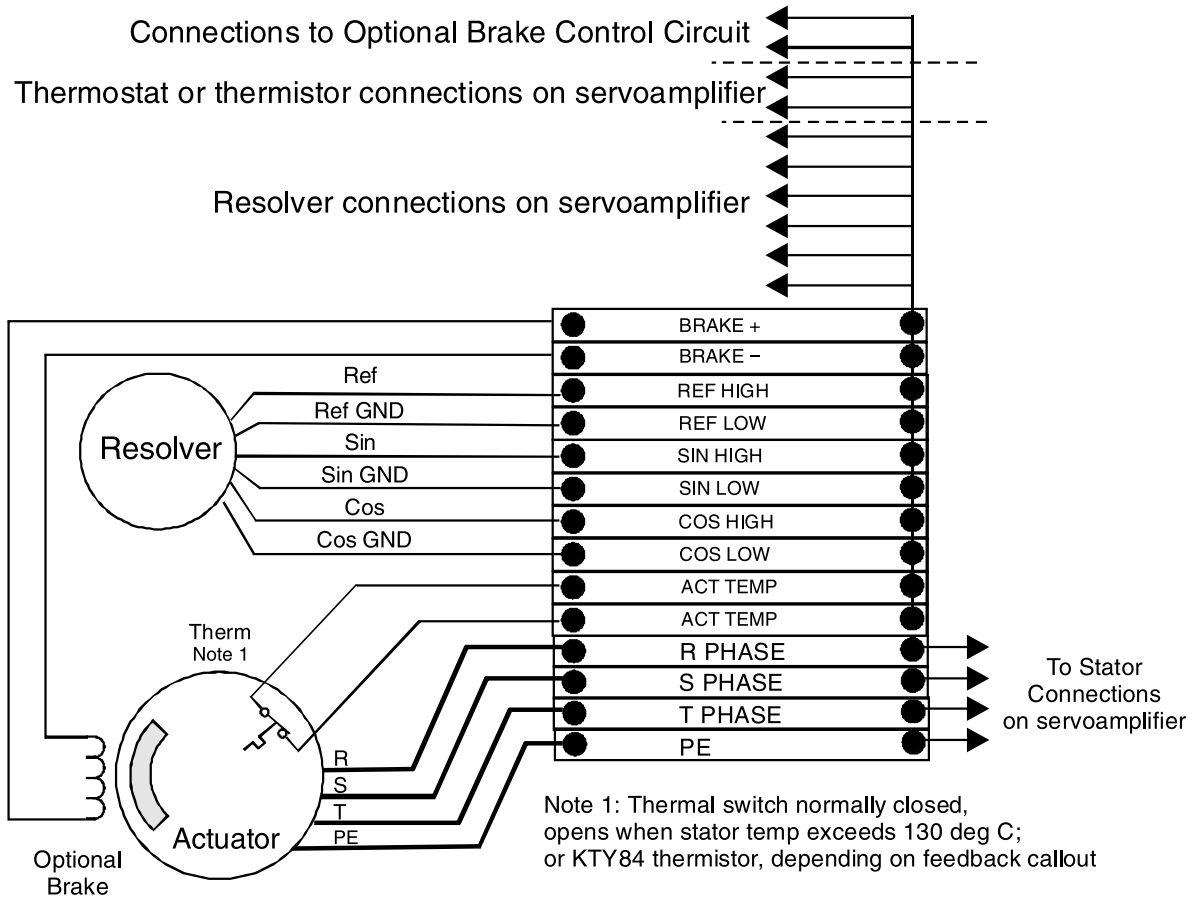

EL30 = Model Series

AA = Frame Size

30 = 3 inch (80 mm) nominal

BB = Nominal Stroke Length

03 = 3 inch (75 mm) stroke
 06 = 6 inch (150 mm) stroke
 XX = Special stroke not to exceed 6 inch (150 mm)

CC = Screw Lead

01 = 0.1 inch lead
 02 = 0.2 inch lead
 05 = 0.5 inch lead
 XX = Special

DDD = Connector Options

N## = Potted NPT with flying leads
 ## = Length of flying leads in feet (not to exceed 99') Consult Exlar application engineering if longer length is needed.

E = Mounting Options

F = Front Flange
 C = Rear Clevis
 H = Threaded Face
 X = Special Mounting

F = Rod Ends

M = Male, US std thread
 A = Male, Metric std thread
 F = Female, US std thread
 B = Female, Metric std thread

GGG = FeedbackType

(Also specify the Amplifier/Drive Model being used when ordering) -- Standard Resolver
 - Size 15 1024 line (2068 cts) per rev, two phase resolver

XX1 = Custom Feedback - Wiring and feedback device information must be provided and new feedback callout will be created - Please consult application engineering. Resolver only.

AB6 = Allen-Bradley/Rockwell - Standard Resolver

AM3 = Advanced Motion Control - Standard Resolver

AP1 = API Controls - Standard Resolver

BD2 = Baldor - Standard Resolver

BM2 = Baumuller - Standard Resolver

BR1 = B&R Automation - Standard Resolver

CO2 = Copley Controls - Standard Resolver

CT5 = Standard Resolver - FM/UM/EZ motor wiring w/M23 euro connectors for 'M' option

DT2 = Delta Tau Data Systems - Standard Resolver

EL1 = Elmo Motion Control - Standard Resolver

EX4 = Exlar - Standard Resolver

IF1 = Infranor - Standard Resolver

IN6 = Indramat/Bosch-Rexroth - Standard Resolver

JT1 = Jetter Technologies - Standard Resolver

KM5 = Kollmorgen/Danaher - Standard Resolver

LZ5 = Lenze/AC Tech - Standard Resolver

MD1 = Modicon - Standard Resolver

MG1 = Moog - Standard Resolver

MN4 = Momentum - Standard Resolver

MX1 = Metronix - Standard Resolver

OR1 = Ormec - Standard Resolver

PC7 = Parker - Standard Resolver - European only

PC0 = Parker - Standard Resolver - US Only

PS3 = Pacific Scientific - Standard Resolver

SM2 = Siemens - Standard Resolver

SW1 = SEW/Eurodrive - Standard Resolver

WD1 = Whedco/Fanuc - Standard Resolver

HHH = Motor Stator all 8 pole

1A8 = 1 stack, 24 Vrms

218 = 2 stack, 115 Vrms

1B8 = 1 stack, 48 Vrms

238 = 2 stack, 230 Vrms

118 = 1 stack, 115 Vrms

258 = 2 stack, 400 Vrms

138 = 1 stack, 230 Vrms

268 = 2 stack, 460 Vrms

158 = 1 stack, 400 Vrms

318 = 3 stack, 115 Vrms²

168 = 1 stack, 460 Vrms

338 = 3 stack, 230 Vrms²

2A8 = 2 stack, 24 Vrms

358 = 3 stack, 400 Vrms²

2B8 = 2 stack, 48 Vrms

368 = 3 stack, 460 Vrms²

II = Motor Speed

01-99 = Two digit number - rated speed in rpm x 100

JJJ = Hazardous Location Temperature Rating

T3A = 180° C (Samarium Cobalt magnets)

T4 = 135° C (Neodymium-Iron-Boron magnets)

XX = Optional Speed & Mechanical

Designations - Multiples possible

XL = Special Lubrication

PF = Preloaded follower¹

XT = Special travel option

= Part No. Designator for Specials

Optional 5 digit assigned part number to designate unique model numbers for specials.

Notes:

- The dynamic load rating of zero backlash, preloaded screws is 63% of the dynamic load rating of the standard non-preloaded screws. The calculated travel life of a preloaded screw will be 25% of the calculated travel life of the same size and lead of a non-preloaded screw.
- Not available with 3" stroke.

EL100 = Model Series

CC = Stroke Length
 06 = 5.9 inch (150 mm)

DD = Roller Screw Lead (Linear Travel per Screw Revolution)

01 = 0.1 in/rev (2.54 mm/rev)
 02 = 0.2 in/rev (5.08 mm/rev)
 05 = 0.5 in/rev (12.7 mm/rev)
 XX = Special Lead

E = Connections

S = Terminal strips with 3/4" NPT port access, single row

F = Mounting

H = Threaded front and rear face, US standard thread
 N = Threaded front and rear face, metric thread
 B = Front and rear flange
 F = Standard front flange
 C = Standard rear clevis
 R = Rear flange
 X = Special flange, clevis or threaded face mount

G = Rod End

M = Male, US standard thread
 A = Male, metric thread
 F = Female, US standard thread
 B = Female, metric thread
 W = Male, US standard thread 17-4 SS
 R = Male, metric thread 17-4 SS
 V = Female, US standard thread 17-4 SS
 L = Female, metric thread 17-4 SS
 X = Special rod end (consult Exlar)

HHH = Controller Feedback Option

XX1 = Custom Feedback. Resolver only. Consult Exlar
 AB6 = Allen-Bradley/Rockwell - standard resolver
 AM3 = Advanced Motion Control - standard resolver
 AP1 = API Controls - standard resolver
 BD2 = Baldor - standard resolver
 BM2 = Baumuller - standard resolver
 BR1 = B&R Automation
 CT5 = Control Techniques - standard resolver
 CO2 = Copely Controls - standard resolver
 DT2 = Delta Tau Data Systems - standard resolver
 EL1 = Elmo Motion Control - standard resolver
 EX4 = Exlar - standard resolver
 IF1 = Infranor - standard resolver
 IN6 = Indramat/Bosch-Rexroth - standard resolver
 JT1 = Jetter Technologies - standard resolver
 KM5 = Kollmorgen/Danaher - standard resolver
 LZ5 = Lenze/AC Tech - standard resolver
 MD1 = Modicon - standard resolver
 MG1 = Moog - standard resolver
 MN4 = Momentum - Standard Resolver
 MX1 = Metronix - standard resolver
 OR1 = Ormec - standard resolver
 PC7 = Parker - standard resolver - European only
 PC0 = Parker - standard resolver - US only
 PS3 = Pacific Scientific - standard resolver
 SM2 = Siemens - standard resolver
 SW1 = SEW/Eurodrive - standard resolver
 WD1 = Whedco/Fanuc - standard resolver

I = Motor Stacks

2 = 2 stack motor

J = Rated Voltage

A = 24 VDC
 B = 48 VDC
 C = 120 VDC
 1 = 115 Volt RMS
 3 = 230 Volt RMS
 5 = 400 Volt RMS
 6 = 460 Volt RMS
 X = Special voltage rating - not to exceed 460 Volt RMS

K = Motor Poles

8 = 8 Pole Motor

LL = Rated Motor Speed at Rated Voltage

01 - 99 = Two digit number x 100 = rated RPM

MM = Mechanical Option (Multiple options may apply - separated by "-")

XL = Special lubrication, Mobilgrease 28 or other (please specify)
 PF = Pre-loaded roller screw follower¹
 AR = External anti-rotate assembly (requires flange mount option)
 RB = Rear brake
 XT = Special housing option (see options below)
 Hard anodized aluminum motor housing parts
 Epoxy coated terminal housing (casting)

NN = Haz Loc Temp Rating

T3 = 200° C max allowable surface temperature

= Part No. Designator for Specials

Optional 5 digit assigned part number to designate unique model numbers for specials.

Notes:

1. The dynamic load rating of zero backlash, preloaded screws is 63% of the dynamic load rating of the standard non-preloaded screws. The calculated travel life of a preloaded screw will be 25% of the calculated travel life of the same size and lead of a non-preloaded screw.