

Exlar GS Series Linear Actuator Family

The GS Series linear actuator family offers you two grades of actuator to provide cost effective options in order to meet your application's requirements. View the chart below to compare the GSX and GSM models.

All GS Series actuators use a specially designed roller screw mechanism for converting electric motor power into linear motion within the actuator. Planetary rollers assembled around the actuator's extending rod follow threads which are precisely machined on the inside surface of the actuator's hollow armature. Linear motion is produced in precise synchronization with the armature rotation. Because this roller screw mechanism has an inherently larger cumulative contact surface, these actuators have a much longer working life, and can handle heavier loads at higher speeds than is possible from a similarly sized unit built around a ball screw system.

Exlar's T-LAM segmented lamination stator technology delivers higher continuous motor torque than is available in traditionally wound motors. T-LAM technology consists of stator segments, each containing individual phase wiring for maximum motor performance. The improved efficiencies of the GSX Series are a result of the limited heat generation qualities inherent in the segmented stator design as seen above. The elimination of end turns in the stator, and use of thermally conductive potting removes the parts most susceptible to failure in a traditional stator. Other design advantages include:

- Neodymium-iron-boron magnets provide high flux density and maximum motor torque.
- Thermally conductive potting of the entire stator provides increased heat dissipation and provides protection from contamination in oil-cooled units.
- Each stator segment contains individual phase wiring. External winding of individual segments provides maximum slot fill for maximum motor performance.
- Motors with T-LAM technology have Class 180 H insulation systems compliant with UL requirements. UL recognized component.
- Motors with T-LAM technology are CE compliant

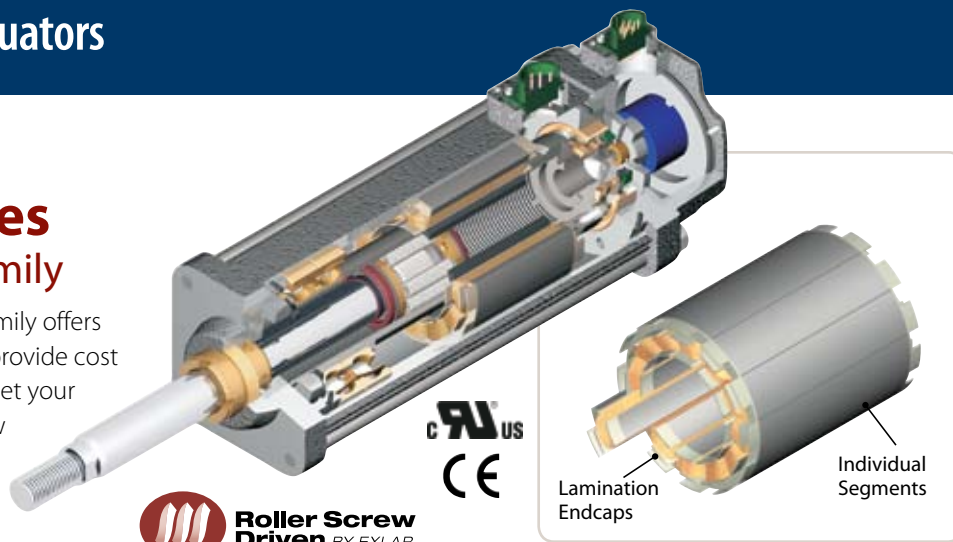

The Actuator & Motor, All in one Compact Unit

With other actuator technologies, customers are usually responsible for engineering the completed linear motion system. This usually includes purchasing the motor, gear reducer, timing belt, mounting hardware, flexible couplings, etc. separately. Then they all must be assembled to perform properly in a given application.

GS Series actuators eliminate all this systems engineering. These units are single, fully integrated component packages – much smaller than traditional rotary-to-linear conversion mechanisms.

Designed for Closed Loop Servo Systems

Their brushless servo design means GS Series units can be used in advanced closed-loop servo systems when velocity and positioning is required. Position feedback can be delivered in a number of different forms. These include resolvers, encoders or internally mounted linear position feedback sensors.

GSX and GSM Differences	GSX (pg 4)	GSM (pg 38)
Ingress Protection	IP65	IP54 (IP65 optional)
No. of Stacks	1, 2, 3	1, 2
Life BSY (Ball Screw Years)	15X	2 to 5X
Oil Cooling	Yes	No
Food Grade Paint	Yes	No
Electroless Nickel Housing	Yes	Yes
Stainless Steel Case	Yes	No
Hard Coat Anodized	Yes	Yes
LVDT FB	Yes (except 2" frame)	Yes (except 2" frame)
5.5 in. Frame	Yes	No
7 in. Frame	Yes	No
Force (lbf)	92 - 15,000	92 - 3,966
1.0 Lead	50 & 60 only	No
Rear Brake	all	all
Speeds (ips)	5 - 40	5 - 37.5
Electroless Nickel Connectors	Yes	Yes

Exlar GSX Series The Highest Performance and Longest Life Solution

For applications that require long life and continuous duty, even in harsh environments the GSX Series actuator offers a robust solution. The life of the GSX Series can exceed that of a ball screw actuator by 15X while delivering high speeds and high forces. This compact package has all the advantages that our GS Series offers.

Sealed for Long Life with Minimum Maintenance

GSX Series actuators have strong advantages whenever outside contaminants are an issue. In most rotary-to-linear devices, critical mechanisms are exposed to the environment. Thus, they must be frequently inspected, cleaned and lubricated.

In contrast, the converting components in all Exlar GSX units are mounted within the sealed motor housing. With a simple bushing and seal arrangement on the smooth extending rod, abrasive particles or other contaminants are prevented from reaching the actuator's critical mechanisms. This assures trouble-free operation even in the most harsh environments.

Lubrication requirements are minimal. GSX actuators can be lubricated with either grease or recirculated oil. Grease lubricated units will run up to 10,000 hours without regreasing. Recirculated oil systems eliminate this type of maintenance altogether. A GSX Series actuator with a properly operating recirculating oil system will operate indefinitely without any other lubrication requirements.

Available in Five Frame Sizes

2" GSX20 3" GSX30 4" GSX40
5" GSX50 7" GSX60

If you need a custom design, Exlar's Application Engineering department will work with you to engineer a solution specifically tailored to your application.



GSX Series



Feature	Standard	Optional
External anti-rotate mechanism	No	Yes
Internal Anti-rotate	No	Yes
Pre-loaded follower	No	Yes
Electric brake	No	Yes
External End switches	No	Yes
Connectors	MS or Threaded Circular Style Connectors	Electroless Nickel Connectors/ Male NPT with Potted Leads/ Manufacturers Connectors
Mounting Style	Extended Tie Rods, Side Tapped Mounting Holes, Trunnion, Rear Clevis, Front or Rear Flange	Custom Mountings
Rod End	Male or Female: U.S. Standard or Metric	Specials Available To Meet OEM Requirements
Lubrication	Greased, Oil Connection Ports are Built-in for Customer Supplied Recirculated Oil Lubrication	Specials Available To Meet OEM Requirements
Primary Feedback	Standard Encoders or Resolvers to Meet Most Amplifier Requirements	Custom Feedback
Absolute Linear Feedback	No	ICT, including signal conditioner

GSX Series Linear Actuators

Exlar GSX Series Linear Actuators Applications Include:

Hydraulic cylinder replacement
 Ball screw replacement
 Pneumatic cylinder replacement
 Chip and wafer handling
 Automated flexible fixturing
 Dispensers
 Machine tool
 Automated assembly
 Parts clamping
 Automatic tool changers
 Volumetric pumps

Medical equipment
 Conveyor diverters / gates
 Plastics equipment
 Cut-offs
 Die cutters
 Packaging machinery
 Entertainment
 Sawmill equipment
 Open / close doors
 Fillers
 Formers
 Precision grinders
 Indexing stages

Lifts
 Product sorting
 Material cutting
 Material handling
 Riveting / fastening / joining
 Molding
 Volumetric pumps
 Semiconductor
 Pick and place systems
 Robot manipulator arms
 Simulators
 Precision valve control

Ventilation control systems
 Pressing
 Process control
 Tube bending
 Welding
 Stamping
 Test stands
 Tension control
 Web guidance
 Wire winding
 Food Processing

Repeatable force, reliable positioning accuracy, and flexible control make GSX actuators a perfect fit for assembly presses or test stands.

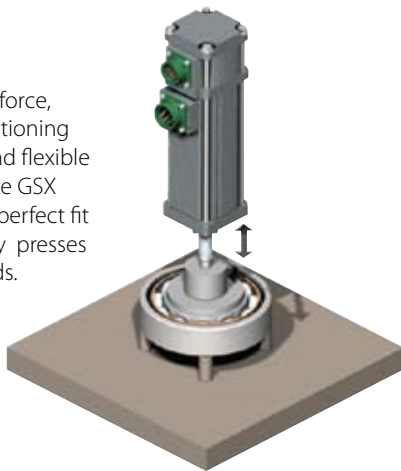

Because they cycle quickly and can be synchronized to line speeds, Exlar actuators produce dramatic improvements in web control applications.

In clean room applications like those common to semiconductor manufacturing, the compact design of our GSX Series saves critical space.

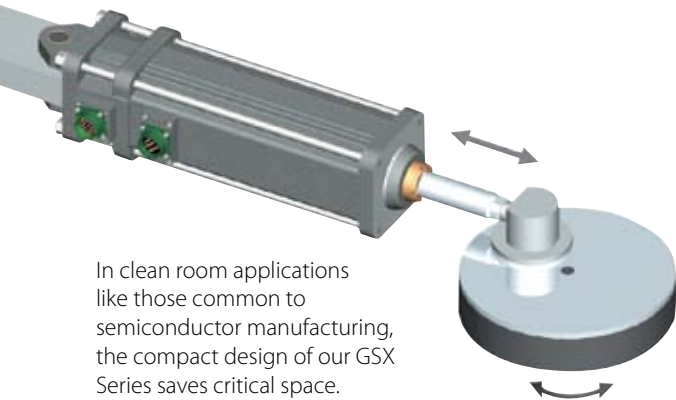

Repeatable force control plus positioning accuracy extends the life of costly tools when Exlar linear actuators are used in precision clamping applications.



GSX Series Speed vs. Force Curves

These charts represent typical linear speed versus linear force curves for the GSX actuators using common brushless motor amplifiers. The GSX Series are compatible with many different brushless motor amplifiers, and differences in the

performance ratings of these amplifiers can alter the actuator's performance. Thus, the curves below should be used for estimation only (Further information is available by contacting Exlar Application Engineering.)

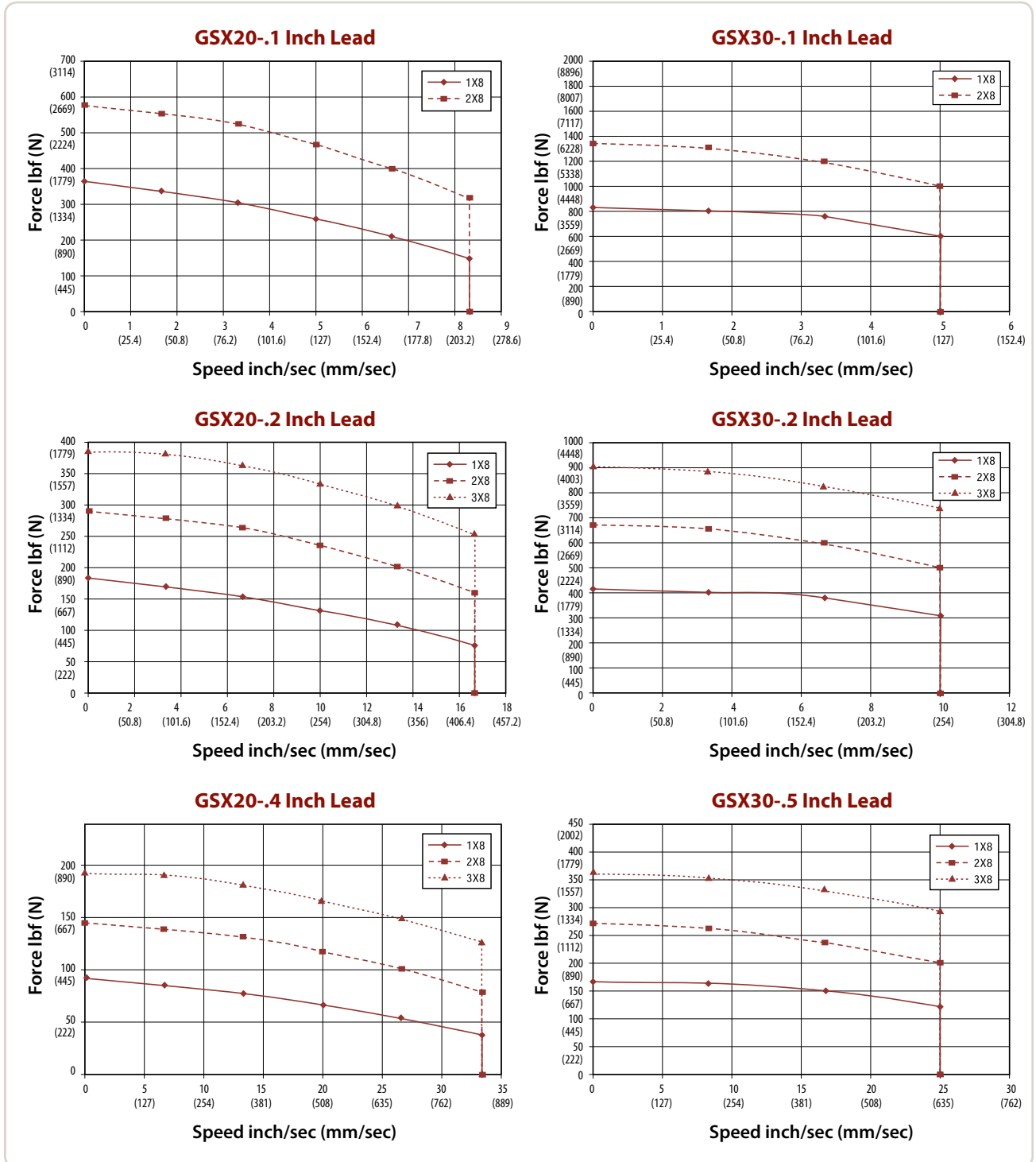

Test data derived using NEMA recommended aluminum heatsink 10" x 10" x 1/4" for GSX20 and 10" x 10" x 3/8" for GSX30

GSX Series Speed vs. Force Curves

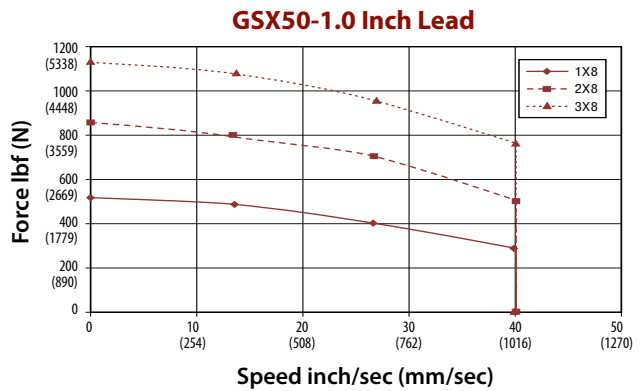
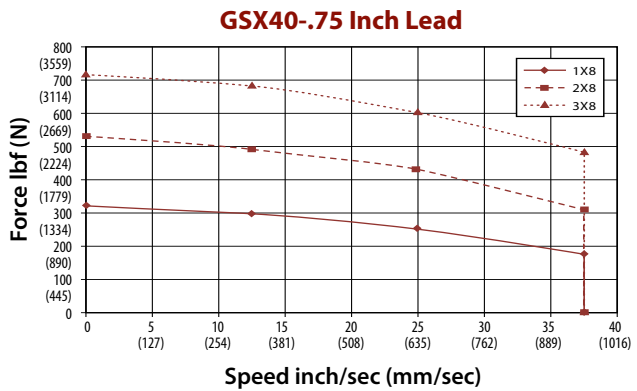
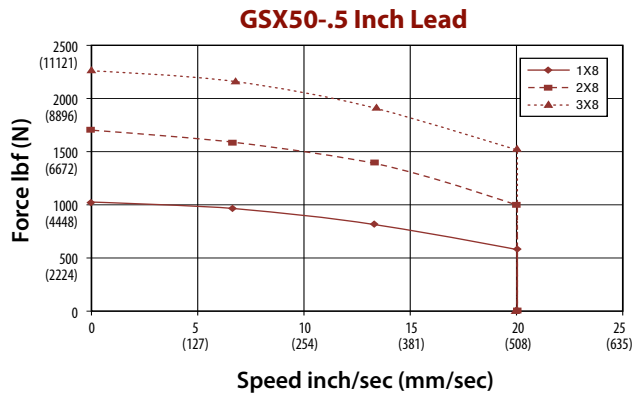
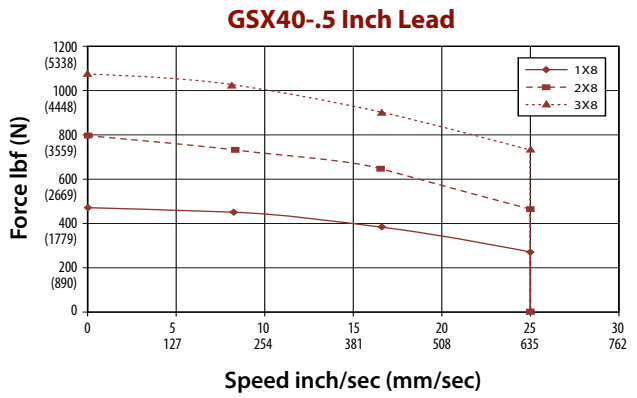
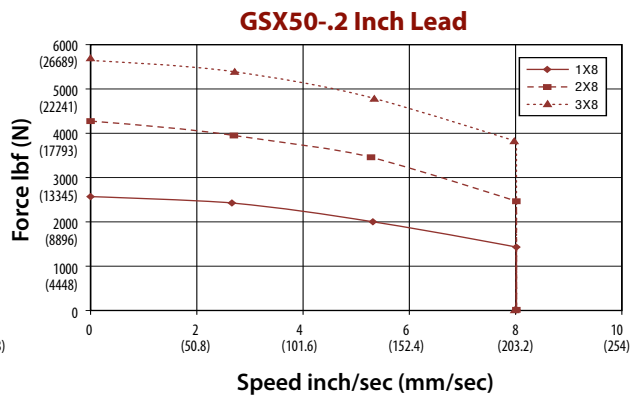
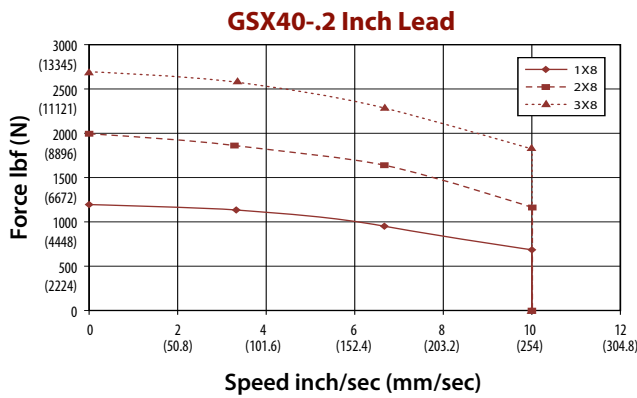
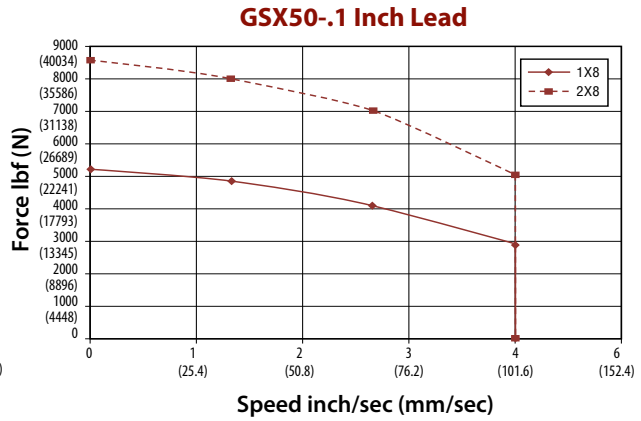
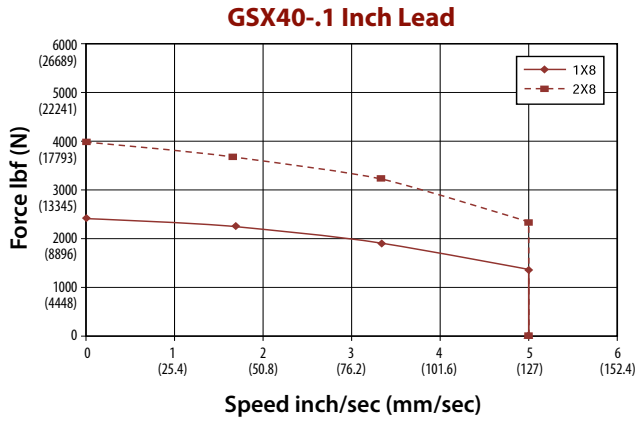

Test data derived using NEMA recommended aluminum heatsink 12" x 12" x 1/2" for GSX40 and 12" x 12" x 1/2" for GSX50

GSX Series Speed vs. Force Curves

These charts represent typical linear speed versus linear force curves for GSX actuators using common brushless motor amplifiers. The GSX Series are compatible with many different brushless motor amplifiers, and differences in the

performance ratings of these amplifiers can alter the actuator's performance. Thus, the curves below should be used for estimation only. (Further information is available by contacting Exlar Application Engineering.)

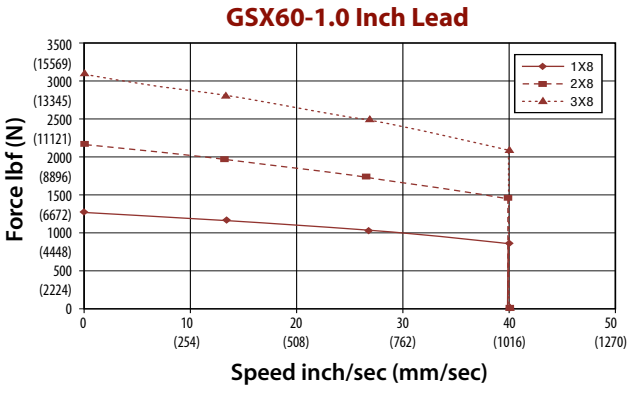
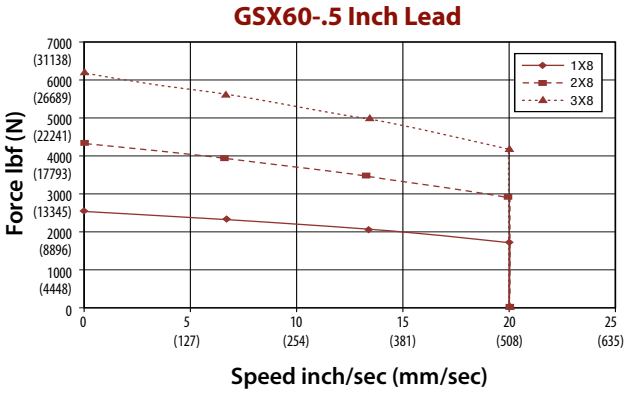
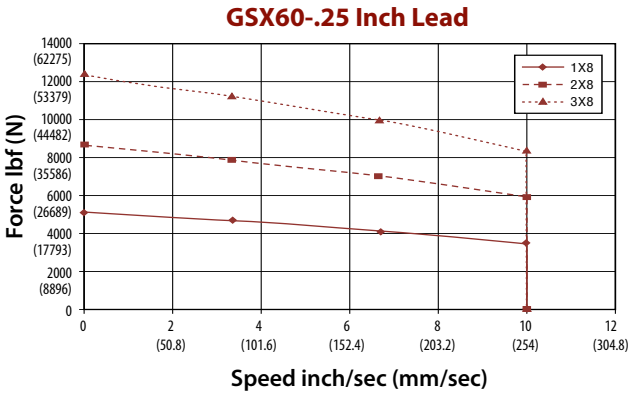

GSX Series Linear Actuators

GSX Series Lifetime Curves

The L_{10} expected life of a roller screw linear actuator is expressed as the linear travel distance that 90% of properly maintained roller screws manufactured are expected to meet or exceed. For higher than 90% reliability, the result should be multiplied by the following factors: 95% x 0.62; 96% x 0.53; 97% x 0.44; 98% x 0.33; 99% x 0.21. This is not a guarantee and these charts should be used for estimation purposes only.

The underlying formula that defines this value is:

Travel life in millions of inches, where:

C = Dynamic load rating (lbf)

F = Cubic mean applied load (lbf) $L_{10} = \left(\frac{C}{F}\right)^3 \times S =$

S = Roller screws lead (inches)

All curves represent properly lubricated and maintained actuators.

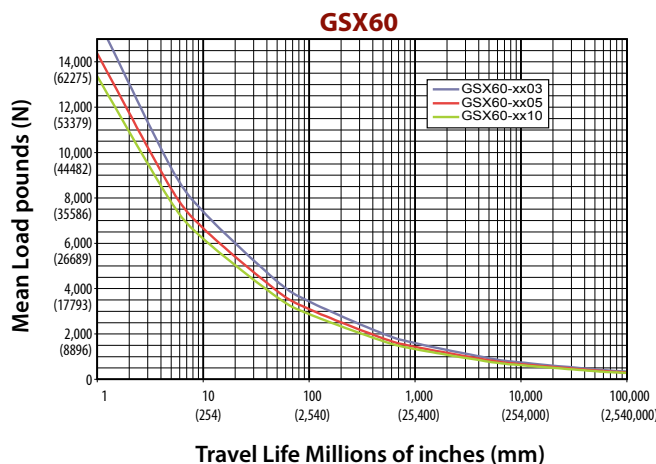
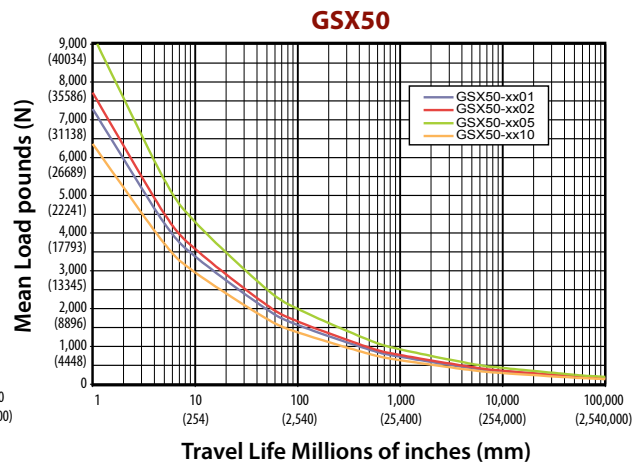
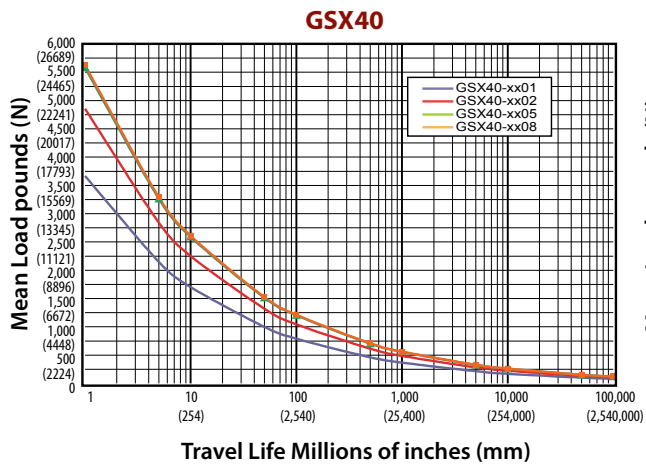
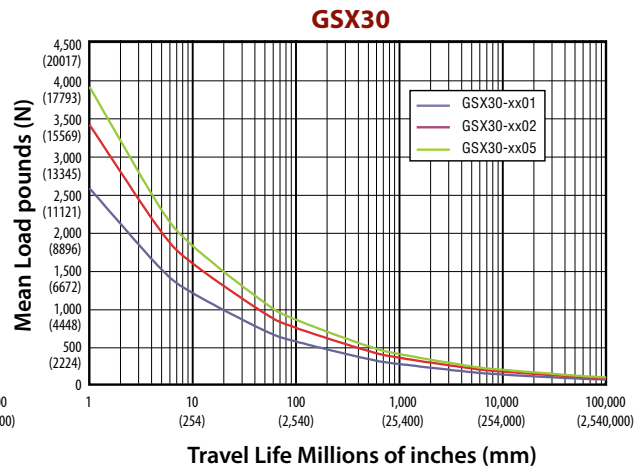
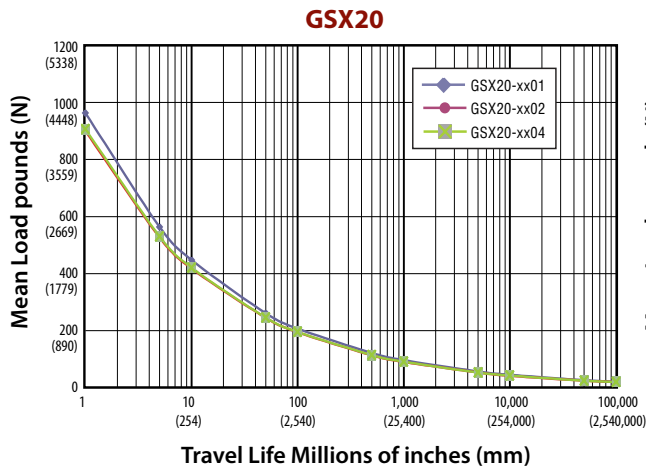

GSX20 & GSX30 Performance Specifications

Model No.	Frame Size in (mm)	Stroke (nominal)* in (mm)	Screw Lead in (mm)	Continuous Force Rating lb (N) 1/2/3 stack	Max Velocity in/sec (mm/sec)	Continuous Motor Torque lb-in (N-m)	Maximum Static Load lb (N)	Armature Inertia** lb-in-s ² (Kg-m ²)	Dynamic Load Rating lb (N)	Weight (approx.) lb (kg)
GSX20-0301	2.25 (57)	3 (75)	0.1 (2.54)	367/578/NA (1632/2571/NA)	8.33 (211.67)	7.3/11.5/NA (0.82/1.30/NA)	1250 (5560)	0.00101 (0.000114)	2075 (9230)	6.5 (2.9)
GSX20-0302			0.2 (5.08)	183/289/NA (814/1286/NA)	16.77 (423.33)	7.3/11.5/NA (0.82/1.30/NA)			1540 (6850)	
GSX20-0304			0.4 (10.16)	92/145/NA (409/645/NA)	33.33 (846.67)	7.3/11.5/NA (0.82/1.30/NA)			1230 (5471)	
GSX20-0601	2.25 (57)	6 (150)	0.1 (2.54)	367/578/NA (1632/2571/NA)	8.33 (211.67)	7.3/11.5/NA (0.82/1.30/NA)	1250 (5560)	0.00114 (0.000129)	2075 (9230)	8.0 (3.6)
GSX20-0602			0.2 (5.08)	183/289/385 (814/1286/1713)	16.67 (423.33)	7.3/11.5/15.3 (0.82/1.30/1.73)			1540 (6850)	
GSX20-0604			0.4 (10.16)	92/145/192 (409/645/854)	33.33 (846.67)	7.3/11.5/15.3 (0.82/1.30/1.73)			1230 (5471)	
GSX20-1001	2.25 (57)	10 (250)	0.1 (2.54)	367/578/NA (1632/2571/NA)	8.33 (211.67)	7.3/11.5/NA (0.82/1.30/NA)	1250 (5560)	0.00133 (0.000150)	2075 (9230)	9.5 (4.3)
GSX20-1002			0.2 (5.08)	183/289/385 (814/1286/1713)	16.67 (423.33)	7.3/11.5/15.3 (0.82/1.30/1.73)			1540 (6850)	
GSX20-1004			0.4 (10.16)	92/145/192 (409/645/854)	33.33 (846.67)	7.3/11.5/15.3 (0.82/1.30/1.73)			1230 (5471)	
GSX20-1201	2.25 (57)	12 (300)	0.1 (2.54)	367/578/NA (1632/2571/NA)	8.33 (211.67)	7.3/11.5/NA (0.82/1.30/NA)	1250 (5560)	0.00143 (0.000162)	2075 (9230)	11.0 (4.9)
GSX20-1202			0.2 (5.08)	183/289/385 (814/1286/1713)	16.67 (423.33)	7.3/11.5/15.3 (0.82/1.30/1.73)			1540 (6850)	
GSX20-1204			0.4 (10.16)	92/145/192 (409/645/854)	33.33 (846.67)	7.3/11.5/15.3 (0.82/1.30/1.73)			1230 (5471)	
GSX30-0301	3.125 (79)	3 (75)	0.1 (2.54)	829/1347/NA (3688/5992/NA)	5 (127)	16.5/26.8/NA (1.86/3.03/NA)	2700 (12010)	0.00319 (0.000360)	5516 (24536)	9.5 (4.3)
GSX30-0302			0.2 (5.08)	415/674/NA (1846/2998/NA)	10 (254)	16.5/26.8/NA (1.86/3.03/NA)			5800 (25798)	
GSX30-0305			0.5 (12.7)	166/269/NA (738/1197/NA)	25 (635)	16.5/26.8/NA (1.86/3.03/NA)			4900 (21795)	
GSX30-0601	3.125 (79)	5.9 (150)	0.1 (2.54)	829/1347/NA (3688/5992/NA)	5 (127)	16.5/26.8/NA (1.86/3.03/NA)	2700 (12010)	0.00361 (0.000408)	5516 (24536)	11.5 (5.2)
GSX30-0602			0.2 (5.08)	415/674/905 (1846/2998/4026)	10 (254)	16.5/26.8/36 (1.86/3.03/4.07)			5800 (25798)	
GSX30-0605			0.5 (12.7)	166/269/362 (738/1197/1610)	25 (635)	16.5/26.8/36 (1.86/3.03/4.07)			4900 (21795)	
GSX30-1001	3.125 (79)	10 (250)	0.1 (2.54)	829/1347/NA (3688/5992/NA)	5 (127)	16.5/26.8/NA (1.86/3.03/NA)	2700 (12010)	0.00416 (0.00047)	5516 (24536)	19 (8.6)
GSX30-1002			0.2 (5.08)	415/674/905 (1846/2998/4026)	10 (254)	16.5/26.8/36 (1.86/3.03/4.07)			5800 (25798)	
GSX30-1005			0.5 (12.7)	166/269/362 (738/1197/1610)	25 (635)	16.5/26.8/36 (1.86/3.03/4.07)			4900 (21795)	
GSX30-1201	3.125 (79)	12 (305)	0.1 (2.54)	829/1347/NA (3688/5992/NA)	5 (127)	16.5/26.8/NA (1.86/3.03/NA)	2700 (12010)	0.00443 (0.000501)	5516 (24536)	20.5 (9.3)
GSX30-1202			0.2 (5.08)	415/674/905 (1846/2998/4026)	10 (254)	16.5/26.8/36 (1.86/3.03/4.07)			5800 (25798)	
GSX30-1205			0.5 (12.7)	166/269/362 (738/1197/1610)	25 (635)	16.5/26.8/36 (1.86/3.03/4.07)			4900 (21795)	
GSX30-1401	3.125 (79)	14 (355)	0.1 (2.54)	829/1347/NA (3688/5992/NA)	5 (127)	16.5/26.8/NA (1.86/3.03/NA)	2700 (12010)	0.00473 (0.000534)	5516 (24536)	20.5 (9.3)
GSX30-1402			0.2 (5.08)	415/674/905 (1846/2998/4026)	10 (254)	16.5/26.8/36 (1.86/3.03/4.07)			5800 (25798)	
GSX30-1405			0.5 (12.7)	166/269/362 (738/1197/1610)	25 (635)	16.5/26.8/36 (1.86/3.03/4.07)			4900 (21795)	
GSX30-1801	3.125 (79)	18 (457)	0.1 (2.54)	829/1347/NA (3688/5992/NA)	5 (127)	16.5/26.8/36 (1.86/3.03/4.07)	2700 (12010)	0.00533 (0.000602)	5516 (24536)	25 (11.3)
GSX30-1802			0.2 (5.08)	415/674/905 (1846/2998/4026)	10 (254)	16.5/26.8/36 (1.86/3.03/4.07)			5800 (25798)	
GSX30-1805			0.5 (12.7)	166/269/362 (738/1197/1610)	25 (635)	16.5/26.8/36 (1.86/3.03/4.07)			4900 (21795)	

* Please note that stroke mm are nominal dimensions. **Inertia +/- 5%
See page 13 for definition of terms.

Specifications subject to change without notice.

GSX40 Performance Specifications

Model No.	Frame Size in (mm)	Stroke (nominal)* in (mm)	Screw Lead in (mm)	Continuous Force Rating lb (N) 1/2/3 stack	Max Velocity in/sec (mm/sec)	Continuous Motor Torque lb-in (N-m)	Maximum Static Load lb (N)	Armature Inertia** lb-in-s ² (Kg-m ²)	Dynamic Load Rating lb (N)	Weight (approx.) lb (kg)
GSX40-0601	3.9 (99)	6 (150)	0.1 (2.54)	2393/3966/NA (10645/17642/NA)	5 (127)	47.6/78.9/NA (5.38/8.91/NA)	5400 (24020)	0.0152 (0.001717)	7900 (35141)	20 (9.1)
GSX40-0602			0.2 (5.08)	1196/1983/NA (5320/8821/NA)	10 (254)				8300 (36920)	
GSX40-0605			0.5 (12.7)	479/793/NA (2131/3527/NA)	25 (635)				7030 (31271)	
GSX40-0608			0.75 (19.05)	319/529/NA (1419/2353/NA)	37.5 (953)				6335 (28179)	
GSX40-0801	3.9 (99)	8 (200)	0.1 (2.54)	2393/3966/NA (10645/17642/NA)	5 (127)	47.6/78.9/107.1 (5.38/8.91/12.1)	5400 (24020)	0.0163 (0.001842)	7900 (35141)	24 (10.9)
GSX40-0802			0.2 (5.08)	1196/1983/2692 (5320/8821/11975)	10 (254)				8300 (36920)	
GSX40-0805			0.5 (12.7)	479/793/1077 (2131/3527/4791)	25 (635)				7030 (31271)	
GSX40-0808			0.75 (19.05)	319/529/718 (1419/2353/3194)	37.5 (953)				6335 (28179)	
GSX40-1001	3.9 (99)	10 (250)	0.1 (2.54)	2393/3966/NA (10645/17642/NA)	5 (127)	47.6/78.9/107.1 (5.38/8.91/12.1)	5400 (24020)	0.0175 (0.001977)	7900 (35141)	28 (12.7)
GSX40-1002			0.2 (5.08)	1196/1983/2692 (5320/8821/11975)	10 (254)				8300 (36920)	
GSX40-1005			0.5 (12.7)	479/793/1077 (2131/3527/4791)	25 (635)				7030 (31271)	
GSX40-1008			0.75 (19.05)	319/529/718 (1419/2353/3194)	37.5 (953)				6335 (28179)	
GSX40-1201	3.9 (99)	12 (305)	0.1 (2.54)	2393/3966/NA (10645/17642/NA)	5 (127)	47.6/78.9/107.1 (5.38/8.91/12.1)	5400 (24020)	0.0186 (0.002102)	7900 (35141)	32 (14.5)
GSX40-1202			0.2 (5.08)	1196/1983/2692 (5320/8821/11975)	10 (254)				8300 (36920)	
GSX40-1205			0.5 (12.7)	479/793/1077 (2131/3527/4791)	25 (635)				7030 (31271)	
GSX40-1208			0.75 (19.05)	319/529/718 (1419/2353/3194)	37.5 (953)				6335 (28179)	
GSX40-1801	3.9 (99)	18 (457)	0.1 (2.54)	2393/3966/NA (10645/17642/NA)	5 (127)	47.6/78.9/107.1 (5.38/8.91/12.1)	5400 (24020)	0.022 (0.002486)	7900 (35141)	44 (20)
GSX40-1802			0.2 (5.08)	1196/1983/2692 (5320/8821/11975)	10 (254)				8300 (36920)	
GSX40-1805			0.5 (12.7)	479/793/1077 (2131/3527/4791)	25 (635)				7030 (31271)	

* Please note that stroke mm are nominal dimensions. **Inertia +/- 5%
See page 13 for definition of terms.

Specifications subject to change without notice.

GSX50 & GSX60 Performance Specifications

Model No.	Frame Size in (mm)	Stroke (nominal)* in (mm)	Screw Lead in (mm)	Continuous Force Rating lb (N) 1/2/3 stack	Max Velocity in/sec (mm/sec)	Continuous Motor Torque lb-in (N-m)	Maximum Static Load lb (N)	Armature Inertia** lb-in-s ² (Kg-m ²)	Dynamic Load Rating lb (N)	Weight (approx.) lb (kg)
GSX50-0601	5.5 (140)	6 (150)	0.1 (2.54)	5127/8544/NA (22806/38006/NA)	4 (101.6)	102/170/NA (11.5/19.2/NA)	13200 (58717)	0.03241 (0.003662)	15693 (69806)	54 (24)
GSX50-0602			0.2 (5.08)	2564/4272/NA (11405/19003/NA)	8 (203)				13197 (58703)	
GSX50-0605			0.5 (12.7)	1026/1709/NA (4564/7602/NA)	20 (508)				11656 (51848)	
GSX50-0610			1.0 (25.4)	513/855/NA (2282/3803/NA)	40 (1016)				6363 (28304)	
GSX50-1001	5.5 (140)	10 (250)	0.1 (2.54)	5127/8544/NA (22806/38006/NA)	4 (101.6)	102/170/NA (11.5/19.2/NA)	13200 (58717)	0.03725 (0.004209)	15693 (69806)	62 (28)
GSX50-1002			0.2 (5.08)	2564/4272/5655 (11405/19003/25155)	8 (203)				13197 (58703)	
GSX50-1005			0.5 (12.7)	1026/1709/2261 (4564/7602/10057)	20 (508)				11656 (51848)	
GSX50-1010			1.0 (25.4)	513/855/1131 (2282/3803/5031)	40 (1016)				6363 (28304)	
GSX50-1402	5.5 (140)	14 (355)	0.2 (5.08)	2564/4272/5655 (11405/19003/25155)	8 (203)	102/170/226 (11.5/19.2/25.5)	13200 (58717)	0.04208 (0.004756)	13197 (58703)	70 (32)
GSX50-1405			0.5 (12.7)	1026/1709/2261 (4564/7602/10057)	20 (508)				11656 (51848)	
GSX60-0603	7.0 (178)	6 (150)	0.25 (6.35)	5098/NA/NA (22677/NA/NA)	10 (254)	241/NA/NA (27/NA/NA)	25000 (111200)	0.1736 (0.019614)	25300 (112540)	69 (31)
GSX60-0605			0.5 (12.7)	2549/NA/NA (11339/NA/NA)	20 (508)				22800 (101420)	
GSX60-0610			1.0 (25.4)	1275/NA/NA (5671/NA/NA)	40 (1018)				21200 (94302)	
GSX60-1003	7.0 (178)	10 (250)	0.25 (6.35)	5098/8656/12389 (22677/38504/55109)	10 (254)	241/409/585 (27/46/66)	25000 (111200)	0.1943 (0.021953)	25300 (112540)	101 (46)
GSX60-1005			0.5 (12.7)	2549/4328/6195 (11339/19252/27557)	20 (508)				22800 (101420)	
GSX60-1010			1.0 (25.4)	1275/2164/3097 (5671/9626/13776)	40 (1018)				21200 (94302)	

* Please note that stroke mm are nominal dimensions. **Inertia +/- 5%

Specifications subject to change without notice.

DEFINITION OF TERMS:

Force Rating: The linear force produced by the actuator at continuous motor torque.

Max Velocity: The linear velocity that the actuator will achieve at rated motor rpm.

Continuous Motor Torque: Torque produced by the motor at rated continuous current.

Maximum Static Load: The mechanical load limit of the actuator if re-circulated oil or other cooling method is used to allow higher than rated torque from the motor.

Armature Inertia: The rotary inertia of the armature of the GSX Series actuators. For calculation purposes, this value includes the screw inertia in a GSX actuator.

Dynamic Load Rating: A design constant used in calculating the estimated travel life of the roller screw. The cubic mean load is the load at which the device will perform one million revolutions.

GSX offers 1, 2, or 3 stack stators providing 3 torque force levels.

GSX20 Mechanical and Electrical Specifications

Nominal Backlash	in (mm)	0.004 (.10)											
Maximum Backlash (pre-loaded)	in (mm)	0.0											
Lead Accuracy	in/ft (mm/300 mm)	0.001 (.025)											
Maximum Radial Load	lb (N)	20 (90)											
Environmental Rating: Standard		IP65											
Motor Stator		118	138	158	168	218	238	258	268	318*	338*	358*	368*
RMS SINUSOIDAL COMMUTATION													
Continuous Motor Torque	lbf-in (Nm)	7.6 (0.86)	7.3 (0.83)	7.0 (0.79)	7.0 (0.79)	11.9 (1.35)	11.5 (1.30)	11.2 (1.27)	11.3 (1.28)	15.3 (1.73)	15.3 (1.73)	14.8 (1.67)	15.0 (1.69)
Torque Constant (Kt) (+/- 10% @ 25°C)	lbf-in/A (Nm/A)	2.5 (0.28)	5.2 (0.59)	8.3 (0.94)	9.5 (1.07)	2.5 (0.28)	5.2 (0.59)	8.9 (1.00)	10.2 (1.15)	2.3 (0.26)	5.3 (0.60)	8.8 (0.99)	10.2 (1.15)
Continuous Current Rating:	Greased (IG) A	3.4	1.6	0.9	0.8	5.4	2.5	1.4	1.2	7.3	3.2	1.9	1.6
	Oiled (IL) A	6.9	3.1	1.9	1.6	10.8	4.9	2.8	2.5	14.6	6.5	3.8	3.3
Peak Current Rating	Amps	6.9	3.1	1.9	1.6	10.8	4.9	2.8	2.5	14.6	6.5	3.8	3.3
TRAPEZOIDAL COMMUTATION													
Continuous Motor Torque	lbf-in (Nm)	7.3 (0.82)	7.0 (0.79)	6.7 (0.76)	6.7 (0.76)	11.4 (1.29)	11.0 (1.24)	10.7 (1.21)	10.8 (1.22)	14.7 (1.66)	14.6 (1.65)	14.1 (1.60)	14.3 (1.61)
Torque Constant (Kt) (+/- 10% @ 25°C)	lbf-in/A (Nm/A)	1.9 (0.22)	4.1 (0.46)	6.5 (0.73)	7.4 (0.84)	1.9 (0.22)	4.1 (0.46)	6.9 (0.78)	7.9 (0.89)	1.8 (0.21)	4.1 (0.46)	6.9 (0.77)	7.9 (0.89)
Continuous Current Rating	Greased (IG) A	4.2	1.9	1.1	1.0	6.6	3.0	1.7	1.5	9.0	4.0	2.3	2.0
	Oiled (IL) A	8.4	3.9	2.3	2.0	13.2	6.0	3.5	3.0	17.9	8.0	4.6	4.0
Peak Current Rating	Amps	8.4	3.9	2.3	2.0	13.2	6.0	3.5	3.0	17.9	8.0	4.6	4.0
MOTOR STATOR DATA													
Voltage Constant (Ke)	Vrms/Krpm	16.9	35.6	56.9	64.9	16.9	35.6	60.5	69.4	16.0	36.0	60.0	69.4
	Vpk/Krpm	23.9	50.3	80.5	91.8	23.9	50.3	85.5	98.1	22.6	50.9	84.9	98.1
Pole Configuration		8	8	8	8	8	8	8	8	8	8	8	8
Resistance (L-L)(+/- 5% @ 25°C)	Ohms	2.6	12.5	35.2	45.8	1.1	5.3	16.0	20.7	0.62	3.1	9.4	12.2
Inductance (L-L)(+/- 15%)	mH	5.1	22.8	58.3	75.8	2.5	11.0	31.7	41.7	1.5	7.4	20.5	27.4
Brake Inertia	lbf-in-sec ² (Kg-cm ²)	0.00012 (0.135)											
Brake Current @ 24 VDC	A	0.33											
Brake Holding Torque	lbf-in (Nm)	19 (2.2)											
Brake Engage/Disengage Time	ms	14/28											
Mechanical Time Constant (tm), ms	min	6.0	6.5	7.1	7.1	2.5	2.7	2.9	2.8	1.6	1.6	1.7	1.7
	max	8.5	9.2	10.1	10.1	3.6	3.9	4.0	4.0	2.2	2.2	2.4	2.4
Electrical Time Constant (te)	ms	2.0	1.8	1.7	1.7	2.2	2.1	2.0	2.0	2.4	2.4	2.2	2.2
Damping Constant	lbf-in/krpm (N-m/krpm)	0.55 (0.06)				0.55 (0.06)				0.55 (0.06)			
Friction Torque	lbf-in (Nm)	1.00 (0.11)				1.00 (0.11)				1.00 (0.11)			
Additional Friction Torque for Preloaded Screw	lbf-in (Nm)	1.25 (0.14)				1.25 (0.14)				1.25 (0.14)			
Bus Voltage	Vrms	115	230	400	460	115	230	400	460	115	230	400	460
Speed @ Bus Voltage	rpm	5000											
Insulation Class		180 (H)											

All ratings at 25 degrees Celsius

For amplifiers using peak sinusoidal ratings, multiply RMS sinusoidal Kt by .707 and current by 1.414.

*Refer to performance specifications on page 11 for availability of 3 stack stator by stroke/lead combination.

Test data derived using NEMA recommended aluminum heatsink 10" x 10" x 1/4"

Specifications subject to change without notice.

GSX30 Mechanical and Electrical Specifications

Nominal Backlash	in (mm)	0.004 (.10)											
Maximum Backlash (pre-loaded)	in (mm)	0.0											
Lead Accuracy	in/ft (mm/300 mm)	0.001 (.025)											
Maximum Radial Load	lb (N)	30 (134)											
Environmental Rating: Standard		IP65											
Motor Stator		118	138	158	168	218	238	258	268	318*	338*	358*	368*
RMS SINUSOIDAL COMMUTATION													
Continuous Motor Torque	lbf-in (Nm)	16.6 (1.87)	16.5 (1.86)	15.7 (1.77)	15.7 (1.78)	26.8 (3.03)	26.8 (3.03)	26.7 (3.02)	26.7 (3.01)	38.7 (3.01)	38.3 (4.33)	36.3 (4.10)	36.3 (4.10)
Torque Constant (Kt) (+/- 10% @ 25°C)	lbf-in/A (Nm/A)	4.4 (0.49)	8.7 (0.99)	15.5 (1.75)	17.5 (1.98)	4.4 (0.49)	8.7 (0.99)	15.5 (1.75)	17.5 (1.98)	4.4 (0.50)	8.7 (0.98)	15.7 (1.77)	17.6 (1.98)
Continuous Current Rating:	Greased (IG) A	4.2	2.1	1.1	1.0	6.9	3.4	1.9	1.7	9.7	4.9	2.6	2.3
	Oiled (IL) A	8.5	4.2	2.3	2.0	13.7	6.8	3.8	3.4	19.5	9.9	5.2	4.6
Peak Current Rating	Amps	8.5	4.2	2.3	2.0	13.7	6.8	3.8	3.4	19.5	9.9	5.2	4.6
TRAPEZOIDAL COMMUTATION													
Continuous Motor Torque	lbf-in (Nm)	15.9 (1.79)	15.8 (1.79)	14.9 (1.68)	15.0 (1.69)	25.6 (2.89)	25.6 (2.89)	25.5 (2.88)	25.5 (2.88)	37.0 (4.18)	36.6 (4.14)	34.6 (3.91)	34.7 (3.92)
Torque Constant (Kt) (+/- 10% @ 25°C)	lbf-in/A (Nm/A)	3.4 (0.39)	6.8 (0.77)	12.1 (1.37)	13.6 (1.54)	3.4 (0.39)	6.8 (0.77)	12.1 (1.37)	13.6 (1.54)	3.5 (0.39)	6.8 (0.76)	12.2 (1.38)	13.7 (1.55)
Continuous Current Rating:	Greased (IG) A	5.2	2.6	1.4	1.2	8.4	4.2	2.4	2.1	11.9	6.0	3.2	2.8
	Oiled (IL) A	10.4	5.2	2.8	2.5	16.8	8.4	4.7	4.2	23.9	12.1	6.3	5.7
Peak Current Rating	Amps	10.4	5.2	2.8	2.5	16.8	8.4	4.7	4.2	23.9	12.1	6.3	5.7
MOTOR STATOR DATA													
Voltage Constant (Ke)	Vrms/Krpm	29.9	59.7	106.0	119.5	29.9	59.7	106.0	119.5	30.3	59.2	106.9	119.9
	(+/- 10% @ 25°C) Vpk/Krpm	42.2	84.5	149.9	169.0	42.2	84.5	149.9	168.9	42.9	83.8	151.2	169.6
Pole Configuration		8	8	8	8	8	8	8	8	8	8	8	8
Resistance (L-L)(+/- 5% @ 25°C)	Ohms	2.8	11.2	39.5	49.6	1.1	4.5	14.1	18.0	0.65	2.6	9.3	11.6
Inductance (L-L)(+/- 15%)	mH	7.7	30.7	96.8	123.0	3.7	14.7	46.2	58.7	2.5	9.5	30.9	38.8
Brake Inertia	lbf-in-sec ² (Kg-cm ²)	0.00033 (0.38)											
Brake Current @ 24VDC	A	0.5											
Brake Holding Torque	lbf-in (Nm)	70 (8)											
Brake Engage/Disengage Time	ms	19/29											
Mechanical Time Constant (tm), ms	min	6.5	6.5	7.3	7.2	2.6	2.6	2.6	2.6	1.5	1.5	1.7	1.7
	max	10.8	10.9	12.2	12.0	4.3	4.3	4.4	4.4	2.5	2.5	2.8	2.8
Electrical Time Constant (te)	ms	2.8	2.7	2.5	2.5	3.3	3.3	3.3	3.3	3.8	3.7	3.3	3.3
Damping Constant	lbf-in/krpm (N-m/krpm)	1.23 (.14)				1.23 (.14)				1.23 (.14)			
Friction Torque	lbf-in (Nm)	2.00 (0.23)				2.00 (0.23)				2.00 (0.23)			
Additional Friction Torque for Preloaded Screw	lbf-in (Nm)	1.75 (0.20)				1.75 (0.20)				1.75 (0.20)			
Bus Voltage	Vrms	115	230	400	460	115	230	400	460	115	230	400	460
Speed @ Bus Voltage	rpm	3000											
Insulation Class		180 (H)											

All ratings at 25 degrees Celsius

For amplifiers using peak sinusoidal ratings, multiply RMS sinusoidal Kt by .707 and current by 1.414.

*Refer to performance specifications on page 11 for availability of 3 stack stator by stroke/lead combination.

Test data derived using NEMA recommended aluminum heatsink 10" x 10" x 3/8"

Specifications subject to change without notice.

GSX40 Mechanical and Electrical Specifications

Nominal Backlash	in (mm)	0.004 (.10)											
Maximum Backlash (pre-loaded)	in (mm)	0.0											
Lead Accuracy	in/ft (mm/300 mm)	0.001 (.025)											
Maximum Radial Load	lb (N)	40 (179)											
Environmental Rating: Standard		IP65											
Motor Stator		118	138	158	168	238	258	268	338*	358*	368*		
RMS SINUSOIDAL COMMUTATION													
Continuous Motor Torque	lbf-in (Nm)	47.6 (5.38)	47.6 (5.37)	44.7 (5.05)	45.5 (5.14)	78.8 (8.91)	78.8 (8.91)	79.7 (9.00)	107.1 (12.10)	105.5 (11.92)	107.1 (12.10)		
Torque Constant (Kt) (+/- 10% @ 25°C)	lbf-in/A (Nm/A)	4.1 (0.46)	8.2 (0.93)	14.6 (1.65)	16.8 (1.90)	8.2 (0.93)	14.6 (1.65)	16.8 (1.90)	8.4 (0.95)	14.6 (1.65)	16.8 (1.90)		
Continuous Current Rating:	Greased (IG) A	12.9	6.5	3.4	3.0	10.7	6.0	5.3	14.2	8.1	7.1		
	Oiled (IL) A	25.9	12.9	6.9	6.0	21.4	12.1	10.6	28.5	16.2	14.2		
Peak Current Rating	Amps	25.9	12.9	6.9	6.0	21.4	12.1	10.6	28.5	16.2	14.2		
TRAPEZOIDAL COMMUTATION													
Continuous Motor Torque	lbf-in (Nm)	45.5 (5.14)	45.4 (5.13)	42.7 (4.83)	43.5 (4.91)	75.3 (8.51)	75.3 (8.50)	76.1 (8.60)	102.3 (11.56)	100.7 (11.38)	102.3 (11.56)		
Torque Constant (Kt) (+/- 10% @ 25°C)	lbf-in/A (Nm/A)	3.2 (0.36)	6.4 (0.72)	11.4 (1.28)	13.1 (1.48)	6.4 (0.72)	11.4 (1.28)	13.1 (1.48)	6.6 (0.74)	11.4 (1.28)	13.1 (1.48)		
Continuous Current Rating:	Greased (IG) A	15.9	7.9	4.2	3.7	13.1	7.4	6.5	17.4	9.9	8.7		
	Oiled (IL) A	31.7	15.8	8.4	7.4	26.3	14.8	13.0	34.9	19.8	17.4		
Peak Current Rating	Amps	31.7	15.8	8.4	7.4	26.3	14.8	13.0	34.9	19.8	17.4		
MOTOR STATOR DATA													
Voltage Constant (Ke)	Vrms/Krpm	28.1	56.1	99.5	114.8	56.1	99.5	114.8	57.4	99.5	114.8		
	Vpk/Krpm	39.7	79.4	140.7	162.4	79.4	140.7	162.4	81.2	140.7	162.4		
Pole Configuration		8	8	8	8	8	8	8	8	8			
Resistance (L-L) (+/- 5% @ 25°C)	Ohms	0.4	1.7	6.0	7.8	0.7	2.26	3.0	0.5	1.52	1.9		
Inductance (L-L) (+/- 15%)	mH	3.0	11.9	37.5	49.9	5.8	18.2	24.2	4.0	12.0	16.0		
Brake Inertia	lbf-in-sec ² (Kg-cm ²)	0.00096 (1.08)											
Brake Current @ 24 VDC	A	0.67											
Brake Holding Torque	lbf-in (Nm)	97 (11)											
Brake Engage/Disengage Time	ms	20/29											
Mechanical Time Constant (tm), ms	min	5.3	5.3	6.0	5.8	2.3	2.3	2.2	1.5	1.5	1.5		
	max	7.7	7.7	8.7	8.4	3.3	3.3	3.2	2.1	2.2	2.1		
Electrical Time Constant (te)	ms	7.0	7.0	6.2	6.4	8.0	8.0	8.2	8.2	7.9	8.2		
Damping Constant	lbf-in/krpm (N-m/krpm)	3.25 (0.37)				3.25 (0.37)				3.25 (0.37)			
Friction Torque	lbf-in (Nm)	4.5 (0.51)				4.5 (0.51)				4.5 (0.51)			
Additional Friction Torque for Preloaded Screw	lbf-in (Nm)	3.00 (0.34)				3.00 (0.34)				3.00 (0.34)			
Bus Voltage	Vrms	115	230	400	460	230	400	460	230	400	460		
Speed @ Bus Voltage	rpm	3000											
Insulation Class		180 (H)											

All ratings at 25 degrees Celsius

For amplifiers using peak sinusoidal ratings, multiply RMS sinusoidal Kt by .707 and current by 1.414.

*Refer to performance specifications on page 12 for availability of 3 stack stator by stroke/lead combination.

Test data derived using NEMA recommended aluminum heatsink 12" x 12" x 1/2"

Specifications subject to change without notice.

GSX50 Mechanical and Electrical Specifications

Nominal Backlash	in (mm)	0.004 (.10)							
Maximum Backlash (pre-loaded)	in (mm)	0.0							
Lead Accuracy	in/ft (mm/300 mm)	0.001 (.025)							
Maximum Radial Load	lb (N)	75 (337)							
Environmental Rating: Standard		IP65							
Motor Stator		138	158	168	238	258	268	358*	368*
RMS SINUSOIDAL COMMUTATION									
Continuous Motor Torque	lbf-in (Nm)	106.9 (12.07)	104.4 (11.80)	106.2 (12.00)	179.2 (20.25)	178.2 (20.13)	177.2 (20.02)	236.4 (26.71)	237.5 (26.83)
Torque Constant (Kt) (+/- 10% @ 25 °C)	lbf-in/A (Nm/A)	11.8 (1.33)	20.1 (2.28)	23.5 (2.66)	11.8 (1.33)	20.1 (2.28)	23.5 (2.66)	20.1 (2.28)	23.9 (2.70)
Continuous Current Rating:	Greased (IG) A	10.2	5.8	5.0	17.0	9.9	8.4	13.1	11.1
	Oiled (IL) A	20.3	11.6	10.1	34.1	19.8	16.8	26.2	22.2
Peak Current Rating	Amps	20.3	11.6	10.1	34.1	19.8	16.8	26.2	22.2
TRAPEZOIDAL COMMUTATION									
Continuous Motor Torque	lbf-in (Nm)	102.0 (11.53)	99.7 (11.26)	101.5 (11.46)	171.1 (19.34)	170.1 (19.22)	169.2 (19.12)	225.8 (25.51)	226.8 (25.62)
Torque Constant (Kt) (+/- 10% @ 25 °C)	lbf-in/A (Nm/A)	9.2 (1.04)	15.7 (1.77)	18.3 (2.07)	9.2 (1.04)	15.7 (1.77)	18.3 (2.07)	15.7 (1.77)	18.7 (2.11)
Continuous Current Rating:	Greased (IG) A	12.4	7.1	6.2	20.9	12.1	10.3	16.1	13.6
	Oiled (IL) A	24.9	14.2	12.4	41.7	24.2	20.6	32.1	27.2
Peak Current Rating	Amps	24.9	14.2	12.4	41.7	24.2	20.6	32.1	27.2
MOTOR STATOR DATA									
Voltage Constant (Ke)	Vrms/Krpm	80.3	137.6	160.6	80.3	137.6	160.6	137.6	163.4
(+/- 10% @ 25 °C)	Vpk/Krpm	113.5	194.6	227.1	113.5	194.6	227.1	194.6	231.1
Pole Configuration		8	8	8	8	8	8	8	
Resistance (L-L)(+/- 5% @ 25 °C)	Ohms	1.00	3.09	4.06	0.37	1.11	1.52	0.66	0.92
Inductance (L-L)(+/- 15%)	mH	23.7	69.6	94.8	10.7	31.6	43.0	20.3	28.7
Brake Inertia	lbf-in-sec ² (Kg-cm ²)	0.0084 (9.5)							
Brake Current @ 24VDC	A	1							
Brake Holding Torque	lbf-in (Nm)	354 (40)							
Brake Engage/Disengage Time	ms	25/73							
Mechanical Time Constant (tm), ms	min	3.3	3.4	3.3	1.2	1.2	1.2	0.7	0.7
	max	4.7	5.0	4.8	1.8	1.8	1.8	1.1	1.0
Electrical Time Constant (te)	ms	23.6	22.6	23.4	28.9	28.5	28.2	31.0	31.2
Damping Constant	lbf-in/krpm (N-m/krpm)	7.00 (0.79)			7.00 (0.79)			7.00 (0.79)	
Friction Torque	lbf-in (Nm)	8.00 (0.90)			8.00 (0.90)			8.00 (0.90)	
Additional Friction Torque for Preloaded Screw	lbf-in (Nm)	6.00 (0.68)			6.00 (0.68)			6.00 (0.68)	
Bus Voltage	Vrms	230	400	460	230	400	460	400	460
Speed @ Bus Voltage	rpm	2400							
Insulation Class		180 (H)							

For amplifiers using peak sinusoidal ratings, multiply RMS sinusoidal Kt by .707 and current by 1.414. Test data derived using NEMA recommended aluminum heatsink 12" x 12" x 1/2"

Specifications subject to change without notice.

GSX60 Mechanical and Electrical Specifications

Nominal Backlash	in (mm)	0.004 (.10)							
Maximum Backlash (pre-loaded)	in (mm)	0.0							
Lead Accuracy	in/ft (mm/300 mm)	0.001 (.025)							
Maximum Radial Load	lb (N)	100 (445)							
Environmental Rating: Standard		IP65							
Motor Stator		138	158	168	238	258	268	358	368
RMS SINUSOIDAL COMMUTATION									
Continuous Motor Torque	lbf-in (Nm)	252.6 (28.53)	249.9 (28.23)	252.6 (28.53)	424.8 (47.79)	423.0 (47.79)	427.5 (48.30)	604.2 (68.26)	615.0 (69.49)
Torque Constant (Kt) (+/- 10% @ 25°C)	lbf-in/A (Nm/A)	12.6 (1.42)	21.8 (2.46)	25.2 (2.84)	12.6 (1.42)	21.8 (2.46)	25.2 (2.84)	21.4 (2.42)	25.2 (2.84)
Continuous Current Rating:	Greased (IG) A	22.4	12.8	11.2	37.7	21.7	19.0	31.6	27.3
	Oiled (IL) A	44.9	25.6	22.4	75.5	43.4	38.0	63.1	54.6
Peak Current Rating	Amps	44.9	25.6	22.4	75.5	43.4	38.0	63.1	54.6
TRAPEZOIDAL COMMUTATION									
Continuous Motor Torque	lbf-in (Nm)	241.2 (27.25)	238.6 (26.96)	241.2 (27.25)	405.7 (45.83)	404.0 (45.65)	408.3 (46.13)	577.0 (65.19)	587.3 (66.35)
Torque Constant (Kt) (+/- 10% @ 25°C)	lbf-in/A (Nm/A)	9.8 (1.11)	17.0 (1.92)	19.6 (2.22)	9.8 (1.11)	17.0 (1.92)	19.6 (2.22)	16.7 (1.88)	19.6 (2.22)
Continuous Current Rating:	Greased (IG) A	27.5	15.7	13.7	46.2	26.5	23.3	38.7	33.4
	Oiled (IL) A	54.9	31.4	27.5	92.4	53.0	46.5	77.3	66.9
Peak Current Rating	Amps	54.9	31.4	27.5	92.4	53.0	46.5	77.3	66.9
MOTOR STATOR DATA									
Voltage Constant (Ke)	Vrms/Krpm	85.9	148.9	171.8	85.9	149.9	171.8	146.1	171.8
(+/- 10% @ 25°C)	Vpk/Krpm	121.5	210.6	243.0	121.5	210.6	243.0	206.6	243.0
Pole Configuration		8	8	8	8	8	8	8	8
Resistance (L-L) (+/- 5% @ 25°C)	Ohms	0.33	1.0	1.3	0.13	0.41	0.53	0.23	0.30
Inductance (L-L) (+/- 15%)	mH	8.3	24.8	33.0	3.9	11.8	15.8	7.5	10.3
Brake Inertia	lbf-in-sec ² (Kg-cm ²)	0.02815 (31.8)							
Brake Current @ 24 VDC	A	1.45							
Brake Holding Torque	lbf-in (Nm)	708 (80)							
Brake Engage/Disengage Time	ms	53/97							
Mechanical Time Constant (tm), ms	min	5.0	5.1	5.0	2.0	2.1	2.0	1.2	1.2
	max	5.6	5.7	5.6	2.3	2.3	2.3	1.3	1.3
Electrical Time Constant (te)	ms	25.4	24.6	25.1	29.4	29.1	29.8	33.0	34.2
Damping Constant	lbf-in/krpm (N-m/krpm)	28.0 (3.16)			28.0 (3.16)			28.0 (3.16)	
Friction Torque	lbf-in (Nm)	20.0 (2.26)			20.0 (2.26)			20.0 (2.26)	
Additional Friction Torque for Preloaded Screw	lbf-in (Nm)	6.00 (0.68)			6.00 (0.68)			6.00 (0.68)	
Bus Voltage	Vrms	230	400	460	230	400	460	400	460
Speed @ Bus Voltage	rpm	2400							
Insulation Class		180 (H)							

For amplifiers using peak sinusoidal ratings, multiply RMS sinusoidal Kt by .707 and current by 1.414.
 Test data derived using NEMA recommended aluminum heatsink 16" x 16" x 1"
 The GSX60-06 can only accommodate a single stack stator.

Specifications subject to change without notice.

GSX Series – System Configuration

GSX Series actuators include an integrated brushless servo motor. Exlar's unique design gives users a variety of the feedback configuration options so GSX units can be powered by almost any brushless motor amplifier on the market.

This flexibility means GSX actuators can be incorporated into today's highest performance single and multi-axis

motion control systems. In anything from food and beverage packaging, to multi-axis turning centers, to aircraft assembly, GSX Series units show incredible performance and durability.

The schematic below shows the typical connections for a single axis system with actuator and servo amplifier.

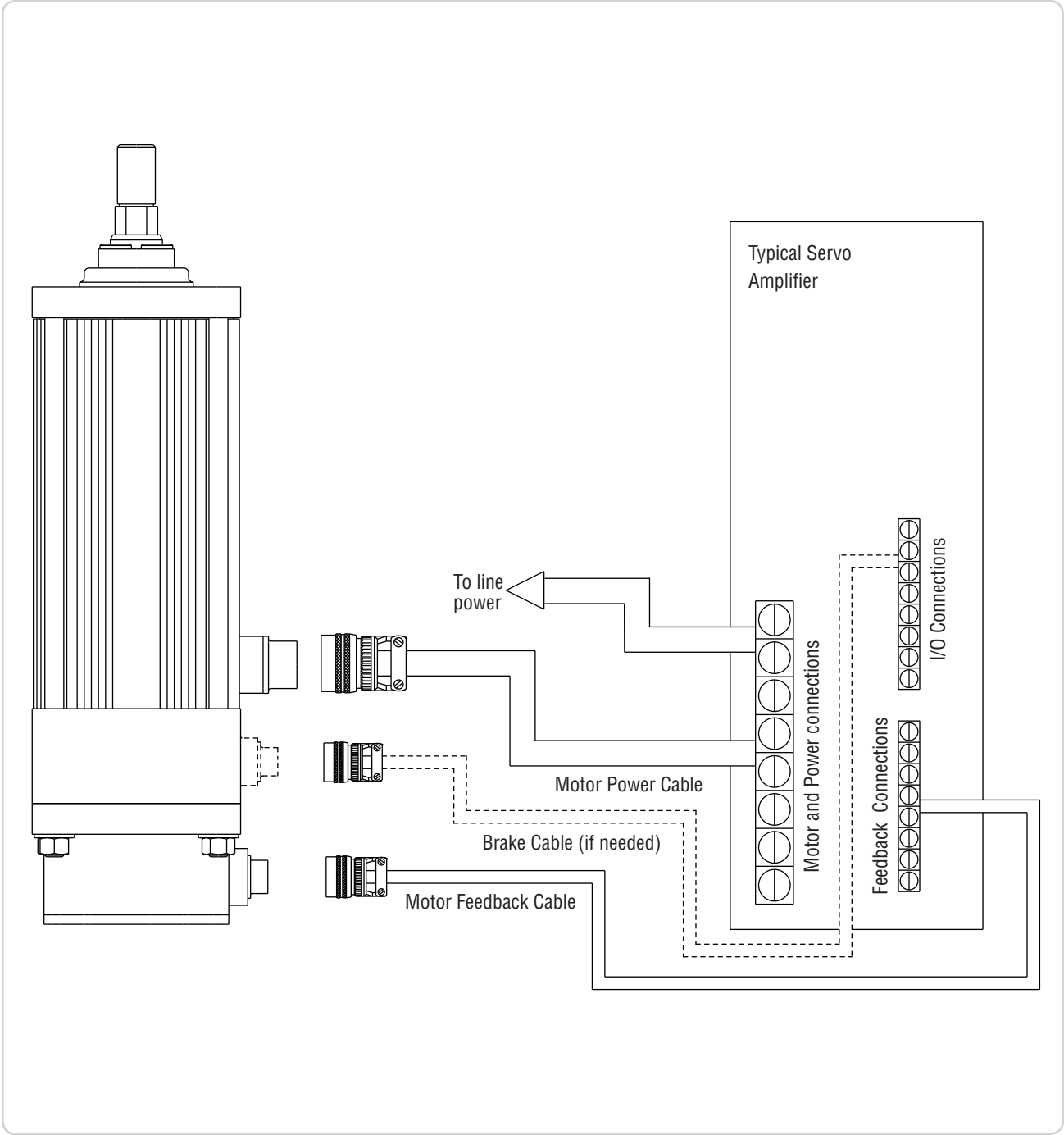

Drawings subject to change. Consult Exlar for certified drawings.

Oil Cooling and Lubrication

Consult Exlar if you plan to use oil cooling.

Exlar GSX series actuators can be lubricated with either grease or oil. All are shipped from the factory fully greased and are capable of functioning for many thousands of hours between re-greasings. Typically, greased lubrication is preferred for lower speed or intermittent duty applications. In these situations, you simply mount the actuator, connect the servo amplifier, and run.

However, many GSX Series actuators are deployed into applications involving high speed, high force, or both. To provide the cooling required when operating at these high power levels and/or to eliminate periodic re-greasing, all GSX units have another built-in feature. They are designed with an internal circulation path and the portings necessary for customers to convert from grease by connecting a recirculation oil system. This feature makes GSX units the only all-electric actuators on the market capable of true continuous-duty performance in moderate and high power applications when heat is an issue.

The conversion to externally supplied oil is simple. Identify which port will be highest when the actuator is mounted. That will become the oil supply side. For optimum cooling it is important that GSX actuators are mounted so the high-side port is at least above the unit's centerline, preferably in the top quarter region. This assures that the stator windings receive the oil's cooling benefits. Just connect your oil lines and you're done (See note 1 on page 21). Residual grease will be flushed out and filtered during initial operation.

A typical oil cooling system is shown below. Whenever application requirements are such that the RMS current requirement exceeds the continuous current rating of the GSX motor, oil cooling should be used to keep case temperatures below their 85 °C maximum specification. For very high speed applications, consult Exlar for oil routing recommendations.

Simple Oil System Schematic

As shown in the schematic to the right, a check valve or other method of pressure regulation should be used to maintain an internal actuator oil pressure of 5 psi.

Filtering of 25 microns or better should be used. Simple radiators or heat exchangers can be used to maintain oil temperature.

Locate oil system as close to actuator as possible. Use as large as possible oil line to minimize any possibility of flow restriction. The inlet port should be located higher than the outlet port.

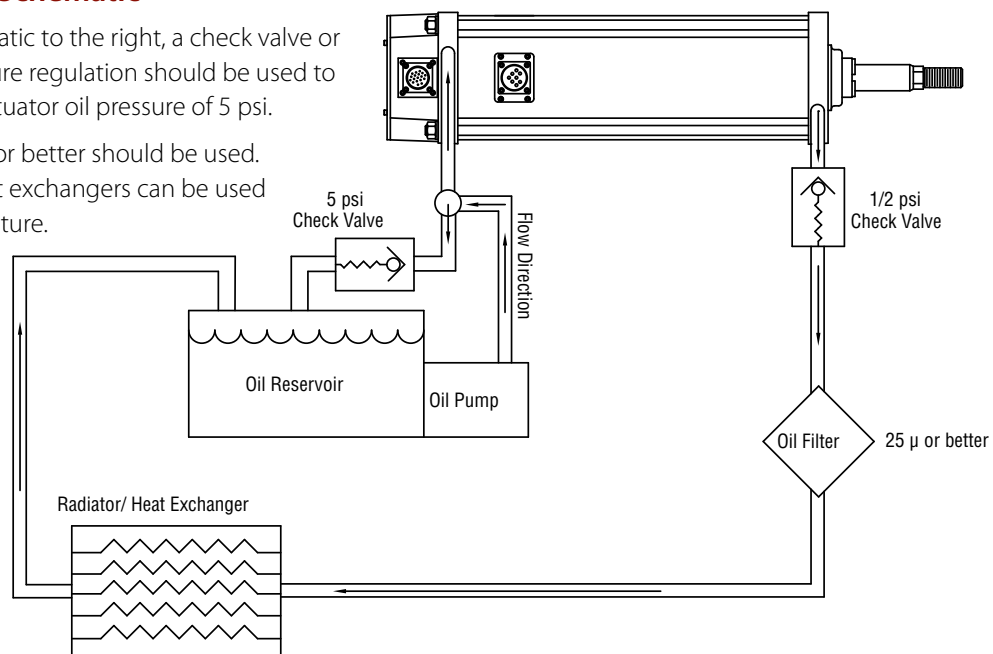

Exlar recommends the use of petroleum based gear oils with EP additive. An ISO 100 grade is suitable for most applications. Examples of this type of oil are: Mobil Mobilgear, Exxon Spartan EP, Shell Omala SG2 and Texaco Meropa. Oils meeting the FDA's food grade specifications are also available such as Mobil DTE FM 32.

Oil lubrication will typically require less frequent changing than grease. More importantly, oil is required in high power applications for cooling. In applications where the RMS current exceeds IG (see electrical specs on pages 14-18), oil lubrication is required in order to maintain the case

temperature below its maximum of 85°C (see note 2 bottom of page). When such oil lubrication is required, you can determine oil flow rates and case temperatures from this information:

Actuator Load Constants: $K_L = \left(\frac{^{\circ}\text{C} \times \text{Gal}}{\text{Hour}} \right)$

K_L GSX20	=	40
K_L GSX30	=	70
K_L GSX40	=	95
K_L GSX50	=	125
K_L GSX60	=	260

Application Load Factor: F_L

Where:

$$F_L = \left(\frac{I_{rms}}{I_G} \right)$$

I_{rms} = actual application current
 I_G = actuator current rating from specifications (see pages 14-18)

Use this relationship to determine oil flow requirements: W

$$W = K_L \frac{F_L}{\Delta T}$$

Where: $\Delta T = T_{CASE} - T_{OIL}$

Consider The Following Example:

A GSX30-238 requires 4 amps of RMS current to perform the required application. The incoming oil temperature is 45K°C, and we desire to maintain the actuator at it's maximum case temperature of 8°C.

$$F_L = (4/3.4)^2 = 1.38 \quad W = [(1.38 \times 70)/(85 - 45)] = 2.415 \text{ GAL / HOUR}$$

- IMPORTANT:** Some types of connectors or cabling MAY NOT be used with recirculated oil cooling because they are not constructed to prevent oil from passing through them. Some examples of these are any M23 type connectors (Intercontec/ Interconnectron style), any embedded leads, or 'M' connectors with -AB5, AB6, AB7, AB8, AB9, ABA and ABB feedback call outs. Please consult Exlar if you plan to use oil cooling to confirm that your selected connectorization is acceptable for use with oil cooling. New connector and feedback types are added regularly. The XL option should be selected in the product model mask and please indicate the intended use of oil cooling.
- GSX Series actuators can be ordered with features that allow them to achieve case temperatures of 150°C. Inquire with Exlar's application engineers or local representative for details.

Anti-rotation Option

The unique design of the GSX Series of linear actuators permits the extending rod to rotate. This simplifies actuator setup by allowing the user to rotate the rod and thread it in and out of the actuator for mechanical attachment or system testing.

However, this feature also requires that once setup and testing are completed, the rod be kept from rotating so proper linear motion will be maintained. In most applications the actuator's load is coupled to linear bearings, or some other support device. In these cases the load cannot rotate, and a separate anti-rotation system is not needed.

For applications in which the load is free to rotate, Exlar offers the anti-rotation systems shown right. Shorter GSX units use an anti-rotation arm on one side of the actuator. Longer strokes (defined above right) use arms on both sides.

Anti-rotation Option GSX/M20, GSX/M30, GSX/M40 and GSX60

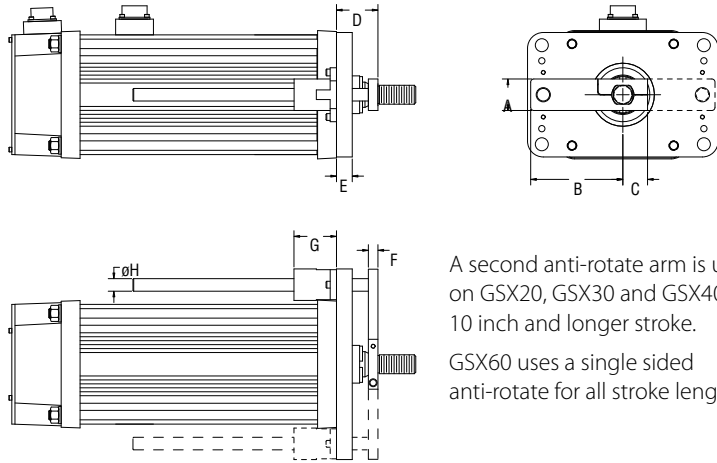

A second anti-rotate arm is used on GSX20, GSX30 and GSX40, 10 inch and longer stroke.

GSX60 uses a single sided anti-rotate for all stroke lengths.

Dims- in (mm)	GSX/M20	GSX/M30	GSX/M40	GSX60
A	0.60 (15.2)	0.79 (20.1)	1.25 (31.8)	1.75 (44.5)
B	1.81 (46.0)	2.54 (64.5)	3.78 (96.0)	5.79 (147)
C	0.54 (13.7)	0.71 (18.0)	0.98 (24.9)	1.55 (39.4)
D	1.00 (25.4)	1.30 (33.0)	1.64 (41.7)	1.94 (49.3)
E	0.44 (11.2)	0.44 (11.2)	0.63 (16.0)	0.75 (19.1)
F	0.28 (7.11)	0.32 (8.13)	0.38 (9.65)	0.50 (12.7)
G	0.31 (7.87)	1.69 (42.9)	1.69 (42.9)	2.81 (71.4)
øH	0.37 (9.40)	0.50 (12.7)	0.50 (12.7)	1.00 (25.4)

Anti-rotation Option GSX50

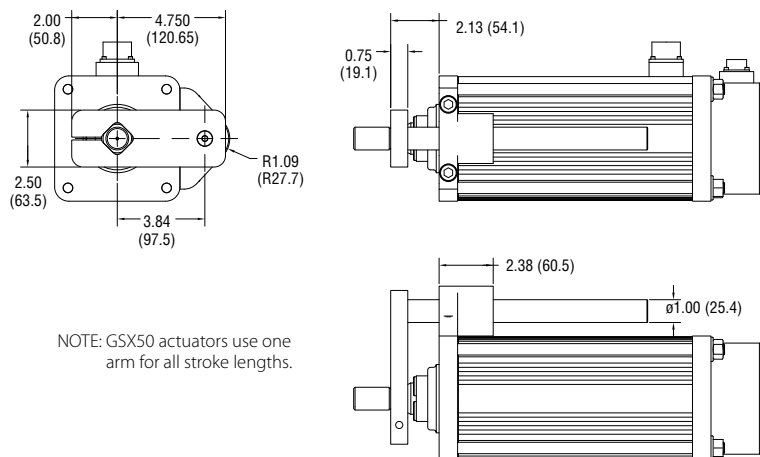

NOTE: GSX50 actuators use one arm for all stroke lengths.

GSX Series Travel Options

PF = Preloaded Follower

This option offers a true zero backlash follower for the GSX Series actuator. The dynamic load rating of zero backlash, preloaded screws is 63% of the dynamic load rating of the standard non-preloaded screws. The calculated travel life of a preloaded screw will be 25% of the calculated travel life of the same size and lead of a non-preloaded screw for the same application. Preloaded follower is not available with LT linear feedback option.

AR = External Anti-rotate Assembly

This option provides a rod and bushing to restrict the actuator rod from rotating when the load is not held by another method. Shorter actuators have single sided anti-rotation attachments. Longer lengths require attachments on both sides for proper operation.

RB = Rear Electric Brake

This option provides an internal holding brake for the GSX Series actuators. The brake is spring activated and electrically released.

XT = Special Travel Option Selections

The XT Option can be used to specify various special travel options on the GSX Series of Linear Actuators. Because this option can be used to specify many things, it is important that an order including the -XT option spell out in detail, the exact options being selected by the including of the -XT in the model number.

It is recommended that prior to ordering an actuator including the -XT specifier that a quote be obtained through Exlar's special products application engineers for the desired options, and that quote be referenced on, or included with any order placed.

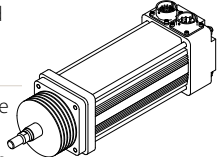
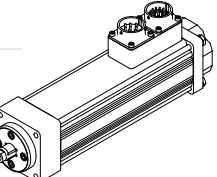
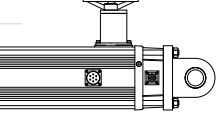
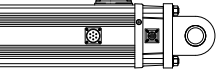
	Descriptions	
Protective Bellows	This option provides an accordion style protective bellows to protect the main actuator rod from damage due to abrasives or other contaminants in the environment in which the actuator must survive. The standard material of this bellows is S2 Neoprene Coated Nylon, Sewn Construction. This standard bellows is rated for environmental temperatures of -40 to 250 degrees F. Longer strokes may require the main rod of the actuator to be extended beyond standard length. Not available with extended tie rod mounting option. Consult Exlar applications engineers for details.	
High Temp Protective Bellows	This option provides an accordion style protective bellows to protect the main actuator rod from damage due to abrasives or other contaminants in the environment in which the actuator must survive. The high temperature material of this bellows is D1 Teflon Coated Fiberglass, Sewn Construction. This standard bellows is rated for environmental temperatures of -67 to 500 degrees F. Longer strokes may require the main rod of the actuator to be extended beyond standard length. Not available with extended tie rod mounting option. Consult Exlar applications engineers for details.	
Splined Main Rod	This option provides a main rod manufactured of ball spline shafting, and the front seal and bushing assembly replaced with a ball spline nut to provide the anti-rotate function without using an external mechanism. Rod diameters are the closest metric equivalents to standard Exlar rod sizes. This option is NOT sealed in any way. This option is not suitable for any environment in which contaminants come in contact with the actuator, and may enter the actuator. <i>Note: due to the reduced diameter of the splined main rod on the GSX50, the standard "A" male metric rod end is not available. An "X" should be used in the rod end location of the model mask. If not otherwise specified by the customer, an M24X2 male rod end will be used.</i>	
Manual Drive Handwheel	This option provides for a manual drive handwheel on the side of the actuator. The handwheel has a engagement/disengagement lever which allows for disengagement of the handwheel during operation. This engagement/disengagement lever is not tied to the operation of the motor and requires that the user guarantee its disengagement before operating the motor. Not available on GSX20.	

L1, L2, L3 = Adjustable External Travel Switches

This option allows up to 3 external switches to be included with the GSX Series Actuator. These switches provide travel indication to the controller and are adjustable (must purchase external anti-rotate for this option). See page 31 for details.

XL = Non-Standard Lubrication

This option provides for indication in the model number that the customer has specified a lubrication other than the standard provided by Exlar, including the use of oil cooling (page 20).

Motor Speed Designators

All Exlar T-LAM™ motors and actuators carry a standard motor speed designator as defined below. This is representative of the standard base speed of the motor, for the selected bus voltage.

If the model number is created and the location for the motor speed designator is left blank, this is the base speed to which each motor will be manufactured. The model number can also be created including this standard speed designator.

Designator	Base Speed	Actuator/Motor Series
-50	5000 rpm	GSX20
-30	3000 rpm	GSX30, GSX40
-24	2400 rpm	GSX50, GSX60
01-99	Special Speed, Consult Exlar	

Exlar also provides the flexibility to manufacture all of its T-LAM products with special base speeds to match the customer's exact application requirements. This may be a higher than standard speed motor, or lower base speed than standard which will allow the customer to get the required torque, at a speed optimized to their application, and use the minimum amount of current from their amplifier.

The call out for a special speed is configured in the model number by using a two digit code from 01-99. These numbers represent the number, in hundreds, of RPM that will be the base speed for the particular motor.

For example, an GSX30-0301-OSM-AD1-118-30 motor that normally has a 3000 rpm standard winding, can be changed to a 3300 rpm winding by changing the -30, to a -33. It can be changed to a 5000 rpm winding by changing the -30 to a -50.

Changing this speed designator will change the ratings of the motor, and these must be obtained from Exlar applications engineers. Also, it is not possible to produce every possible speed from -01 to -99 for each motor at each voltage so please contact Exlar applications engineers for confirmation of the speed that is desired for the application.

Feedback Options

LT = ICT including signal conditioner

This option provides for an actuator containing an internally mounted ICT transducer spanning the full stroke of the actuator. Inquire with Exlar engineering for details and signal conditioner output preference. LT not available with absolute feedback.

Due to the variability in size of some feedback devices, especially absolute feedback devices which are often very large relative to the size of the actuator motor, the actual size of the actuator may differ in length and width from these drawings for feedback types other than standard resolvers and standard encoders. Please consult Exlar for details. In the event that you order an actuator that differs from these standard dimensions, you will be sent a drawing of the final configuration of your actuator for approval.

Motor Options

GSX motor options are described with a 3 digit code. The first digit calls out the stack length, the second the rated bus voltage, and the third the number of poles of the motor. Refer to the mechanical/electrical specifications for motor torque and actuator rated force.

Code	Stack Length	Rated Bus Voltage	Poles	Class
118 =	1 stack	115 Vrms	8 Pole	Class 180 H
138 =		230 Vrms		
158 =		400 Vrms		
168 =		460 Vrms		
218 =	2 stack	115 Vrms	8 Pole	Class 180 H
238 =		230 Vrms		
258 =		400 Vrms		
268 =		460 Vrms		
318 =	3 stack	115 Vrms	8 Pole	Class 180 H
338 =		230 Vrms		
358 =		400 Vrms		
368 =		460 Vrms		

Rod End Attachments

Rear Clevis Pin Spherical Rod Eye Rod Eye Rod Clevis

See drawings on pages 32-35.

Attachments ordered separate from actuator.

Housing Options

FG = Smooth White Epoxy

This option provides for an actuator coated with FDA approved white epoxy.

EN = Electroless Nickel Plating

This option provides for an actuator with electroless nickel plating.

SS = Stainless Steel Housing

This option provides an actuator with all stainless steel construction. Housing dimensions for this option are not equal to the standard housing. Force, torque and current ratings are reduced 25% with this option. Please inquire with Exlar for dimensions and ratings.

HC = Type III Hard Coat Anodized, Class I

This option provides an actuator with type III hard coat anodized coating. Class I, no dye.

XH = Special Housing Option

Any housing option that is not designated by the above codes should be listed as XH and described at time of order. All special options must be discussed with Exlar engineering.

GSX20, Double Side Mounts or Extended Tie Rod Mount

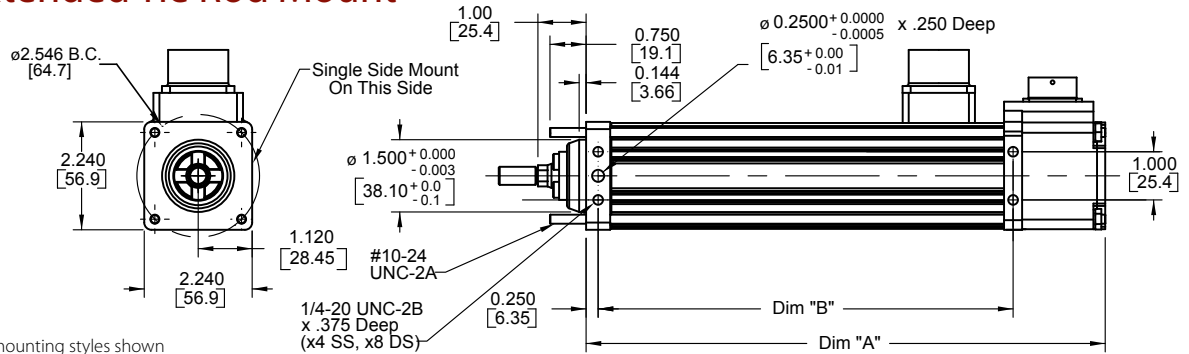

1. Three mounting styles shown
 2. Shown view is standard side for single side mount
- * If "M" metric tie rod option, thread = M5 x 0.8
 * If "J" or "K" metric side mount options, M6 x 1.0 x 9 mm deep with \varnothing 6 mm M7 x 9 mm deep dowel hole

Oil cooling ports on bottom 1/8" NPT (2X)

GSX20 Side Trunnion Mount

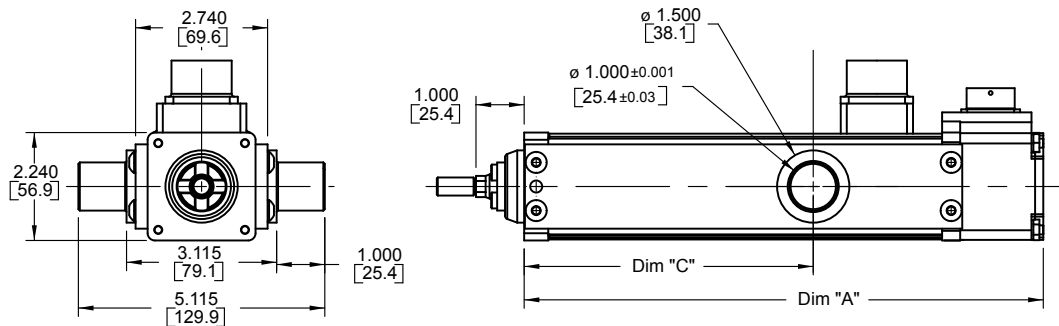

* If "Q" metric side trunnion option, \varnothing 25 mm h7

Oil cooling ports on bottom 1/8" NPT (2X)

GSX20 Rear Clevis Mount or Front Flange Mount

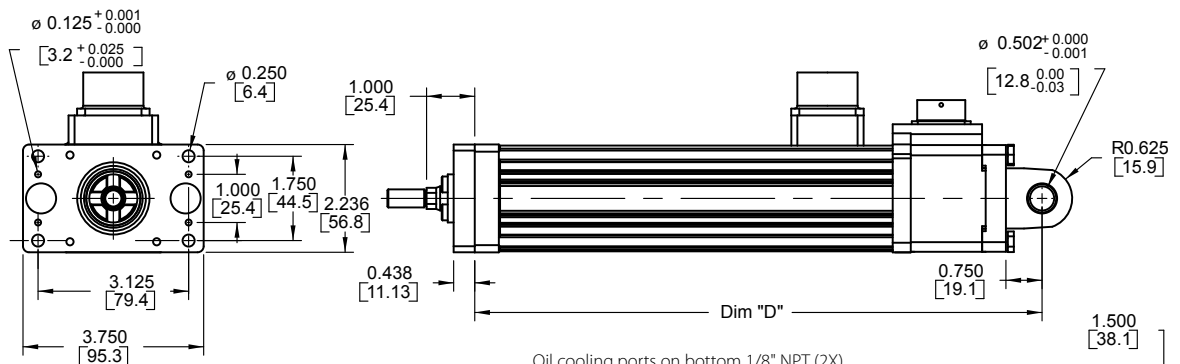

Oil cooling ports on bottom 1/8" NPT (2X)

Dim	3" (76 mm) Stroke in (mm)	6" (152 mm) Stroke in (mm)	10" (254 mm) Stroke in (mm)	12" (305 mm) Stroke in (mm)
A	7.8 (198)	10.8 (274)	14.8 (375)	16.8 (426)
B	5.6 (143)	8.6 (219)	12.6 (320)	14.6 (371)
C	3.0 (76)	6.0 (152)	10.0 (254)	12.0 (305)
D	8.8 (223)	11.8 (299)	15.8 (401)	17.8 (452)

Note: Add 1.784 Inches to Dims "A" & "D" if ordering a Brake.

* If "G" metric clevis option, \varnothing 12 mm +0.01 / -0.06

Drawings subject to change.
Consult Exlar for certified drawings.

Due to the size of many absolute encoders, the selection of such feedback types for the size 20 and 30 actuators results in a larger package size than is shown in the drawings. Consult Exlar for details, or refer to the drawings provided after receipt of order.

1. Two mounting styles shown
2. With flange mount, dimension A is equivalent to the top two drawings

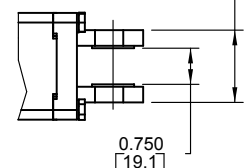

GSX30, Double Side Mounts or Extended Tie Rod Mount

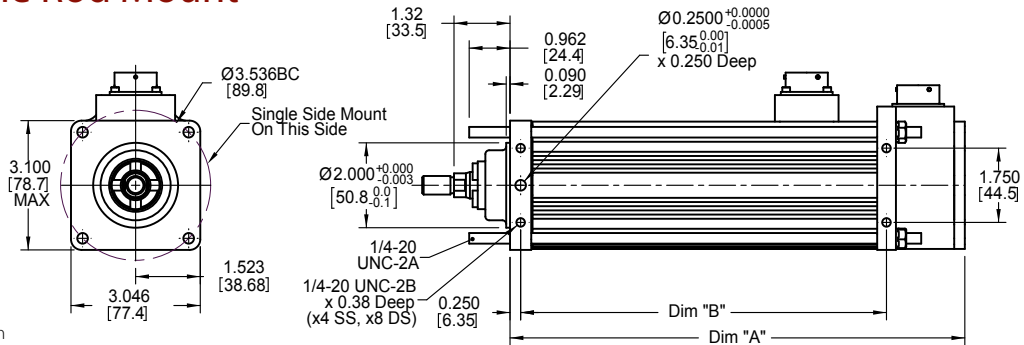

1. Three mounting styles shown
 2. Shown view is standard side for single side mount
- * If "M" metric tie rod option, thread = M6 x 1
 * If "J" or "K" metric side mount options, M6 x 1.0 x 9 mm deep with \varnothing 6 mm M7 x 9 mm deep dowel hole

Oil cooling ports on bottom 1/8" NPT front and 1/4" NPT rear
 If a rear brake is used both ports are 1/8" NPT

GSX30 Side Trunnion Mount

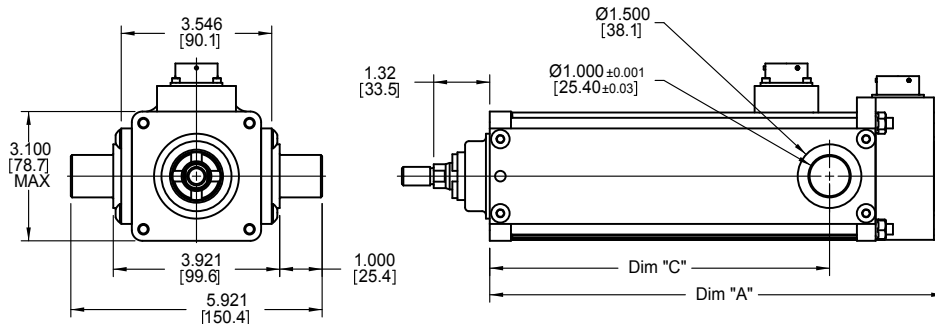

*If "Q" metric side trunnion option, \varnothing 25 mm h7

Oil cooling ports on bottom 1/8" NPT front and 1/4" NPT rear
 If a rear brake is used both ports are 1/8" NPT

GSX30 Rear Clevis Mount or Front Flange Mount

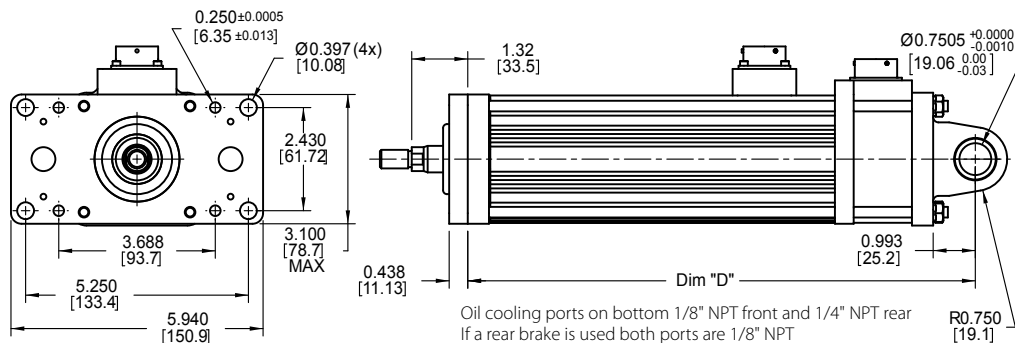

Oil cooling ports on bottom 1/8" NPT front and 1/4" NPT rear
 If a rear brake is used both ports are 1/8" NPT

Dim	3" (76 mm) Stroke in (mm)	6" (152 mm) Stroke in (mm)	10" (254 mm) Stroke in (mm)	12" (305 mm) Stroke in (mm)	14" (355 mm) Stroke in (mm)	18" (457 mm) Stroke in (mm)
A	8.2 (209)	10.7 (272)	15.2 (387)	17.2 (437)	19.2 (488)	23.2 (590)
B	6.1 (156)	8.6 (219)	13.1 (333)	15.1 (384)	17.1 (435)	21.1 (536)
C	5.4 (137)	8.0 (203)	10.0 (254)	12.0 (305)	14.0 (356)	18.0 (457)
D	9.5 (241)	12.0 (304)	16.5 (418)	18.5 (469)	20.5 (520)	24.5 (621)

Note: Add 1.6 Inches to Dims "A & D" if ordering a Brake.

* If "G" metric clevis option, \varnothing 20 mm +0.00 / -0.07

Drawings subject to change.
 Consult Exlar for certified drawings.

Due to the size of many absolute encoders, the selection of such feedback types for the size 20 and 30 actuators results in a larger package size than is shown in the drawings. Consult Exlar for details, or refer to the drawings provided after receipt of order.

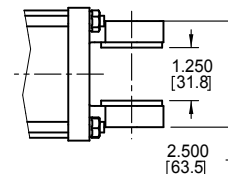

1. Two mounting styles shown
2. With flange mount, dimension A is equivalent to the top two drawings

GSX50 Single, Double Side Mounts or Extended Tie Rod Mount

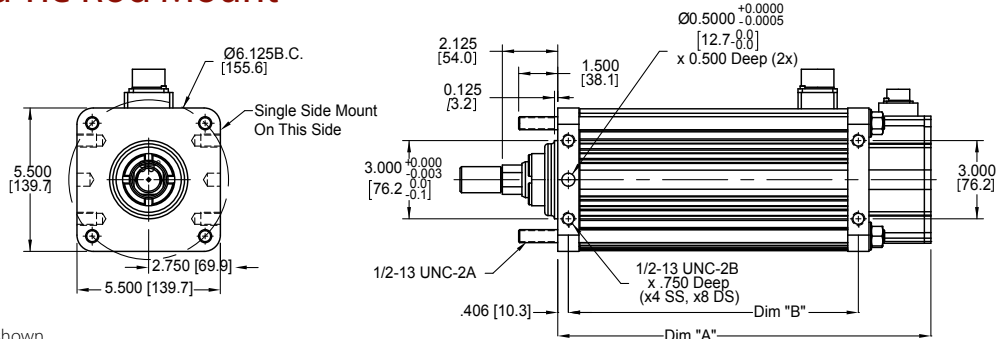

1. Three mounting styles shown
 2. Shown view is standard side for single side mount
- * If "M" metric tie rod option, thread = M12 x 1.75
 * If "J" or "K" metric side mount options, M12 x 1.75 x 19 mm deep with Ø 12 mm M7 x 12 mm deep dowel hole

GSX50 Side Trunnion Mount

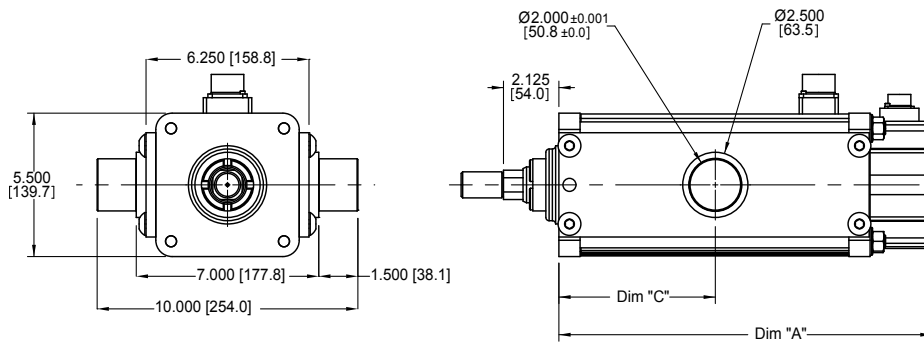

*If "Q" metric side trunnion option, Ø 50 mm h7

GSX50 Rear Clevis Mount or Front Flange Mount

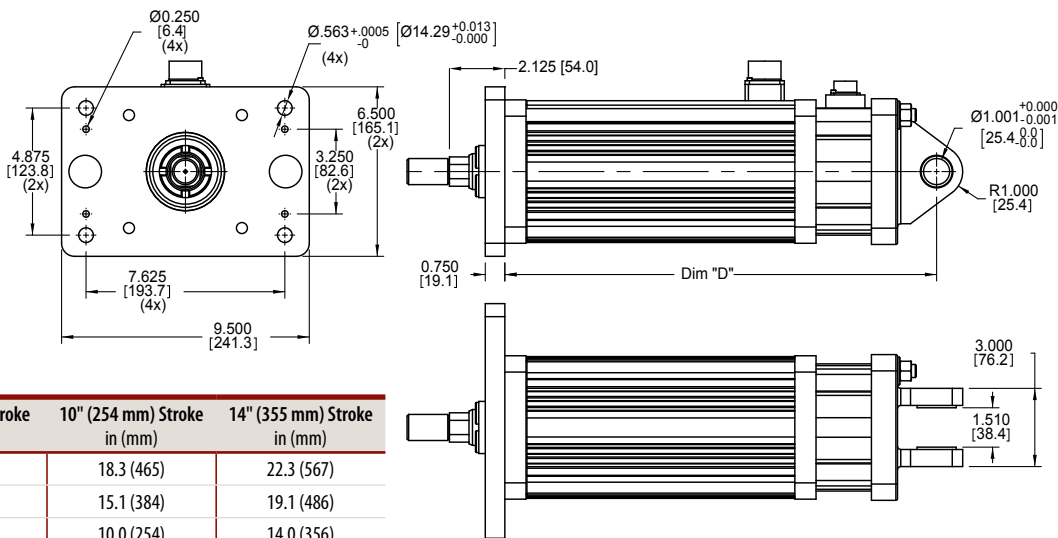

Dim	6" (152 mm) Stroke in (mm)	10" (254 mm) Stroke in (mm)	14" (355 mm) Stroke in (mm)
A	14.3 (364)	18.3 (465)	22.3 (567)
B	11.1 (282)	15.1 (384)	19.1 (486)
C	6.0 (152)	10.0 (254)	14.0 (356)
D	16.6 (421)	20.6 (522)	24.6 (624)

Note: Add 2.5 Inches to Dims "A" & "D" if ordering a Brake.

* If "G" metric clevis option, Ø27 mm +0.00 / -0.06

Drawings subject to change. Consult Exlar for certified drawings.

1. Two mounting styles shown
2. With flange mount, dimension A is equivalent to the top two drawings

GSX60 Single, Double Side Mounts or Extended Tie Rod Mount

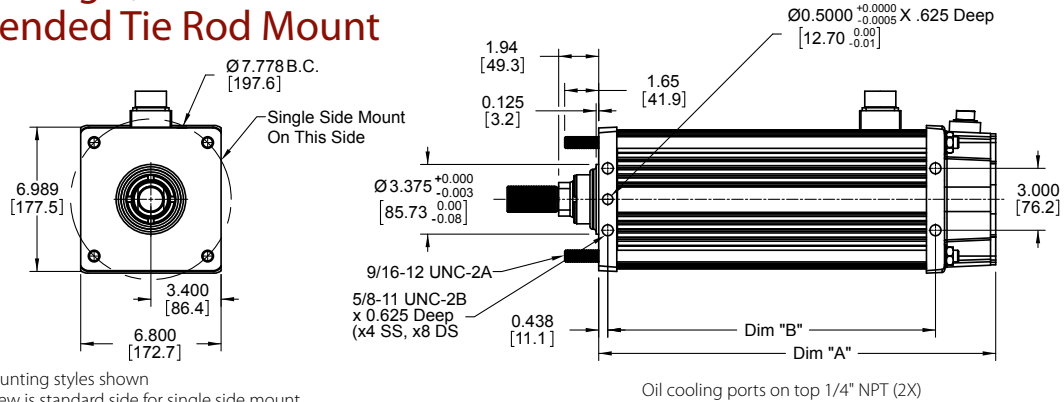

1. Three mounting styles shown
 2. Shown view is standard side for single side mount
- * If "M" metric tie rod option, thread = M14 x 2
 * If "J" or "K" metric side mount options, M16 x 2.0 x 16 mm deep with Ø 12 mm M7 x 12 mm deep dowel hole

Oil cooling ports on top 1/4" NPT (2X)

GSX60 Side Trunnion Mount

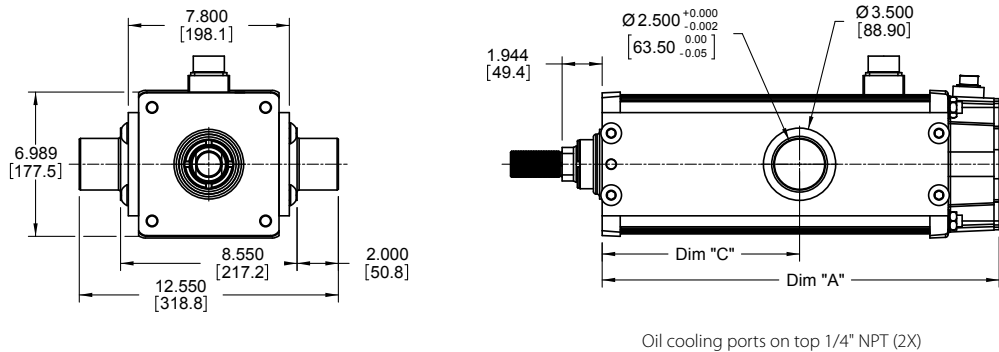

Oil cooling ports on top 1/4" NPT (2X)

- * If "Q" metric side trunnion option, Ø 60 mm h9

GSX60 Rear Clevis Mount or Front Flange Mount

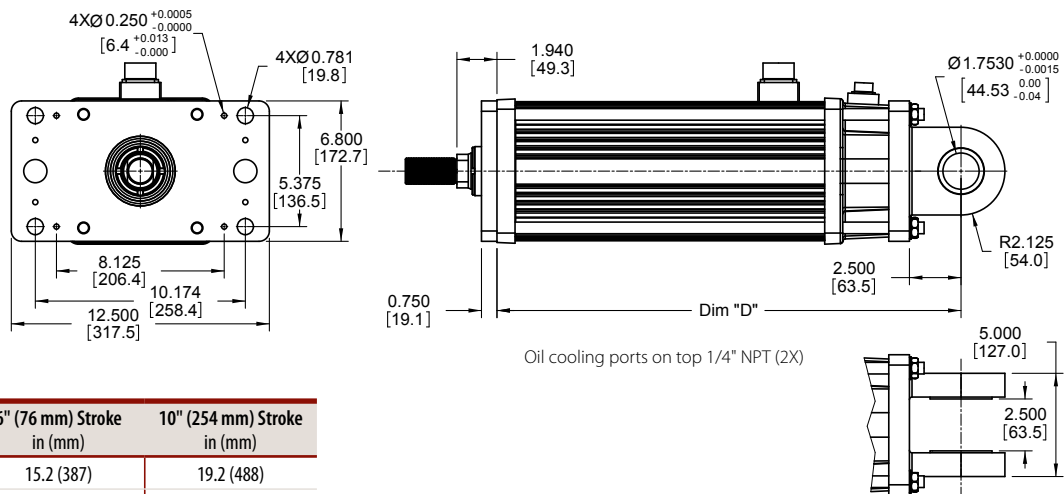

Oil cooling ports on top 1/4" NPT (2X)

Dim	6" (76 mm) Stroke in (mm)	10" (254 mm) Stroke in (mm)
A	15.2 (387)	19.2 (488)
B	11.9 (302)	15.9 (403)
C	6.0 (152)	10.0 (254)
D	18.5 (469)	22.5 (571)

Note: Add 3.58 Inches to Dims 'A' & 'D' if ordering a Brake.

* If "G" metric clevis option, Ø45 mm +0.00 / -0.08

Drawings subject to change. Consult Exlar for certified drawings.

1. Two mounting styles shown
2. With flange mount, dimension A is equivalent to the top two drawings

Rear Brake Extension Option

*Brake connector if needed.

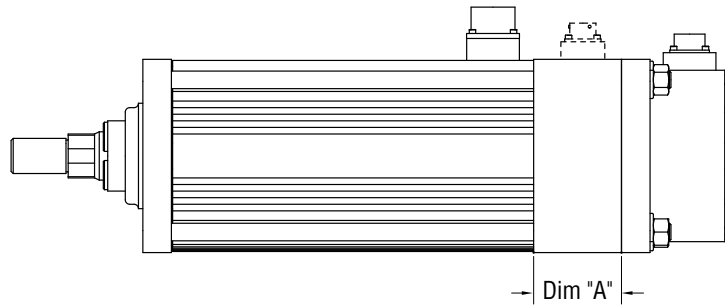

	GSX20	GSX30	GSX40	GSX50	GSX60
A in (mm)	1.78 (45.21)	1.61 (40.9)	2.33 (59.18)	2.5 (63.5)	3.575 (90.8)

*Consult Exlar for connector and wiring information if ordering brake option.

GSX20, GSX30, GSX40, GSX50 & GSX60 External Limit Switch Extension Options

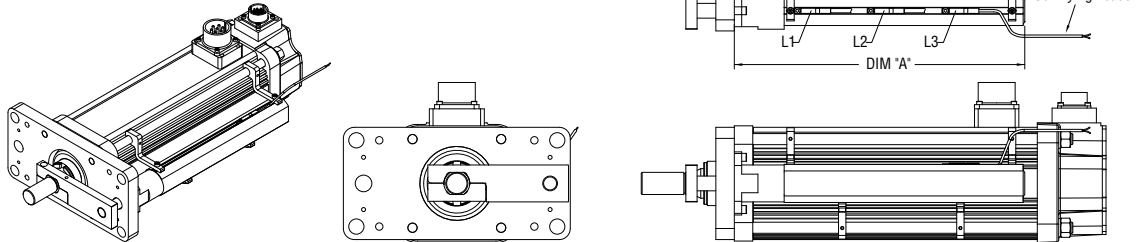

Dim A	3" (76 mm) stroke in (mm)	6" (152 mm) stroke in (mm)	8" (203 mm) stroke in (mm)	10" (254 mm) stroke in (mm)	12" (305 mm) stroke in (mm)	14" (355 mm) stroke in (mm)	18" (457 mm) stroke in (mm)
GSX20	5.515 (140.1)	8.515 (216.3)	NA	12.500 (317.5)	14.515 (368.7)	NA	NA
GSX30	6.932 (176.1)	9.832 (249.7)	NA	13.832 (351.3)	15.832 (402.1)	17.832 (452.9)	21.832 (554.5)
GSX40	NA	9.832 (249.7)	11.83 (300.5)	13.832 (351.3)	15.832 (402.1)	NA	21.832 (554.5)
GSX50	NA	11.667 (296.3)	NA	15.667 (397.9)	NA	19.667 (499.5)	NA
GSX60	NA	10.461 (265.7)	NA	14.461 (367.3)	NA	NA	NA

The external limit switch option (requires anti-rotate option) for the GSX Series of linear actuators provides the user with 1, 2 or 3 externally mounted adjustable switches for use as the end of travel limit switches or home position sensors.

The number of switches desired is selected by ordering the L1, L2 or L3 option, in which 1, 2 or 3 switches will be provided, respectively.

The switches are 9-30 VDC powered, PNP output, with either normally open or normally closed logic operation depending on the switch configuration ordered. Below is a diagram indicating which logic operation will be provided for each switch, based on the option ordered.

Option	SW1	SW2	SW3
L1	Not Supplied	Normally Open	Not Supplied
L2	Normally Closed	Not Supplied	Normally Closed
L3	Normally Closed	Normally Open	Normally Closed

Switch Type	Exlar Part Number	Turck Part Number
Normally Closed Switch	43404	BIM-UNT-RP6X
Normally Open Switch	43403	BIM-UNT-AP6X

Actuator Rod End Options

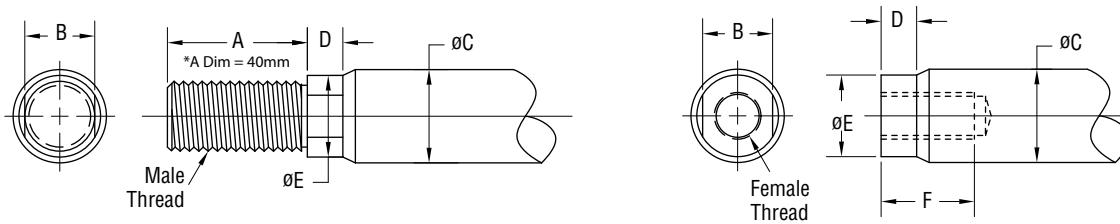

	A	B	øC	D	øE	F	Male U.S.	Male Metric	Female U.S.	Female Metric
GSX20 in (mm)	0.813 (20.7)	0.375 (9.5)	0.500 (12.7)	0.200 (5.1)	0.440 (11.2)	0.750 (19.1)	3/8 – 24 UNF – 2A	M8 x 1 6g	5/16 – 24 UNF – 2B	M8 x 1 6h
GSX30 in (mm)	0.750 (19.1)	0.500 (12.7)	0.625 (15.9)	0.281 (7.1)	0.562 (14.3)	0.750 (19.1)	7/16 – 20 UNF – 2A	M12 x 1.75* 6g	7/16 – 20 UNF – 2B	M10 x 1.5 6h
GSX40 in (mm)	1.500 (38.1)	0.750 (19.1)	1.000 (25.4)	0.381 (9.7)	0.875 (22.2)	1.000 (25.4)	3/4 – 16 UNF – 2A	M16 x 1.5 6g	5/8 – 18 UNF – 2B	M16 x 1.5 6h
GSX50 in (mm)	1.625 (41.3)	1.125 (28.6)	1.375 (34.9)	0.750 (19.1)	1.250 (31.8)	1.750 (44.5)	1 – 14 UNS – 2A	M27 x 2 6g	1 – 14 UNS – 2B	M24 x 2 6h
GSX60 in (mm)	2.500 (63.5)	1.250 (31.8)	1.750 (44.5)	0.550 (14.0)	1.625 (41.3)	1.750 (44.5)	1 1/4 – 12 UNF – 2A	M30 x 2 6g	7/8 – 14 UNF – 2B	M25 x 1.5 6h

Part numbers for rod attachment options indicate the through hole size or pin diameter. Before selecting a spherical rod eye for use with a GSX series actuator, please consult the information on the anti-rotation option for the GSX actuators. Spherical rod eyes will allow the rod to rotate if the load is not held.

Rod Clevis Dimensions

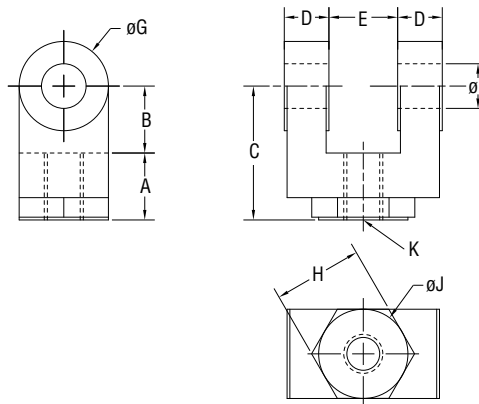

	A	B	C	D	E	øF	øG	H	øJ	K
GSX20 RC038 in (mm)	0.787 (20)	0.787 (20)	1.574 (40)	0.287 (7.3)	0.375 (9.5)	0.375 (9.5)	0.75 (19.1)	NA	NA	3/8-24
GSX30 RC050 in (mm)	0.75 (19.1)	0.75 (19.1)	1.50 (38.1)	0.50 (12.7)	0.765 (19.43)	0.50 (12.7)	1.00 (25.4)	1.00 (25.4)	1.00 (25.4)	7/16-20
GSX40 RC075 in (mm)	1.125 (28.58)	1.25 (31.75)	2.375 (60.3)	0.625 (15.88)	1.265 (32.13)	0.75 (19.1)	1.50 (38.1)	1.25 (31.75)	1.25 (31.75)	3/4-16
GSX50 RC100 in (mm)	1.625 (41.2)	1.500 (38.1)	3.125 (79.4)	0.750 (19.1)	1.515 (38.5)	1.000 (25.4)	2.000 (50.8)	1.500 (38.1)	1.500 (38.1)	1-14
GSX60 RC138 in (mm)	2.00 (50.8)	2.125 (53.98)	4.125 (104.78)	1.00 (25.4)	2.032 (51.6)	1.375 (34.93)	2.75 (69.85)	2.00 (50.8)	2.00 (50.8)	1-1/4-12

Drawings subject to change. Consult Exlar for certified drawings.

Spherical Rod Eye Dimensions

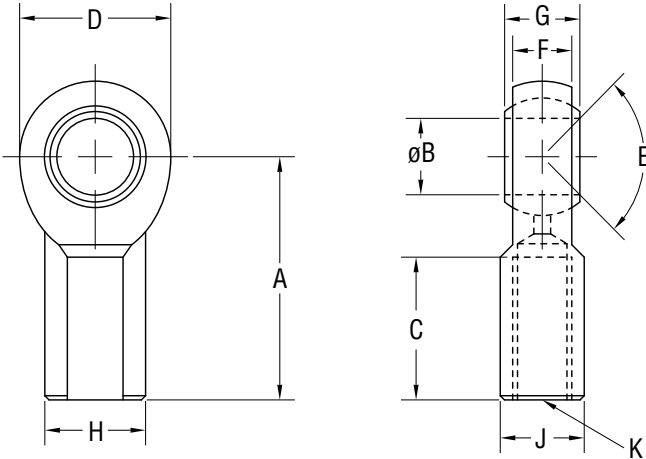

	A	ϕB	C	D	E	F	G	H	J	K
GSX20 SRM038 in (mm)	1.625 (41.3)	.375 (9.525)	.906 (23.0)	1.0 (25.6)	12 deg	.406 (10.3)	.500 (12.7)	.688 (17.7)	.562 (14.3)	3/8-24
GSX30 SRM044 in (mm)	1.81 (46.0)	0.438 (11.13)	1.06 (26.9)	1.13 (28.7)	14 deg	0.44 (11.1)	0.56 (14.2)	0.75 (19.1)	0.63 (16.0)	7/16-20
GSX40 SRM075 in (mm)	2.88 (73.2)	0.75 (19.1)	1.72 (43.7)	1.75 (44.5)	14 deg	0.69 (17.5)	0.88 (22.3)	1.13 (28.7)	1.00 (25.4)	3/4-16
GSX50 SRM100 in (mm)	See GSX50 Special Rod Eye drawing below. Requires female rod end.									

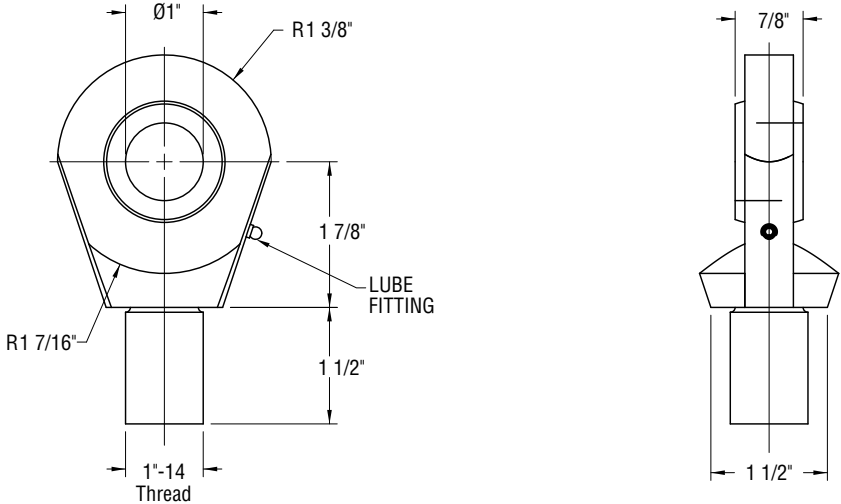

Drawings subject to change. Consult Exlar for certified drawings.

Rod Eye Dimensions

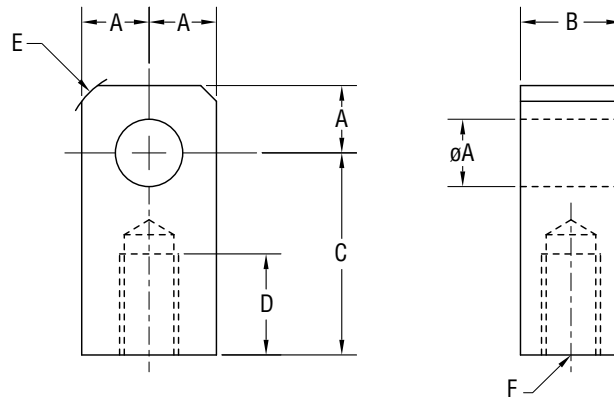

	øA	B	C	D	E	F
GSX20 RE038 in (mm)	0.50 (12.7)	0.560 (14.2)	1.000 (25.4)	0.500 (12.7)	0.25 x 45°	3/8 - 24
GSX30 RE050 in (mm)	0.50 (12.7)	0.75 (19.1)	1.50 (38.1)	0.75 (19.1)	0.63 (15.9)	7/16 - 20
GSX40 RE075 in (mm)	0.75 (19.1)	1.25 (31.8)	2.06 (52.3)	1.13 (28.7)	0.88 (22.3)	3/4 - 16
GSX50 RE100 in (mm)	1.00 (25.4)	1.50 (38.1)	2.81 (71.4)	1.63 (41.4)	1.19 (30.2)	1 - 14
GSX60 RE138 in (mm)	1.375 (34.93)	2.0 (50.8)	3.44 (87.3)	2.0 (50.8)	1.837 (46.67)	1 1/4 - 12

Clevis Pin Dimensions

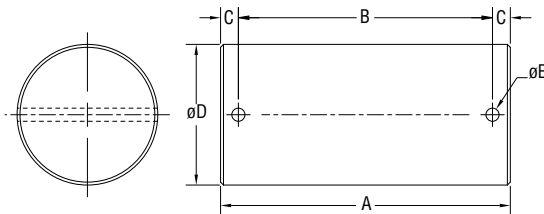

	A	B	C	øD	øE
CP050 ¹ in (mm)	2.28 (57.9)	1.94 (49.28)	0.17 (4.32)	0.50" +0.000/-0.002 (12.7 mm +0.00/-0.05)	0.106 (2.69)
CP075 ² in (mm)	3.09 (78.5)	2.72 (69.1)	0.19 (4.82)	0.75" +0.000/-0.002 (19.1 mm +0.00/-0.05)	0.14 (3.56)
CP100 ³ in (mm)	3.59 (91.2)	3.22 (81.8)	0.19 (4.82)	1.00" +0.000/-0.002 (25.4 mm +0.00/-0.05)	0.14 (3.56)
CP138 ⁴ in (mm)	4.66 (118.3)	4.25 (108)	0.20 (5.08)	1.375" +0.000/-0.002 (34.93 mm +0.00/-0.05)	0.173 (4.39)
CP175 ⁵ in (mm)	5.656 (143.6)	5.25 (133.3)	0.203 (5.15)	1.750" +0.000/-0.002 (44.4 mm +0.00/-0.05)	0.173 (4.39)

¹ Fits GSX20 and GSX30 rear clevis, RC050 and RE050

² Fits GSX30, 40 and RC075, RE075 and SMR075

³ Fits GSX50 rear clevis, RC100, RE100

⁴ Fits RC138, RE138

⁵ Fits GSX60 rear clevis

AA = GSX Actuator Frame Size (Nominal)

- 20 = 2 in (60 mm)
- 30 = 3 in (80 mm)
- 40 = 4 in (100 mm)
- 50 = 5.5 in (140 mm)
- 60 = 7 in (180 mm)

BB = Stroke Length

- 03 = 3 in (75 mm) GSX20, GSX30
- 06 = 5.9 in (150 mm) GSX30
6 in (152 mm) GSX20, GSX40, GSX50, GSX60
- 08 = 8 in (200 mm) GSX40
- 10 = 10 in (250 mm) all models
- 12 = 12 in (300 mm) GSX20, GSX30, GSX40
- 14 = 14 in (355 mm) GSX30, GSX50
- 18 = 18 in (450 mm) GSX30, GSX40

CC = Lead

- 01 = 0.1 in (GSX20, GSX30, GSX40, GSX50)¹²
- 02 = 0.2 in (GSX20, GSX30, GSX40, GSX50)
- 03 = 0.25 in (GSX60)
- 04 = 0.4 in (GSX20 only)
- 05 = 0.5 in (GSX30, GSX40, GSX50, GSX60)
- 08 = 0.75 in (GSX40)⁸
- 10 = 1.0 in (GSX50, GSX60)⁹

D = Connections

- M = Manufacturer's connector⁶
- I = Exlar standard M23 style¹⁰
- A = MS style (anodized)
- D = MS style (electroless nickel)
- B = Embedded leads 3 ft. std.
- P = Embedded leads w/plug 3 ft. std. w/"A" plug
- J = Embedded leads w/"I" plug, 3' standard
- X = Special (please specify)

E = Mounting

- B = Front and rear flange
- C = Rear clevis
- F = Front flange
- R = Rear flange
- S = Side mount
- D = Double side mount
- T = Side trunnion
- E = Extended tie rods
- J = Metric side mount
- K = Metric double side mount
- Q = Metric side trunnion
- M = Metric extended tie rods
- G = Metric rear clevis
- X = Special (please specify)

F = Rod End

- M = Male, US std. thread
- A = Male, metric thread
- F = Female, US std. thread
- B = Female, metric thread
- W = Male, US std. thread 17-4 SS
- R = Male, metric thread 17-4 SS
- V = Female, US std. thread 17-4 SS
- L = Female, metric thread 17-4 SS
- X = Special (please specify)

GGG = Feedback Type (Also specify the Amplifier/Drive Model being used when ordering)

- Standard Incremental Encoder – 2048 line (8192 cts) per rev. index pulse, Hall commutation, 5vdc
- Standard Resolver – Size 15, 1024 line (2048 cts) per rev. two pole resolver
- Motor files for use with select Emerson/CT, Rockwell /AB and Danaher/Kollmorgen Drives are available at www.exlar.com

Custom Feedback - Please consult application engineering:

- XX1 = Wiring and feedback device information must be provided and new feedback callout will be created

Allen-Bradley/Rockwell: (Actuators used with Kinetix and/or Sercos based control systems require a .cmf file from AB/Rockwell. Please contact your AB/Rockwell representative for support.)

- AB8 = Standard Incremental Encoder – MPL Circular (Speedtec) DIN connectors for 'M' option
- AB9 = Hiperface Stegmann SRM050 absolute encoder – 40-50-60 Frame Size. MPL Circular (Speedtec) DIN connectors for 'M' option – Plug & Play feedback option¹⁶
- ABB = Hiperface Stegmann SKM036 multi-turn absolute encoder. 20-30 Frame Size. MPL Circular (Speedtec) DIN connectors for 'M' option – Plug & Play feedback option¹⁶

AMKASYN:

- AK1 = EnDat Heidenhain EQN1325 multi-turn absolute encoder – 40-50-60 Frame Size. DS motor wiring w/M23 euro connectors for 'M' option
- AK2 = EnDat Heidenhain EQN1125 multi-turn absolute encoder – 20-30 Frame Size. DS motor wiring w/M23 euro connectors for 'M' option

Advanced Motion Control:

- AM1 = Standard Incremental Encoder
- AM2 = Encoder 1000 line, w/commutation, 5 VDC
- AM3 = Standard Resolver
- AM5 = Encoder 5000 line, w/commutation, 5 VDC

API Controls:

- AP1 = Standard Resolver
- AP2 = Standard Incremental Encoder

Aerotech:

- AR1 = Encoder 5000 line, w/commutation, 5 VDC
- AR2 = Standard Incremental Encoder

ABB Robot:

- BB1 = LTN Resolver

Baldor:

- BD2 = Std Resolver – BSM motor wiring w/M23 connectors for 'M' option
- BD3 = Std Incremental Encoder – BSM motor wiring w/M23 connectors for 'M' option

Beckhoff:

- BE2 = EnDat Heidenhain EQN1125/EQN1325 multi-turn absolute encoder – AM5XX motor wiring w/M23 euro connectors for 'M' option

Baumüller:

- BM2 = Standard Resolver

B&R Automation:

- BR1 = Standard Resolver

- BR2 = EnDat Heidenhain EQN1325 multi-turn absolute encoder – 8LS/8LM motor wiring w/M23 euro connectors for 'M' option

Comau Robot:

- CM1 = Standard Resolver

Copley Controls:

- CO1 = Standard Incremental Encoder
- CO2 = Standard Resolver

Control Techniques/Emerson:

- CT1 = Hiperface Stegmann SRM050 multi-turn absolute encoder – 40-50-60 Frame Size. FM/UM/EZ motor wiring w/M23 euro connectors for 'M' option
- CT3 = Hiperface Stegmann SKM036 multi-turn absolute encoder – 20-30 Frame Size. FM/UM/EZ motor wiring w/M23 euro connectors for 'M' option
- CT4 = Standard Incremental Encoder – FM/UM/EZ motor wiring w/M23 euro connectors for 'M' option
- CT5 = Std Resolver – FM/UM/EZ motor wiring w/M23 euro connectors for 'M' option
- CT7 = Encoder 5000 line, with commutation, 5 VDC – FM/UM/EZ motor wiring w/M23 euro connectors for 'M' option

Delta Tau Data Systems:

- DT1 = Encoder 1000 line, with commutation, 5 VDC
- DT2 = Standard Resolver

Elmo Motion Control:

- EL1 = Standard Resolver
- EL2 = Standard Incremental Encoder
- EL3 = EnDat Heidenhain EQN1125 multi-turn absolute encoder

Emerson/Control Techniques:

- EM2 = Std Incremental Encoder – NT motor wiring w/MS connectors for 'M' option
- EM5 = Encoder 5000 line, with commutation, 5 VDC – NT motor wiring w/MS connectors for 'M' option

Elau:

- EU1 = Hiperface Stegmann SRM050 multi-turn absolute encoder – 40-50-60 Frame Size. SH motor wiring w/MS connectors for 'M' option
- EU4 = Hiperface Stegmann SKM036 multi-turn absolute encoder – 20-30 Frame Size. SH motor wiring w/MS connectors for 'M' option

Exlar:

- EX4 = Standard Resolver

Fanuc Pulsecoder: Consult Exlar

G&L Motion Control/Danaher Motion:

- GL1 = Std Incremental Encoder – HSM motor wiring w/ MS connectors for 'M' option
- GL2 = Std Incremental Encoder – LSM-MSM motor wiring w/M23 euro connectors for 'M' option
- GL3 = Std Incremental Encoder – NSM motor wiring w/MS connectors for 'M' option
- GL4 = EnDat Heidenhain EQN1125 multi-turn absolute encoder – AKM motor wiring w/M23 euro connectors for 'M' option

Infranor:

- IF1 = Standard Resolver

Indramat/Bosch-Rexroth:

- IN6 = Std Resolver – MKD/MHD motor wiring w/M23 euro connectors for 'M' option

IN7 = Hiperface Stegmann SKM036 multi-turn absolute encoder – MSK motor wiring w/M23 euro connectors for 'M' option – plug & play option

Jetter Technologies:

JT1 = Standard Resolver – JH/JL motor wiring w/M23 euro connectors for 'M' option

Kollmorgen/Danaher:

KM4 = EnDat Heidenhain EQN1325 multi-turn absolute encoder – AKM motor wiring w/M23 euro connectors for 'M' option

KM5 = Standard Resolver – AKM motor wiring w/M23 euro connectors for 'M' option

KM6 = Standard Incremental Encoder – AKM motor wiring w/ M23 euro connectors for 'M' option

Kuka Robot:

KU1 = Tyco Size 21 Resolver

Kawasaki Robot:

KW1 = Kawasaki Special Encoder

Lenze/AC Tech:

LZ1 = Hiperface Stegmann SRM050 multi-turn absolute encoder – MCS motor wiring w/M23 euro connectors for 'M' option

LZ5 = Standard Resolver – MCS motor wiring w/ M23 euro connectors for 'M' option

LZ6 = Standard Incremental Encoder – MCS motor wiring w/ M23 euro connectors for 'M' option

Matuschek:

MC1 = LTN Resolver

Metronix:

MX1 = Standard Resolver

MX2 = Hiperface Stegmann SKM036 multi-turn absolute encoder

MX3 = EnDat Heidenhain EQN1125 multi-turn absolute encoder

Mitsubishi:

MT1 = Mitsubishi Absolute Encoder – HF-SP motor wiring with 'M' option

Modicon:

MD1 = Standard Resolver

Momentum:

MN1 = Hyperface Stegmann SRM050 multi-turn absolute encoder – MN motor wiring w/M23 connectors for 'M' option

MN2 = EnDat Heidenhain EQN1325 multi-turn absolute encoder – MN motor wiring connectors for 'M' option

MN3 = Std incremental encoder – MN motor wiring w/M23 connectors for 'M' option

MN4 = Std resolver – MN motor wiring w/M23 connectors for 'M' option

Moog:

MG1 = Standard Resolver

Motoman Robot:

MM1 = Yaskawa Serial Encoder

Nachi Robot:

NC1 = Tamagawa Serial Encoder

Ormec:

OR1 = Standard Resolver

OR2 = Std Incremental Encoder – G series motor wiring w/ MS connectors for 'M' option

Parker Compumotor:

PC6 = Std Incremental Encoder – SMH motor wiring w/M23 connectors for 'M' option – European only

PC7 = Std Resolver – SMH motor wiring w/M23 connectors for 'M' option – European only

PC8 = Standard Incremental Encoder – MPP series motor wiring w/PS connectors for 'M' option – US Only

PC9 = Hiperface Stegmann SRM050 multi-turn absolute encoder – MPP motor wiring w/PS connectors for 'M' option – US Only

PC0 = Standard Resolver – MPP motor wiring w/PS connectors for 'M' option – US Only

Pacific Scientific:

PS2 = Standard Incremental Encoder

PS3 = Standard Resolver – PMA motor wiring w/M23 connectors for 'M' option

Stober Drives:

SB3 = EnDat Heidenhain EQN1125 multi-turn absolute encoder – ED/EK motor wiring w/M23 euro connectors for 'M' option

Siemens:

SM2 = Standard Resolver – 1FK7 motor wiring w/M23 connectors for 'M' option

SM3 = EnDat Heidenhain EQN1325 multi-turn absolute encoder – 40-50-60 Frame Size. 1FK7 motor wiring w/M23 euro connectors for 'M' option

SM4 = EnDat Heidenhain EQN1125 multi-turn absolute encoder – 20-30 Frame Size. 1FK7 motor wiring w/M23 euro connectors for 'M' option

SM4 = EnDat Heidenhain EQN1125 multi-turn absolute encoder – 20-30 Frame Size. 1FK7 motor wiring w/M23 euro connectors for 'M' option

SM4 = EnDat Heidenhain EQN1125 multi-turn absolute encoder – 20-30 Frame Size. 1FK7 motor wiring w/M23 euro connectors for 'M' option

SEW/Eurodrive:

SW1 = Standard Resolver – CM motor wiring w/ M23 euro connectors for 'M' option

SW2 = Standard Incremental Encoder

SW3 = Hiperface Stegmann SRM050 multi-turn absolute encoder – CM motor wiring w/ M23 euro connectors for 'M' option

SW3 = Hiperface Stegmann SRM050 multi-turn absolute encoder – CM motor wiring w/ M23 euro connectors for 'M' option

SW3 = Hiperface Stegmann SRM050 multi-turn absolute encoder – CM motor wiring w/ M23 euro connectors for 'M' option

SW3 = Hiperface Stegmann SRM050 multi-turn absolute encoder – CM motor wiring w/ M23 euro connectors for 'M' option

SW3 = Hiperface Stegmann SRM050 multi-turn absolute encoder – CM motor wiring w/ M23 euro connectors for 'M' option

SW3 = Hiperface Stegmann SRM050 multi-turn absolute encoder – CM motor wiring w/ M23 euro connectors for 'M' option

SW3 = Hiperface Stegmann SRM050 multi-turn absolute encoder – CM motor wiring w/ M23 euro connectors for 'M' option

SW3 = Hiperface Stegmann SRM050 multi-turn absolute encoder – CM motor wiring w/ M23 euro connectors for 'M' option

SW3 = Hiperface Stegmann SRM050 multi-turn absolute encoder – CM motor wiring w/ M23 euro connectors for 'M' option

SW3 = Hiperface Stegmann SRM050 multi-turn absolute encoder – CM motor wiring w/ M23 euro connectors for 'M' option

SW3 = Hiperface Stegmann SRM050 multi-turn absolute encoder – CM motor wiring w/ M23 euro connectors for 'M' option

SW3 = Hiperface Stegmann SRM050 multi-turn absolute encoder – CM motor wiring w/ M23 euro connectors for 'M' option

SW3 = Hiperface Stegmann SRM050 multi-turn absolute encoder – CM motor wiring w/ M23 euro connectors for 'M' option

SW3 = Hiperface Stegmann SRM050 multi-turn absolute encoder – CM motor wiring w/ M23 euro connectors for 'M' option

SW3 = Hiperface Stegmann SRM050 multi-turn absolute encoder – CM motor wiring w/ M23 euro connectors for 'M' option

SW3 = Hiperface Stegmann SRM050 multi-turn absolute encoder – CM motor wiring w/ M23 euro connectors for 'M' option

SW3 = Hiperface Stegmann SRM050 multi-turn absolute encoder – CM motor wiring w/ M23 euro connectors for 'M' option

SW3 = Hiperface Stegmann SRM050 multi-turn absolute encoder – CM motor wiring w/ M23 euro connectors for 'M' option

SW3 = Hiperface Stegmann SRM050 multi-turn absolute encoder – CM motor wiring w/ M23 euro connectors for 'M' option

SW3 = Hiperface Stegmann SRM050 multi-turn absolute encoder – CM motor wiring w/ M23 euro connectors for 'M' option

SW3 = Hiperface Stegmann SRM050 multi-turn absolute encoder – CM motor wiring w/ M23 euro connectors for 'M' option

Motor Options

XM = Special motor option

XL = Special lubrication food grade or Mobilgrease 28 or use of oil cooling, specify

Housing Options

FG = White epoxy⁵

EN = Electroless nickel plating⁵

HC = Type III hard coat anodized, class I⁵

SS = Stainless steel housing⁵

XH = Special housing option

Absolute Linear Feedback

LT = ICT, including signal conditioner^{1,3}

= Part No. Designator for Specials

Optional 5 digit assigned part number to designate unique model numbers for specials.

1. The dynamic load rating of zero backlash, preloaded screws is 63% of the dynamic load rating of the standard non-preloaded screws. The calculated travel life of a preloaded screw will be 25% of the calculated travel life of the same size and lead of a non-preloaded screw. Preloaded follower is not available with absolute linear (LT) internal feedback option.

2. Stator voltage and pole options allow for catalog rated performance at varying amplifier bus voltages and pole configuration requirements. Refer to performance specification on pages 11-12 for availability of 3 stack stator.

3. Linear feedback is not available in the GSX20 and not available in the GSX30, 14" and 18" or with absolute feedback.

4. The brake option may require a third cable, consult Exlar.

5. These housing options would typically be accompanied by the choice of the electroless nickel connectors if a connectorized unit were selected. This choice may also indicate the need for special material main rods or mounting.

6. Available as described in Feedback Types.

7. Requires AR option.

8. 0.75 lead not available above 12".

9. 1.0 lead not available above 10" stroke.

10. GSX60 uses M40 size 1.5 power connector.

11. If not otherwise specified by the customer, an M24X2 male rod end will be used on the GSX50. See note on page 23.

12. 0.1 lead not available over 10" stroke on GSX50.

13. Not available with absolute feedback.

14. Not available on GSX20.

15. N/A with extended tie rod mounting option.

16. Not compatible with Kinetix 300 Drives.

HHH = Motor Stator – 8 Pole² Class 180H

118 = 1 stack	115 Vrms	158 = 1 stack	400 Vrms
218 = 2 stack		258 = 2 stack	
318 = 3 stack		358 = 3 stack	
138 = 1 stack	230 Vrms	168 = 1 stack	460 Vrms
238 = 2 stack		268 = 2 stack	
338 = 3 stack		368 = 3 stack	

II = Motor Speed

24 = 2400 rpm, GSX50, GSX60

30 = 3000 rpm, GSX30, GSX40

50 = 5000 rpm, GSX20

01- 99 = Customer specified base speed

XX .. XX = Options

Travel Options

PF = Preloaded follower¹

AR = External anti-rotate assembly

RB = Rear electric brake⁴

RD = Rear manual drive¹³

SD = Hex side drive

HW = Side handwheel manual drive, with limit switch¹⁴

PB = Protective bellows¹⁵

SR = Splined main rod¹¹

XT = Special travel option (see pg. 23), high temp bellows¹⁵

L1/L2/L3 = External limit switches⁷