

*Advanced Linear and Rotary Actuators
with Embedded Electronics*

Tritex II™ AC Powered Actuators



EXLAR

Industry's Most Compact All-In-One Linear & Rotary Motion Actuators

By combining the latest electronic power technology with advanced thermal management modeling technology, Exlar has set a benchmark for electric actuator performance versus size. The Tritex II actuators integrate an AC powered servo drive, digital position controller, brushless motor and linear or rotary actuator in one elegant, compact, sealed package. Now, you can distribute motion control and solve your application with one integrated device. Simply connect AC power, I/O, communications and go!



Tritex II System

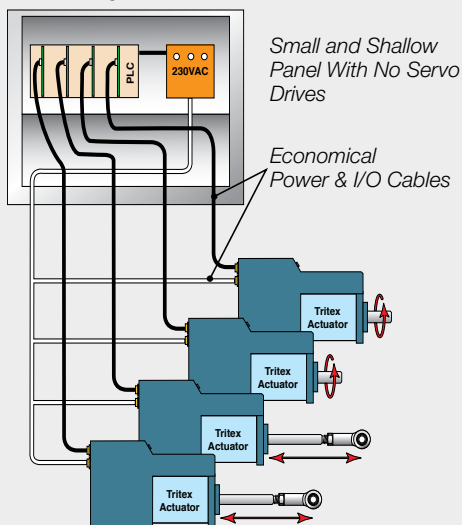

Alternative Systems

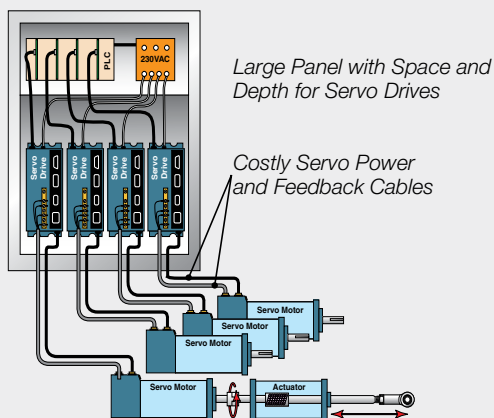

Dramatically Reduce Space Requirements

Tritex II actuators are the highest power density, smallest footprint servo drive devices on the market. Finally, you can incorporate a fully electronic solution in the space of your existing hydraulic or pneumatic cylinder. You can also eliminate troublesome ball screw actuators or bulky servo gear reducers. And the space previously consumed by panel mount servo drives and motion controllers is no longer needed. Tritex II actuators may also reduce the size of your machine design while offering significant reliability improvement.

Reduce Costs

Because the AC powered Tritex II unit houses the servo drive, digital positioner and actuator all in one convenient package, you eliminate the labor costs for mounting and wiring the panels. Cable costs are also significantly reduced by eliminating the need for expensive, high-maintenance specialty servo cables. All that is required is an economical standard AC power cord, and standard communication cable for digital and analog I/O.

Also eliminated are the issues associated with power signals and feedback signals traveling long distances from servo drive to servo motor. With the Tritex II, the servo drive and motor are always integrated in the same housing.

No Compromises on Power, Performance or Reliability

With forces to approximately 4000 pounds (18 kN) continuous and 10,000 pounds peak (44 kN), and speeds to 33 in/sec (800 mm/sec), the AC Tritex II linear actuators also offer a benefit that no other integrated product offers - POWER! No longer are you limited to trivial amounts of force, or speeds so slow that many motion applications are not possible. And the Tritex II with AC power electronics operates with maximum reliability over a broad range of ambient temperatures; -40°C to +65°C.

The AC powered Tritex II actuators contain a 1.5 kW servo amplifier and a very capable motion controller. With standard features such as analog following for position, compound moves, move chaining and individual force/torque control for each move, the Tritex II Series is the ideal solution for most motion applications.

Applications

Flexible Communications

Multiple feedback types, including absolute feedback, allow you to select the system that is best-suited for your application. Digital and analog I/O plus popular communication networks such as Modbus TCP, Ethernet/IP and ProfiNet (future networks include CANopen and Hart) allow the Tritex II to become an integral part of your control architecture or machine control processes.

Linear Applications

Tritex II linear actuators employ Exlar's patented, inverted roller screw mechanism for converting rotary motion to highly robust and long-life linear motion. These characteristics enable the Tritex actuator to solve applications that previously required pneumatic or hydraulic cylinders. No additional mechanisms (such as acme or ball screws) are necessary to convert the actuator's rotary power into linear motion in order to move the load. Simple to configure, yet powerful interface software allows the Tritex II to perform nearly any motion requirements. Moves can be made to incremental or absolute positions, and also to preset forces or to a switch (input). Moves can be initiated by inputs, by other moves, or by events such as reaching a selected force. The Tritex II linear actuator can be programmed to follow an analog command signal, making it ideal for controlling valves and dampers in process control applications.

Rotary Applications

Tritex II rotary motors and gearmotors provide high response and precise control of a rotatable shaft similar to that found in any electric motor. The difference is that with Tritex II you can program (via your PC) the rotational speed and position of the output shaft in response to external commands. For example, the motor can be commanded to rotate at a controlled velocity and precisely stop at a preprogrammed position. You can also program the unit to run at a preset velocity until a switch input is received or a preprogrammed torque level is produced against a load. Alternatively, the rotary Tritex II actuators can be set up to follow an analog signal, either voltage or current, representing your choice of torque, velocity or position. Signals for initiating the preprogrammed velocity and position commands come from optically isolated inputs or via network communications. Likewise, isolated output commands of the status and events allow precise coordination with your system controls or machine operator.



Optional Internal Gear Reducer

If the application requires greater torque and less speed than available with the base unit, the Tritex II is available with an integral servo grade planetary gear reducer. Gear ratios of 4:1 to 100:1 allow the power of Tritex II to be applied over a broad range of torque requirements.



Roller Screw Basics

Exlar's patented, inverted roller screw is a mechanism for converting rotary torque into linear motion, in a similar manner to acme screws or ball screws. But, unlike those devices, roller screws can carry heavy loads for thousands of hours in the most arduous conditions. This makes roller screws the ideal choice for demanding, continuous-duty linear motion applications. The difference is in the roller screw's design for transmitting forces. Multiple threaded helical rollers are assembled in a planetary arrangement around a threaded shaft as seen below, which converts a motor's rotary motion into linear movement of the shaft or nut.

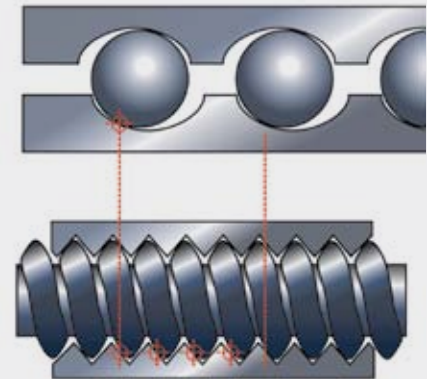

Compare a similar size ball screw to Exlar's planetary roller screw design and see many more contact points on the roller screw. This results in higher load-carrying capacity and improved stiffness.

The Exlar Advantage

Exlar has delivered thousands of roller screw linear actuator solutions around the world in applications ranging from demanding automatic welding to controlling fuel or steam valves on turbine generators. Exlar's linear actuators provide trouble-free, precise linear motion control for millions of cycles of operation.

Typical Applications

- Process Control
- Test
- Simulation
- Food Processing
- Industrial Automation
- Forestry
- Semi-conductor
- Remote Vehicles
- Medical Equipment
- Automotive Assembly
- Molding
- Die Casting
- Welding

Class I Division 2 Rating

Exlar's Tritex II actuators are available for applications requiring CSA Class I Division 2 certification. Ordering a standard I/O interconnect with or without 4-20 mA Analog I/O, and the N option for the NPT port will provide you with Class I Division 2 rated product.

Tritex II 230 V AC Agency Approvals

Agency/Standard	Tritex Models/Options
CE, EMC EN61800-3, Safety EN 61800-5-1	All models
CSA 139	All models
CSA Class I, Div 2	Requires NPT Connection Option. EIP, TCP and ABZ options are not covered
UL 508 C, Type 4 Enclosure	Requires NPT Connection Option. EIP, TCP and ABZ options are not covered
IP 65	Standard on T2X, R2M, R2G models, available on T2M models with P5 option
Vibration Rating	Standard: IEC 61800-5-1 safety standard for drives. 1g peak, up to 150 Hz for <2 hrs. Optional: (HV option) IEC 60068-2-64 random vibration standard, 2.5g rms, 50 to 500 Hz.

Tritex II Models

- T2M standard mechanical capacity actuator, 90 and 115 mm
- T2X high mechanical capacity actuator, 90 and 115 mm
- R2M rotary motor, 90 and 115 mm
- R2G rotary gearmotor, 90 and 115 mm

Power Requirements

- AC Power 100V - 240V, +/- 10%, single phase
- Built-in AC line filter
- Connections for external braking resistor

Feedback Types

- Analog Hall with 1000 count resolution
- Incremental encoder with 8192 count resolution
- Absolute Feedback (analog hall with multi-turn, battery backup)

Communications & I/O

Digital I/O:

- 8 digital inputs
 - 10 to 30 VDC opto-isolated
- 4 digital outputs
 - 30 VDC maximum, 100 mA, opto-isolated

Analog I/O:

- 1 analog input
 - 0-10V or +10V/-10V, 12 bit resolution
 - Force/torque, velocity, position
- 1 analog output
 - 0-10V mode
 - Force/torque, velocity, position
- Optional isolated 4-20mA board
 - 1 4-20 mA isolated analog input, 16 bit resolution
 - 1 4-20 mA isolated analog output, 12 bit resolution

Standard Communications:

- 1 RS 485 port, Modbus RTU, opto-isolated for programming, controlling and monitoring



Tritex II rotary motor with cable glands shown left and Tritex II linear actuator with threaded ports shown below.

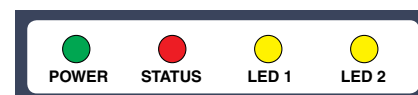

Backpanel LED Display

Tritex II Series Operation

The Tritex II Series actuators can operate in one of five different motion-producing modes. These modes solve an endless variety of applications in industrial automation, medical equipment, fastening and joining, blow molding, injection molding, testing, food processing, and more.

Programmed functions are stored in the Tritex II non-volatile memory. A standard RS/485 serial interface allows control, programming and monitoring of all aspects of the motor or actuator as it performs your application. Optional communications protocols are available.

Operating Modes

1) Move to a position (or switch)

The Tritex II Series actuators allow you to execute up to 16 programmed positions or distances. You may also use a limit switch or other input device as the end condition of a move. This combination of index flexibility provides a simple solution for point-to-point indexing.

2) Move to a preset force or torque

The Tritex II Series allows you to terminate your move upon the achievement of a programmed torque or force. This is an ideal mode for pressing and clamping applications.

3) Position proportional to an analog signal

Ideal for process control solutions, the Tritex II Series provides the functionality to position a control valve by following an analog input signal. This allows the Tritex II Series to deliver precise valve control — control that cannot be achieved by other electric, hydraulic or pneumatic actuators.

4) Velocity proportional to an analog signal

Tritex II actuators offer you the capability to control velocity with an analog signal. This is particularly useful with Tritex II rotary motors offering precise control of the speed of any process or operation.

5) Force/torque proportional to analog signal

Perfect for pressing and torquing applications, you can control torque from an analog input while in torque mode.

Tritex Option Boards

- Option boards offer additional functionality to the base Tritex II actuators
 - Terminal board for customer I/O
 - Terminal board for customer I/O plus encoder output (requires encoder feedback (IE option))
 - Isolated 4-20mA analog input and output
 - Customer specific
- Communication buses
 - EtherNet/IP - Modbus TCP
 - CANopen - PROFINET I/O
 - HART

Connectivity

- Internal terminals accessible through removable cover
- Threaded ports for cable glands
- Optional connectors
 - M23 Power - M16 I/O
- M8 connector for RS485
- M12 connector for Ethernet options
- Custom connection options

Selectable Input Functions

- Enable
- Move (0-15)
- Dedicated Position
- Jog+
- Jog- select move (0-15)
- Jog Fast
- Home
- Extend Switch
- Retract Switch
- Home Switch
- Teach Enable
- Teach Move (0-15)
- Stop
- Hold
- Alternate Mode; allows you to switch between 2 operating modes.

Selectable Output Functions

- Enabled
- Homed
- Ready (Enabled and Homed)
- Fault
- Warning
- Fault or Warning Active
- Move (0-15) in Progress
- Homing
- Jogging
- Jogging+
- Jogging-
- Motion
- In Position
- At Home Position
- At Move (0-15)
- Position
- Stopped
- Holding
- In Current Limit
- In Current Fold back
- Above Rated Current
- Home

Manual Override Options

Handwheel

This option gives you a manual engagement switch that can be used to disable the power to the actuator for manual operation without any external tools.

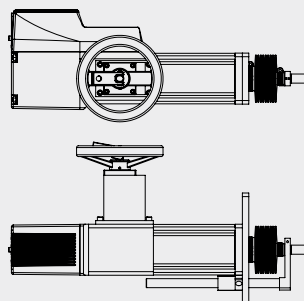

Side Drive

This option allows for emergency operation in a power down condition using a standard socket wrench.

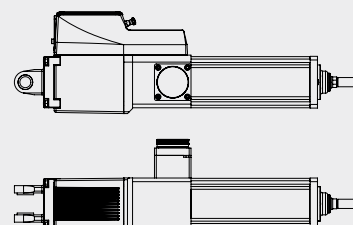

Expert User Interface

Expert, the Tritex II user interface software, provides you with a simple way to select all aspects of configuration and control required to set up and operate a Tritex II actuator. Easy-to-use tabbed pages provide access to input all of the parameters necessary to successfully configure your motion application. 'Application' files give you a convenient way to store and redistribute configurations amongst multiple computers, and 'Drive' files allow the same configuration to be distributed to multiple Tritex II actuators. Motion setup, homing, teach mode, tuning parameters, jogging, I/O configuration, and local control are all accomplished with ease using Expert software.

Protocol Options

The standard communication protocol for Tritex is an RS485 connection using Modbus RTU. The Modbus protocol provides a simple and robust method to connect industrial electronic devices on the same network. The Expert software acts as a Modbus Master and the Tritex II acts as the Slave device, only responding to requests commanded from the software. The Expert software allows full access to commissioning, configuring, monitoring and controlling the Tritex II.

In addition to Modbus RTU communications, the following protocol options are available by selecting communication option boards. Exlar requires initial commissioning of a Tritex II actuator to be performed with the Modbus protocol.

Modbus TCP

Modbus TCP couples Modbus communication structure from Modbus RTU with EtherNet connectivity. The Modbus TCP option is fully supported by the Expert software and offers seamless use for commissioning, configuring, monitoring

and controlling the Tritex II. A Modbus mapping table allows you to map all of the parameters you wish read and modify into a register bank of up to 100 registers. This will allow a PLC program to perform a single read operation and a single write operation to all the parameters.

To maintain standard connectivity, we offer the EtherNet connection through a sealed M12 connector.

EtherNet/IP

EtherNet/IP allows you to change, monitor and control the Tritex II through implicit or explicit messaging initiated from your Rockwell PLC. Tritex parameters are set up through the Expert software using a Tritex II parameter to EtherNet/IP parameter mapping table. Up to 100 input and 100 output 16 bit registers can be mapped to Tritex II parameters.

To maintain standard connectivity, we offer the EtherNet/IP connection through a sealed M12 connector.

CANopen

The Tritex II implementation of CANopen follows the DS402 device profile for motion control distributed through CAN in Automation (CiA). CANopen protocol specifies which identifier is used for predefined purposes.

PROFINET IO

PROFINET IO allows you to change, monitor and control the Tritex II from your Siemens PLC. Tritex parameters are set up through the Expert software using a Tritex II parameter to PROFINET IO parameter mapping table. Up to 100 input and 100 output, 16 bit registers can be mapped to Tritex II parameters. Connection through sealed M12 connector.

HART

The HART Protocol is the global standard for sending and receiving digital information across analog wires between smart devices and the control or monitoring system.

Modbus Mapping Screen

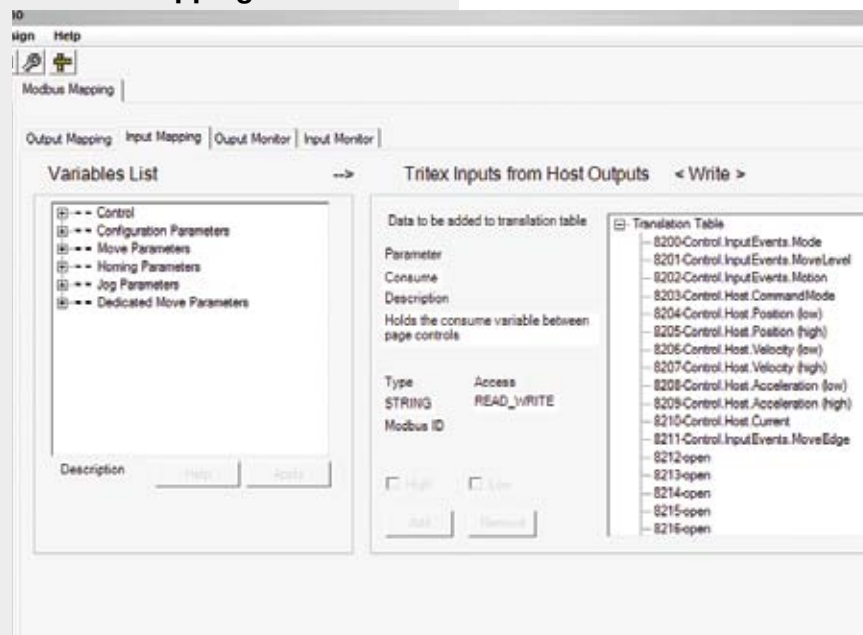

Motion Setup

Exlar configuration provides several templates for various applications. These can serve as your configuration, or as a starting point for your configuration. You can also begin by selecting configuration details specific to your application. You can configure a move to position, move to switch, or move to force motion at the click of a button. The Tritex II products offer absolute and incremental motion, as well as moves ending on a condition such as a specific force or torque.

Control Page

The Expert control page gives you the ability to initiate all motion functions from one single, simple screen. This screen provides you with very easy system start-up and testing without all the inconvenience of machine wiring.

The control page offers the capability to enable and disable the drive and perform fast and slow jogs. This gives you the ability to verify motion before needing any I/O wiring.

Monitoring and Diagnostics

All input functions can be monitored and activated from the Expert monitor page, and all output functions can be monitored. Information on critical fault and status data is available as a separate page, or as a fixed window on the bottom of each page of the software.

Configuring I/O

A pull down menu allows all I/O to be set up in minutes.

Inputs can be configured to be maintained, or momentary, depending on the application requirements. Input and output logic can also be inverted with a simple click.

Homing

You can home to an input, by using a proximity or limit switch, or home to a specific force or torque.

Homing to a force or torque is ideal for setting up applications that require motion referenced to a hard stop, like the closed position of a valve, or the final position of a press.

Teach Mode

In this mode, you can jog the actuator to the desired position, and activate an input, or click a button in the Expert software and the current position of the actuator becomes the defined distance or absolute position associated with a particular move command.

Scope

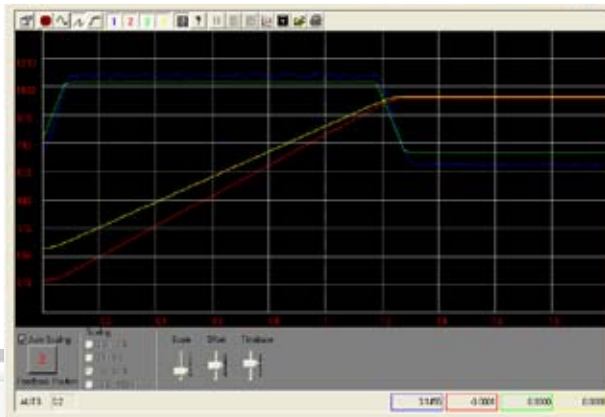

EtherNet/IP Mapping Screen

Parameter	Type	Access
Consume	STRING	READ_WRITE
Description		
Holds the consume variable between page controls		
Type		
Modbus ID		

Translation Table
0-(Reserved)
1-Control Input Events Mode
2-Control Input Events MoveLevel
3-Control Input Events Motion
4-Control Host Command Mode
5-Control Host Position (low)
6-Control Host Position (high)
7-Control Host Velocity (low)
8-Control Host Velocity (high)
9-Control Host Acceleration (low)
10-Control Host Acceleration (high)
11-Control Host Current
12-Control Input Events MoveEdge
13-open
14-open
15-open
16-open

Scope

The Expert Software includes a 4 channel digital oscilloscope feature.

The user can select up to 4 Tritex drive parameters to be monitored simultaneously.

For high speed requirements the data can be captured in the drive's memory at an adjustable rate down to 100 micro sec, then uploaded for plotting. The plots can be saved or printed and the captured data can be saved as a comma separated file for further analysis with Excel.

Travel Life and Temperature Ratings

Travel Life

T2M/T2X Lifetime Curves

The L_{10} expected life of a roller screw linear actuator is expressed as the linear travel distance that 90% of properly maintained roller screws manufactured are expected to meet or exceed. For higher than 90% reliability, the result should be multiplied by the following factors: 95% x 0.62; 96% x 0.53; 97% x 0.44; 98% x 0.33; 99% x 0.21. This is not a guarantee and these charts should be used for estimation purposes only.

The underlying formula that defines this value is:

Travel life in millions of inches, where:
$$L_{10} = \left(\frac{C}{F}\right)^3 \times S =$$

C = Dynamic load rating (lbf)

F = Cubic mean applied load (lbf)

S = Roller screws lead (inches)

All curves represent properly lubricated and maintained actuators.

T2M090 and T2M115
 L_{10} Travel Life

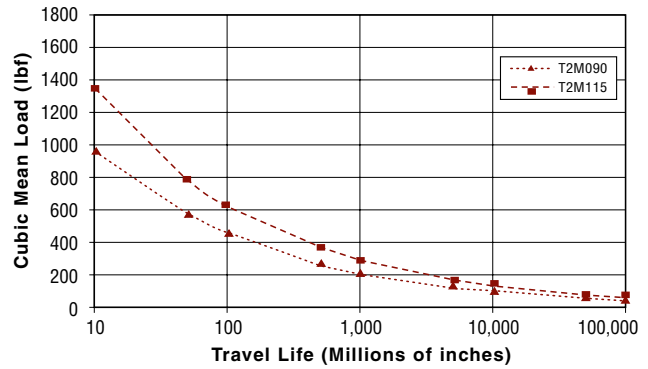

T2X090
 L_{10} Travel Life

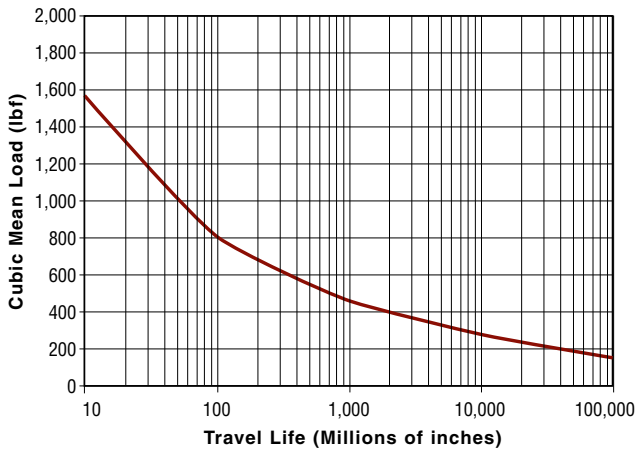

T2X115
 L_{10} Travel Life

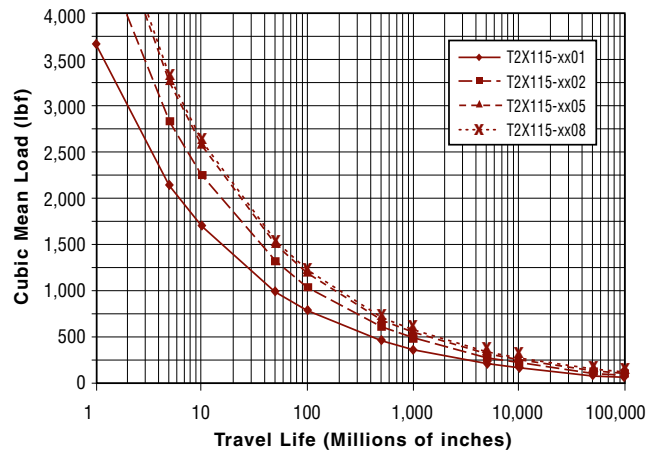

Extended Temperature De-Rating Curve

The speed/torque curves are based on 25° C ambient conditions. The actuators may be operated at ambient temperatures up to 65° C. Use the curve shown right for continuous torque/force deratings above 25° C.

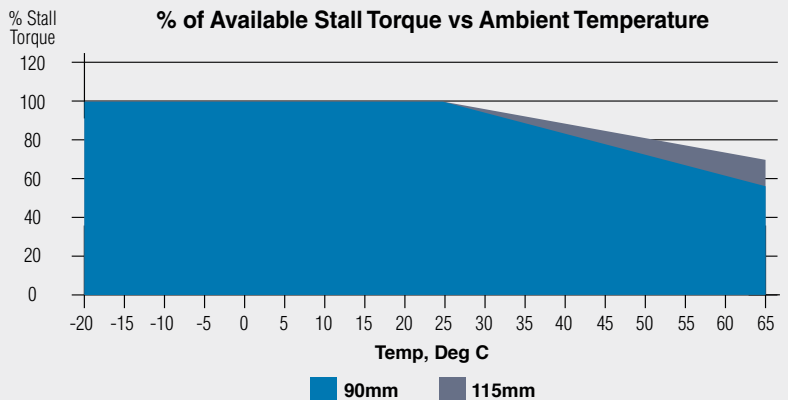

T2M/X090 Linear Actuator Speed vs. Force Curves

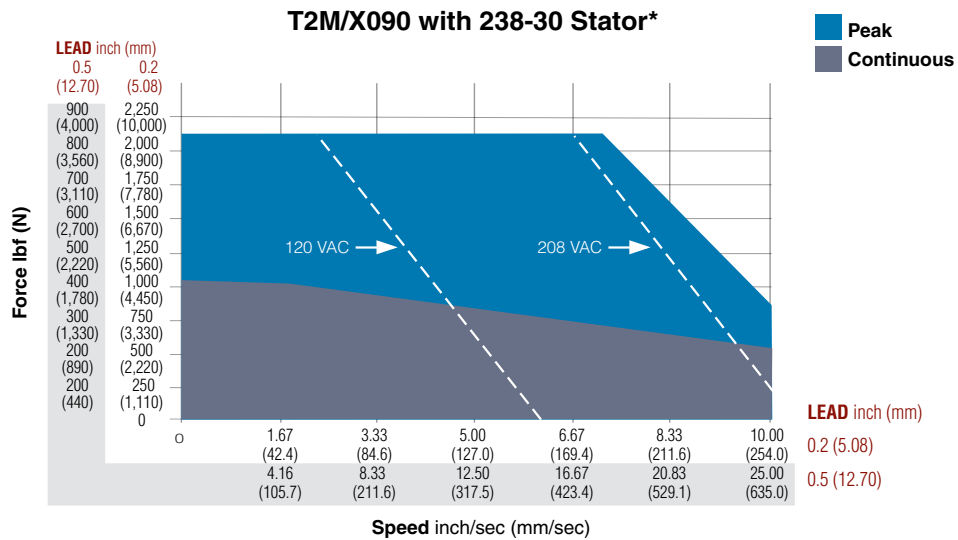
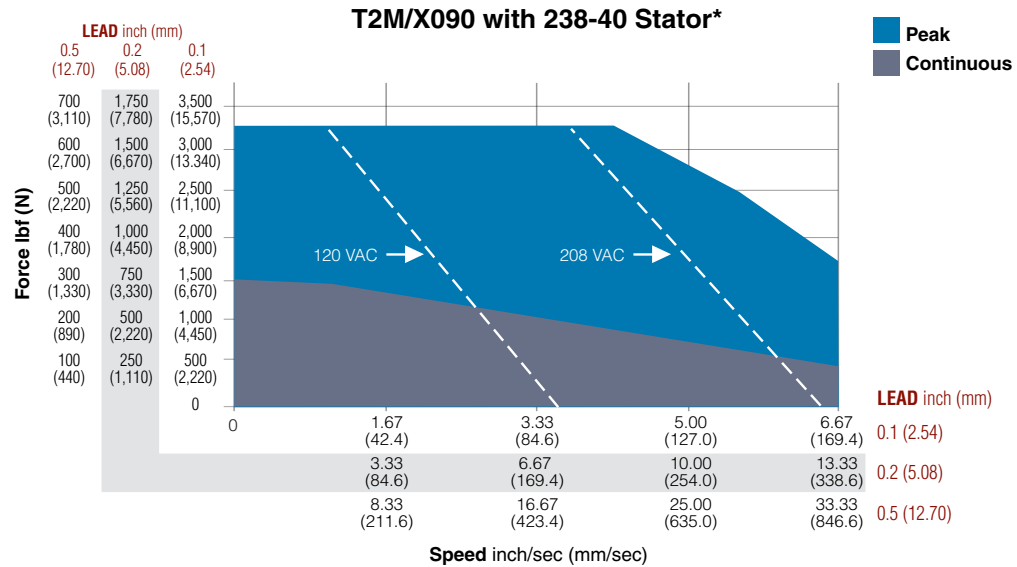
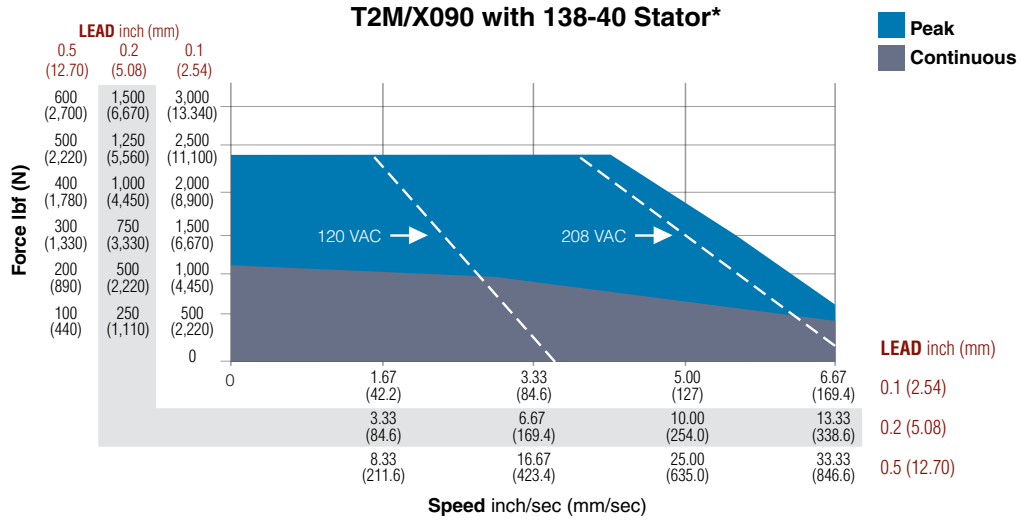

*Test data derived using NEMA recommended aluminum heatsink 10" x 10" x 3/8".

T2M/X115 Linear Actuator Speed vs. Force Curves

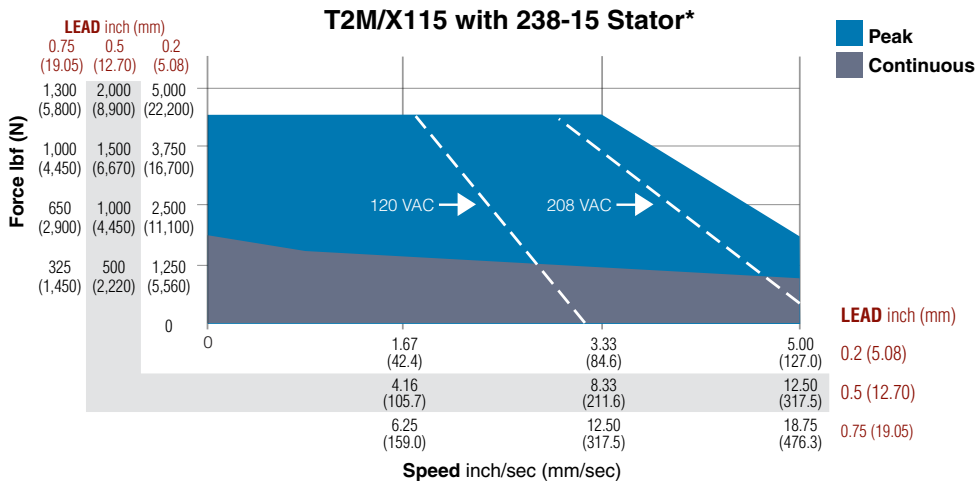
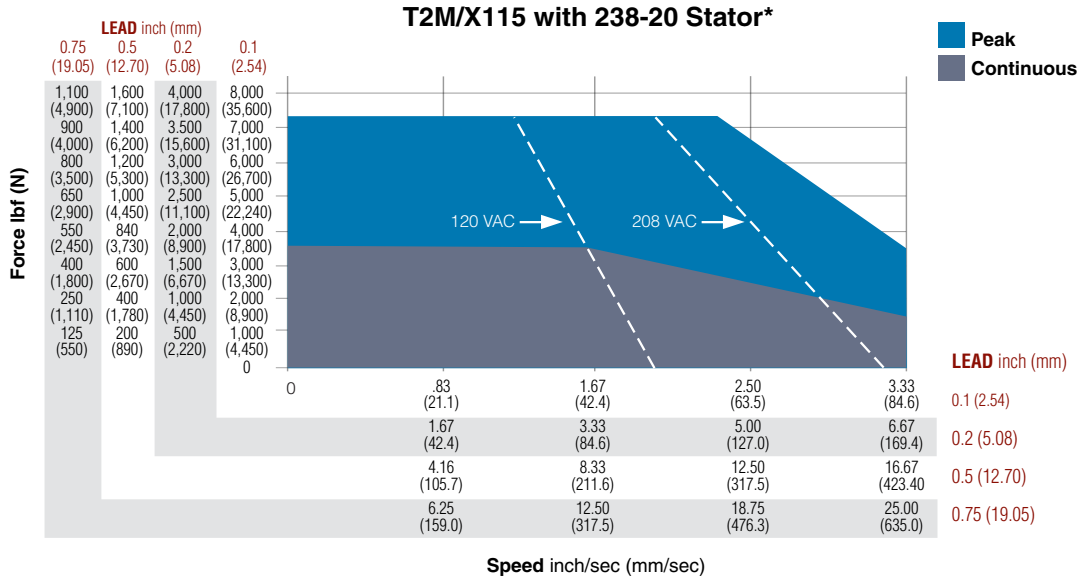
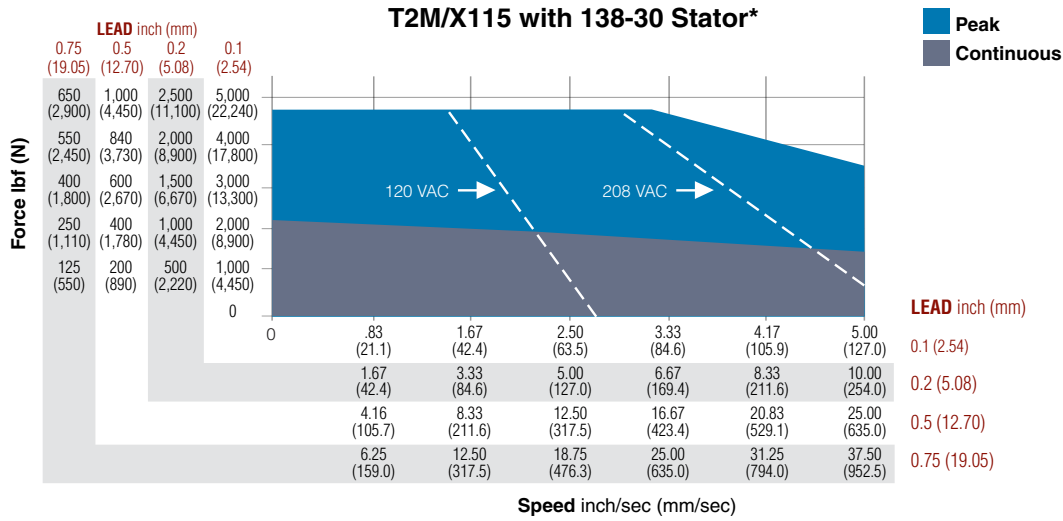

*Test data derived using NEMA recommended aluminum heatsink 12" x 12" x 1/2".

R2M Rotary Motor Speed vs. Torque Curves

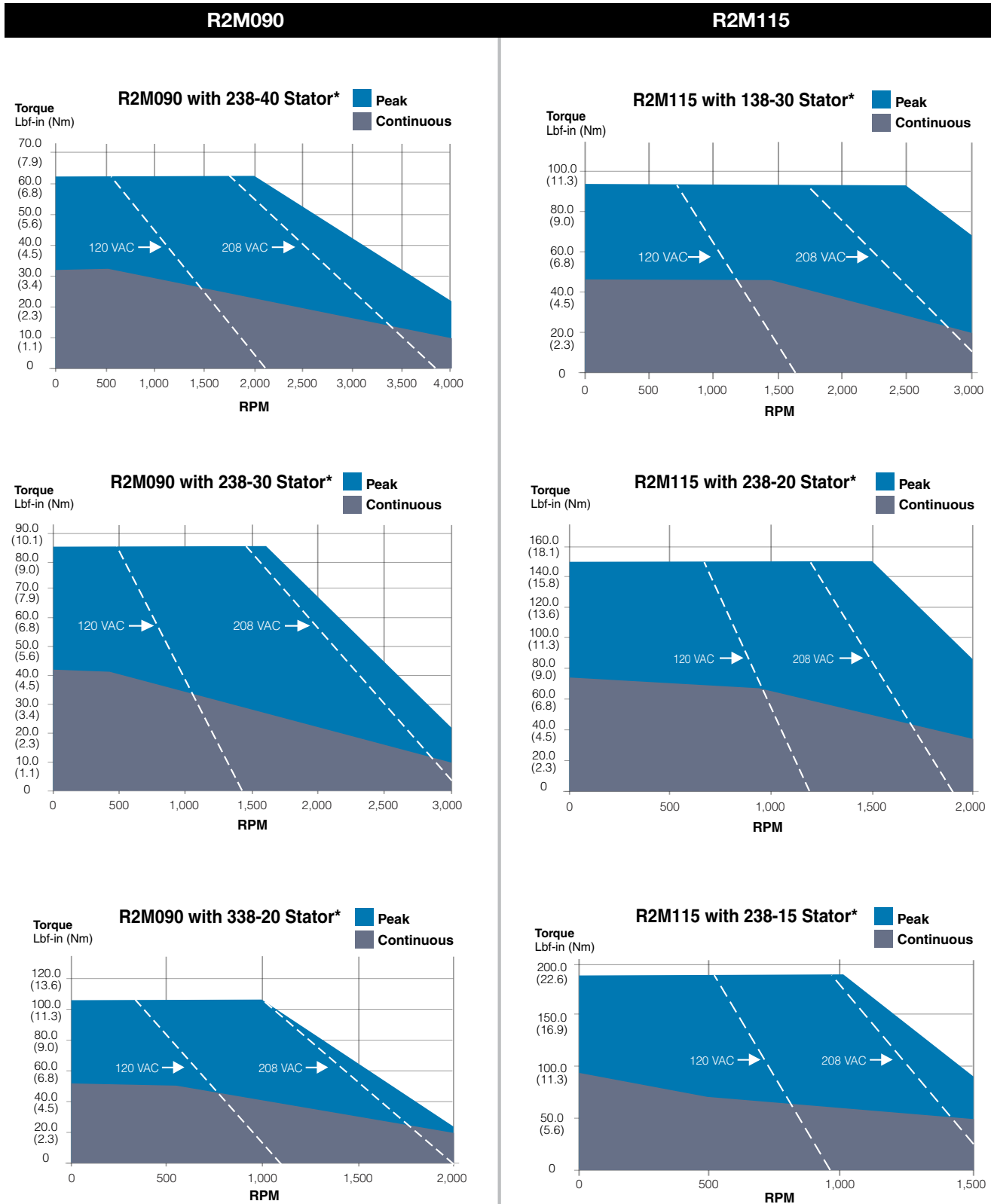

For R2G gearmotors, multiply torque by gear ratio and efficiency. Divide speed by gear ratio.

*R2M090 test data derived using NEMA recommended aluminum heatsink 10" x 10" x 3/8".

*R2M115 test data derived using NEMA recommended aluminum heatsink 12" x 12" x 1/2".

T2M/X Linear Actuator Performance Specifications

T2M/X090 Linear Actuator Performance Specifications						
Backlash		in (mm)	.008 (.20)			
Lead Accuracy		in/ft (mm/300 mm)	.001 (.025)			
Maximum Radial Load		lb (N)	15 (67)			
Environmental Rating: Std		IP54 / IP65				
Lead		Stator	1 Stack 138-40	2 Stack 238-40	2 Stack 238-30	
		RPM @ 240 VAC	4000	4000	3000	
0.1	Continuous Stall Force	lbf (N)	1205 (5360)	1587 (7059)	NA	
	Peak Stall Force	lbf (N)	2411 (10725)	3175 (14123)	NA	
	Max Speed	in/sec (mm/sec)	6.67 (169)	6.67 (169)	NA	
0.2	Continuous Stall Force	lbf (N)	603 (2682)	794 (3532)	1047 (4657)	
	Peak Stall Force	lbf (N)	1205 (5360)	1587 (7059)	2094 (9315)	
	Max Speed	in/sec (mm/sec)	13.33 (338)	13.33 (338)	10.00 (254)	
0.5	Continuous Stall Force	lbf (N)	241 (1072)	317 (1410)	419 (1864)	
	Peak Stall Force	lbf (N)	482 (2144)	635 (2825)	838 (3728)	
	Max Speed	in/sec (mm/sec)	33.33 (846)	33.33 (846)	25.00 (635)	
Drive Current @ Continuous Stall Force		Amps	5.7	7.5	7.5	
Available Stroke Lengths		in (mm)	3 (75), 6 (150), 10 (254), 12 (300), 18 (450)			
Approximate Weight		lb (kg)	14 (6.35) 3 inch stroke, 1 stack	1 (0.5) Added weight per in of stroke	3 (1.4) Added weight per motor stack	3 (1.4) Added weight for brake
Continuous AC Input Current*		Amps	6.3	6.3	6.3	

Continuous input current rating is defined by UL and CSA.
Ratings based on 25°C conditions.

T2M/X115 Linear Actuator Performance Specifications						
Backlash		in (mm)	.008 (.20)			
Lead Accuracy		in/ft (mm/300 mm)	.001 (.025)			
Maximum Radial Load		lb (N)	15 (67)			
Environmental Rating: Std		IP54 / IP65				
Lead		Stator	1 Stack 138-30	2 Stack 238-20	2 Stack 238-15	
		RPM @ 240 VAC	3000	2000	1500	
0.1	Continuous Stall Force	lbf (N)	2354 (10470)	3685 (16391)	NA	
	Peak Stall Force	lbf (N)	4709 (20947)	7370 (32783)	NA	
	Max Speed	in/sec (mm/sec)	5.00 (127)	3.33 (84)	NA	
0.2	Continuous Stall Force	lbf (N)	1177 (5235)	1843 (8198)	2380 (10586)	
	Peak Stall Force	lbf (N)	2354 (10471)	3685 (16392)	4760 (21174)	
	Max Speed	in/sec (mm/sec)	10.00 (254)	6.67 (169)	5.00 (127)	
0.5	Continuous Stall Force	lbf (N)	471 (2095)	737 (3278)	952 (4234)	
	Peak Stall Force	lbf (N)	942 (4190)	1474 (6557)	1904 (8469)	
	Max Speed	in/sec (mm/sec)	25.00 (635)	16.67 (423)	12.50 (317)	
0.75	Continuous Stall Force	lbf (N)	314 (1397)	491 (2184)	635 (2825)	
	Peak Stall Force	lbf (N)	628 (2793)	982 (4368)	1370 (6094)	
	Max Speed	in/sec (mm/sec)	37.5 (953)	25 (635)	18.75 (476)	
Drive Current @ Continuous Stall Force		Amps	8.5	8.5	8.5	
Available Stroke Lengths		in (mm)	6 (150), 10 (254), 12 (300), 18 (450)			
Approximate Weight		lb (kg)	34 (15.5) 6 inch stroke, 1 stack	2 (1) Added weight per in of stroke	8 (4) Added weight per motor stack	4 (2) Added weight for brake
Continuous AC Input Current*		Amps	8.3	8.3	8.3	

Continuous input current rating is defined by UL and CSA.
Ratings based on 25°C conditions.

R2M/R2G090 Rotary Motor/Gearmotor Performance Specifications

R2M090 Rotary Motor Torque and Speed Ratings

	Stator	2 Stack 238-40	2 Stack 238-30	3 Stack 338-20
	RPM at 240 VAC	4000	3000	2000
Continuous Stall Torque	lbf-in (Nm)	30 (3.4)	40 (4.5)	52 (5.9)
Peak Torque	lbf-in (Nm)	60 (6.8)	80 (9.0)	105 (11.9)
Drive Current @ Continuous Stall Torque	Amps	7.5	7.5	6.6
Continuous AC Input Current*	Amps	6.3	6.3	6.3

*Continuous input current rating is defined by UL and CSA. Ratings based on 25°C ambient conditions.

For output torque of R2G gearmotors, multiply by ratio and efficiency. Please note maximum allowable output torques found at bottom of page.

R2M/R2G090 Inertia

	Stator	2 Stack	3 Stack
R2M Motor Armature Inertia (+/-5%)	lb-in-sec ² (kg-cm ²)	0.00097 (1.09)	0.00140 (1.58)
R2G Gearmotor Armature Inertia*	lb-in-sec ² (kg-cm ²)	0.00157 (1.77)	0.00200 (2.26)

*Add armature inertia to gearing inertia for total inertia.

Radial Load and Bearing Life

RPM	50	100	250	500	1000
lbf (N)	389 (1730)	309 (1375)	227 (1010)	180 (801)	143 (636)

Side load ratings shown above are for 10,000 hour bearing life at 25mm from motor face at given rpm.

R2G090 Gearmotor Mechanical Ratings

Model	Ratio	Maximum Allowable Output Torque-Set by User lbf-in (Nm)	Output Torque at Motor Speed for 10,000 Hour Life		
			1000 RPM lbf-in (Nm)	1500 RPM lbf-in (Nm)	2000 RPM lbf-in (Nm)
R2G090-004	4:1	2078 (234.8)	600 (67.8)	552 (62.4)	504 (56.9)
R2G090-005	5:1	1798 (203.1)	775 (87.6)	714 (80.7)	652 (73.7)
R2G090-010	10:1	1126 (127.2)	890 (100.6)	820 (92.7)	750 (84.7)
R2G090-016	16:1	2078 (234.8)	912 (103.4)	830 (94.7)	763 (86.2)
R2G090-020	20:1	2078 (234.8)	980 (110.7)	900 (101.7)	820 (92.6)
R2G090-025	25:1	1798 (203.1)	1250 (141.2)	1150 (130)	1050 (118.6)
R2G090-040	40:1	2078 (234.8)	1200 (135.6)	1107 (125)	1013 (114.4)
R2G090-050	50:1	1798 (203.1)	1550 (169.4)	1434 (162)	1317 (148.8)
R2G090-100	100:1	1126 (127.2)	1100 (124.3)	1100 (124.3)	1100 (124.3)

Two torque ratings for the R2G gearmotors are given in the table above. The left hand columns give the maximum (peak) allowable output torque for the indicated ratios of each size R2G gearmotor. This is not the rated output torque of the motor multiplied by the ratio of the reducer.

It is possible to select a configuration of the motor selection and gear ratio such that the rated motor torque, multiplied by the gear ratio exceeds these ratings. It is the responsibility of the user to ensure that the settings of the system do not allow these values to be exceeded.

The right hand columns give the output torque at the indicated speed which will result in 10,000 hour life (L10). The setup of the system will determine the actual output torque and speed.

R2G090 Gearing Reflected Inertia

Single Reduction			Double Reduction		
Gear Stages	lbf-in-sec ²	(kg-cm ²)	Gear Stages	lbf-in-sec ²	(kg-cm ²)
4:1	0.000154	(0.174)	16:1	0.000115	(0.130)
5:1	0.000100	(0.113)	20:1, 25:1	0.0000756	(0.0854)
10:1	0.0000265	(0.0300)	40:1, 50:1, 100:1	0.0000203	(0.0230)

Backlash and Efficiency

	Single Reduction	Double Reduction
Backlash at 1% Rated Torque	10 Arc min	13 Arc min
Efficiency	91%	86%

R2M090 Motor and RTG090 Gearmotor Weights

	R2M090 without Gears	R2G090 with 1 Stage Gearing	R2G090 with 2 Stage Gearing	Added Weight for Brake
1 Stack Stator	lb (kg)	11 (4.9)	19 (8.6)	22 (10)
2 Stack Stator	lb (kg)	14 (6.4)	22 (10)	25 (11.3)
3 Stack Stator	lb (kg)	17 (7.7)	25 (11.3)	28 (12.7)

R2M/R2G115 Rotary Motor/Gearmotor Performance Specifications

R2M115 Rotary Motor Torque and Speed Ratings

	Stator	1 Stack 138-30	2 Stack 238-20	2 Stack 238-15
	RPM at 240 VAC	3000	2000	1500
Continuous Stall Torque	lbf-in (Nm)	47 (5.3)	73 (8.3)	95 (10.7)
Peak Torque	lbf-in (Nm)	94 (10.6)	146 (16.5)	190 (21.5)
Drive Current @ Continuous Stall Torque	Amps	8.5	8.5	8.5
Continuous AC Input Current*	Amps	8.3	8.3	8.3

*Continuous input current rating is defined by UL and CSA. Ratings based on 25°C ambient conditions.

For output torque of R2G gearmotors, multiply by ratio and efficiency. Please note maximum allowable output torques found at bottom of page.

R2M/R2G115 Inertia

	Stator	1 Stack	2 Stack
R2M Motor Armature Inertia (+/-5%)	lb-in-sec ² (kg-cm ²)	0.00344 (3.89)	0.00623 (7.036)
R2G Gearmotor Armature Inertia*	lb-in-sec ² (kg-cm ²)	0.00538 (6.08)	0.00816 (9.22)

*Add armature inertia to gearing inertia for total R2M system inertia.

Radial Load and Bearing Life

RPM	50	100	250	500	1000
lbf (N)	939 (4177)	745 (3314)	549 (2442)	435 (1935)	346 (1539)

Side load ratings shown above are for 10,000 hour bearing life at 25mm from motor face at given rpm.

R2G115 Gearmotor Mechanical Ratings

Model	Ratio	Maximum Allowable Output Torque-Set by User lbf-in (Nm)	Output Torque at Motor Speed for 10,000 Hour Life		
			1000 RPM lbf-in (Nm)	2000 RPM lbf-in (Nm)	3000 RPM lbf-in (Nm)
R2G115-004	4:1	4696 (530.4)	1392 (157.3)	1132 (127.9)	1000 (112.9)
R2G115-005	5:1	4066 (459.4)	1455 (163.3)	1175 (132.8)	1040 (117.5)
R2G115-010	10:1	2545 (287.5)	1660 (187.6)	1350 (152.6)	1200 (135.6)
R2G115-016	16:1	4696 (530.4)	2112 (238.6)	1714 (193.0)	1518 (171.0)
R2G115-020	20:1	4696 (530.4)	2240 (253.1)	1840 (207.9)	1620 (183.0)
R2G115-025	25:1	4066 (459.4)	2350 (265.5)	1900 (214.7)	1675 (189.2)
R2G115-040	40:1	4696 (530.4)	2800 (316.4)	2240 (253.1)	2000 (225.9)
R2G115-050	50:1	4066 (459.4)	2900 (327.7)	2350 (265.5)	2100 (237.3)
R2G115-100	100:1	2545 (287.5)	2500 (282.5)	2500 (282.5)	2400 (271.2)

Two torque ratings for the R2G gearmotors are given in the table above. The left hand columns give the maximum (peak) allowable output torque for the indicated ratios of each size R2G gearmotor. This is not the rated output torque of the motor multiplied by the ratio of the reducer.

It is possible to select a configuration of the motor selection and gear ratio such that the rated motor torque, multiplied by the gear ratio exceeds these ratings. It is the responsibility of the user to ensure that the settings of the system do not allow these values to be exceeded.

The right hand columns give the output torque at the indicated speed which will result in 10,000 hour life (L10). The setup of the system will determine the actual output torque and speed.

R2G115 Gearing Reflected Inertia

Single Reduction			Double Reduction		
Gear Stages	lbf-in-sec ²	(kg-cm ²)	Gear Stages	lbf-in-sec ²	(kg-cm ²)
4:1	0.000635	(0.717)	16:1	0.000513	(0.580)
5:1	0.000428	(0.484)	20:1, 25:1	0.000350	(0.396)
10:1	0.000111	(0.125)	40:1, 50:1, 100:1	0.0000911	(0.103)

Backlash and Efficiency

	Single Reduction	Double Reduction
Backlash at 1% Rated Torque	10 Arc min	13 Arc min
Efficiency	91%	86%

R2M115 Motor and RTG115 Gearmotor Weights

	R2M115 without Gears	R2G115 with 1 Stage Gearing	R2G115 with 2 Stage Gearing	Added Weight for Brake
1 Stack Stator	lb (kg)	19 (8.6)	34 (15.4)	40 (18.1)
2 Stack Stator	lb (kg)	27 (12.2)	42 (19.1)	48 (21.8)
3 Stack Stator	lb (kg)	35 (15.9)	50 (22.7)	56 (25.4)

T2M/X090 Linear Actuator Dimensions

T2M/X090 Double Side Mount or Extended Tie Rod Mount

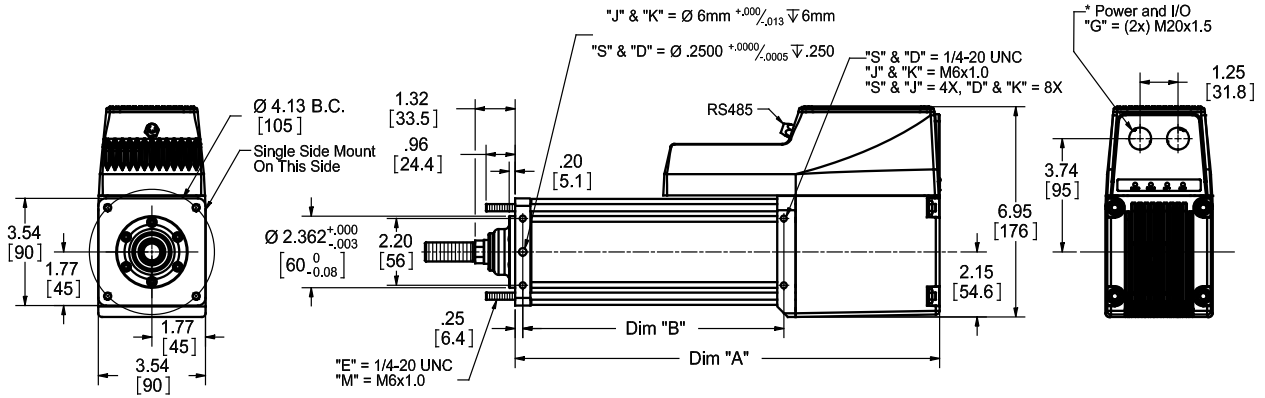

* "N" option utilizes adapter from M20 x 1.5 to 1/2" NPT thread. Dia. 1-5/16 (24mm), length 3/4" (19mm).

T2M/X090 Side Trunnion Mount or Rear Clevis Mount

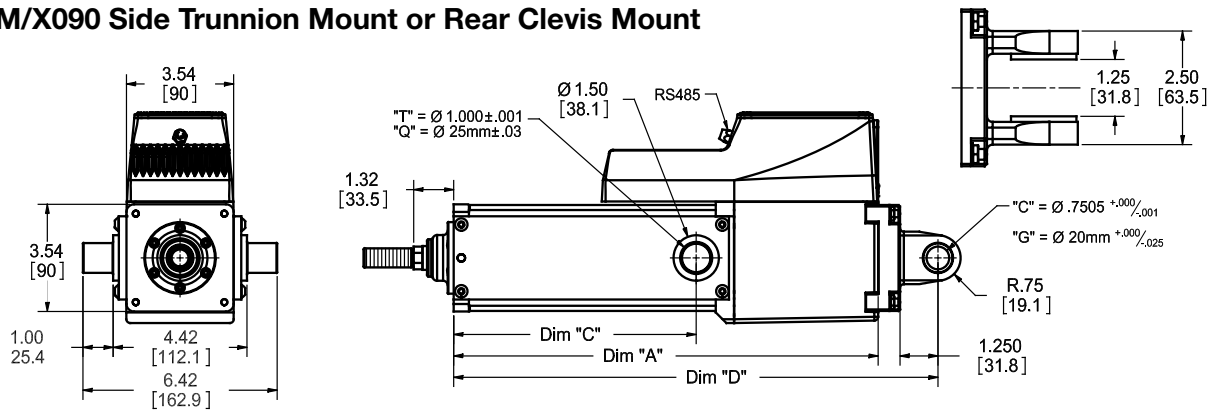

* "N" option utilizes adapter from M20 x 1.5 to 1/2" NPT thread. Dia. 1-5/16 (24mm), length 3/4" (19mm).

T2M/X090 Front, Rear, or Front and Rear Flange Mount

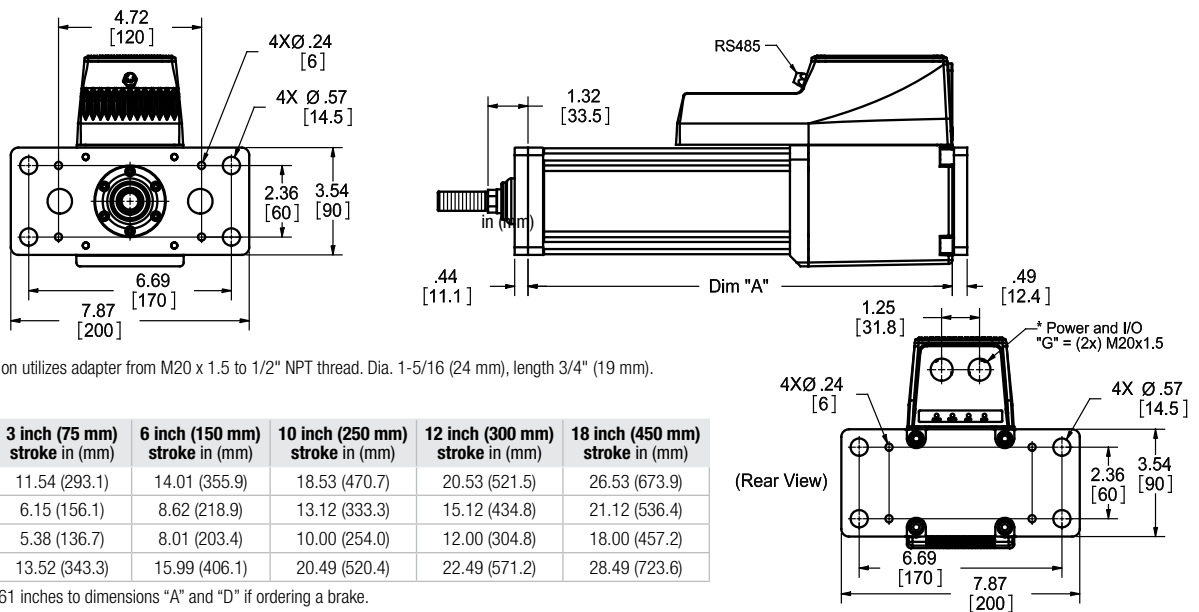

* "N" option utilizes adapter from M20 x 1.5 to 1/2" NPT thread. Dia. 1-5/16 (24 mm), length 3/4" (19 mm).

DIM	3 inch (75 mm) stroke in (mm)	6 inch (150 mm) stroke in (mm)	10 inch (250 mm) stroke in (mm)	12 inch (300 mm) stroke in (mm)	18 inch (450 mm) stroke in (mm)
A	11.54 (293.1)	14.01 (355.9)	18.53 (470.7)	20.53 (521.5)	26.53 (673.9)
B	6.15 (156.1)	8.62 (218.9)	13.12 (333.3)	15.12 (434.8)	21.12 (536.4)
C	5.38 (136.7)	8.01 (203.4)	10.00 (254.0)	12.00 (304.8)	18.00 (457.2)
D	13.52 (343.3)	15.99 (406.1)	20.49 (520.4)	22.49 (571.2)	28.49 (723.6)

Note: Add 1.61 inches to dimensions "A" and "D" if ordering a brake.

T2M/X115 Linear Actuator Dimensions

T2M/X115 Double Side Mount or Extended Tie Rod Mount

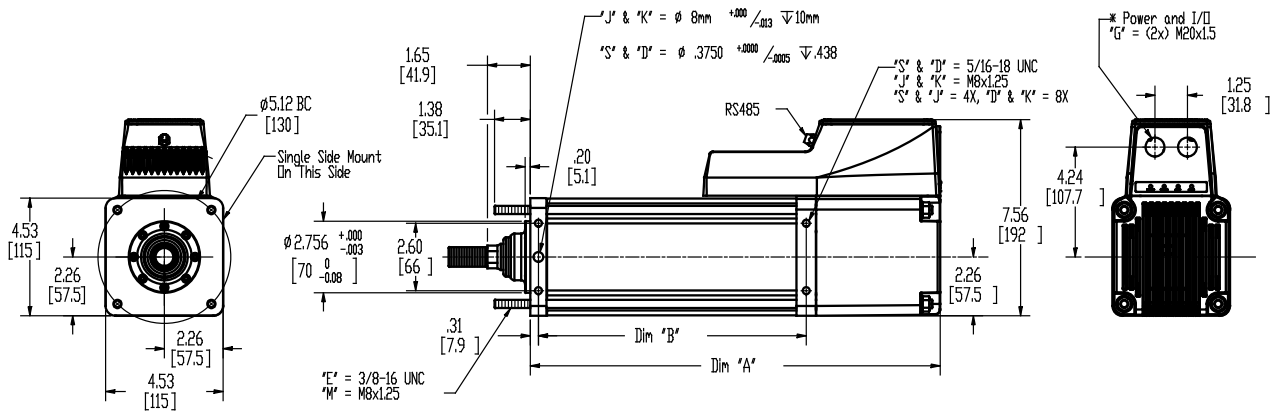

* "N" option utilizes adapter from M20 x 1.5 to 1/2" NPT thread. Dia. 1-5/16 (24mm), length 3/4" (19mm).

T2M/X115 Side Trunnion Mount or Rear Clevis Mount

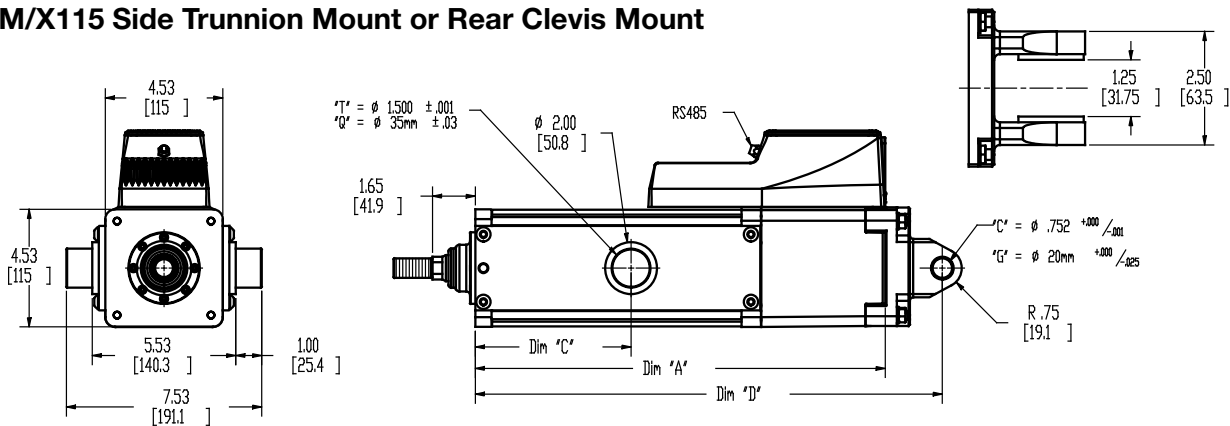

* "N" option utilizes adapter from M20 x 1.5 to 1/2" NPT thread. Dia. 1-5/16 (24mm), length 3/4" (19mm).

T2M/X115 Front, Rear, or Front and Rear Flange Mount

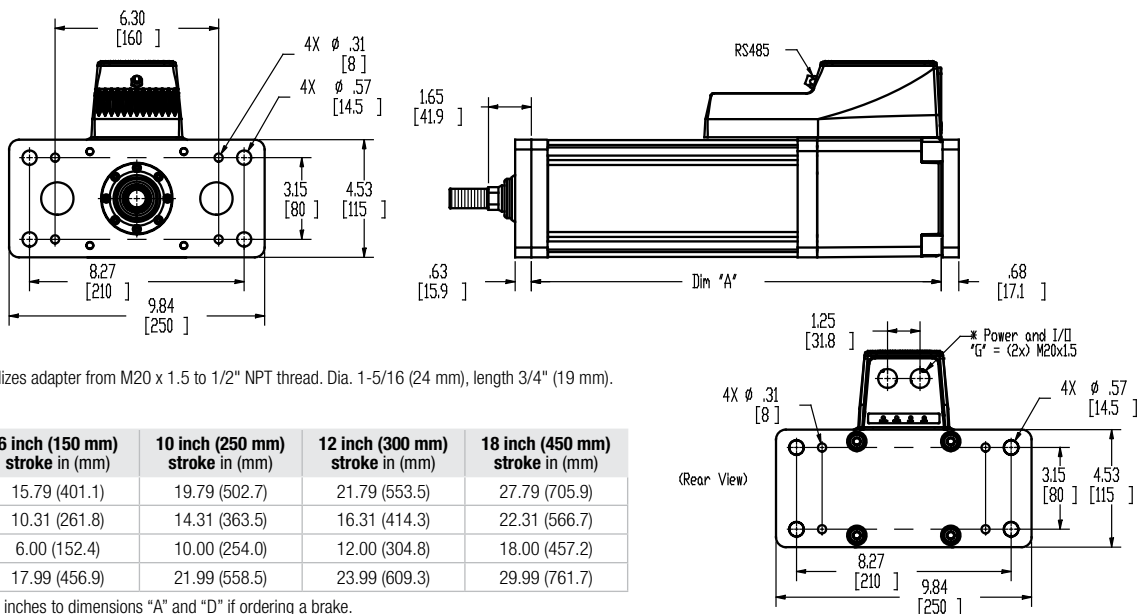

* "N" option utilizes adapter from M20 x 1.5 to 1/2" NPT thread. Dia. 1-5/16 (24 mm), length 3/4" (19 mm).

DIM	6 inch (150 mm) stroke in (mm)	10 inch (250 mm) stroke in (mm)	12 inch (300 mm) stroke in (mm)	18 inch (450 mm) stroke in (mm)
A	15.79 (401.1)	19.79 (502.7)	21.79 (553.5)	27.79 (705.9)
B	10.31 (261.8)	14.31 (363.5)	16.31 (414.3)	22.31 (566.7)
C	6.00 (152.4)	10.00 (254.0)	12.00 (304.8)	18.00 (457.2)
D	17.99 (456.9)	21.99 (558.5)	23.99 (609.3)	29.99 (761.7)

Note: Add 2.33 inches to dimensions "A" and "D" if ordering a brake.

R2M/R2G090 Rotary Motor/Gearmotor Dimensions

R2M090 Dimensions

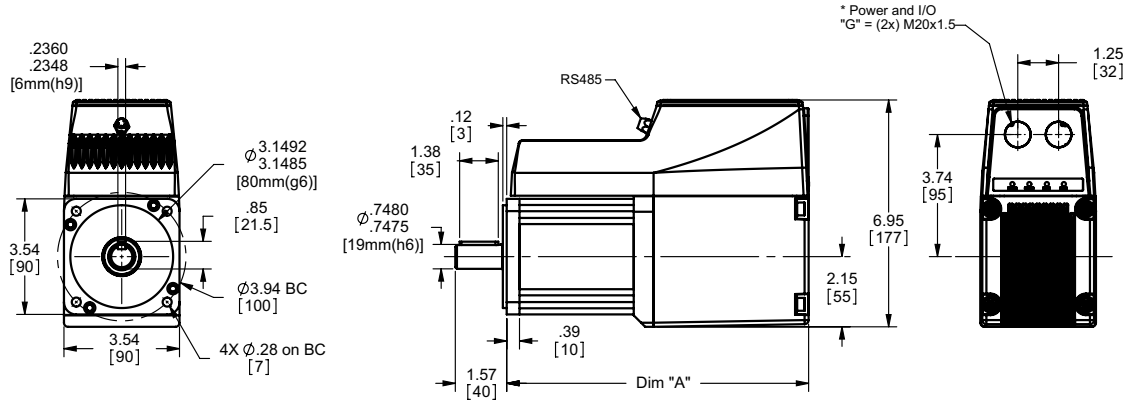

* "N" option utilizes adapter from M20 x 1.5 to 1/2" NPT thread. Dia. 1-5/16 (24mm), length 3/4" (19mm).

Without Brake Option		
DIM	2 Stack Stator	3 Stack Stator
A	9.25 (235.0)	10.25 (260.4)

With Brake Option		
DIM	2 Stack Stator	3 Stack Stator
A	10.6 (269.2)	11.6 (294.6)

R2G090 Dimensions

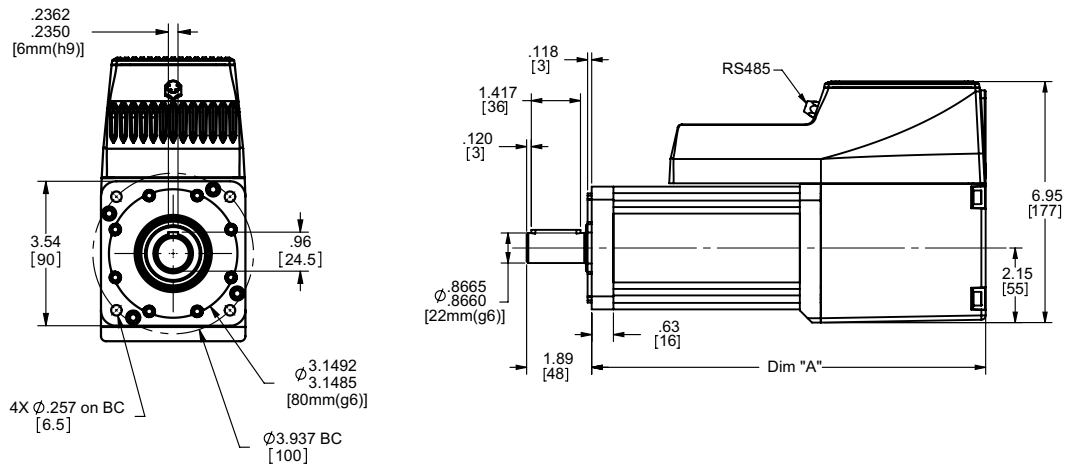

* "N" option utilizes adapter from M20 x 1.5 to 1/2" NPT thread. Dia. 1-5/16 (24mm), length 3/4" (19mm).

Without Brake Option		
DIM	2 Stack Stator 1 Stage Gearhead	3 Stack Stator 1 Stage Gearhead
A	12.36 (313.9)	13.36 (339.3)
DIM	2 Stack Stator 2 Stage Gearhead	3 Stack Stator 2 Stage Gearhead
A	13.63 (346.2)	14.63 (371.6)

With Brake Option		
DIM	2 Stack Stator 1 Stage Gearhead	3 Stack Stator 1 Stage Gearhead
A	13.67 (347.2)	14.67 (372.6)
DIM	2 Stack Stator 2 Stage Gearhead	3 Stack Stator 2 Stage Gearhead
A	14.94 (379.5)	15.94 (404.9)

R2M/R2G115 Rotary Motor/Gearmotor Dimensions

R2M115 Dimensions

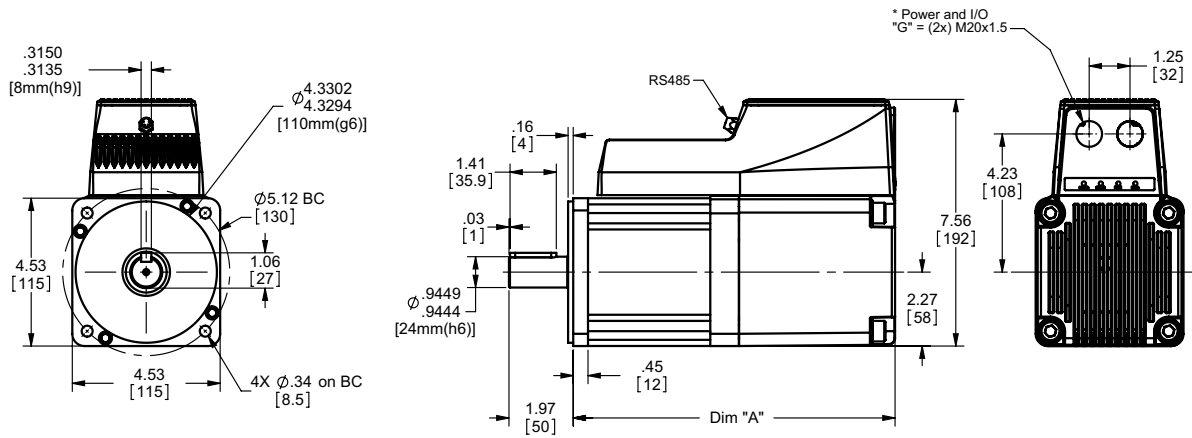

* "N" option utilizes adapter from M20 x 1.5 to 1/2" NPT thread. Dia. 1-5/16 (24mm), length 3/4" (19mm).

Without Brake Option		
DIM	1 Stack Stator	2 Stack Stator
A	9.87 (250.7)	11.87 (301.5)

With Brake Option		
DIM	1 Stack Stator	2 Stack Stator
A	11.60 (294.6)	13.60 (345.4)

R2G115 Dimensions

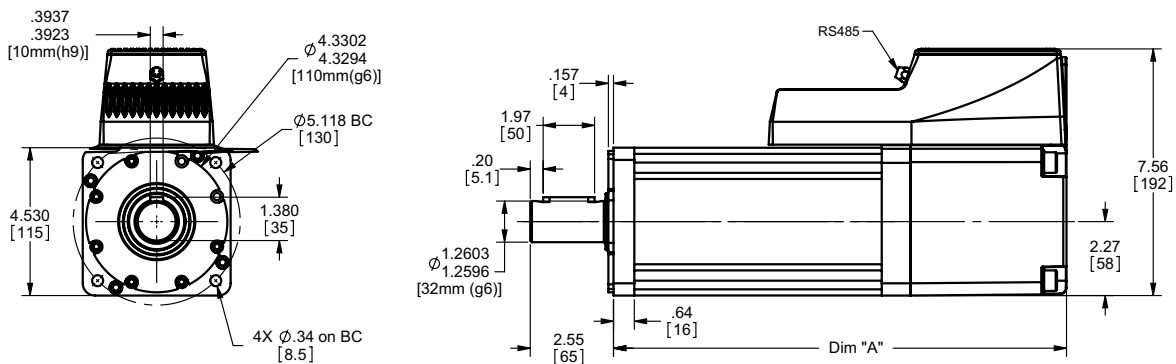

* "N" option utilizes adapter from M20 x 1.5 to 1/2" NPT thread. Dia. 1-5/16 (24mm), length 3/4" (19mm).

Without Brake Option		
DIM	1 Stack Stator 1 Stage Gearhead	2 Stack Stator 1 Stage Gearhead
A	13.88 (352.6)	15.88 (403.4)
DIM	1 Stack Stator 2 Stage Gearhead	2 Stack Stator 2 Stage Gearhead
A	15.49 (393.4)	17.49 (444.2)

With Brake Option		
DIM	1 Stack Stator 1 Stage Gearhead	2 Stack Stator 1 Stage Gearhead
A	15.43 (391.9)	17.43 (442.7)
DIM	1 Stack Stator 2 Stage Gearhead	2 Stack Stator 2 Stage Gearhead
A	17.04 (432.8)	19.04 (483.6)

T2M/X Options and Rod End Attachment Dimensions

Anti-Rotate Option

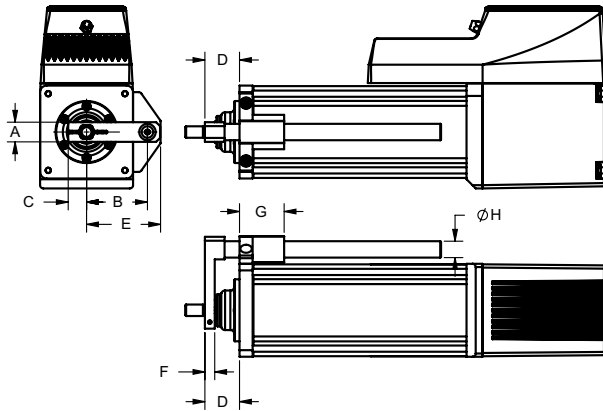

DIM inch (mm)	T2M/X090	T2M/X115
A	0.75 (19.1)	1.13 (28.7)
B	2.32 (58.9)	3.06 (77.7)
C	0.70 (17.8)	1.00 (25.4)
D	1.32 (33.5)	1.65 (41.9)
E	2.82 (71.6)	3.63 (92.2)
F	0.38 (9.7)	0.50 (12.7)
G	1.70 (43.2)	1.97 (50.0)
ØH	0.63 (16.0)	0.75 (19.1)

Actuator Rod End Option

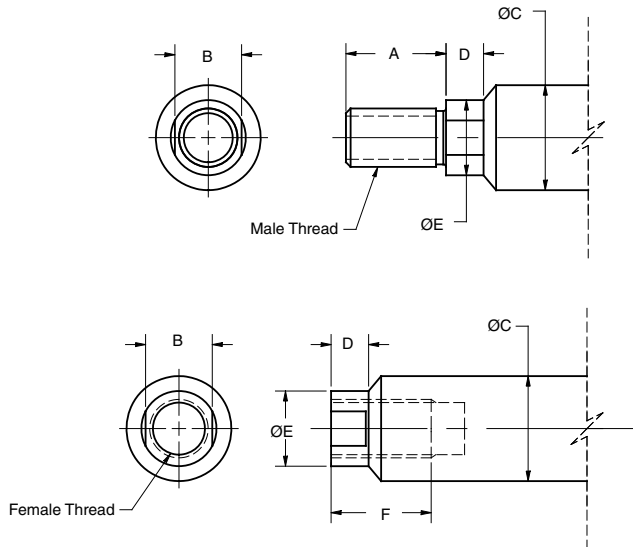

DIM inch (mm)	T2M/X090	T2M/X115
A	1.250 (31.8)	1.500 (38.1)
B	0.625 (17.0)	0.750 (19.1)
ØC	0.787 (20.0)	1.000 (25.4)
D	0.281 (7.1)	0.381 (9.7)
ØE	0.725 (18.4)	0.875 (22.2)
F	1.000 (25.4)	1.000 (25.4)
Male-Inch "M", "W"	1/2-20 UNF-2A	3/4-16 UNF-2A
Male-Metric "A", "R"	M16 x 1.5 6g	M16 x 1.5 6g
Female-Inch "F", "V"	1/2-20 UNF-2B	5/8-18 UNF-2B
Female-Metric "B", "L"	M16 x 1.5 6h	M16 x 1.5 6h

Clevis Pin

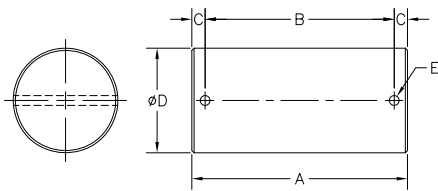

DIM	T2M/X090	T2M/X090	T2M/X115
inch (mm)	CP050 Rod Eye, Rod Clevis	CP075 Rear Clevis	CP075 Rod Eye, Rod Clevis, Spherical Eye, Rear Clevis
A	2.28 (57.9)	3.09 (78.5)	3.09 (78.5)
B	1.94 (49.28)	2.72 (69.1)	2.72 (69.1)
C	0.17 (4.32)	0.19 (4.82)	1.19 (4.82)
ØD	0.50 +0.000/-0.002 (112.7 mm +0.00/-0.05)	0.75 +0.000/-0.002 (19.1 mm +0.00/-0.05)	0.75 +0.000/-0.002 (19.1 mm +0.00/-0.05)
ØE	0.106 (2.69)	0.14 (3.56)	0.14 (3.56)

T2M/X Rod End Attachment Dimensions

Spherical Rod Eye

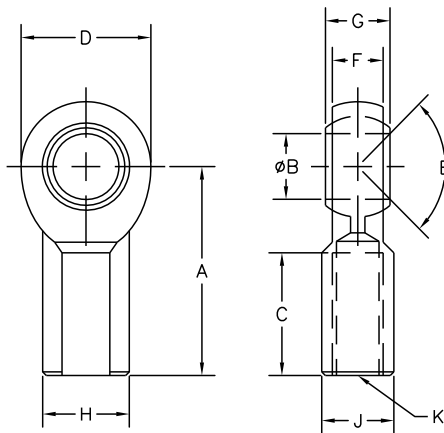

DIM inch (mm)	T2M/X090	T2M/X115
	SRM050	SRM075
A	2.125 (54.0)	2.88 (73.2)
ØB	0.500 (12.7)	0.75 (19.1)
C	1.156 (29.4)	1.72 (43.7)
D	1.312 (33.3)	1.75 (44.5)
E	6 Deg	14 Deg
F	0.500 (12.7)	0.69 (17.5)
G	0.625 (15.9)	0.88 (22.3)
H	0.875 (22.2)	1.13 (28.7)
J	0.750 (19.1)	1.00 (25.4)
K	1/2-20	3/4-16

Rod Eye

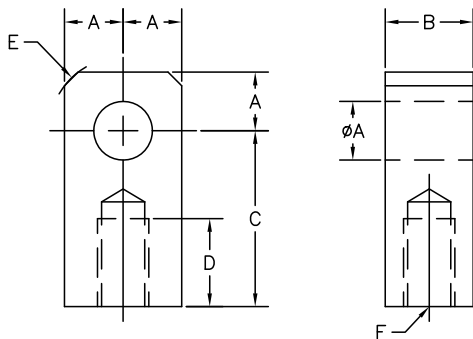

DIM inch (mm)	T2M/X090	T2M/X115
	REI050	RE075
ØA	0.50 (12.7)	0.75 (19.05)
B	0.75 (19.05)	1.25 (31.8)
C	1.50 (38.1)	2.06 (52.3)
D	0.75 (19.05)	1.13 (28.7)
E	0.375 (9.53)	0.88 (22.2)
F	1/2-20	3/4-16

Rod Clevis

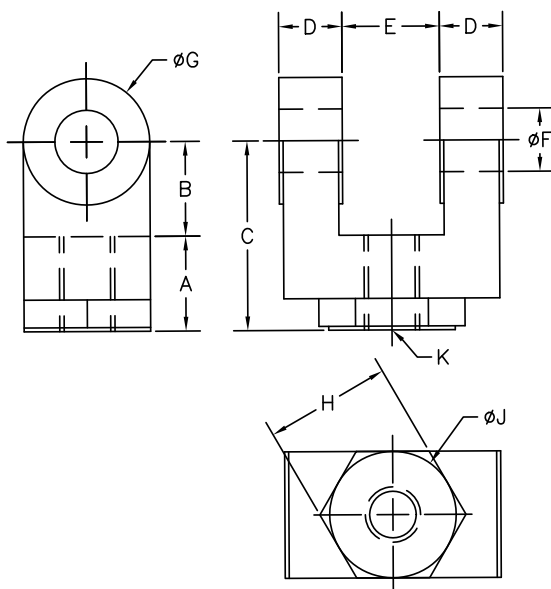

DIM inch (mm)	T2M/X090	T2M/X115
	RCI050	RC075
A	0.750 (19.05)	1.125 (28.58)
B	0.750 (19.05)	1.25 (31.75)
C	1.500 (38.1)	2.375 (60.3)
D	0.500 (12.7)	0.625 (15.88)
E	0.765 (19.43)	1.265 (32.12)
ØF	0.500 (12.7)	0.75 (19.1)
ØG	1.000 (25.4)	1.50 (38.1)
H	1.000 (25.4)	1.25 (31.75)
ØJ	N/A	1.25 (31.75)
K	1/2-20	3/4-16

Linear Actuator Ordering Guide

Tritex II AC T2M/X Linear Actuator Ordering Information

T2M/X = Actuator Type

T2M = Tritex II Linear Actuator, standard mechanical capacity
T2X = Tritex II Linear Actuator, high mechanical capacity

BBB = Actuator Frame Size

090 = 90 mm
115 = 115 mm

CC = Stroke Length

03 = 3 inch (75 mm) (T2M/X090 only)
06 = 6 inch (150 mm)
10 = 10 inch (250 mm)
12 = 12 inch (305 mm)
18 = 18 inch (455 mm)

DD = Lead (linear travel per screw revolution)

01 = 0.1 inch (2.54 mm)
02 = 0.2 inch (5.08 mm)
05 = 0.5 inch (12.7 mm)
08 = 0.75 inch (19.05 mm)
(T2M/X115 only) (5)

E = Connections

G = Standard Straight Threaded Port with Internal terminals, M20 x 1.5
N = NPT Threaded Port via Adapter with Internal Terminals, 1/2" NPT
I = Intercontec Style - Exlar std, M16/M23 Style Connector
X = Custom Connectivity

F = Mounting

B = Front & Rear Flange
C = Rear Clevis

D = Double Side Mount
E = Extended Tie Rod
F = Front Flange
G = Metric Rear Clevis
J = Metric Side Mount
K = Metric Double Side Mount
M = Metric Extended Tie Rod
Q = Metric Side Trunnion
R = Rear Flange
S = Side Mount
T = Side Trunnion
X = Special

G = Rod End

A = Male Metric Thread (1)
B = Female Metric Thread (1)
F = Female US Standard Thread (1)
L = Female Metric Thread 17-4 SS
M = Male US Standard Thread (1)
R = Male Metric Thread 17-4 SS
V = Female US Standard Thread 17-4 SS
W = Male, US Standard Thread 17-4 SS
X = Special (please specify)

HH = Feedback Type

HD = Analog Hall Device
IE = Incremental Encoder, 8192 count resolution
AF = Absolute Feedback

III-II = Motor Stator, All 8 Pole

T2M/X090 Stator Specifications
138-40 = 1 Stack, 230 VAC, 4000 rpm
238-40 = 2 Stack, 230 VAC, 4000 rpm
238-30 = 2 Stack, 230 VAC, 3000 rpm (10)

T2M/XBBB-CCDD-EFG-HH-III-II-JJJ-KKK- (XX..XX - #####)

T2M/X115 Stator Specifications

138-30 = 1 Stack, 230 VAC, 3000 rpm
238-20 = 2 Stack, 230 VAC, 2000 rpm
238-15 = 2 Stack, 230 VAC, 1500 rpm
(N/A with 0.1" lead)

JJJ = Voltage

230 = 115-230 VAC, single phase

KKK = Option Board (only 1 selection allowed)

SIO = Standard I/O Interconnect
IA4 = SIO plus Isolated 4 - 20 mA Analog I/O
EIP = SIO plus Ethernet IP
ABZ = SIO plus encoder output signal, requires IE Feedback option. Includes M12 connector for encoder output signals. (2)
TCP = Modbus TCP

X..XX = Travel and Housing Options (Multiples Possible)

Travel Options

AR = External Anti-rotate
PF = Preloaded Follower (3)
L1/2/3 = External Limit Switches (7)
RB = Rear Brake
XT = Special Travel Options

Housing Options

P5 = IP65 Sealed Housing (T2M only)
HC = Type III Hard Coat Anodized (4)
FG = White Epoxy Coating (4)

Special Motor Options

HW = Manual Drive Hand Wheel (T2X only)
SD = Side Manual Drive
HV = High Vibration Option-EIC (9)
ET = External Linear Transducer

XL = Special Lubrication (6)
XM = Special Motor Option
XH = Special Housing Option
XT = Protective Bellows (N/A with extended tie rod mounting option)
XT = Splined Main Rod (8)

= Part Number Designator for Specials

Optional 5 digit assigned PN to designate unique model numbers

NOTES:

1. Chrome-plated carbon steel. Threads not chrome-plated.
2. Will require external cable for encoder output signals.
3. The dynamic load rating of zero backlash, preloaded screws is 63% of the dynamic load rating of the std non-preloaded screws. The calculated travel life of a preloaded screw will be 25% of the calculated travel life of the same size and lead of a non-preloaded screw.
4. This housing option may indicate the need for special material main rods or mounting.
5. 0.75 lead not available above 12" stroke.
6. To achieve -40 operating temperature, specify -XL in the actuator model mask and define Mobilgrease 28 in order notes. Other special lubricants are also available.
7. Limit switch option requires AR option.
8. This option is not sealed and is not suitable for any environment in which contaminants come in contact with actuator and may enter the actuator.
9. EIC 60068-2-64 2.5g, 50-500 Hz. See page 4 for details.
10. N/A with 0.1" lead

Rotary Motor and Gearmotor Ordering Guide

Tritex II AC R2M Motor or R2G Gearmotor Ordering Information

R2M/G = Motor Type

R2M = Tritex II AC Rotary Motor
R2G = Tritex II AC Rotary Gearmotor

AAA = Frame Size

090 = 90 mm
115 = 115 mm

BBB = Gear Ratio

Blank = R2M

Single Reduction Ratios

004 = 4:1
005 = 5:1
010 = 10:1

Double Reduction Ratios

016 = 16:1 020 = 20:1
025 = 25:1 040 = 40:1
050 = 50:1 100 = 100:1

C = Shaft Type

K = Keyed
R = Smooth/Round
X = Special Shaft

D = Connections

G = Standard Straight Threaded Port with Internal Terminals, M20 x 1.5
N = NPT Threaded Port via Adapter with Internal Terminals, 1/2" NPT
I = Intercontec style - Exlar Standard, M16/M23 Style Connector
X = Custom Connectivity

E = Housing Options

G = Exlar Standard
H = Type III Hard Coat Anodized
F = Smooth White Epoxy Coating
E = Electroless Nickel Plating
X = Special or Custom

F = Brake Option

S = No Brake, Standard
B = Electric Brake, 24 VDC

GG = Feedback Type

HD = Analog Hall Device
IE = Incremental Encoder, 8192 Count Resolution

R2M/GAAA-BBB-CDEF-GG-HHH-HH-III-JJJ (XX...XX) -

AF = Absolute Feedback

HHH-HH = Motor Stators

R2M/G090 Stator Specifications
238-40 = 2 Stack, 230 VAC, 4000 rpm
238-30 = 2 Stack, 230 VAC, 3000 rpm
338-20 = 3 Stack, 230 VAC, 2000 rpm

R2M/G115 Stator Specifications

138-30 = 1 Stack, 230 VAC, 3000 rpm
238-20 = 2 Stack, 230 VAC, 2000 rpm
238-15 = 2 Stack, 230 VAC, 1500 rpm

III = Voltage

230 = 115-230 VAC, Single Phase

JJJ = Option Board

SIO = Standard I/O Interconnect
IA4 = SIO plus Isolated 4-20 mA Analog I/O
EIP = SIO plus Ethernet IP
ABZ = SIO plus encoder output signal, requires IE Feedback option. Includes M12 connector for encoder output signals (2)
TCP = SIO plus Modbus TCP

XX = Special Options (multiples possible)

HW = Manual Drive Handwheel with Limit Switch
SD = Side Manual Drive
HV = High Vibration Option-IEC (1)
XH = Special Housing Options
XM = Special Motor Options
XL = Special Lubrication (3)

= Part Number Designator for Specials

Optional 5 digit assigned PN to designate unique model no.

NOTES:

1. EIC 60068-2-64 2.5g, 50-500 Hz. See page 4 for details.
2. Will require external cable for encoder output signals.
3. To achieve -40 operating temperature, specify -XL in the actuator model mask and define Mobilgrease 28 in order notes. Other special lubricants are also available.

Cables/Accessories Ordering Guide

Tritex II AC Series Cable & Accessories	Part No.
“G” Connection Accessories	
Nickel plated cable gland- M20 x 1.5 - CE shielding- 2 required	GLD-T2M20 x 1.5
Power cable prepared on one end for use with GLD-T2M20 x 1.5 xxx = Length in ft, Standard lengths 015, 025, 050, 075, 100	CBL-T2IPC-RAW-xxx
I/O cable prepared on one end for use with GLD-T2M20 x 1.5 xxx = Length in ft, Standard lengths 015, 025, 050, 075, 100	CBL-T2I0C-RAW-xxx
“N” Connection Accessories	
M20 x 1.5 to 1/2" NPT threaded hole adapter for use with conduit	ADAPT-M20-NPT1/2
“I” Connection	
Power cable with M23 6 pin xxx = Length in feet, std lengths 015, 025, 050, 075, 100	CBL-T2IPC-SMI-xxx
I/O cable with M16 19 pin xxx = Length in feet, std lengths 015, 025, 050, 075, 100	CBL-T2I0C-SMI-xxx
Communications Accessories - Tritex uses a 4 pin M8 RS485 communications connector	
Recommended PC to Tritex communications cable-USB/RS485 to M8 connector - xxx = Length in feet, 006 or 015 only	CBL-T2USB485-M8-xxx
Multi-Drop RS485 Accessories	
RS485 splitter - M8 Pin plug to double M8 Socket receptacle	TT485SP
Multidrop Communications Cable M8 to M8 for use with TT485SP/RS485 splitter - xxx = Length in feet, 006 or 015 only	CBL-TTDAS-xxx
Multi-Purpose Communications Accessories for long runs, requires terminal block interconnections	
USB to RS485 convertor/cable - USB to RS485 flying leads - xxx = Length in feet, 006 or 015 only	CBL-T2USB485-xxx
Communications cable M8 to flying leads cable xxx = Length in feet, Standard lengths 015, 025, 050, 075, 100	CBL-TTCOM-xxx
Option Board Cables	
EIP and TCP option Ethernet cable - M12 to RJ45 cable xxx = Length in feet, standard lengths 015, 025, 050, 075, 100	CBL-T2ETH-R45-xxx
ABZ option cable - M12 to flying leads 8 wire encoder output cable xxx = Length in feet, standard lengths 015, 025, 050, 075, 100	CBL-T2ENC-xxx
Electrical Accessories	
Dynamic Braking Resistor - 100W470hm	T2BR1
Replacement -AF Battery - used for absolute feedback option	T2BAT1
Replacement Normally Closed External Limit Switch (Turck Part number BIM-UNT-RP6X)	43404
Replacement Normally Open External Limit Switch (Turck Part number BIM-UNT-AP6X)	43403
Mechanical Accessories	
Clevis Pin for T2M/X090 male “M” rod end 1/2-20 thread	CP050
Clevis Pin for T2M/X115 male “M” rod end 3/4-16 thread	CP075
Spherical Rod Eye for T2M/X090 male “M” rod end 1/2-20 thread	SRM050
Spherical Rod Eye for T2M/X115 male “M” rod end 3/4-16 thread	SRM075
Rod Eye for T2M/X090 male “M” rod end 1/2-20 thread	REI050
Rod Eye for T2M/X115 male “M” rod end 3/4-16 thread	RE075
Rod Clevis for T2M/X090 male “M” rod end 1/2-20 thread	RCI050
Rod Clevis for T2M/X115 male “M” rod end 3/4-16 thread	RC075
Jam Nut for T2M/X090 male rod end, 1/2 - 20	JAM1/2-20-SS
Jam Nut for T2M/X115 male rod end, 3/4-16	JAM3/4-16-SS

Options/Accessories



CBL-T2USB485-M8-xxx

Our recommended communications cable. No special drivers or setup required for use with MS Windows™.



CBL-T2USB485-xxx

Use for terminal connections with CBL-TTCOM for long cable runs. No special drivers or setup required for use with MS Windows™.



CBL-TTCOM-xxx

Use with CBL-T2USB485-xxx for long cable runs.



CBL-TTDAS-xxx

For use with TT485SP for multi-drop applications.

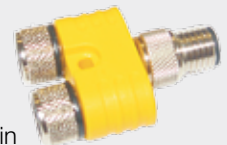

TT485SP

RS485 communications splitter. Use to daisy-chain multiple Tritex actuators.



Visit tritex2.com

For more
information



Headquartered at our manufacturing and motion control research center in suburban Minneapolis, MN, Exlar serves a global customer base with an extensive standard product line and complete engineering support for custom applications.

Exlar provides sales and support world-wide. To find your local representative, visit our website at www.exlar.com or call our headquarters at 952-500-6200.

Request a free copy of our literature by calling **952-500-6200** or download the pdf at **www.exlar.com**. In addition to the 2011 Product Catalog, brochures are available on Exlar's component roller screws and Tritex or Tritex II Actuators with Embedded Electronics. Process control and defense industry brochures are also available.

Exlar Corporation
18400 West 77th Street
Chanhassen, MN 55317

TEL: 952.500.6200
Toll FREE in US and Canada: 855.620.6200
General FAX: 952.368.4877
Order Only FAX: 952.368.4359

www.exlar.com

EXLAR